



# Owner's Manual

*For your safety and comfort, read carefully and keep in the vehicle.*

## RAV4



©2024 TOYOTA MOTOR CORPORATION

All rights reserved. This material may not be reproduced or copied, in whole or in part, without the written permission of Toyota Motor Corporation.

## Pictorial index

Search by illustration

### For safety and security

Make sure to read through them  
(Main topics: Child seat, theft deterrent system)

1

### Vehicle status information and indicators

Reading driving-related information  
(Main topics: Meters, multi-information display)

2

### Before driving

Opening and closing the doors and windows, adjustment before driving  
(Main topics: Keys, doors, seats, power windows)

3

### Driving

Operations and advice which are necessary for driving  
(Main topics: Starting hybrid system, refueling)

4

### Interior features

Usage of the interior features  
(Main topics: Air conditioner, storage features)

5

### Maintenance and care

Caring for your vehicle and maintenance procedures  
(Main topics: Interior and exterior, light bulbs)

6

### When trouble arises

What to do in case of malfunction and emergency  
(Main topics: 12-volt battery discharge, flat tire)

7

### Vehicle specifications

Vehicle specifications, customizable features  
(Main topics: Fuel, oil, tire inflation pressure)

8

## Index

Search by symptom

Search alphabetically

For your information .....	<b>6</b>	Multi-information display (with 7-inch display).....	<b>88</b>
Reading this manual.....	<b>11</b>	Multi-information display (with 12.3-inch display) .....	<b>98</b>
How to search .....	<b>12</b>	Energy monitor/consumption screen.....	<b>107</b>
Pictorial index .....	<b>14</b>		

## **1 For safety and security**

<b>1-1. For safe use</b>	
Before driving.....	<b>26</b>
For safe driving.....	<b>27</b>
Seat belts.....	<b>29</b>
SRS airbags.....	<b>32</b>
Exhaust gas precautions .....	<b>39</b>
<b>1-2. Child safety</b>	
Riding with children.....	<b>41</b>
Child restraint systems .....	<b>42</b>
<b>1-3. Emergency assistance</b>	
Toyota Connected Services..	<b>56</b>
<b>1-4. Hybrid system</b>	
Hybrid system features .....	<b>60</b>
Hybrid system precautions ...	<b>63</b>
<b>1-5. Theft deterrent system</b>	
Immobilizer system.....	<b>68</b>
Double locking system.....	<b>69</b>

## **2 Vehicle status information and indicators**

<b>2-1. Instrument cluster</b>	
Warning lights and indicators	<b>72</b>
Gauges and meters (with 7-inch display) .....	<b>78</b>
Gauges and meters (with 12.3-inch multi-information display) .....	<b>83</b>

## **3 Before driving**

<b>3-1. Key information</b>	
Keys.....	<b>112</b>
<b>3-2. Opening, closing and locking the doors</b>	
Side doors.....	<b>115</b>
Back door.....	<b>120</b>
Smart entry & start system .	<b>129</b>
<b>3-3. Adjusting the seats</b>	
Front seats.....	<b>134</b>
Rear seats .....	<b>135</b>
Driving position memory .....	<b>137</b>
Head restraints .....	<b>140</b>
<b>3-4. Adjusting the steering wheel and mirrors</b>	
Steering wheel.....	<b>142</b>
Inside rear view mirror .....	<b>143</b>
Digital Rear-view Mirror .....	<b>144</b>
Outside rear view mirrors....	<b>153</b>
<b>3-5. Opening, closing the windows and moon roof</b>	
Power windows.....	<b>155</b>
Moon roof.....	<b>158</b>

## **4 Driving**

<b>4-1. Before driving</b>	
Driving the vehicle .....	<b>162</b>

Cargo and luggage .....168

Trailer towing (except Australia and New Zealand) .....169

Trailer towing (for Australia and New Zealand) .....170

**4-2. Driving procedures**

Power (ignition) switch .....177

EV drive mode .....181

Hybrid transmission .....183

Turn signal lever .....186

Parking brake.....187

Brake Hold .....191

**4-3. Operating the lights and wipers**

Headlight switch.....193

AHB (Automatic High Beam) .....195

Fog light switch .....198

Windshield wipers and washer .....199

Rear window wiper and washer .....201

**4-4. Refueling**

Opening the fuel tank cap...203

**4-5. Using the driving support systems**

Toyota Safety Sense .....205

PCS (Pre-Collision System)210

LTA (Lane Tracing Assist) ..220

RSA (Road Sign Assist).....231

Dynamic radar cruise control with full-speed range .....234

Cruise control.....246

BSM (Blind Spot Monitor) ...249

Toyota parking assist-sensor .....253

RCTA (Rear Cross Traffic Alert) function .....263

PKSB (Parking Support Brake) .....268

Parking Support Brake function (static objects) .....273

Parking Support Brake function (rear-crossing vehicles) ....276

Driving mode select switch .278

Trail Mode (AWD vehicles) .280

Driving assist systems .....281

**4-6. Driving tips**

Hybrid Electric Vehicle driving tips .....288

Winter driving tips .....290

Utility vehicle precautions ...293

**5 Interior features**

**5-1. Using the air conditioning system and defogger**

Automatic air conditioning system.....298

Seat heaters/Seat ventilators .....304

**5-2. Using the interior lights**

Interior lights list.....306

**5-3. Using the storage features**

List of storage features .....308

Luggage compartment features .....312

**5-4. Using the other interior features**

Other interior features.....317



## 6 Maintenance and care

### 6-1. Maintenance and care

Cleaning and protecting the vehicle exterior ..... **328**

Cleaning and protecting the vehicle interior ..... **332**

### 6-2. Maintenance

Maintenance requirements ..... **335**

### 6-3. Do-it-yourself maintenance

Do-it-yourself service precautions ..... **337**

Hood ..... **339**

Positioning a floor jack ..... **340**

Engine compartment ..... **342**

12-volt battery ..... **347**

Tires ..... **349**

Tire inflation pressure ..... **351**

Wheels ..... **352**

Air conditioning filter ..... **353**

Cleaning the hybrid battery (traction battery) air intake vent ..... **355**

Wiper insert replacement ..... **359**

Electronic key battery ..... **363**

Checking and replacing fuses ..... **365**

Light bulbs ..... **367**

## 7 When trouble arises

### 7-1. Essential information

Emergency flashers ..... **376**

If your vehicle has to be stopped in an emergency ..... **376**

If the vehicle is submerged or water on the road is rising ..... **377**

### 7-2. Steps to take in an emergency

If your vehicle needs to be towed ..... **379**

If you think something is wrong ..... **383**

If a warning light turns on or a warning buzzer sounds ..... **385**

If a warning message is displayed ..... **392**

If you have a flat tire ..... **396**

If the hybrid system will not start ..... **404**

If you lose your keys ..... **405**

If the fuel filler door cannot be opened ..... **406**

If the electronic key does not operate properly ..... **406**

If the 12-volt battery is discharged ..... **408**

If your vehicle overheats ..... **413**

If the vehicle becomes stuck ..... **416**

## 8 Vehicle specifications

### 8-1. Specifications

Maintenance data (fuel, oil level, etc.) ..... **420**

Fuel information ..... **428**

### 8-2. Customization

Customizable features ..... **429**

### 8-3. Initialization

Items to initialize ..... **442**

**Index**

What to do if... (Troubleshooting) .....	444
Alphabetical Index .....	446

1

2

3

4

5

6

7

8

## For your information

### Main Owner's Manual

Please note that this manual applies to all models and explains all equipment, including options. Therefore, you may find some explanations for equipment not installed on your vehicle.

All specifications provided in this manual are current at the time of printing. However, because of the Toyota policy of continual product improvement, we reserve the right to make changes at any time without notice.

Depending on specifications, the vehicle shown in the illustrations may differ from your vehicle in terms of equipment.

### Accessories, spare parts and modification of your Toyota

A wide variety of non-genuine spare parts and accessories for Toyota vehicles are currently available in the market. Using these spare parts and accessories which are not genuine Toyota products may adversely affect the safety of your vehicle, even though these parts may be approved by certain authorities in your country. Toyota Motor Corporation therefore cannot accept any liability or guarantee spare parts and accessories which

are not genuine Toyota products, nor for replacement or installation involving such parts.

This vehicle should not be modified with non-genuine Toyota products. Modification with non-genuine Toyota products could affect its performance, safety or durability, and may even violate governmental regulations. In addition, damage or performance problems resulting from the modification may not be covered under warranty.

Also, remodeling like this will have an effect on advanced safety equipment such as Toyota Safety Sense and there is a danger that it will not work properly or the danger that it may work in situations where it should not be working.

### Cyber Attack Risk

Installing electronic devices and radios increases the risk of cyber attacks through the installed parts, which may lead to unexpected accidents and leakage of personal information. Toyota does not make any guarantees for problems caused by installing non-genuine Toyota products.

### Installation of an RF-transmitter system

The installation of an RF-transmitter system in your vehicle could affect electronic systems such as:



- Hybrid system
- Multiport fuel injection system/sequential multiport fuel injection system
- Toyota Safety Sense
- Cruise control system
- Anti-lock brake system
- SRS airbag system
- Seat belt pretensioner system

Be sure to check with your Toyota dealer for precautionary measures or special instructions regarding installation of an RF-transmitter system.

Further information regarding frequency bands, power levels, antenna positions and installation provisions for the installation of RF-transmitters, is available on request at your Toyota dealer.

High voltage parts and cables on the Hybrid Electric Vehicles emit approximately the same amount of electromagnetic waves as the conventional gasoline powered vehicles or home electronic appliances despite of their electromagnetic shielding.

Unwanted noise may occur in the reception of the radio frequency transmitter (RF-transmitter).

## Vehicle data recording

The vehicle is equipped with sophisticated computers that will record certain data, such as:

- Engine speed/Electric motor speed (traction motor speed)
- Accelerator status
- Brake status
- Vehicle speed
- Operation status of the driving assist systems
- Images from the cameras  
Your vehicle is equipped with cameras. Contact your Toyota dealer for the location of recording cameras.

The recorded data varies according to the vehicle grade level and options with which it is equipped.

These computers do not record conversations or sounds, and only record images outside of the vehicle in certain situations.

### ● Data usage

Toyota may use the data recorded in this computer to diagnose malfunctions, conduct research and development, and improve quality.

Toyota will not disclose the recorded data to a third party except:

- With the consent of the vehicle owner or with the consent of the lessee if the vehicle is leased
- In response to an official request by the police, a court of law or a government agency
- For use by Toyota in a lawsuit
- For research purposes where the data is not tied to a specific vehicle or vehicle owner
- Recorded image information can be erased by your Toyota dealer.

The image recording function can be

disabled. However, if the function is disabled, data from when the system operates will not be available.

### Usage of data collected through Toyota Connected Services

If your Toyota has Toyota Connected Services and if you have subscribed to those services, please refer to the Toyota Connected Services usage contract for information on data collected and its usage.

For more information, visit <https://www.toyota.com.au/privacy>

### Event data recorder

This vehicle is equipped with an event data recorder (EDR). The main purpose of an EDR is to record, in certain crash or near crash-like situations, such as an airbag deployment or hitting a road obstacle, data that will assist in understanding how a vehicle's systems performed. The EDR is designed to record data related to vehicle dynamics and safety systems for a short period of time, typically 30 seconds or less. However, data may not be recorded depending on the severity and type of a crash.

The EDR in this vehicle is designed to record such data as:

- How various systems in your

vehicle were operating;

- How far (if at all) the driver was depressing the accelerator and/or brake pedal; and,
- How fast the vehicle was traveling.

These data can help provide a better understanding of the circumstances in which crashes and injuries occur.

NOTE: EDR data are recorded by your vehicle only if a non-trivial crash situation occurs; no data are recorded by the EDR under normal driving conditions and no personal data (e.g., name, gender, age, and crash location) are recorded. However, other parties, such as law enforcement, could combine the EDR data with the type of personally identifying data routinely acquired during a crash investigation.

To read data recorded by an EDR, special equipment is required, and access to the vehicle or the EDR is needed. In addition to the vehicle manufacturer, other parties, such as law enforcement, that have the special equipment, can read the information if they have access to the vehicle or the EDR.

- Disclosure of the EDR data

Toyota will not disclose the data recorded in an EDR to a third party except when:

- An agreement from the vehicle's owner (or the lessee for a leased

vehicle) is obtained

- In response to an official request by the police, a court of law or a government agency
- For use by Toyota in a lawsuit

However, if necessary, Toyota may:

- Use the data for research on vehicle safety performance
- Disclose the data to a third party for research purposes without disclosing information about the specific vehicle or vehicle owner

## Scrapping of your Toyota

The SRS airbag and seat belt pretensioner devices in your Toyota contain explosive chemicals. If the vehicle is scrapped with the airbags and seat belt pretensioners left as they are, this may cause an accident such as fire. Be sure to have the systems of the SRS airbag and seat belt pretensioner removed and disposed of by a qualified service shop or by your Toyota dealer before you scrap your vehicle.



### WARNING

#### ■ General precautions while driving

**Driving under the influence:** Never drive your vehicle when under the influence of alcohol or drugs that have impaired your ability to operate your vehicle. Alcohol and certain drugs delay reaction time, impair judgment and reduce coordination, which could lead to an accident that could result in death or serious injury.

**Defensive driving:** Always drive defensively. Anticipate mistakes that other drivers or pedestrians might make and be ready to avoid accidents.

**Driver distraction:** Always give your full attention to driving. Anything that distracts the driver, such as adjusting controls, talking on a cellular phone or reading can result in a collision with resulting death or serious injury to you, your occupants or others.

#### ■ General precaution regarding children's safety

Never leave children unattended in the vehicle, and never allow children to have or use the key.

Children may be able to start the vehicle or shift the vehicle into neutral. There is also a danger that children may injure themselves by playing with the side windows, the moon roof or the panoramic moon roof, or other features of the vehicle. In addition, heat build-up or extremely cold temperatures inside the vehicle can be fatal to children.

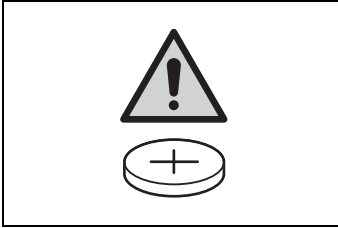
**WARNING****■ General precaution regarding a coin battery and button battery**

This product contains a coin battery or button battery.



Observe the following precautions. Failure to do so may result in death or serious injury.

- Keep away new and removed batteries from children.
- Do not swallow the battery. Doing so may cause chemical burns.
- If a battery is swallowed, it may cause severe chemical burns in as little as 2 hours and may result in death or serious injury.
- If you accidentally swallow a battery or put a battery into a part of your body, get emergency medical attention immediately.

## Reading this manual



**Explains symbols used in this manual**

## Symbols in this manual

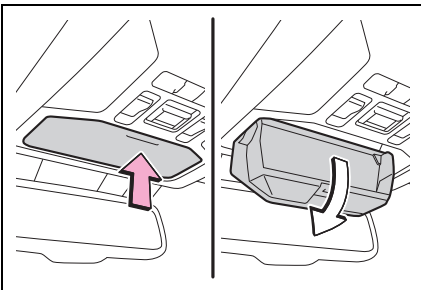

Symbols	Meanings
	<b>WARNING:</b> Explains something that, if not obeyed, could cause death or serious injury to people.
	<b>NOTICE:</b> Explains something that, if not obeyed, could cause damage to or a malfunction in the vehicle or its equipment.
1 2 3...	Indicates operating or working procedures. Follow the steps in numerical order.

## Symbols in illustrations

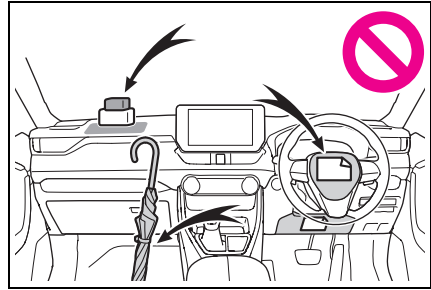

Symbols	Meanings
	Indicates the action (pushing, turning, etc.) used to operate switches and other devices.
	Indicates the outcome of an operation (e.g. a lid opens).



Symbols	Meanings
	Indicates the component or position being explained.
	Means <b>Do not</b> , <b>Do not do this</b> , or <b>Do not let this happen</b> .

## How to search

### ■ Searching by name

- Alphabetical index: →P.446

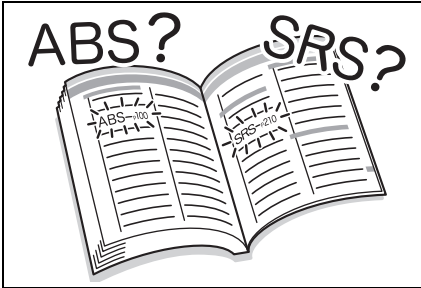

### ■ Searching by installation position

- Pictorial index: →P.14

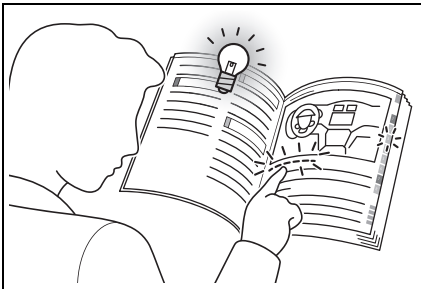

### ■ Searching by symptom or sound

- What to do if... (Troubleshooting): →P.444

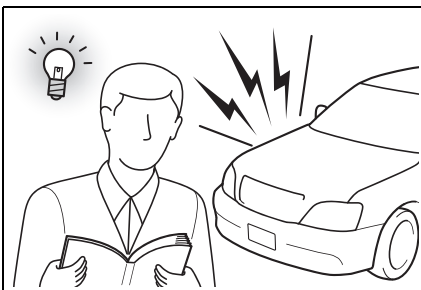

### ■ Searching by title

- Table of contents: →P.2

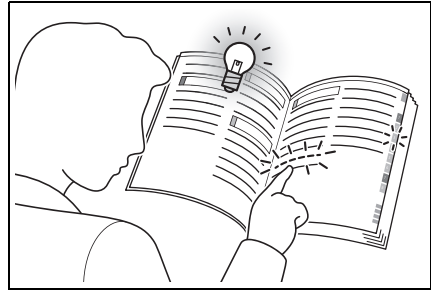







	Precautions against winter season .....	P.290
	Precautions against car wash .....	P.329
	Replacing the wiper insert.....	P.359
<b>E</b>	<b>Fuel filler door .....</b>	<b>P.203</b>
	Refueling method.....	P.203
	Fuel type/fuel tank capacity .....	P.421
<b>F</b>	<b>Tires .....</b>	<b>P.349</b>
	Tire size/inflation pressure .....	P.426
	Winter tires/tire chain .....	P.290
	Checking/rotation .....	P.349
	Coping with flat tires.....	P.396
<b>G</b>	<b>Hood.....</b>	<b>P.339</b>
	Opening .....	P.339
	Engine oil .....	P.422
	Coping with overheat .....	P.413
	Warning messages .....	P.392

### Light bulbs of the exterior lights for driving

(Replacing method: P.367, Watts: P.427)

<b>H</b>	<b>Headlights/front position lights/daytime running lights .....</b>	<b>P.193</b>
<b>I</b>	<b>Turn signal lights .....</b>	<b>P.186</b>
<b>J</b>	<b>Fog lights.....</b>	<b>P.198</b>
<b>K</b>	<b>Stop lights/tail lights/turn signal lights.....</b>	<b>P.186, 193</b>
<b>L</b>	<b>License plate lights.....</b>	<b>P.193</b>
<b>M</b>	<b>Tail lights .....</b>	<b>P.193</b>
	<b>Back-up lights</b>	
	Shifting the shift lever to R.....	P.183

\*: If equipped

## ■ Instrument panel

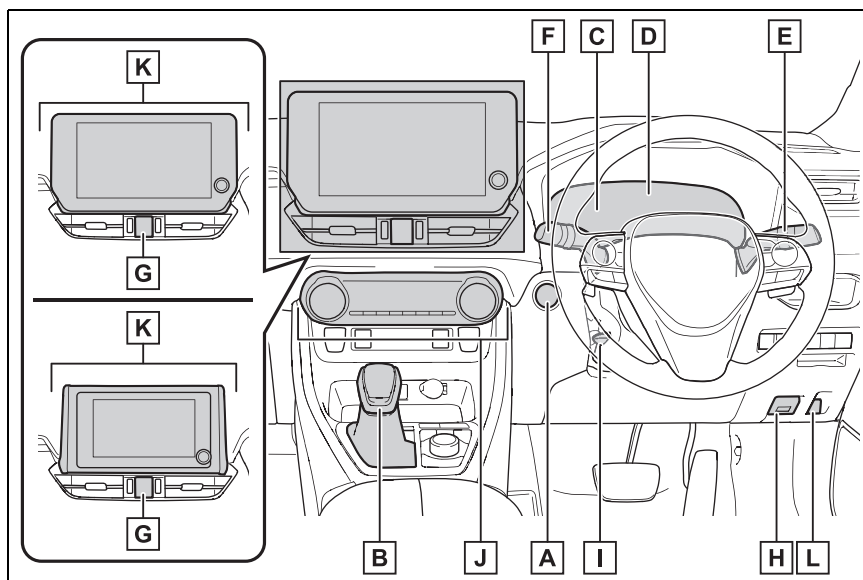

- A Power switch** ..... **P.177**  
 Starting the hybrid system/changing the modes ..... P.177, 179  
 Emergency stop of the hybrid system ..... P.376  
 When the hybrid system will not start ..... P.404  
 Warning messages ..... P.392
- B Shift lever** ..... **P.183**  
 Changing the shift position ..... P.184  
 Precautions against towing ..... P.379  
 When the shift lever does not move ..... P.184
- C Meters** ..... **P.78, 83**  
 Reading the meters/adjusting the instrument cluster light ..... P.82, 104  
 Warning lights/indicator lights ..... P.72  
 When the warning lights come on ..... P.385
- D Multi-information display** ..... **P.88, 98**  
 Display ..... P.88, 98

	Energy monitor.....	P.107
	When the warning messages are displayed .....	P.392
<b>E</b>	<b>Turn signal lever .....</b>	<b>P.186</b>
	<b>Headlight switch .....</b>	<b>P.193</b>
	Headlights/front position lights/tail lights/ license plate lights/daytime running lights.....	P.193
	Fog lights .....	P.198
<b>F</b>	<b>Windshield wiper and washer switch .....</b>	<b>P.199</b>
	<b>Rear window wiper and washer switch .....</b>	<b>P.201</b>
	Usage.....	P.199, 201
	Adding washer fluid.....	P.346
<b>G</b>	<b>Emergency flasher switch.....</b>	<b>P.376</b>
<b>H</b>	<b>Hood lock release lever .....</b>	<b>P.339</b>
<b>I</b>	<b>Tilt and telescopic steering control lever .....</b>	<b>P.142</b>
	Adjustment.....	P.142
<b>J</b>	<b>Air conditioning system .....</b>	<b>P.298</b>
	Usage.....	P.298
	Rear window defogger .....	P.300
<b>K</b>	<b>Audio system*</b>	
<b>L</b>	<b>Fuel filler door opener switch .....</b>	<b>P.204</b>

\*: Refer to "Multimedia Owner's Manual".

## ■ Switches

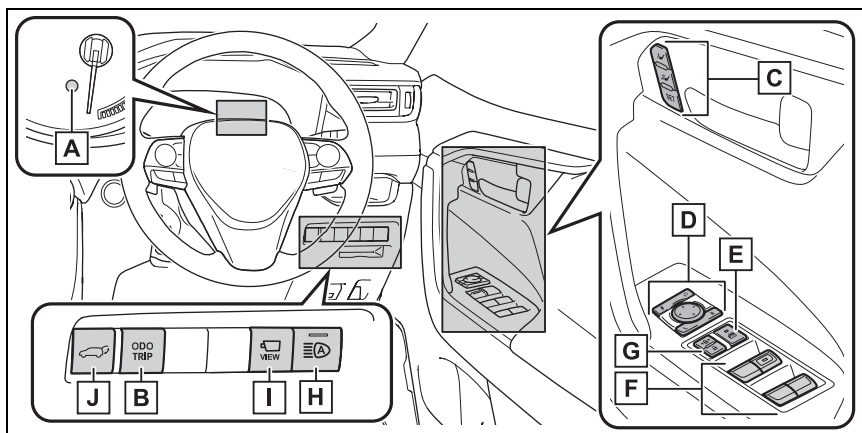

- A** “ODO TRIP” switch (vehicles with 7-inch multi-information display) ..... P.82
- B** “ODO TRIP” switch (vehicles with 12.3-inch multi-information display)..... P.88
- C** Driving position memory switches\*<sup>1</sup> ..... P.137
- D** Outside rear view mirror switches ..... P.153
- E** Window lock switch..... P.157
- F** Power window switches..... P.155
- G** Door lock switches ..... P.118
- H** Automatic High Beam switch\*<sup>1</sup> ..... P.195
- I** Camera switch\*<sup>1, 2</sup>
- J** Power back door switch\*<sup>1</sup> ..... P.123

\*<sup>1</sup>: If equipped

\*<sup>2</sup>: Refer to “Multimedia Owner’s Manual”.

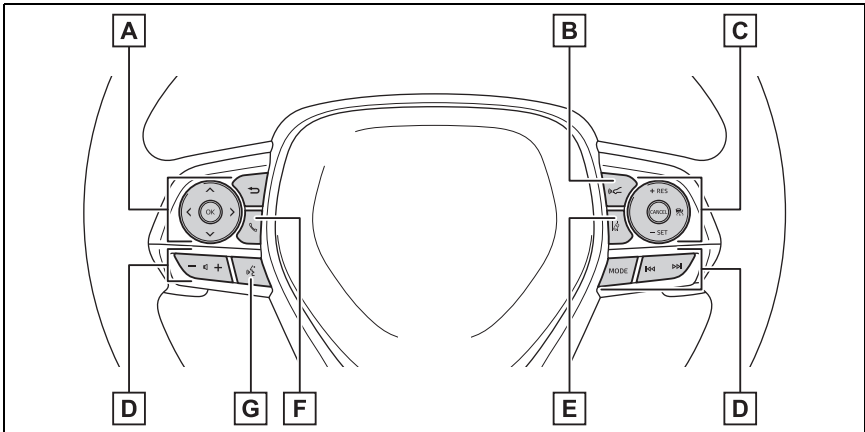

- A** Meter control switches ..... P.89
- B** Vehicle-to-vehicle distance switch<sup>\*1</sup> ..... P.238
- C** Cruise control switches
  - Dynamic radar cruise control with full-speed range<sup>\*1</sup> ..... P.234
  - Cruise control<sup>\*1</sup> ..... P.246
- D** Audio remote control switches<sup>\*2</sup>
- E** LTA (Lane Tracing Assist) switch<sup>\*1</sup> ..... P.220
- F** Phone switch<sup>\*2</sup>
- G** Talk switch<sup>\*2</sup>

<sup>\*1</sup>: If equipped

<sup>\*2</sup>: Refer to "Multimedia Owner's Manual".

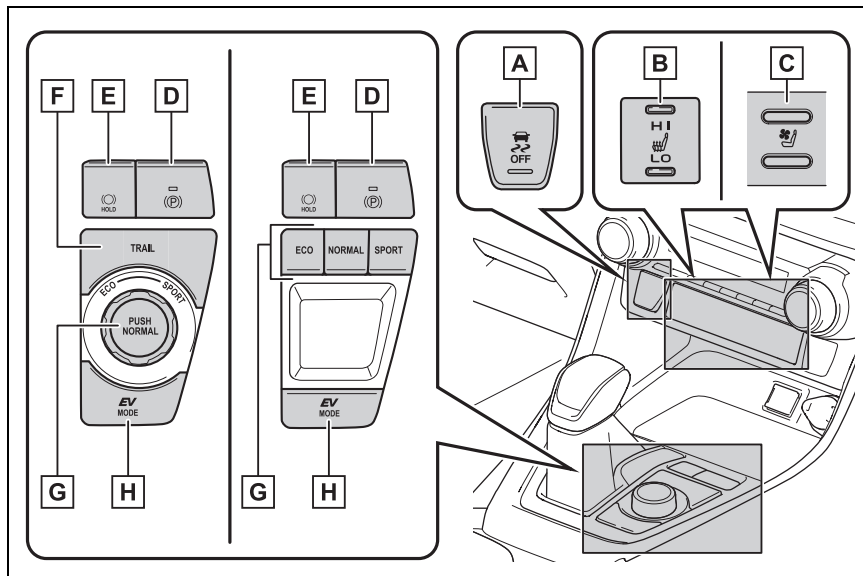

- A** VSC OFF switch ..... P.282
- B** Front seat heater switches\* ..... P.304
- C** Front seat heater and seat ventilator switches\* ..... P.304
- D** Parking brake switch ..... P.187  
 Applying/releasing..... P.187  
 Precautions against winter season ..... P.291  
 Warning buzzer/message ..... P.189, 190, 385
- E** Brake hold switch ..... P.191
- F** Trail Mode switch\* ..... P.280
- G** Driving mode select switch..... P.278
- H** EV drive mode switch ..... P.181

\*: If equipped

## Interior

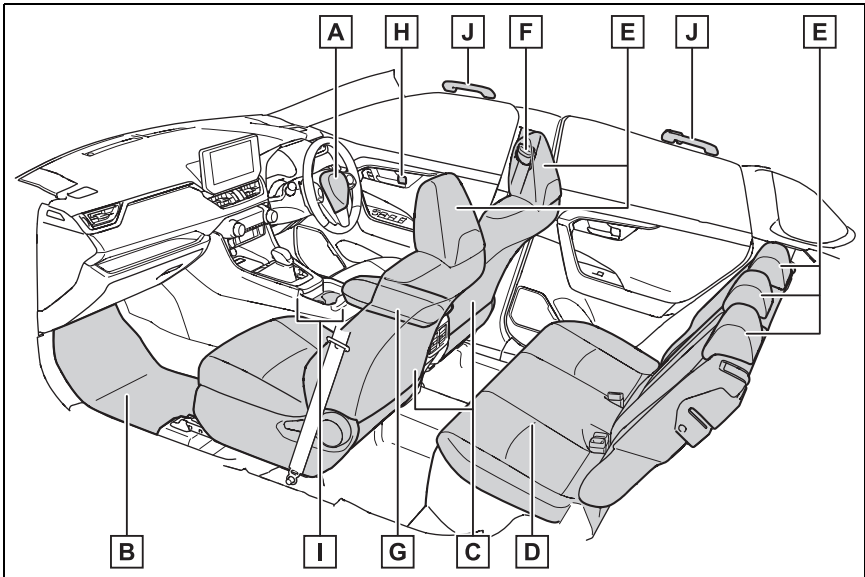

- A** SRS airbags ..... P.32
- B** Floor mats ..... P.26
- C** Front seats ..... P.134
- D** Rear seats ..... P.135
- E** Head restraints ..... P.140
- F** Seat belts ..... P.29
- G** Console box ..... P.309
- H** Inside lock buttons ..... P.118
- I** Cup holders ..... P.309
- J** Assist grips ..... P.325

## ■ Ceiling

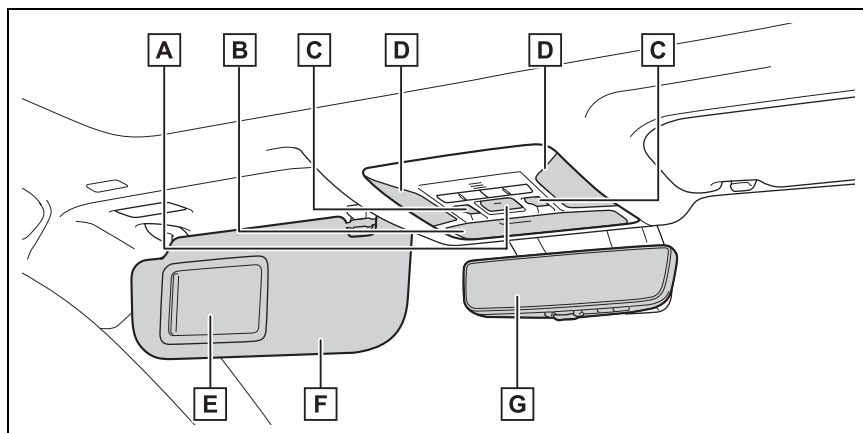

- |          |  |              |
|----------|--|--------------|
| <b>A</b> | <b>“SOS” button<sup>*1</sup></b> .....             | <b>P.56</b>  |
| <b>B</b> | <b>Auxiliary box</b> .....                         | <b>P.310</b> |
| <b>C</b> | <b>Moon roof switches<sup>*1</sup></b> .....       | <b>P.158</b> |
| <b>D</b> | <b>Interior lights<sup>*2</sup></b> .....          | <b>P.307</b> |
|          | <b>Personal lights</b> .....                       | <b>P.307</b> |
| <b>E</b> | <b>Vanity mirrors</b> .....                        | <b>P.317</b> |
| <b>F</b> | <b>Sun visors<sup>*3</sup></b> .....               | <b>P.317</b> |
| <b>G</b> | <b>Inside rear view mirror<sup>*1</sup></b> .....  | <b>P.143</b> |
|          | <b>Digital Rear-view Mirror<sup>*1</sup></b> ..... | <b>P.144</b> |

<sup>\*1</sup>: If equipped

<sup>\*2</sup>: The illustration shows the front, but they are also equipped in the rear.

<sup>\*3</sup>: NEVER use a rearward facing child restraint on a seat protected by an ACTIVE AIRBAG in front of it, DEATH or SERIOUS INJURY to the CHILD can occur.  
(→P.44)







# For safety and security

## 1

- 1-1. For safe use**
  - Before driving ..... **26**
  - For safe driving ..... **27**
  - Seat belts ..... **29**
  - SRS airbags ..... **32**
  - Exhaust gas precautions .... **39**
- 1-2. Child safety**
  - Riding with children ..... **41**
  - Child restraint systems ..... **42**
- 1-3. Emergency assistance**
  - Toyota Connected Services **56**
- 1-4. Hybrid system**
  - Hybrid system features ..... **60**
  - Hybrid system precautions . **63**
- 1-5. Theft deterrent system**
  - Immobilizer system ..... **68**
  - Double locking system ..... **69**

## Before driving

Observe the following before starting off in the vehicle to ensure safety of driving.

### Installing floor mats

Use only floor mats designed specifically for vehicles of the same model and model year as your vehicle. Fix them securely in place onto the carpet.

- 1 Insert the retaining hooks (clips) into the floor mat eyelets.

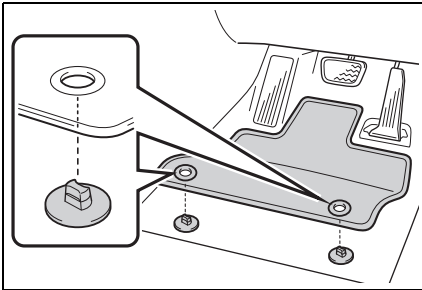

- 2 Turn the upper knob of each retaining hook (clip) to secure the floor mats in place.

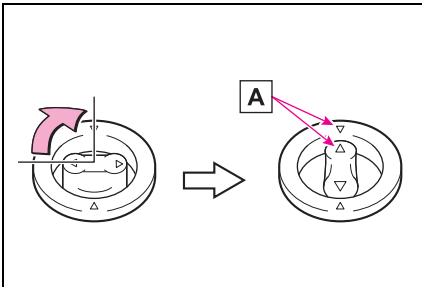

Always align the  $\triangle$  marks **A**.

The shape of the retaining hooks (clips) may differ from that shown in the illus-

tration.

### **!** WARNING

Observe the following precautions. Failure to do so may cause the driver's floor mat to slip, possibly interfering with the pedals while driving. An unexpectedly high speed may result or it may become difficult to stop the vehicle. This could lead to an accident, resulting in death or serious injury.

#### ■ When installing the driver's floor mat

- Do not use floor mats designed for other models or different model year vehicles, even if they are Toyota Genuine floor mats.
- Only use floor mats designed for the driver's seat.
- Always install the floor mat securely using the retaining hooks (clips) provided.
- Do not use two or more floor mats on top of each other.
- Do not place the floor mat bottom-side up or upside-down.

#### ■ Before driving

- Check that the floor mat is securely fixed in the correct place with all the provided retaining hooks (clips). Be especially careful to perform this check after cleaning the floor.

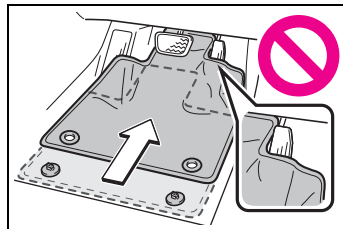

**WARNING**

- With the hybrid system stopped and the shift lever in P, fully depress each pedal to the floor to make sure it does not interfere with the floor mat.

**For safe driving**

**For safe driving, adjust the seat and mirror to an appropriate position before driving.**

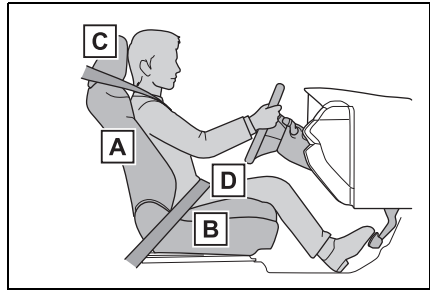
**Correct driving posture**

- A** Adjust the angle of the seatback so that you are sitting straight up and so that you do not have to lean forward to steer. (→P.134)
- B** Adjust the seat so that you can depress the pedals fully and so that your arms bend slightly at the elbow when gripping the steering wheel. (→P.134)
- C** Lock the head restraint in place with the center of the head restraint closest to the top of your ears. (→P.140)
- D** Wear the seat belt correctly. (→P.30)

**WARNING**

Observe the following precautions. Failure to do so may result in death or serious injury.

- Do not adjust the position of the driver's seat while driving. Doing so could cause the driver to lose control of the vehicle.
- Do not place a cushion between the driver or passenger and the seat-back. A cushion may prevent correct posture from being achieved, and reduce the effectiveness of the seat belt and head restraint.
- Do not place anything under the front seats.  
Objects placed under the front seats may become jammed in the seat tracks and stop the seat from locking in place. This may lead to an accident and the adjustment mechanism may also be damaged.
- Always observe the legal speed limit when driving on public roads.
- When driving over long distances, take regular breaks before you start to feel tired.  
Also, if you feel tired or sleepy while driving, do not force yourself to continue driving and take a break immediately.

**Adjusting the mirrors**

Make sure that you can see backward clearly by adjusting the inside rear view mirror (if equipped), Digital Rear-view Mirror (if equipped) and outside rear view mirrors properly. (→P.143, 144, 153)

**Correct use of the seat belts**

Make sure that all occupants are wearing their seat belts before driving the vehicle. (→P.30)

Use a child restraint system appropriate for the child until the child becomes large enough to properly wear the vehicle's seat belt. (→P.42)

## Seat belts

**Make sure that all occupants are wearing their seat belts before driving the vehicle.**

### WARNING

Observe the following precautions to reduce the risk of injury in the event of sudden braking, sudden swerving or an accident.  
Failure to do so may cause death or serious injury.

#### ■ Wearing a seat belt

- Ensure that all passengers wear a seat belt.
- Always wear a seat belt properly.
- Each seat belt should be used by one person only. Do not use a seat belt for more than one person at once, including children.
- Toyota recommends that children be seated in the rear seat and always use a seat belt and/or an appropriate child restraint system.
- To achieve a proper seating position, do not recline the seat more than necessary. The seat belt is most effective when the occupants are sitting up straight and well back in the seats.
- Do not wear the shoulder belt under your arm.
- Always wear your seat belt low and snug across your hips.

#### ■ Pregnant women

Obtain medical advice and wear the seat belt in the proper way. (→P.30)

Women who are pregnant should position the lap belt as low as possible over the hips in the same manner as other occupants, extending the shoulder belt completely over the shoulder and avoiding belt contact with the rounding of the abdominal area.

If the seat belt is not worn properly, not only the pregnant woman, but also the fetus could suffer death or serious injury as a result of sudden braking or a collision.

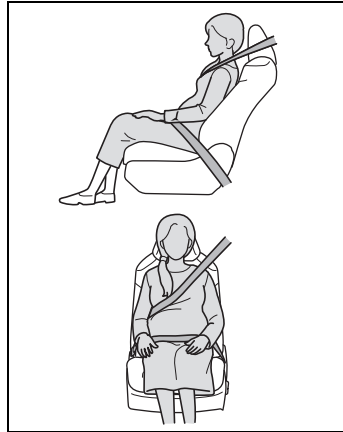

#### ■ People suffering illness

Obtain medical advice and wear the seat belt in the proper way. (→P.30)

#### ■ When children are in the vehicle

→P.52

#### ■ Seat belt damage and wear

- Do not damage the seat belts by allowing the belt, plate, or buckle to be jammed in the door.

**WARNING**

- Inspect the seat belt system periodically. Check for cuts, fraying, and loose parts. Do not use a damaged seat belt until it is replaced. Damaged seat belts cannot protect an occupant from death or serious injury.
- Ensure that the belt and plate are locked and the belt is not twisted. If the seat belt does not function correctly, immediately contact your Toyota dealer.
- Replace the seat assembly, including the belts, if your vehicle has been involved in a serious accident, even if there is no obvious damage.
- Do not attempt to install, remove, modify, disassemble or dispose of the seat belts. Have any necessary repairs carried out by your Toyota dealer. Inappropriate handling may lead to incorrect operation.

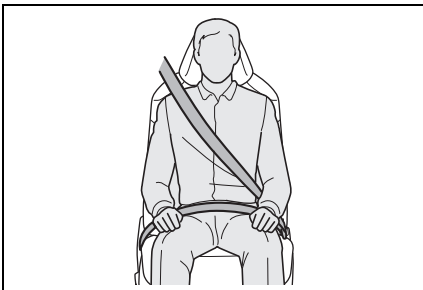
**Correct use of the seat belts**

- Extend the shoulder belt so that it comes fully over the shoulder, but does not come into contact with the neck or slide off the shoulder.
- Position the lap belt as low as possible over the hips.
- Adjust the position of the seat-

back.

Sit up straight and well back in the seat.

- Do not twist the seat belt.

**Child seat belt usage**

The seat belts of your vehicle were principally designed for persons of adult size.

- Use a child restraint system appropriate for the child, until the child becomes large enough to properly wear the vehicle's seat belt. (→P.42)
- When the child becomes large enough to properly wear the vehicle's seat belt, follow the instructions regarding seat belt usage. (→P.29)

**Seat belt regulations**

If seat belt regulations exist in the country where you reside, please contact your Toyota dealer for seat belt replacement or installation.

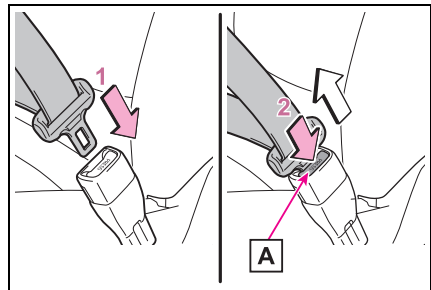
**Fastening and releasing the seat belt**

- 1 To fasten the seat belt, push the plate into the buckle until a click sound is heard.
- 2 To release the seat belt, press the release button **A**.



### ■ Emergency locking retractor (ELR)

The retractor will lock the belt during a sudden stop or on impact. It may also lock if you lean forward too quickly. A slow, easy motion will allow the belt to extend so that you can move around fully.

### Adjusting the seat belt shoulder anchor height (front seats)

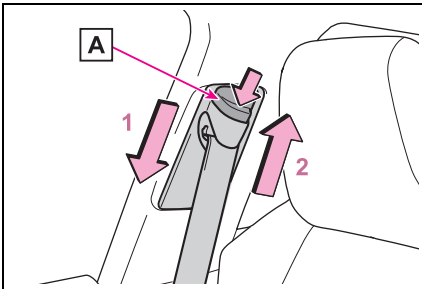

- 1 Push the seat belt shoulder anchor down while pressing the release button **A**.
- 2 Push the seat belt shoulder anchor up while pressing the release button **A**.

Move the height adjuster up and down as needed until you hear a click.



#### WARNING

#### ■ Adjustable shoulder anchor

Always make sure the shoulder belt is positioned across the center of your shoulder. The belt should be kept away from your neck, but not falling off your shoulder. Failure to do so could reduce the amount of protection in an accident and cause death or serious injuries in the event of a sudden stop, sudden swerve or accident.

### Seat belt pretensioners (front and outboard rear seats)

The pretensioners help the seat belts to quickly restrain the occupants by retracting the seat belts when the vehicle is subjected to certain types of severe frontal or side collision.

The pretensioners do not activate in the event of a minor frontal impact, a minor side impact, a rear impact or a vehicle rollover.

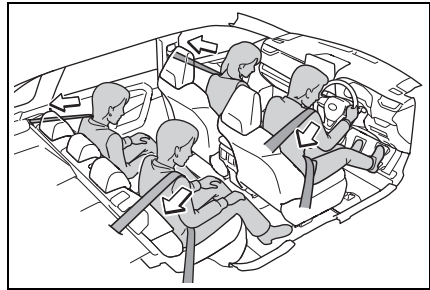

### ■ Replacing the belt after the pretensioner has been activated

If the vehicle is involved in multiple collisions, the pretensioner will activate for the first collision, but will not activate for the second or subsequent collisions.



#### WARNING

#### ■ Seat belt pretensioners

If the pretensioner has activated, the SRS warning light will come on. In that case, the seat belt cannot be used again and must be replaced at your Toyota dealer. Failure to do so may cause death or serious injury.

## SRS airbags

The SRS airbags inflate when the vehicle is subjected to certain types of severe impacts that may cause significant injury to the occupants. They work together with the seat belts to help reduce the risk of death or serious injury.

### SRS airbag system

#### ■ Location of the SRS airbags

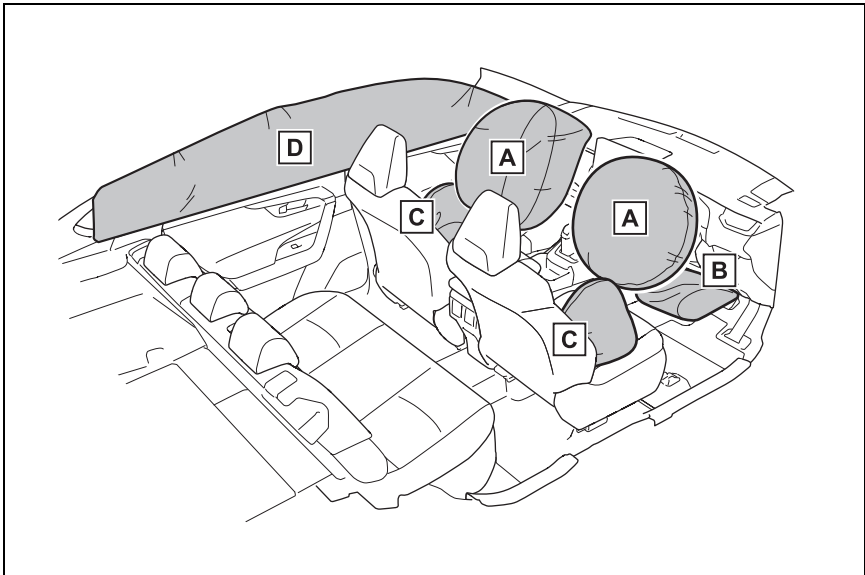

#### ► SRS front airbags

##### **A** SRS driver airbag/front passenger airbag

Can help protect the head and chest of the driver and front passenger from impact with interior components

##### **B** SRS knee airbag

Can help provide driver protection

#### ► SRS side and curtain shield airbags

##### **C** SRS side airbags

Can help protect the torso of the front seat occupants

##### **D** SRS curtain shield airbags

Can help protect primarily the head of occupants in the outboard seats

### ■ SRS airbag system components

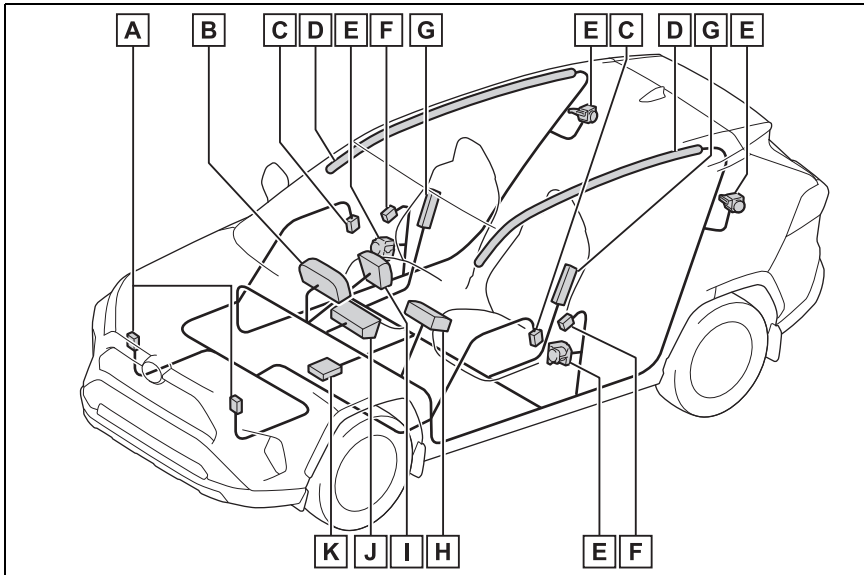

- A** Front impact sensors
- B** SRS warning light
- C** Side impact sensors (front door)
- D** Curtain shield airbags
- E** Seat belt pretensioners and force limiters
- F** Side impact sensors (front)
- G** Side airbags
- H** Front passenger airbag
- I** Driver airbag
- J** Knee airbag
- K** Airbag sensor assembly

The main SRS airbag system components are shown above. The SRS airbag system is controlled by the airbag sensor assembly. As the airbags deploy, a chemical reaction in the inflators quickly fills the airbags with non-toxic gas to help restrain the motion of the occupants.

### ■ If the SRS airbags deploy (inflate)

- Slight abrasions, burns, bruising etc., may be sustained from SRS airbags, due to the extremely high speed deployment (inflation) by hot gases.
- A loud noise and white powder will be emitted.
- Parts of the airbag module (steering wheel hub, airbag cover and inflator) as well as the front seats, parts of the front and rear pillars, and roof side rails, may be hot for several minutes. The airbag itself may also be hot.
- The windshield may crack.
- The hybrid system will be stopped and fuel supply to the engine will be stopped. (→P.66)
- All of the doors will be unlocked. (→P.116)
- Vehicles with Secondary Collision Brake: The brakes and stop lights will be controlled automatically. (→P.282)
- The interior lights will turn on automatically. (→P.306)
- The emergency flashers will turn on automatically. (→P.376)
- Vehicles with Toyota Connected Services: If any of the following situations occur, the system is designed to send an emergency call to the Toyota Connected Services control center, notifying them of the vehicle's location (without needing to push the "SOS" button) and an agent will attempt to speak with the occupants to ascertain the level of emergency and assistance required. If the occupants are unable to communicate, the agent automatically treats the call as an emergency and helps to dispatch the necessary emergency services. (→P.56)
  - An SRS airbag is deployed.
  - A seat belt pretensioner is activated.
  - The vehicle is involved in a severe rear-end collision.

### ■ SRS airbag deployment conditions (SRS front airbags)

- The SRS front airbags will deploy in the event of an impact that exceeds the set threshold level (the level of force corresponding to an approximately 20 - 30 km/h [12 - 18 mph] frontal collision with a fixed wall that does not move or deform).

However, this threshold velocity will be considerably higher in the following situations:

- If the vehicle strikes an object, such as a parked vehicle or sign pole, which can move or deform on impact
- If the vehicle is involved in an under-ride collision, such as a collision in which the front of the vehicle under-rides, or goes under, the bed of a truck
- Depending on the type of collision, it is possible that only the seat belt pretensioners will activate.

### ■ SRS airbag deployment conditions (SRS side and curtain shield airbags)

- The SRS side and curtain shield airbags will deploy in the event of an impact that exceeds the set threshold level (the level of force corresponding to the impact force produced by an approximately 1500 kg [3300 lb.] vehicle colliding with the vehicle cabin from a direction perpendicular to the vehicle orientation at an approximate speed of 20 - 30 km/h [12 - 18 mph]).
- Both SRS curtain shield airbags may also deploy in the event of a severe frontal collision.

### ■ Conditions under which the SRS airbags may deploy (inflate), other than a collision

The SRS front airbags and SRS curtain shield airbags may also deploy if a serious impact occurs to the underside of your vehicle. Some examples are shown in the illustration.

- Hitting a curb, edge of pavement or

hard surface

- Falling into or jumping over a deep hole
- Landing hard or falling

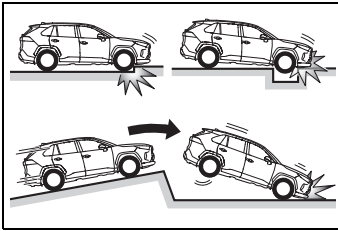

### ■ Types of collisions that may not deploy the SRS airbags (SRS front airbags)

The SRS front airbags do not generally inflate if the vehicle is involved in a side or rear collision, if it rolls over, or if it is involved in a low-speed frontal collision. But, whenever a collision of any type causes sufficient forward deceleration of the vehicle, deployment of the SRS front airbags may occur.

- Collision from the side
- Collision from the rear
- Vehicle rollover

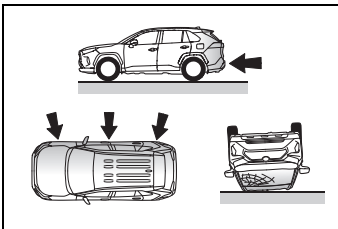

### ■ Types of collisions that may not deploy the SRS airbags (SRS side and curtain shield airbags)

The SRS side and curtain shield airbags may not activate if the vehicle is subjected to a collision from the side at certain angles, or a collision to the side of the vehicle body other than the passenger compartment.

- Collision from the side to the vehicle body other than the passenger compartment

- Collision from the side at an angle

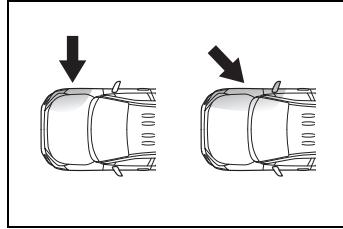

The SRS side airbags do not generally inflate if the vehicle is involved in a frontal or rear collision, if it rolls over, or if it is involved in a low-speed side collision.

- Collision from the front
- Collision from the rear
- Vehicle rollover

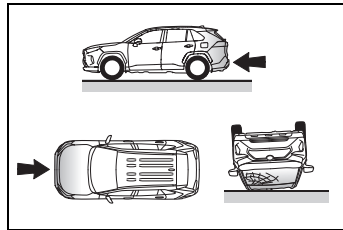

The SRS curtain shield airbags do not generally inflate if the vehicle is involved in a rear collision, if it rolls over, or if it is involved in a low-speed side or low-speed frontal collision.

- Collision from the rear
- Vehicle rollover

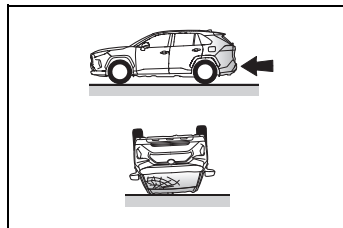

### ■ When to contact your Toyota dealer

In the following cases, the vehicle will require inspection and/or repair. Contact your Toyota dealer as soon as possible.

- Any of the SRS airbags have been inflated.

- The front of the vehicle is damaged or deformed, or was involved in an accident that was not severe enough to cause the SRS front airbags to inflate.

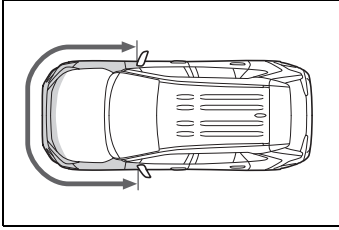

- A portion of a door or its surrounding area is damaged, deformed or has had a hole made in it, or the vehicle was involved in an accident that was not severe enough to cause the SRS side and curtain shield airbags to inflate.

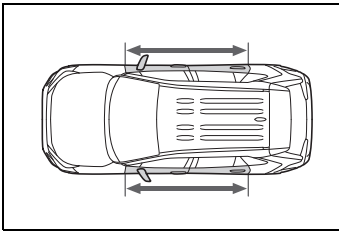

- The pad section of the steering wheel, dashboard near the front passenger airbag or lower portion of the instrument panel is scratched, cracked, or otherwise damaged.

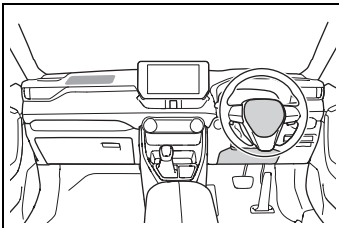

- The surface of the seats with the SRS side airbag is scratched, cracked, or otherwise damaged.

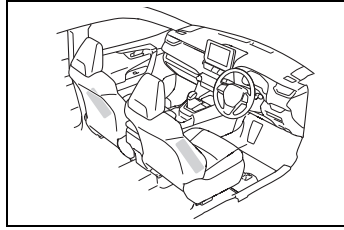

- The portion of the front pillars, rear pillars or roof side rail garnishes (padding) containing the SRS curtain shield airbags inside is scratched, cracked, or otherwise damaged.

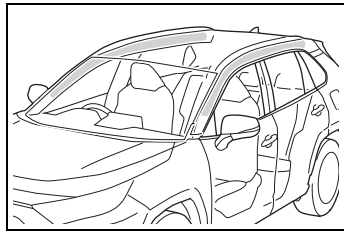

### WARNING

#### ■ SRS airbag precautions

Observe the following precautions regarding the SRS airbags. Failure to do so may cause death or serious injury.

- The driver and all passengers in the vehicle must wear their seat belts properly. The SRS airbags are supplemental devices to be used with the seat belts.

## WARNING

- The SRS driver airbag deploys with considerable force, and can cause death or serious injury especially if the driver is very close to the airbag.

Since the risk zone for the driver's airbag is the first 50 - 75 mm (2 - 3 in.) of inflation, placing yourself 250 mm (10 in.) from your driver airbag provides you with a clear margin of safety. This distance is measured from the center of the steering wheel to your breastbone. If you sit less than 250 mm (10 in.) away now, you can change your driving position in several ways:

- Move your seat to the rear as far as you can while still reaching the pedals comfortably.
- Slightly recline the back of the seat. Although vehicle designs vary, many drivers can achieve the 250 mm (10 in.) distance, even with the driver seat all the way forward, simply by reclining the back of the seat somewhat. If reclining the back of your seat makes it hard to see the road, raise yourself by using a firm, non-slippery cushion, or raise the seat if your vehicle has that feature.
- If your steering wheel is adjustable, tilt it downward. This points the airbag toward your chest instead of your head and neck.

The seat should be adjusted as recommended above, while still maintaining control of the foot pedals, steering wheel, and your view of the instrument panel controls.

- The SRS front passenger airbag also deploys with considerable force, and can cause death or serious injury especially if the front passenger is very close to the airbag. The front passenger seat should be as far from the airbag as possible with the seatback adjusted, so the front passenger sits upright.
- Improperly seated and/or restrained infants and children can be killed or seriously injured by a deploying airbag. An infant or child who is too small to use a seat belt should be properly secured using a child restraint system. Toyota strongly recommends that all infants and children be placed in the rear seats of the vehicle and properly restrained. The rear seats are safer for infants and children than the front passenger seat. (→P.42)
- Do not sit on the edge of the seat or lean against the dashboard.

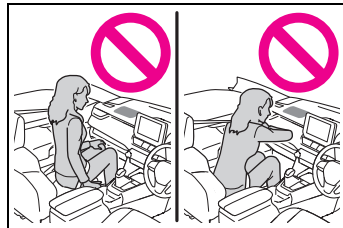

- Do not allow a child to stand in front of the SRS front passenger airbag unit or sit on the knees of a front passenger.

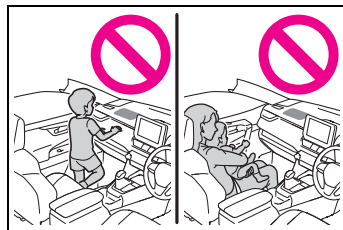

- Do not allow the front seat occupants to hold items on their knees.

**! WARNING**

- Do not lean against the door, the roof side rail or the front, side and rear pillars.



- Do not allow anyone to kneel on the passenger seat toward the door or put their head or hands outside the vehicle.

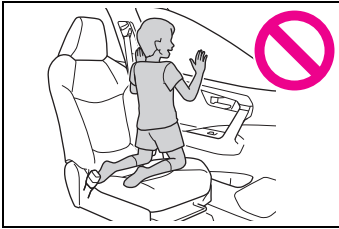

- Do not attach anything to or lean anything against areas such as the dashboard, steering wheel pad and lower portion of the instrument panel. These items can become projectiles when the SRS driver, front passenger and knee airbags deploy.

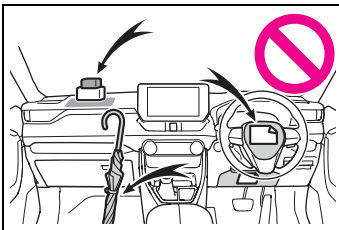

- Do not attach anything to areas such as a door, windshield, side window, front or rear pillar, roof side rail and assist grip.

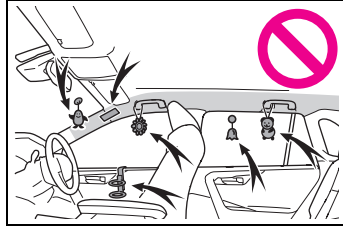

- Do not hang coat hangers or other hard objects on the coat hooks. All of these items could become projectiles and may cause death or serious injury, should the SRS curtain shield airbags deploy.
- If a vinyl cover is put on the area where the SRS knee airbag will deploy, be sure to remove it.
- Do not use seat accessories which cover the parts where the SRS side airbags inflate as they may interfere with inflation of the SRS airbags. Such accessories may prevent the SRS side airbags from activating correctly, disable the system or cause the SRS side airbags to inflate accidentally, resulting in death or serious injury.
- Do not strike or apply significant levels of force to the area of the SRS airbag components or the front doors. Doing so can cause the SRS airbags to malfunction.
- Do not touch any of the component parts immediately after the SRS airbags have deployed (inflated) as they may be hot.



**WARNING**

- If breathing becomes difficult after the SRS airbags have deployed, open a door or window to allow fresh air in, or leave the vehicle if it is safe to do so. Wash off any residue as soon as possible to prevent skin irritation.
  - If the areas where the SRS airbags are stored, such as the steering wheel pad and front and rear pillar garnishes, are damaged or cracked, have them replaced by your Toyota dealer.
- Modification and disposal of SRS airbag system components**
- Do not dispose of your vehicle or perform any of the following modifications without consulting your Toyota dealer. The SRS airbags may malfunction or deploy (inflate) accidentally, causing death or serious injury.
- Installation, removal, disassembly and repair of the SRS airbags
  - Repairs, modifications, removal or replacement of the steering wheel, instrument panel, dashboard, seats or seat upholstery, front, side and rear pillars, roof side rails, front door panels, front door trims or front door speakers
  - Modifications to the front door panel (such as making a hole in it)
  - Repairs or modifications of the front fender, front bumper, or side of the occupant compartment
  - Installation of a grille guard (bull bars, kangaroo bar, etc.), snow plows or winches
  - Modifications to the vehicle's suspension system
  - Installation of electronic devices such as mobile two-way radios (RF-transmitter) and CD players

**Exhaust gas precautions**

**Harmful substance to the human body is included in exhaust gases if inhaled.**

**WARNING**

Exhaust gases contain harmful carbon monoxide (CO), which is colorless and odorless. Observe the following precautions. Failure to do so may cause exhaust gases to enter the vehicle and may lead to an accident caused by light-headedness, or may lead to death or a serious health hazard.

**■ Important points while driving**

- Keep the back door closed.
- If you smell exhaust gases in the vehicle even when the back door is closed, open the side windows and have the vehicle inspected at your Toyota dealer as soon as possible.

**■ When parking**

- If the vehicle is in a poorly ventilated area or a closed area, such as a garage, stop the hybrid system.
- Do not leave the vehicle with the hybrid system operating for a long time. If such a situation cannot be avoided, park the vehicle in an open space and ensure that exhaust fumes do not enter the vehicle interior.
- Do not leave the hybrid system operating in an area with snow build-up, or where it is snowing. If snowbanks build up around the vehicle while the hybrid system is operating, exhaust gases may collect and enter the vehicle.

**WARNING****■ Exhaust pipe**

The exhaust system needs to be checked periodically. If there is a hole or crack caused by corrosion, damage to a joint or abnormal exhaust noise, be sure to have the vehicle inspected and repaired by your Toyota dealer.

## Riding with children

**Observe the following precautions when children are in the vehicle.**

**Use a child restraint system appropriate for the child, until the child becomes large enough to properly wear the vehicle's seat belt.**

- It is recommended that children sit in the rear seats to avoid accidental contact with the shift lever, wiper switch, etc.
- Use the rear door child-protector lock or the window lock switch to avoid children opening the door while driving or operating the power window accidentally. (→P.118, 157)
- Do not let small children operate equipment which may catch or pinch body parts, such as the power window, hood, back door, seats, etc.



### WARNING

#### ■ When children are in the vehicle

Never leave children unattended in the vehicle, and never allow children to have or use the key.

Children may be able to start the vehicle or shift the vehicle into neutral.

There is also a danger that children may injure themselves by playing with the side windows, the moon roof (if equipped) or other features of the vehicle. In addition, heat build-up or extremely cold temperatures inside the vehicle can be fatal to children.

## Child restraint systems

**Before installing a child restraint system in the vehicle, there are precautions that need to be observed, different types of child restraint systems, as well as installation methods, etc., written in this manual.**

- Use a child restraint system when riding with a small child that cannot properly use a seat belt. For the child's safety, install the child restraint system to a rear seat. Be sure to follow the installation method that is in the operation manual enclosed with the restraint system.

## Table of contents

Points to remember: P.42

When using a child restraint system: P.43

Child restraint system compatibility for each seating position: P.45

Child restraint system installation method: P.49

- Fixed with a seat belt: P.50
- Fixed with an ISOFIX rigid anchor: P.52
- Using a child restraint anchor fitting: P.53

## Points to remember

- Prioritize and observe the warn-

ings, as well as the laws and regulations for child restraint systems.

- Use a child restraint system until the child becomes large enough to properly wear the vehicle's seat belt.
- Choose a child restraint system appropriate to the age and size of the child.
- Note that not all child restraint systems can fit in all vehicles. Before using or purchasing a child restraint system, check the compatibility of the child restraint system with seat positions. (→P.45)



## WARNING

### ■ When a child is riding

Observe the following precautions. Failure to do so may result in death or serious injury.

- For effective protection in automobile accidents and sudden stops, a child must be properly restrained, using a seat belt or child restraint system which is correctly installed. For installation details, refer to the operation manual enclosed with the child restraint system. General installation instructions are provided in this manual.
- Toyota strongly urges the use of a proper child restraint system that conforms to the weight and size of the child, installed on the rear seat. According to accident statistics, the child is safer when properly restrained in the rear seat than in the front seat.

## WARNING

- Holding a child in your or someone else's arms is not a substitute for a child restraint system. In an accident, the child can be crushed against the windshield or between the holder and the interior of the vehicle.

### ■ Handling the child restraint system

If the child restraint system is not properly fixed in place, the child or other passengers may be seriously injured or even killed in the event of sudden braking, sudden swerving, or an accident.

- If the vehicle were to receive a strong impact from an accident, etc., it is possible that the child restraint system has damage that is not readily visible. In such cases, do not reuse the restraint system.
- Depending on the child restraint system, installation may be difficult or impossible. In those cases, check whether the child restraint system is suitable for installment in the vehicle (→P.45). Be sure to install and observe the usage rules after carefully reading the child restraint system fixing method in this manual, as well as the operation manual enclosed with the child restraint system.
- Keep the child restraint system properly secured on the seat even if it is not in use. Do not store the child restraint system unsecured in the passenger compartment.
- If it is necessary to detach the child restraint system, remove it from the vehicle or store it securely in the luggage compartment.

## When using a child restraint system

### ■ When installing a child restraint system to a front passenger seat

For the safety of a child, install a child restraint system to a rear seat. When installing a child restraint system to the front passenger seat is unavoidable, adjust the seat as follows and install the child restraint system:

- Adjust the seatback angle to the most upright position.

If there is a gap between the child seat and the seatback, adjust the seatback angle until good contact is achieved.

- Move the front seat fully rearward. If the passenger seat height can be adjusted, move it to the upper most position.
- If the head restraint interferes with the child restraint system installation and the head restraint can be removed, remove the head restraint. Otherwise, put the head restraint in the upper most position.

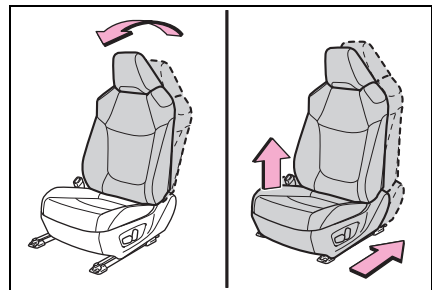

**WARNING**

■ **When using a child restraint system**

Observe the following precautions. Failure to do so may result in death or serious injury.

- **Extreme Hazard!** Do not use a rearward facing child restraint on a seat protected by an airbag in front of it! This is because the force of the rapid inflation of the front passenger airbag can cause death or serious injury to the child.

There is a label(s) on the passenger side sun visor, indicating it is forbidden to attach a rear-facing child restraint system to the front passenger seat.

Details of the label(s) are shown in the illustration below.

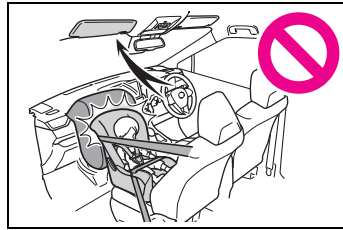
**WARNING**

## ⚠ WARNING

- Only put a forward-facing child restraint system on the front seat when unavoidable. When installing a forward-facing child restraint on the front passenger seat, move the seat as far back as possible. Failing to do so may result in death or serious injury if the airbags deploy (inflate).



- Do not allow the child to lean his/her head or any part of his/her body against the door or the area of the seat, front or rear pillars, or roof side rails from which the SRS side airbags or SRS curtain shield airbags deploy even if the child is seated in the child restraint system. It is dangerous if the SRS side airbags and curtain shield airbags inflate, and the impact could cause death or serious injury to the child.



- When a junior seat (booster seat) is installed, always ensure that the shoulder belt is positioned across the center of the child's shoulder. The belt should be kept away from the child's neck, but not so that it could fall off the child's shoulder.

- Use a child restraint system suitable to the age and size of the child and install it to the rear seat.
- If the driver's seat interferes with the child restraint system and prevents it from being attached correctly, attach the child restraint system to the left-hand rear seat.

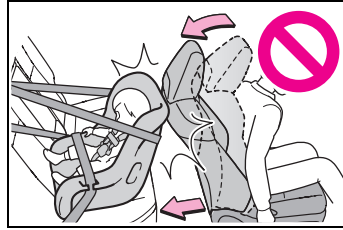

- Adjust the front passenger seat so that it does not interfere with the child restraint system.

## Child restraint system compatibility for each seating position

### ■ Child restraint system compatibility for each seating position

Compatibility of each seating position with child restraint systems (→P.47) displays the type of child restraint systems that can be used and possible seating positions for installation using symbols.

Check the selected child restraint system together with the following [Before confirming the compatibility of each seating position with child restraint systems].

■ **Before confirming the compatibility of each seating position with child restraint systems**

1 Checking the child restraint system standards.

Use a child restraint system that conforms to UN(ECE) R44\*<sup>1</sup> or UN(ECE) R129\*<sup>1, 2</sup>.

The following approval mark is displayed on child restraint systems which are conformed. Check for an approval mark attached to the child restraint system.

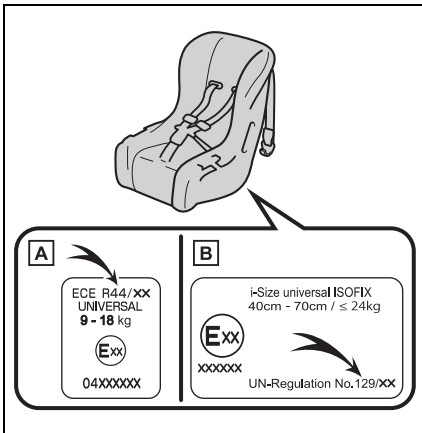

Example of the displayed regulation Number

**A** UN(ECE) R44 approval mark\*<sup>3</sup>

The weight range of the child who is applicable for an UN(ECE) R44 approval mark is indicated.

**B** UN(ECE) R129 approval mark\*<sup>3</sup>

The height range of the child who is applicable as well as available weights for an

UN(ECE) R129 approval mark is indicated.

2 Checking the category of the child restraint system.

Check the approval mark of the child restraint system for which of the following categories the child restraint system is suitable. Also, if there are any uncertainties, check the user's guide included with the child restraint system or contact the retailer of the child restraint system.

- “universal”
- “semi-universal”
- “restricted”
- “vehicle specific”

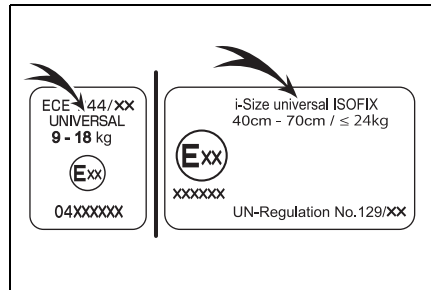

\*<sup>1</sup>: UN(ECE) R44 and UN(ECE) R129 are U.N. regulations for child restraint systems.

\*<sup>2</sup>: The child restraint systems mentioned in the table may not be available outside of the EU area.

\*<sup>3</sup>: The displayed mark may differ depending on the product.



■ **Compatibility of each seating position with child restraint systems**

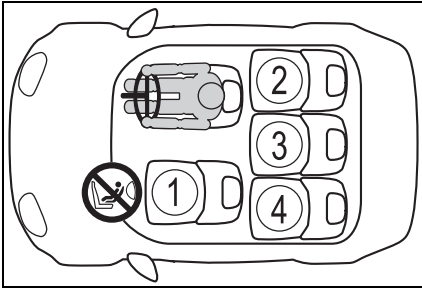

<p>①</p> <p>*1, 2, 3</p>	
<p>②</p> <p>*2, 3</p>	
<p>③</p> <p>*2, 3</p>	
<p>④</p> <p>*2, 3</p>	



Suitable for fixed with vehicle seat belt “universal” category child restraint system.



Suitable for i-Size and ISOFIX child restraint system.



Includes a top tether anchorage point.



Never use a rear-facing child restraint system on the front passenger seat.

\*1: Move the front seat fully rearward. If the passenger seat height can be adjusted, move it to the upper most position.

\*2: Adjust the seatback angle to the most upright position. When installing a forward-facing child seat, if there is a gap between the child seat and the seatback, adjust the seatback angle until good contact is achieved.

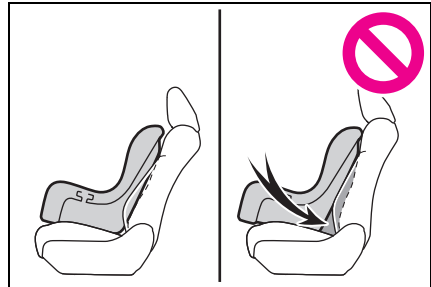

\*3: If the head restraint interferes with your child restraint system, and the head restraint can be removed, remove the head restraint. Otherwise, put the head restraint in the upper most position.

\*4: Use only a front-facing child restraint system.

### ■ Detail information for child restraint systems installation

Seating position				
Seat position number	①	②	③	④
Seating position suitable for universal belted (Yes/No)	Yes Forward facing only	Yes	Yes	Yes
i-Size seating position (Yes/No)	No	Yes	No	Yes
Seating position suitable for lateral fixture (L1/L2/No)	No	No	No	No
Suitable rearward facing fixture (R1/R2X/R2/R3/No)	No	R1, R2X, R2, R3	No	R1, R2X, R2, R3
Suitable forward facing fixture (F2X/F2/F3/No)	No	F2X, F2, F3	No	F2X, F2, F3
Suitable junior seat fixture (B2/B3/No)	No	B2, B3	No	B2, B3

ISOFIX child restraint systems are divided into different “fixture”. The child restraint system can be used in the seating positions for “fixture” mentioned in the table above. For kind of “fixture” relation, confirm the following table. If your child restraint system has no kind of “fixture” (or if you cannot find information in the table below), please refer to the child restraint system “vehicle list” for compatibility information or ask the retailer of your child seat.

Fixture	Description
F3	Full-height, forward-facing child restraint systems
F2	Reduced-height forward-facing child restraint systems
F2X	Reduced-height forward-facing child restraint systems
R3	Full-size, rearward-facing child restraint systems
R2	Reduced-size, rearward-facing child restraint systems
R2X	Reduced-size, rearward-facing child restraint systems
R1	Rearward-facing infant seat
L1	Left lateral-facing (carrycot) infant seat
L2	Right lateral-facing (carrycot) infant seat

Fixture	Description
B2	Junior seat
B3	Junior seat

When securing some types of child restraint systems in rear seat, it may not be possible to properly use the seat belts in positions next to the child restraint without interfering with it or affecting seat belt effectiveness. Be sure your seat belt fits snugly across your shoulder and low on your hips. If it does not, or if it interferes with the child restraint, move to a different position. Failure to do so may result in death or serious injury.

- When installing a child restraint in the rear seats, adjust the front seat so that it does not interfere with the child or child restraint system.
- When installing a child seat with support base, if the child seat interferes with the seatback when latching it into the support base, adjust the seatback rearward until there is no interfer-

ence.

- If the seat belt shoulder anchor is ahead of the child seat belt guide, move the seat cushion forward.

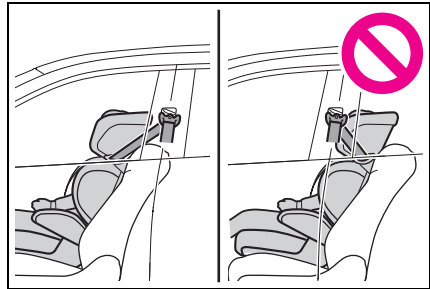

- When installing a junior seat, if the child in your child restraint system is in a very upright position, adjust the seatback angle to the most comfortable position. And if the seat belt shoulder anchor is ahead of the child seat belt guide, move the seat cushion forward.

### Child restraint system installation method

Confirm with the operation manual enclosed with the child restraint system about the installation of the child restraint system.

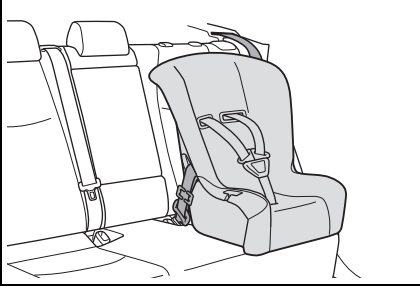
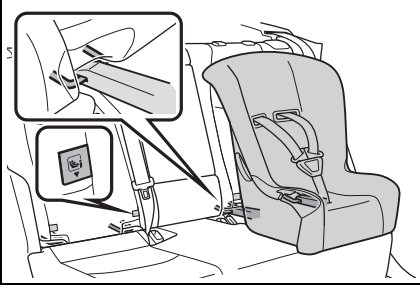
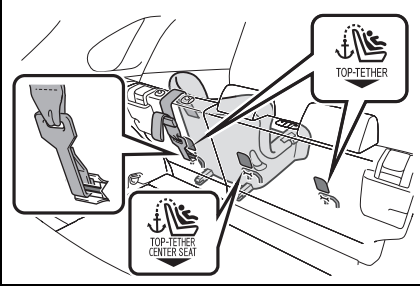
	Installation method	Page
Seat belt attachment		P.50
ISOFIX rigid anchor attachment		P.52
Child restraint anchor fitting attachment		P.53

### Child restraint system fixed with a seat belt

#### ■ Installing child restraint system using a seat belt

Install the child restraint system in accordance to the operation manual enclosed with the child restraint system.

If the child restraint system on hand

is not within the “universal” category (or the necessary information is not in the table), refer to the “Vehicle List” provided by the child restraint system maker for various possible installation positions, or check the compatibility after asking the retailer of the child seat.

(→P.46, 47)

- 1 If installing the child restraint system to the front passenger seat is unavoidable, refer to P.43 for the front passenger seat adjustment.
- 2 Adjust the seatback angle to the most upright position. When installing a forward-facing child seat, if there is a gap between the child seat and the seatback, adjust the seatback angle until good contact is achieved.
- 3 If the head restraint interferes with the child restraint system installation and the head restraint can be removed, remove the head restraint. Otherwise, put the head restraint in the upper most position. (→P.140)
- 4 Run the seat belt through the child restraint system and insert the plate into the buckle. Make sure that the belt is not twisted. Securely fix the seat belt to the child restraint system in accordance to the directions enclosed with the child restraint system.

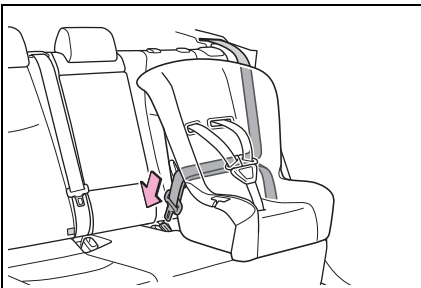

- 5 If your child restraint system is not equipped with a lock-off (a seat belt locking feature), secure the child restraint system using a locking clip.

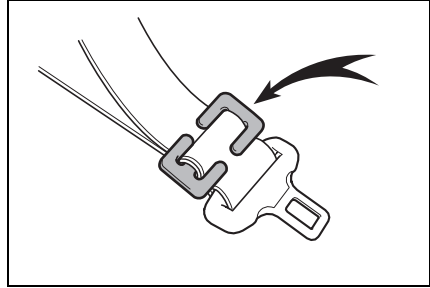

- 6 After installing the child restraint system, rock it back and forth to ensure that it is installed securely. (→P.52)

#### ■ Removing a child restraint system installed with a seat belt

Press the buckle release button and fully retract the seat belt.

When releasing the buckle, the child restraint system may spring up due to the rebound of the seat cushion. Release the buckle while holding down the child restraint system.

Since the seat belt automatically reels itself, slowly return it to the stowing position.

#### ■ When installing a child restraint system

You may need a locking clip to install the child restraint system. Follow the instructions provided by the manufacturer of the system. If your child restraint system does not provide a locking clip, you can purchase the following item from your Toyota dealer: Locking clip for

child restraint system  
(Part No. 73119-22010)

**⚠ WARNING**

**■ When installing a child restraint system**

Observe the following precautions. Failure to do so may result in death or serious injury.

- Do not allow children to play with the seat belt. If the seat belt becomes twisted around a child's neck, it may lead to choking or other serious injuries that could result in death. If this occurs and the buckle cannot be unfastened, scissors should be used to cut the belt.
- Ensure that the belt and plate are securely locked and the seat belt is not twisted.
- Shake the child restraint system left and right, and forward and backward to ensure that it has been securely installed.
- After securing a child restraint system, never adjust the seat.
- When a junior seat (booster seat) is installed, always ensure that the shoulder belt is positioned across the center of the child's shoulder. The belt should be kept away from the child's neck, but not so that it could fall off the child's shoulder.
- Follow all installation instructions provided by the child restraint system manufacturer.

**Child restraint system fixed with an ISOFIX rigid anchor**

**■ ISOFIX rigid anchors (ISOFIX child restraint system)**

Lower anchors are provided for the

outboard rear seats. (Tags displaying the location of the anchors are attached to the seats.)

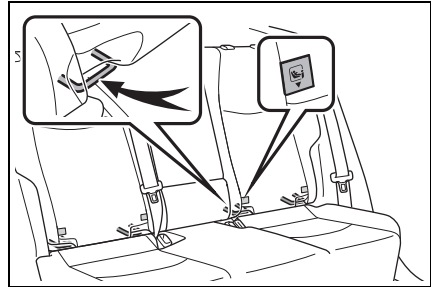

**■ Installation with ISOFIX rigid anchor (ISOFIX child restraint system)**

Install the child restraint system in accordance to the operation manual enclosed with the child restraint system.

If the child restraint system on hand is not within the “universal” category (or the necessary information is not in the table), refer to the “Vehicle List” provided by the child restraint system maker for various possible installation positions, or check the compatibility after asking the retailer of the child seat.

(→P.46, 47)

- 1 Adjust the seatback angle to the most upright position. When installing a forward-facing child seat, if there is a gap between the child seat and the seatback, adjust the seatback angle until good contact is achieved.
- 2 If the head restraint interferes with the child restraint system installation and the head

restraint can be removed, remove the head restraint. Otherwise, put the head restraint in the upper most position.

(→P.140)

- 3 Check the positions of the exclusive fixing bars, and install the child restraint system to the seat.

The bars are installed in the clearance between the seat cushion and seat-back.

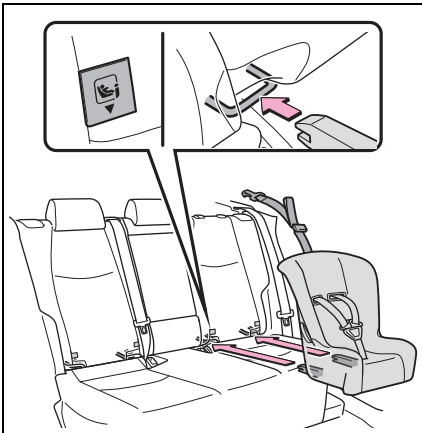

- 4 After installing the child restraint system, rock it back and forth to ensure that it is installed securely. (→P.52)



### WARNING

#### ■ When installing a child restraint system

Observe the following precautions. Failure to do so may result in death or serious injury.

- After securing a child restraint system, never adjust the seat.

- When using the lower anchors, be sure that there are no foreign objects around the anchors and that the seat belt is not caught behind the child restraint system.

- Follow all installation instructions provided by the child restraint system manufacturer.

#### ■ Using child restraint anchorages

**WARNING:** child restraint anchorages are designed to withstand only those loads imposed by correctly fitted child restraints. Under no circumstances are they to be used for adult seatbelts, harnesses, or for attaching other items or equipment to the vehicle.

### Using a child restraint anchor fitting

#### ■ Child restraint anchor fitting

Anchor fittings are provided for each rear seat.

Use anchor fitting when fixing the strap.

#### ► Outboard rear seats

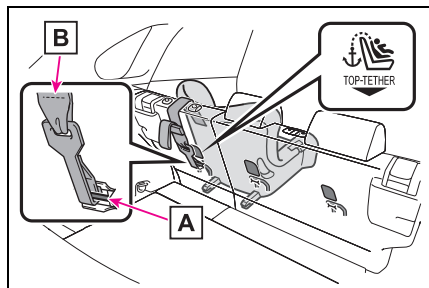

**A** Anchor fittings

**B** Upper anchorage strap

## ▶ Center rear seat

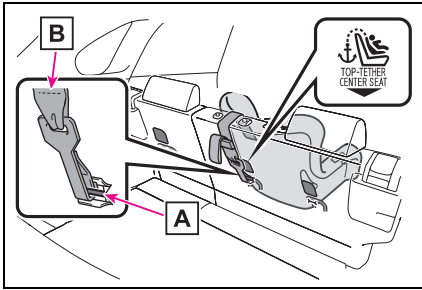

**A** Anchor fitting

**B** Upper anchorage strap

### ■ Fixing the strap to the anchor fitting

Install the child restraint system in accordance to the operation manual enclosed with the child restraint system.

- 1 Adjust the head restraint to the upmost position.

If the head restraint interferes with the child restraint system or top strap installation and the head restraint can be removed, remove the head restraint. (→P.140)

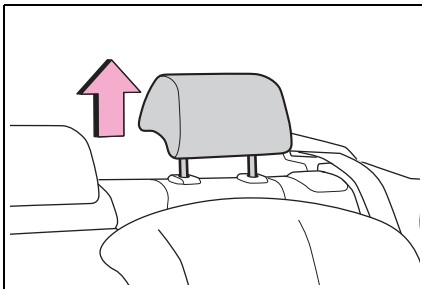

- 2 Latch the attaching clip onto the anchor fitting and tighten the upper anchorage strap.

Make sure the upper anchorage strap is securely latched. (→P.52)

When installing the child restraint system with the head restraint being raised, be sure to have the top strap pass underneath the head restraint.

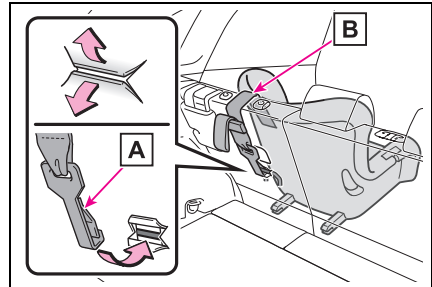

**A** Attaching clip

**B** Upper anchorage strap

### ⚠ WARNING

#### ■ When installing a child restraint system

Observe the following precautions. Failure to do so may result in death or serious injury.

- Firmly attach the upper anchorage strap and make sure that the belt is not twisted.
- Do not attach the upper anchorage strap to anything other than the anchor fitting.
- After securing a child restraint system, never adjust the seat.
- Follow all installation instructions provided by the child restraint system manufacturer.
- When installing the child restraint system with the head restraint being raised, after the head restraint has been raised and then the top tether anchorage has been fixed, do not lower the head restraint.



**WARNING****■ Using child restraint anchorages**

WARNING: child restraint anchorages are designed to withstand only those loads imposed by correctly fitted child restraints. Under no circumstances are they to be used for adult seatbelts, harnesses, or for attaching other items or equipment to the vehicle.

## Toyota Connected Services<sup>\*1, 2</sup>

\*1: If equipped

\*2: Operates within the Toyota Connected Services coverage.

**Toyota Connected Services are telematics services that use Global Positioning System (GPS) data and embedded cellular technology to enable the following emergency calls to be made: ACN (Automatic Collision Notification) and SOS Emergency Call (Manual emergency service notification) (by pressing the “SOS” button).**

**For more information about Toyota Connected Services, please visit:**

**<https://www.toyota.com.au/connected>**

### System components

► Type A

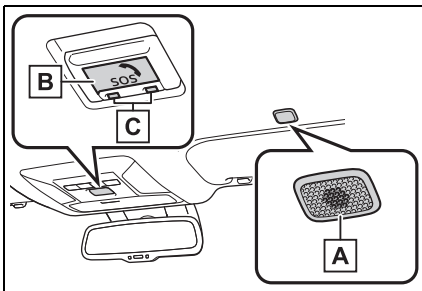

**A** Microphone

**B** “SOS” button<sup>\*</sup>

**C** Indicator lights

\*: This button is intended for communication with the Emergency Call Centre.

Other SOS buttons available in other systems of a motor vehicle do not relate to the device and are not intended for communication with the Emergency Call Centre.

► Type B

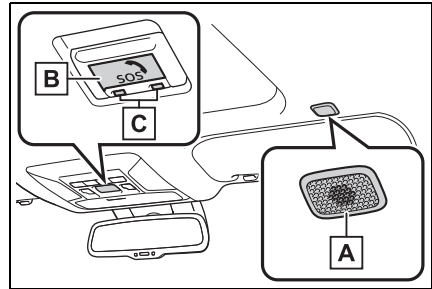

**A** Microphone

**B** “SOS” button<sup>\*</sup>

**C** Indicator lights

\*: This button is intended for communication with the Emergency Call Centre.

Other SOS buttons available in other systems of a motor vehicle do not relate to the device and are not intended for communication with the Emergency Call Centre.

### Toyota Connected Services

#### ■ ACN (Automatic Collision Notification)

If any airbag deploys, the system is designed to automatically call the Emergency Call Centre.\* The Call Centre Agent will determine your

vehicle's location, the time of the incident and the vehicle VIN, and attempt to speak with the vehicle occupants to assess the situation. If the occupants are unable to communicate, the Call Centre Agent automatically treats the call as an emergency and contacts emergency services to describe the situation and request that assistance be sent to the location.

\*: In some cases, the call cannot be made. (→P.58)

### ■ SOS Emergency Call (Manual emergency service notification)

In the event of an emergency, press the “SOS” button to call the Emergency Call Centre.\* The Call Centre Agent will determine your vehicle's location, assess the situation, and dispatch the necessary assistance required.

Make sure to open the cover before pressing the “SOS” button.

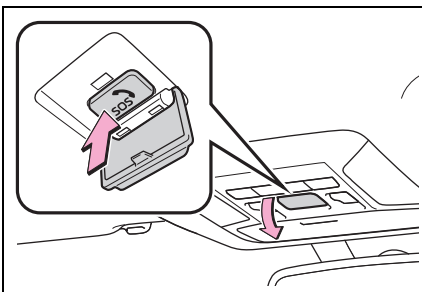

If you accidentally press the “SOS” button, tell the Call Centre Agent that you are not experiencing an emergency.

\*: In some cases, the call cannot be made. (→P.58)

## Indicator lights

When the power switch is turned to ON, the red/green indicator lights will blink intermittently, then the green indicator light will remain ON, indicating that the system is enabled. The indicator lights indicate the following:

- If the green indicator light illuminates and stays on, the system is enabled.
- If the green indicator light flashes twice per second, the ACN/SOS service is being made.
- If the red indicator light illuminates at any time other than immediately after the power switch is turned to ON, the system may be malfunctioning or the backup battery may be depleted. Contact your Toyota dealer.

### ■ Free/Open Source Software Information

This product contains Free/Open Source Software (FOSS). The license information and/or the source code of such FOSS can be found at the following URL.

<http://www.opensourceautomotive.com/dcm/19MC/>

**WARNING**

**■ When the ACN/SOS may not be made**

- It may not be possible to make ACN/SOS in any of the following situations. In such cases, report to emergency services provider (000 system etc.) by other means such as nearby public phones.
- Even when the vehicle is in the cellular phone service area, it may be difficult to connect to the Emergency Call Centre if the reception is poor or the line is busy. In such cases, you may not be able to connect to the Emergency Call Centre.
- When the vehicle is out of the cellular phone service area, the ACN/SOS cannot be made.
- When any related equipment (such as the “SOS” button panel, indicator lights, microphone, DCM, antenna, or any wires connecting the equipment) is malfunctioning, damaged or broken, the ACN/SOS cannot be made.
- Enabled Toyota vehicles collect and transmit vehicle data to provide connected services. SOS and Automatic Collision Notification may be disabled if green LED under SOS button is not illuminated. For more info including re-activation, visit <https://www.toyota.com.au/privacy>
- During an ACN/SOS service, the system makes repeated attempts to connect to the Emergency Call Centre. However, if it cannot connect to the Emergency Call Centre due to poor radio wave reception, the system may not be able to connect to the cellular network and the call may finish without connecting. A voice prompt notification will play from the vehicle speaker to indicate call disconnection.

- If the battery’s voltage decreases or there is a disconnection, the system may not be able to connect to the Emergency Call Centre.

- The ACN/SOS system might not work outside of Australia region, depending on the available infrastructure in the country.

**■ When the ACN/SOS system is replaced with a new one**

The ACN/SOS system should be registered. Contact your Toyota dealer.

**■ For your safety**

- Please drive safely.  
The function of this system is to assist you in contacting the appropriate emergency services in case of accidents such as traffic accidents or sudden medical emergencies, and it does not protect the driver or passengers in any way. Please drive safely and fasten your seatbelts at all times for your safety.
- In case of an emergency, ensure preservation of life is prioritised first.
- If you smell anything burning or other unusual smells, leave the vehicle and evacuate to a safe area immediately.
- If the airbags deploy when the system is operating normally, the system makes emergency call. The system also makes emergency call when the vehicle is struck from the rear or rolls over, even if the airbags do not deploy.
- For safety, do not press the SOS button while driving.  
Making calls during driving may cause mishandling of the steering wheel, which may lead to unexpected accidents.  
Stop the vehicle and confirm the safety of your surroundings before pressing the SOS button.

**WARNING**

- When changing fuses, please use the specified fuses. Using other fuses may cause ignition or smoke in the circuit and lead to a fire.
- Using the system while there is smoke or an unusual smell may cause a fire. Stop using the system immediately and consult your Toyota dealer.

**NOTICE****■ To prevent damage**

Do not pour any liquids onto the “SOS” button panel, etc. and do not impact it.

**■ If the “SOS” button panel, speaker or microphone malfunctions during an ACN/SOS service**

It may not be possible to make ACN/SOS, confirm the system status, or communicate with the Call Centre Agent. If any of the above equipment is damaged, please consult your Toyota dealer.

## Hybrid system features

Your vehicle is a Hybrid Electric Vehicle. It has characteristics different from conventional vehicles. Be sure you are closely familiar with the characteristics of your vehicle, and operate it with care.

The hybrid system combines the use of a gasoline engine and an electric motor (traction motor) according to driving conditions, improving fuel efficiency and reducing exhaust emissions.

## System components

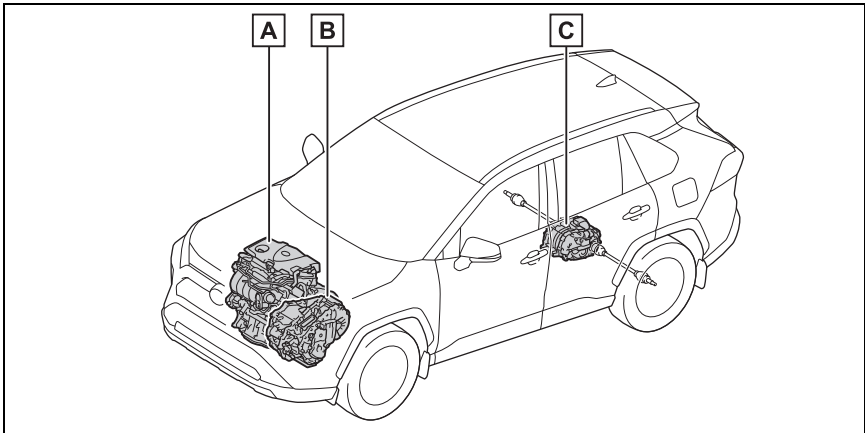

The illustration is an example for explanation and may differ from the actual item.

- A** Gasoline engine
- B** Front electric motor (traction motor)
- C** Rear electric motor (traction motor)\*

\*: AWD models only

### ■ When stopped/during start off

The gasoline engine stops\* when the vehicle is stopped. During start off, the electric motor (traction motor) drives the vehicle. At slow speeds or when traveling down a gentle slope, the engine is stopped\* and the electric motor (traction

motor) is used.

When the shift lever is in N, the hybrid battery (traction battery) is not being charged.

\*: When the hybrid battery (traction battery) requires charging or the engine is warming up, etc., the gasoline engine will not automatically stop.

(→P.61)

### ■ During normal driving

The gasoline engine is predominantly used. The electric motor (traction motor) charges the hybrid battery (traction battery) as necessary.

### ■ When accelerating sharply

When the accelerator pedal is depressed heavily, the power of the hybrid battery (traction battery) is added to that of the gasoline engine via the electric motor (traction motor).

### ■ When braking (regenerative braking)

The wheels operate the electric motor (traction motor) as a power generator, and the hybrid battery (traction battery) is charged.

### ■ Regenerative braking

In the following situations, kinetic energy is converted to electric energy and deceleration force can be obtained in conjunction with the recharging of the hybrid battery (traction battery).

- The accelerator pedal is released while driving with the shift lever in D or S.
- The brake pedal is depressed while driving with the shift lever in D or S.

### ■ EV indicator

The EV indicator comes on when the vehicle is driven using only the electric motor (traction motor) or the gasoline engine is stopped.

The on/off operation of the EV indicator can be changed. (→P.94)

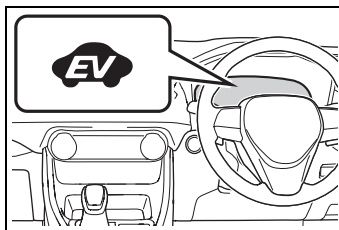

### ■ Conditions in which the gasoline engine may not stop

The gasoline engine starts and stops automatically. However, it may not stop automatically in the following conditions\*:

- During gasoline engine warm-up
- During hybrid battery (traction battery) charging
- When the temperature of the hybrid battery (traction battery) is high or low
- When the heater is switched on

\*: Depending on the circumstances, the gasoline engine may also not stop automatically in other situations.

### ■ Charging the hybrid battery (traction battery)

As the gasoline engine charges the hybrid battery (traction battery), the battery does not need to be charged from an outside source. However, if the vehicle is left parked for a long time the hybrid battery (traction battery) will slowly discharge. For this reason, be sure to drive the vehicle at least once every few months for at least 30 minutes or 16 km (10 miles). If the hybrid battery (traction battery) becomes fully discharged and you are unable to start the hybrid system, contact your Toyota dealer.

### ■ Charging the 12-volt battery

→P.410

### ■ After the 12-volt battery has discharged or when the terminal has been removed and installed during replace, etc.

The gasoline engine may not stop even

if the vehicle is being driven by the hybrid battery (traction battery). If this continues for a few days, contact your Toyota dealer.

#### ■ Sounds and vibrations specific to a Hybrid Electric Vehicle

There may be no engine sound or vibration even though the vehicle is able to move with the "READY" indicator is illuminated. For safety, make sure to shift the shift lever to P and apply the parking brake when parked.

The following sounds or vibrations may occur when the hybrid system is operating and are not a malfunction:

- Motor sounds may be heard from the engine compartment.
- Sounds may be heard from the hybrid battery (traction battery) under the rear seats when the hybrid system starts or stops.
- Relay operating sounds such as a snap or soft clank will be emitted from the hybrid battery (traction battery), under the rear seats, when the hybrid system is started or stopped.
- Sounds from the hybrid system may be heard when the back door is open.
- Sounds may be heard from the transmission when the gasoline engine starts or stops, when driving at low speeds, or during idling.
- Engine sounds may be heard when accelerating sharply.
- Sounds may be heard due to regenerative braking when the brake pedal is depressed or as the accelerator pedal is released.
- Vibration may be felt when the gasoline engine starts or stops.
- Cooling fan sounds may be heard from the air intake vent under the rear seat.

#### ■ Maintenance, repair, recycling, and disposal

Contact your Toyota dealer regarding maintenance, repair, recycling and dis-

posal. Do not dispose of the vehicle yourself.



## Hybrid system precautions

Take care when handling the hybrid system, as it is a high voltage system (about 650V at maximum) as well as contains parts that become extremely hot when the hybrid system is operating. Obey the warning labels attached to the vehicle.

## System components

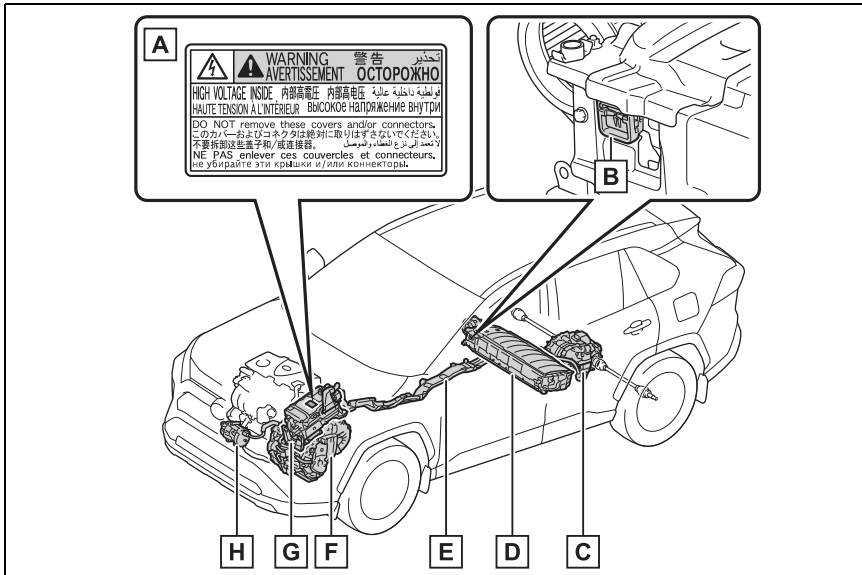

The illustration is an example for explanation and may differ from the actual item.

- A** Warning label
- B** Service plug
- C** Rear electric motor (traction motor)\*
- D** Hybrid battery (traction battery)
- E** High voltage cables (orange)
- F** Front electric motor (traction motor)
- G** Power control unit
- H** Air conditioning compressor

\*: AWD models only

### ■ Running out of fuel

When the vehicle has run out of fuel and the hybrid system cannot be started, refuel the vehicle with at least enough gasoline to make the low fuel level warning light (→P.390) go off. If there is only a small amount of fuel, the hybrid system may not be able to start. (The standard amount of fuel is about 8.8 L [2.3 gal., 1.9 Imp.gal.], when the vehicle is on a level surface. This value may vary when the vehicle is on a slope. Add extra fuel when the vehicle is inclined.)

### ■ Electromagnetic waves

- High voltage parts and cables on Hybrid Electric Vehicles incorporate electromagnetic shielding, and therefore emit approximately the same amount of electromagnetic waves as conventional gasoline powered vehicles or home electronic appliances.
- Your vehicle may cause sound interference in some third party-produced radio parts.

### ■ Hybrid battery (traction battery)

The hybrid battery (traction battery) has a limited service life. The lifespan of the hybrid battery (traction battery) can change in accordance with driving style and driving conditions.



### WARNING

#### ■ High voltage precautions

This vehicle has high voltage DC and AC systems as well as a 12-volt system. DC and AC high voltage is very dangerous and can cause severe burns and electric shock that may result in death or serious injury.

- Never touch, disassemble, remove or replace the high voltage parts, cables or their connectors.

- The hybrid system will become hot after starting as the system uses high voltage. Be careful of both the high voltage and the high temperature, and always obey the warning labels attached to the vehicle.
- Never try to open the service plug access hole located underneath the rear seats. The service plug is used only when the vehicle is serviced and is subject to high voltage.

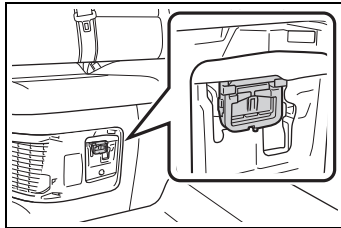

### ■ Road accident cautions

Observe the following precautions to reduce the risk of death or serious injury:

- Pull your vehicle off the road, shift the shift lever to P, apply the parking brake, and turn the hybrid system off.
- Do not touch the high voltage parts, cables and connectors.
- If electric wires are exposed inside or outside your vehicle, an electric shock may occur. Never touch exposed electric wires.
- If a fluid leak occurs, do not touch the fluid as it may be strong alkaline electrolyte from the hybrid battery (traction battery). If it comes into contact with your skin or eyes, wash it off immediately with a large amount of water or, if possible, boric acid solution. Seek immediate medical attention.

**WARNING**

- If a fire occurs in the Hybrid Electric Vehicle, leave the vehicle as soon as possible. Never use a fire extinguisher that is not meant for electric fires. Using even a small amount of water may be dangerous.
- If your vehicle needs to be towed, do so with front wheels (2WD models) or four wheels (AWD models) raised. If the wheels connected to the electric motor (traction motor) are on the ground when towing, the motor may continue to generate electricity. This may cause a fire. (→P.379)
- Carefully inspect the ground under the vehicle. If you find that liquid has leaked onto the ground, the fuel system may have been damaged. Leave the vehicle as soon as possible.

**Hybrid battery (traction battery)**

- Never resell, hand over or modify the hybrid battery. To prevent accidents, hybrid batteries that have been removed from a disposed vehicle are collected through Toyota dealer. Do not dispose of the battery yourself.

Unless the battery is properly collected, the following may occur, resulting in death or serious injury:

- The hybrid battery may be illegally disposed of or dumped, and it is hazardous to the environment or someone may touch a high voltage part, resulting in an electric shock.
- The hybrid battery is intended to be used exclusively with your Hybrid Electric Vehicle. If the hybrid battery is used outside of your vehicle or modified in any way, accidents such as electric shock, heat generation, smoke generation, an explosion and electrolyte leakage may occur.

When reselling or handing over your vehicle, the possibility of an accident is extremely high because the person receiving the vehicle may not be aware of these dangers.

- If your vehicle is disposed of without the hybrid battery having been removed, there is a danger of serious electric shock if high voltage parts, cables and their connectors are touched. In the event that your vehicle must be disposed of, the hybrid battery must be disposed of by your Toyota dealer or a qualified service shop. If the hybrid battery is not disposed of properly, it may cause electric shock that can result in death or serious injury.



## NOTICE

### Hybrid battery (traction battery)

Do not carry large amounts of water such as water cooler bottles in the vehicle.

If water spills onto the hybrid battery (traction battery), the battery may be damaged. Have the vehicle inspected by your Toyota dealer.

### Hybrid battery (traction battery) air intake vent

There is an air intake vent under the right side of the rear seat with the purpose of cooling the hybrid battery (traction battery).

If the vent is blocked, it may interfere with the cooling of the hybrid battery (traction battery). If input/output of the hybrid battery (traction battery) becomes limited and the distance that the vehicle can be driven using the electric motor (traction motor) is reduced, the fuel economy may be reduced.

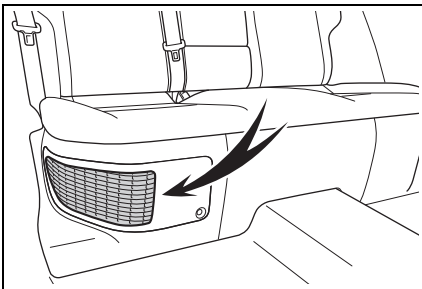

## NOTICE

### Hybrid battery (traction battery) air intake vent

- Make sure not to block the air intake vent with anything, such as a seat cover, luggage, or carpet. The input/output of the hybrid battery (traction battery) may be restricted, leading to a reduction in hybrid battery (traction battery) output and a malfunction.
- Periodically clean the air intake vent to prevent it from clogging. (→P.355)
- Do not get water or foreign materials in the air intake vent as this may cause a short circuit and damage the hybrid battery (traction battery).

### Emergency shut off system

When a certain level of impact is detected by the impact sensor, the emergency shut off system blocks the high voltage current and stops the fuel pump to minimize the risk of electrocution and fuel leakage. If the emergency shut off system activates, your vehicle will not restart. To restart the hybrid system, contact your Toyota dealer.

### Hybrid warning message

A message is automatically displayed when a malfunction occurs in the hybrid system or an improper operation is attempted.

If a warning message is shown on the multi-information display, read the message and follow the instructions.

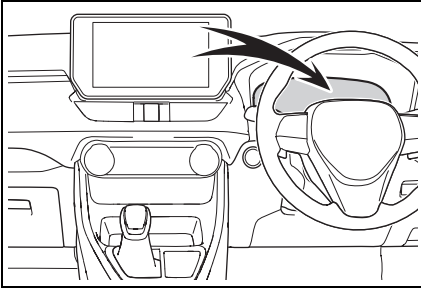

■ **If a warning light comes on, a warning message is displayed, or the 12-volt battery is disconnected**

The hybrid system may not start. In this case, try to start the system again. If the "READY" indicator does not come on, contact your Toyota dealer.

## Immobilizer system

The vehicle's keys have built-in transponder chips that prevent the hybrid system from starting if a key has not been previously registered in the vehicle's on-board computer.

Never leave the keys inside the vehicle when you leave the vehicle.

This system is designed to help prevent vehicle theft but does not guarantee absolute security against all vehicle thefts.

## Operating the system

The indicator light flashes after the power switch has been turned to OFF to indicate that the system is operating.

The indicator light goes off after the power switch has been turned to ACC or ON to indicate that the system has been canceled.

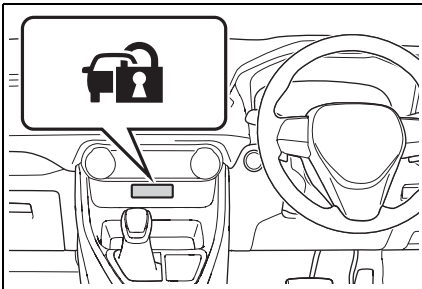

## System maintenance

The vehicle has a maintenance-free type immobilizer system.

## Conditions that may cause the system to malfunction

- If the grip portion of the key is in contact with a metallic object
- If the key is in close proximity to or touching a key to the security system (key with a built-in transponder chip) of another vehicle



## NOTICE

### ■ To ensure the system operates correctly

Do not modify or remove the system. If modified or removed, the proper operation of the system cannot be guaranteed.

## Double locking system\*

\*: If equipped

**Unauthorized access to the vehicle is prevented by disabling the door unlocking function from both the interior and exterior of the vehicle.**

**Vehicles employing this system have labels on the front side windows.**

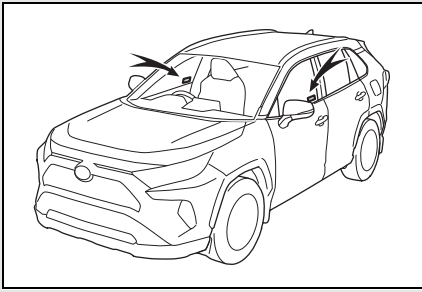

## Setting/canceling the double locking system

### ■ Setting

Turn the power switch to OFF, have all the passengers exit the vehicle and ensure that all the doors are closed.

Using the entry function:  
Touch the sensor area on the front outside door handle twice within 5 seconds.

Using the wireless remote control:  
Press  twice within 5 seconds.

### ■ Canceling

Using the entry function: Hold the front outside door handle.

Using the wireless remote control:

Press  .

### WARNING

#### ■ Double locking system precaution

Never activate the double locking system when there are people in the vehicle because all the doors cannot be opened from inside the vehicle.





## Vehicle status information and indicators

### 2

#### 2-1. Instrument cluster

Warning lights and indicators .....	<b>72</b>
Gauges and meters (with 7- inch display).....	<b>78</b>
Gauges and meters (with 12.3- inch multi-information dis- play).....	<b>83</b>
Multi-information display (with 7-inch display) .....	<b>88</b>
Multi-information display (with 12.3-inch display) .....	<b>98</b>
Energy monitor/consumption screen.....	<b>107</b>

## Warning lights and indicators

The warning lights and indicators on the instrument cluster, center panel and outside rear view mirrors inform the driver of the status of the vehicle's various systems.

### Instrument cluster

For the purpose of explanation, the following illustrations display all warning lights and indicators illuminated.

#### ■ With 7-inch display

The display of the speedometer can be selected from two types, analog or digital. (→P.94)

▶ When analog speedometer is displayed

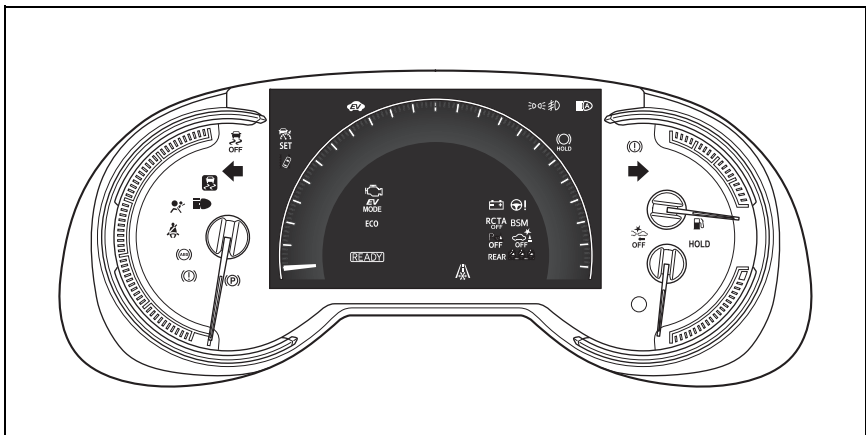

- ▶ When digital speedometer is displayed

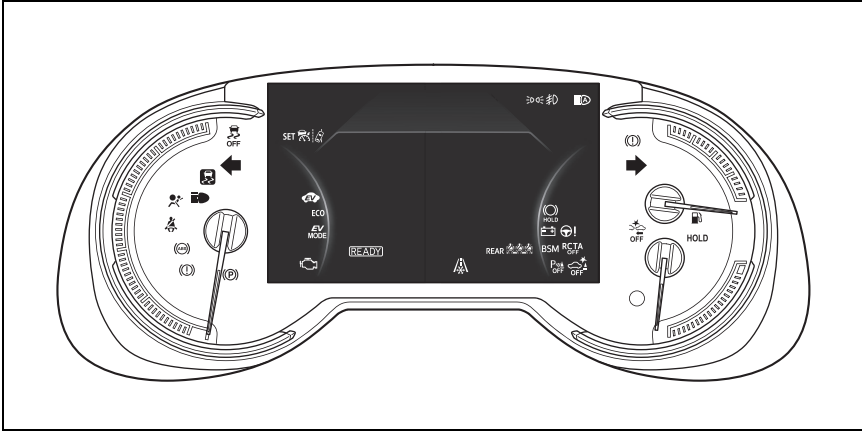

### ■ With 12.3-inch display

The meter type can be changed on  of the multi-information display. (→P.103)

- ▶ Type 1

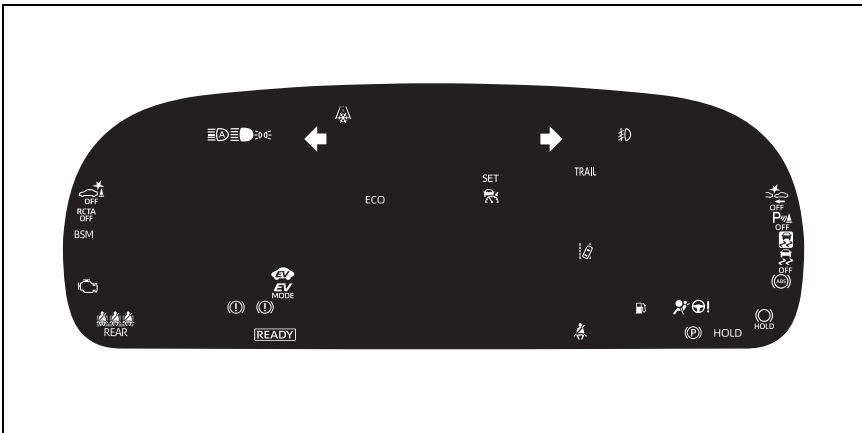

The units used on the meters and some indicators may differ depending on the target region.

## ► Type 2

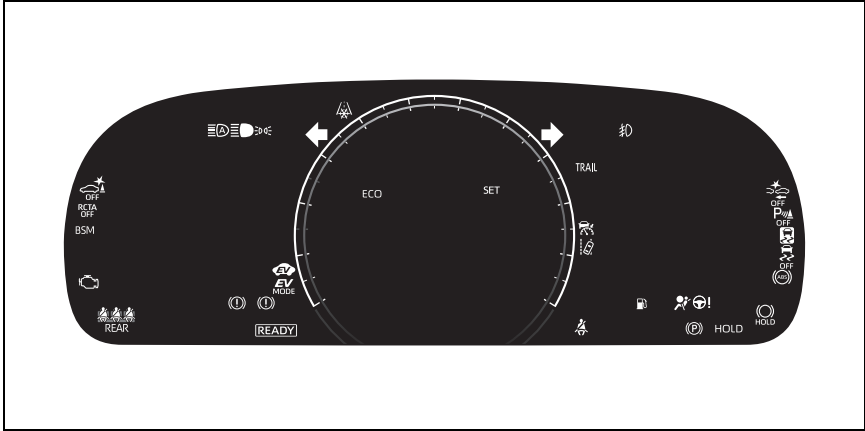

## ► Type 3

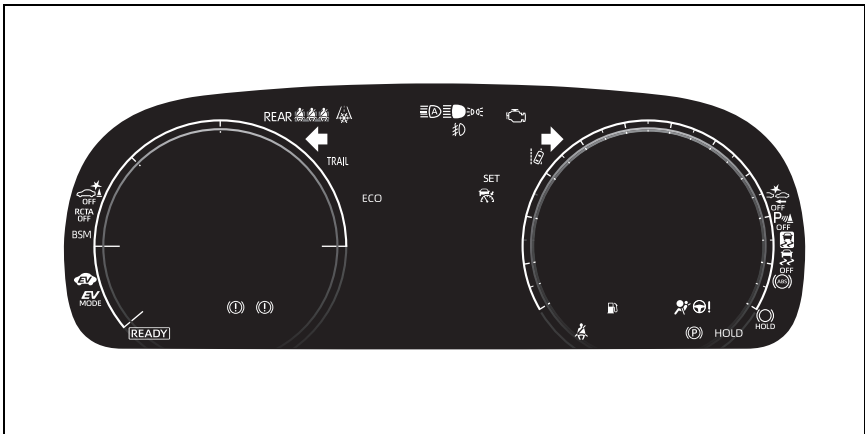

## Warning lights

Warning lights inform the driver of malfunctions in the indicated vehicle's systems.



(Red)

Brake system warning light\*<sup>1</sup>  
(→P.385)



(Yellow)

Brake system warning light\*<sup>1</sup>  
(→P.385)



Charging system warning light (vehicles without 12.3-inch multi-information display)\*<sup>1</sup> (→P.385)



Charging system warning light (vehicles with 12.3-inch multi-information display)\*<sup>2</sup> (→P.385)



High coolant temperature warning light\*<sup>2</sup> (→P.386)



Hybrid system overheating warning light\*<sup>2</sup> (→P.386)



Low engine oil pressure warning light\*<sup>2</sup> (→P.386)



Malfunction indicator lamp\*<sup>1</sup> (→P.386)



SRS warning light\*<sup>1</sup> (→P.387)



ABS warning light\*<sup>1</sup> (→P.387)



Electric power steering system warning light\*<sup>1</sup> (→P.387)  
(Red)



Electric power steering system warning light\*<sup>1</sup> (→P.387)  
(Yellow)



PCS warning light\*<sup>1</sup> (if equipped) (→P.388)  
(Flashes or illuminates)



LTA indicator (if equipped) (→P.388)  
(Orange)



Toyota parking assist-sensor OFF indicator\*<sup>3</sup> (if equipped) (→P.388)  
(Flashes)



PKSB OFF indicator\*<sup>1</sup> (if equipped) (→P.389)  
(Flashes)



RCTA OFF indicator\*<sup>1</sup> (if equipped) (→P.389)  
(Flashes)



Slip indicator light\*<sup>1</sup> (→P.389)



Inappropriate pedal operation warning light\*<sup>2</sup> (→P.390)



Brake hold operated indicator\*<sup>1</sup> (→P.390)  
(Flashes)



Parking brake indicator (→P.390)  
(Flashes)



Low fuel level warning light (→P.390)



Driver's and front passenger's seat belt reminder light (→P.391)



Rear passengers' seat belt reminder lights\*<sup>4</sup> (→P.391)



Rear passengers' seat belt reminder lights (→P.391)

\*<sup>1</sup>: These lights turn on when the power switch is turned to ON to indicate that a system check is being performed. They will turn off after the hybrid system is on, or after a few seconds. There may be a malfunction in a system if the light does not come on, or turn off. Have the vehicle inspected by your Toyota dealer.

\*<sup>2</sup>: This light illuminates on the multi-information display with a message.

\*<sup>3</sup>: Toyota parking assist-sensor OFF indicator turns on when the power switch is turned to ON while the Toyota parking assist-sensor function is on. It will turn off after a few seconds.

\*<sup>4</sup>: Vehicles with 12.3-inch display

**WARNING****■ If a safety system warning light does not come on**

Should a safety system light such as the ABS and SRS warning light not come on when you start the hybrid system, this could mean that these systems are not available to help protect you in an accident, which could result in death or serious injury. Have the vehicle inspected by your Toyota dealer immediately if this occurs.

**Indicators**

The indicators inform the driver of the operating state of the vehicle's various systems.



Turn signal indicator  
(→P.186)



Tail light indicator (→P.193)



Headlight high beam indicator (→P.195)



Automatic High Beam indicator (if equipped) (→P.195)



Fog light indicator (→P.198)



Smart entry & Start system indicator\*<sup>1</sup> (→P.177)



Cruise control indicator (if equipped) (→P.234, 246)



Dynamic radar cruise control indicator (if equipped) (→P.234)



Cruise control "SET" indicator (if equipped) (→P.234, 246)



(White)

LTA indicator\*<sup>2</sup> (if equipped)  
(→P.225)



(Green)

LTA indicator\*<sup>2</sup> (if equipped)  
(→P.210, 226)



(Orange)

LTA indicator\*<sup>2</sup> (if equipped)  
(→P.226)

(Flashes)

Toyota parking assist-sensor OFF indicator\*<sup>3, 4</sup> (if equipped) (→P.254)



PKSB OFF indicator\*<sup>3, 5</sup> (if equipped) (→P.270)



(Flashes)

Slip indicator light\*<sup>5</sup>  
(→P.282)



VSC OFF indicator\*<sup>3, 5</sup>  
(→P.283)



PCS warning light\*<sup>3, 5</sup> (if equipped) (→P.213)



BSM outside rear view mirror indicators\*<sup>5, 6</sup> (if equipped) (→P.249)



BSM indicator (if equipped)  
(→P.249)



RCTA OFF indicator\*<sup>3, 5</sup> (if equipped) (→P.263)



Brake hold standby indicator\*<sup>5</sup> (→P.191)



Brake hold operated indicator\*<sup>5</sup> (→P.191)



Security indicator\*<sup>8</sup> (→P.68)



"READY" indicator  
(→P.177)



Low outside temperature indicator<sup>\*7</sup> (→P.87, 81)



EV indicator (→P.61)



Parking brake indicator (→P.187)



EV drive mode indicator (→P.181)



Eco drive mode indicator (→P.278)



Sport mode indicator (→P.278)



Trail Mode indicator (if equipped) (→P.280)

<sup>\*1</sup>: This light illuminates on the multi-information display with a message.

<sup>\*2</sup>: Depending on the operating condition, the color and illuminating/flash-ing state of the light change.

<sup>\*3</sup>: The light comes on when the system is turned off.

<sup>\*4</sup>: Toyota parking assist-sensor OFF indicator turns on when the power switch is turned to ON while the Toyota parking assist-sensor function is on. It will turn off after a few seconds.

<sup>\*5</sup>: These lights turn on when the power switch is turned to ON to indicate that a system check is being performed. They will turn off after the hybrid system is on, or after a few seconds. There may be a malfunction in a system if the lights do not turn on, or turn off. Have the vehicle inspected by your Toyota dealer.

<sup>\*6</sup>: This light illuminates on the outside rear view mirrors.



<sup>\*7</sup>: When the outside temperature is

approximately 3°C (37°F) or lower, the indicator will flash for approxi-mately 10 seconds, then stay on.

<sup>\*8</sup>: This light illuminates on the center panel.

### ■ BSM (Blind Spot Monitor) outside rear view mirror indicators (if equipped)

In order to confirm operation, the BSM outside rear view mirror indicators illuminate in the following situations:

- When the power switch is turned to ON while the BSM function is enabled on the  screen of the multi-infor-mation display.
- When the BSM function is enabled on the  screen of the multi-information display while the power switch is in ON.

If the system is functioning correctly, the BSM outside rear view mirror indicators will turn off after a few seconds.

If the BSM outside rear view mirror indi-cators do not illuminate or do not turn off, there may be a malfunction in the system. If this occurs, have the vehicle inspected by your Toyota dealer.

## Gauges and meters (with 7-inch display)

The meters display various drive information.

### Meter display

The display of the speedometer can be selected from two types, analog or digital. (→P.94)

#### ▶ Analog speedometer

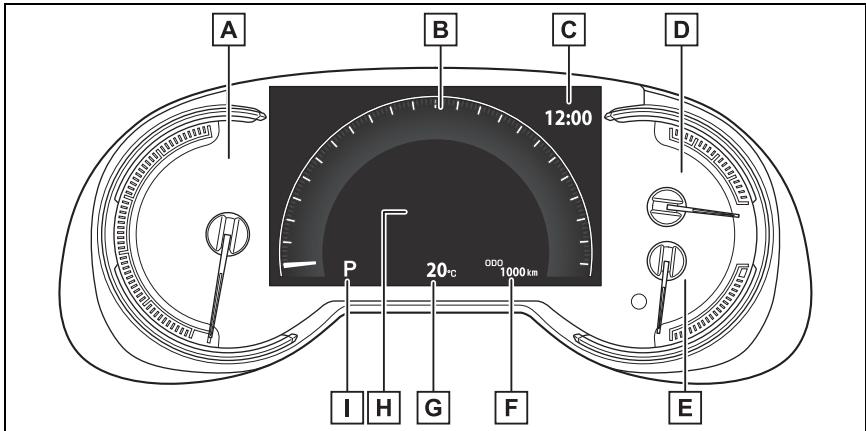

#### **A** Hybrid System Indicator

Displays the Hybrid System Indicator (→P.81)

#### **B** Speedometer

Displays the vehicle speed

#### **C** Clock

Automatically adjusts the time by using the GPS time information (GPS clock).  
For details, refer to “Multimedia Owner’s Manual”.

#### **D** Fuel gauge

Displays the quantity of fuel remaining in the tank.

In the following situations, the actual quantity of fuel remaining in the tank may not be displayed correctly. Refer to P.81 if the actual quantity of fuel remaining in the tank is not displayed correctly.

- A small amount of fuel is added.
- Fuel is added with the fuel gauge near or at “F”.
- The vehicle is stopped on an uneven surface, such as a slope.



- The vehicle is driven on a slope or around a curve.

### **E** Engine coolant temperature gauge

Displays the engine coolant temperature

### **F** Odometer, trip meter and instrument cluster light control display

Odometer:

Displays the total distance that the vehicle has been driven

Trip meter:

Displays the distance the vehicle has been driven since the meter was last reset.

Trip meters "A" and "B" can be used to record and display different distances independently.

Instrument cluster light control:

Displays the brightness of the instrument cluster lights that can be adjusted.

### **G** Outside temperature (→P.81)

### **H** Multi-information display

Presents the driver with a variety of driving-related data (→P.88)

Displays warning messages if a malfunction occurs (→P.392)

### **I** Shift position and shift range indicator

Displays the selected shift position or selected shift range (→P.183)

### ► Digital speedometer

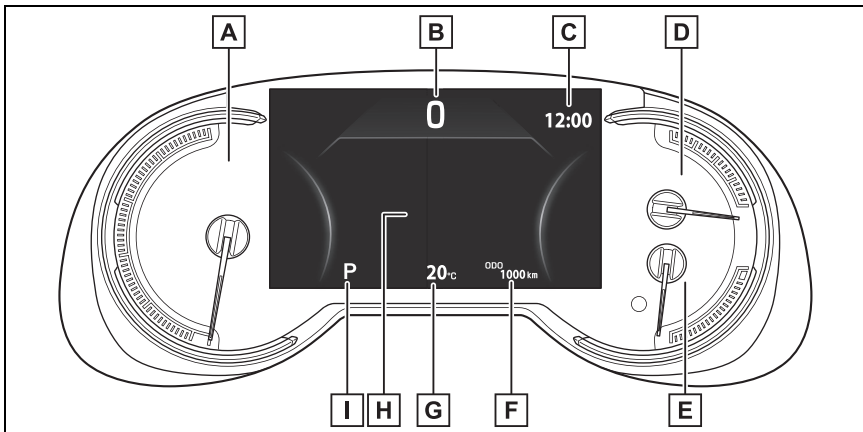

### **A** Hybrid System Indicator

Displays the Hybrid System Indicator (→P.81)

### **B** Speedometer

Displays the vehicle speed

**C** Clock

Automatically adjusts the time by using the GPS time information (GPS clock).  
For details, refer to “Multimedia Owner’s Manual”.

**D** Fuel gauge

Displays the quantity of fuel remaining in the tank.

In the following situations, the actual quantity of fuel remaining in the tank may not be displayed correctly. Refer to P.81 if the actual quantity of fuel remaining in the tank is not displayed correctly.

- A small amount of fuel is added.
- Fuel is added with the fuel gauge near or at “F”.
- The vehicle is stopped on an uneven surface, such as a slope.
- The vehicle is driven on a slope or around a curve.

**E** Engine coolant temperature gauge

Displays the engine coolant temperature

**F** Odometer, trip meter and instrument cluster light control display

Odometer:

Displays the total distance that the vehicle has been driven

Trip meter:

Displays the distance the vehicle has been driven since the meter was last reset.

Trip meters “A” and “B” can be used to record and display different distances independently.

Instrument cluster light control:

Displays the brightness of the instrument cluster lights that can be adjusted.

**G** Outside temperature (→P.81)**H** Multi-information display

Presents the driver with a variety of driving-related data (→P.88)

Displays warning messages if a malfunction occurs (→P.392)

**I** Shift position and shift range indicator

Displays the selected shift position or selected shift range (→P.183)

---

**■ The meters and display illuminate when**

The power switch is in ON.

**■ When changing driving mode**

- Speedometer color is changed following the selected driving mode. (→P.278)

- AWD models: Speedometer color is changed following the selected driving mode or when Trail Mode is turned on. (→P.278, 280)

## ■ Hybrid System Indicator

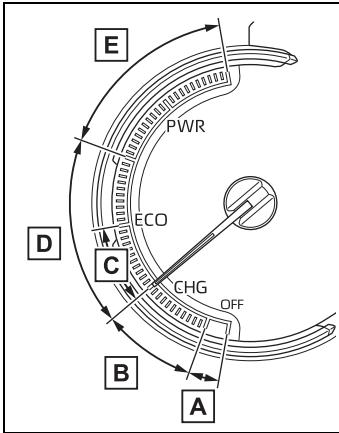

### **A** READY OFF area

Shows that the hybrid system is not operating.

### **B** Charge area

Shows regeneration\* status. Regenerated energy will be used to charge the hybrid battery (traction battery).

### **C** Hybrid Eco area

Shows that gasoline engine power is not being used very often.

The gasoline engine will automatically stop and restart under various conditions.

### **D** Eco area

Shows that the vehicle is being driven in an Eco-friendly manner.

By keeping the indicator needle within Eco area, more Eco-friendly driving can be achieved.

### **E** Power area

Shows that an Eco-friendly driving range is being exceeded (during full power driving etc.)

\*: When used in this manual, “regeneration” refers to the conversion of energy created by the movement of the vehicle into electrical energy.

In the following situation, the Hybrid System Indicator does not operate.

- “READY” indicator is not illuminated.
- The shift lever is in a range other than D or S.

## ■ Manually updating the fuel gauge and possible driving range

The fuel gauge and the possible driving range are linked. If the displays of the fuel gauge and possible driving range do not update after adding a small amount of fuel, the displays can be updated by performing the following procedure.

- 1 Stop the vehicle on a level surface.
- 2 Press the “ODO TRIP” switch to change the odometer and trip meter display to odometer.
- 3 Turn the power switch off.
- 4 While pressing and holding the “ODO TRIP” switch, turn the power switch to ON.
- 5 Continue to hold the “ODO TRIP” switch for approximately 5 seconds, and then release it once the odometer begins flashing.

Updating is complete once the odometer flashes for approximately 5 seconds and then the display returns to normal.

## ■ Outside temperature display

- In the following situations, the correct outside temperature may not be displayed, or the display may take longer than normal to change.
  - When stopped, or driving at low speeds (less than 20 km/h [12 mph])
  - When the outside temperature has changed suddenly (at the entrance/exit of a garage, tunnel, etc.)
- When “--” or “E” is displayed, the system may be malfunctioning. Take your vehicle to your Toyota dealer.

- Displays the outside temperature within the range of  $-40^{\circ}\text{C}$  ( $-40^{\circ}\text{F}$ ) to  $50^{\circ}\text{C}$  ( $122^{\circ}\text{F}$ ).
- When the outside temperature is approximately  $3^{\circ}\text{C}$  ( $37^{\circ}\text{F}$ ) or lower, the indicator  will flash for approximately 10 seconds, then stay on.

### ■ Liquid crystal display

→P.89

### ■ Customization

Settings (e. g. meter display) can be changed on the  screen of the multi-information display. (→P.94)



### WARNING

#### ■ The information display at low temperatures

Allow the interior of the vehicle to warm up before using the liquid crystal information display. At extremely low temperatures, the display monitor may respond slowly, and display changes may be delayed.

For example, there is a lag between the driver's shifting and the new shift range appearing on the display. This lag could cause the driver to down-shift again, causing rapid and excessive engine braking and possibly an accident resulting in death or injury.



### NOTICE

#### ■ To prevent damage to the engine and its components

The engine may be overheating if the engine coolant temperature gauge is in the red zone ("H"). In this case, immediately stop the vehicle in a safe place, and check the engine after it has cooled completely. (→P.413)

## Using the "ODO TRIP" switch

Switches the items of the odometer, trip meter A, trip meter B and the brightness of the instrument cluster lights by pressing the "ODO TRIP" switch.

- When the trip meter is displayed, pressing and holding the switch will reset the trip meter.
- When the instrument cluster light control display is displayed, pressing and holding the switch will adjust the brightness of the instrument cluster lights.

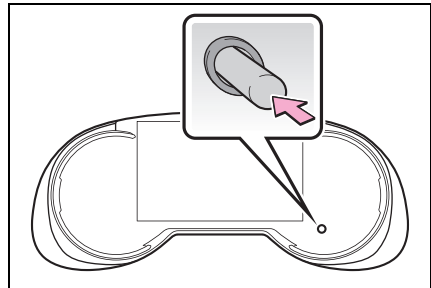

### ■ Instrument cluster brightness adjustment

The instrument cluster brightness levels when the tail lights are on and off can be adjusted individually. However, when the surroundings are bright (daytime, etc.), turning on the tail lights will not change the instrument cluster brightness.

## Gauges and meters (with 12.3-inch multi-information display)

The meters display various drive information.

### Meter display

#### ■ Locations of gauges and meters

The meter type can be changed on  of the multi-information display. (→P.103)

#### ▶ Type 1/Type 2

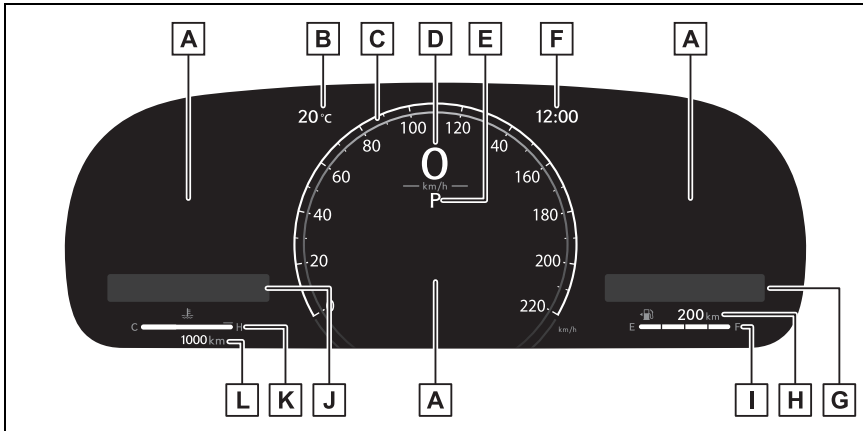

The units of measure may differ depending on the intended destination of the vehicle.

#### **A** Multi-information display

Presents the driver with a variety of vehicle data (→P.98)  
Displays warning messages if a malfunction occurs (→P.392)

#### **B** Outside temperature (→P.87)

#### **C** Analog meter (Type 2 only)

The dial type of analog meter can be changed on  of the multi-information display. (→P.103)

Analog speedometer:

Displays the vehicle speed.

Hybrid System Indicator:

Displays the Hybrid System Indicator. (→P.86)

**D** Digital speedometer

Displays the vehicle speed

**E** Shift position and shift range

Displays the selected shift position or selected shift range (→P.90)

**F** Clock

Automatically adjusts the time by using the GPS time information (GPS clock).

For details, refer to “Multimedia Owner’s Manual”.

**G** Widget (Audio system-linked display)

Displays the selected audio source or track on the meter. (→P.102)

While list of items for content display area (→P.100) is displayed, widget will not be displayed.

**H** Distance to empty

Displays driving range with remaining fuel. (→P.86)

**I** Fuel gauge

Displays the quantity of fuel remaining in the tank.

In the following situations, the actual quantity of fuel remaining in the tank may not be displayed correctly. Refer to P.87 if the actual quantity of fuel remaining in the tank is not displayed correctly.

- A small amount of fuel is added.
- Fuel is added with the fuel gauge near or at “F”.
- The vehicle is stopped on an uneven surface, such as a slope.
- The vehicle is driven on a slope or around a curve.

**J** Widget (Fuel Economy)

Displays fuel economy information. (→P.100)

While list of items for content display area (→P.100) is displayed, widget will not be displayed.

**K** Engine coolant temperature gauge

Displays the engine coolant temperature

**L** Odometer and trip meter display (→P.88)

## ► Type 3

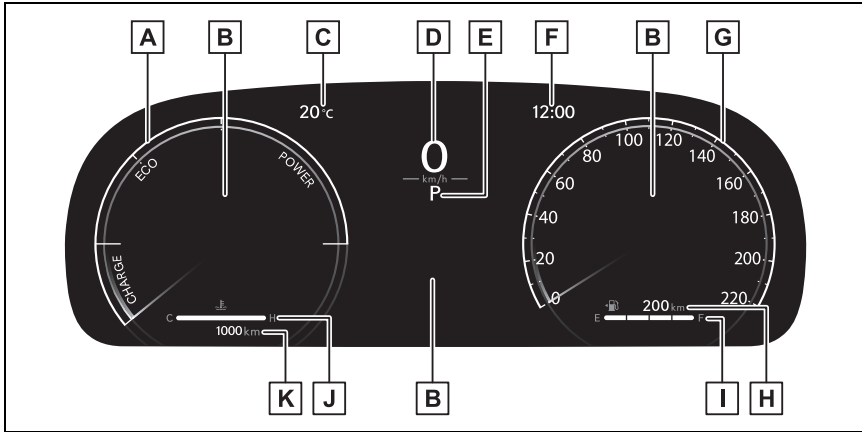
**A** Hybrid System Indicator

Displays the Hybrid System Indicator. (→P.86)

**B** Multi-information display

Presents the driver with a variety of vehicle data (→P.103)

Displays warning messages if a malfunction occurs (→P.396)

**C** Outside temperature (→P.87)**D** Digital speedometer

Displays the vehicle speed

**E** Shift position and shift range

Displays the selected shift position or selected shift range (→P.186)

**F** Clock

Automatically adjusts the time by using the GPS time information (GPS clock).

For details, refer to “Multimedia Owner’s Manual”.

**G** Analog speedometer

Displays the vehicle speed.

**H** Distance to empty

Displays driving range with remaining fuel. (→P.86)

**I** Fuel gauge

Displays the quantity of fuel remaining in the tank.

In the following situations, the actual quantity of fuel remaining in the tank may not be displayed correctly. Refer to P.87 if the actual quantity of fuel remaining in the

tank is not displayed correctly.

- A small amount of fuel is added.
- Fuel is added with the fuel gauge near or at "F".
- The vehicle is stopped on an uneven surface, such as a slope.
- The vehicle is driven on a slope or around a curve.

### **J** Engine coolant temperature gauge

Displays the engine coolant temperature

### **K** Odometer and trip meter display (→P.88)

#### ■ The meters and display illuminate when

The power switch is in ON.

#### ■ Engine speed

On hybrid vehicles, engine speed is precisely controlled in order to help improve fuel efficiency and reduce exhaust emissions etc.

There are times when the engine speed that is displayed may differ even when vehicle operation and driving conditions are the same.

#### ■ Hybrid System Indicator

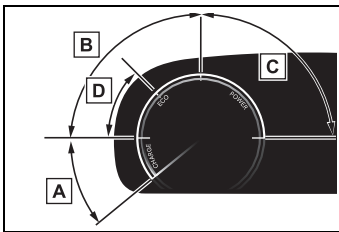

#### **A** Charge area

Shows regeneration\* status.

Regenerated energy will be used to charge the hybrid battery (traction battery).

#### **B** Eco area

Shows that the vehicle is being driven in an Eco-friendly manner.

By keeping the bar display within Eco area, more Eco-friendly driving can be

achieved.

#### **C** Power area

Shows that an Eco-friendly driving range is being exceeded (during full power driving etc.)

#### **D** Hybrid Eco area

Shows that gasoline engine power is not being used very often.

The gasoline engine will automatically stop and restart under various conditions.

\*: When used in this manual, regeneration refers to the conversion of energy created by the movement of the vehicle into electrical energy.

#### ■ Hybrid System Indicator is displayed when

The Hybrid System Indicator is displayed in the following situations:

- The shift position is in D or S.
- The hybrid system is started.

#### ■ Distance to empty

- This distance is computed based on your average fuel consumption. As a result, the actual distance that can be driven may differ from that displayed.
- When only a small amount of fuel is added to the tank, the display may not be updated. When refueling, turn the power switch off. If the vehicle is refueled without turning the power switch off, the display may not be updated.



- When “Refuel” is displayed, the remaining fuel amount is low and the distance that can be driven with the remaining fuel cannot be calculated. Refuel immediately.

### ■ Manually updating the fuel gauge and possible driving range

The fuel gauge and the possible driving range are linked. If the displays of the fuel gauge and possible driving range do not update after adding a small amount of fuel, the displays can be updated by performing the following procedure.

- 1 Stop the vehicle on a level surface.
- 2 Press the “ODO TRIP” switch to change the odometer and trip meter display to odometer.
- 3 Turn the power switch off.
- 4 While pressing and holding the “ODO TRIP” switch, turn the power switch to ON.
- 5 Continue to hold the “ODO TRIP” switch for approximately 5 seconds, and then release it once the odometer begins flashing.

Updating is complete once the odometer flashes for approximately 5 seconds and then the display returns to normal.

### ■ Outside temperature display

- Displays the outside temperature within the range of -40°C (-40°F) to 50°C (122°F).
- When the outside temperature is approximately 3°C (37°F) or lower, the indicator  will flash for approximately 10 seconds, then stay on.
- In the following situations, the correct outside temperature may not be displayed, or the display may take longer than normal to change:
  - When stopped, or driving at low speeds (less than 20 km/h [12 mph])
  - When the outside temperature has changed suddenly (at the entrance/exit of a garage, tunnel, etc.)
- When “--” or “E” is displayed, the sys-

tem may be malfunctioning. Take your vehicle to your Toyota dealer.

### ■ Free/Open Source Software Information

This product contains Free/Open Source Software (FOSS). The license information and/or the source code of such FOSS can be found at the following URL.

<https://www.denso.com/global/en/opensource/meter/toyota/>

### ■ Liquid crystal display

→P.98

### ■ Customization

The gauges and meters can be customized on  of the multi-information display. (→P.103)



### WARNING

#### ■ The information display at low temperatures

Allow the interior of the vehicle to warm up before using the liquid crystal information display. At extremely low temperatures, the information display monitor may respond slowly, and display changes may be delayed.

For example, there is a lag between the driver's shifting and the new gear number appearing on the display. This lag could cause the driver to downshift again, causing rapid and excessive engine braking and possibly an accident resulting in death or injury.



## NOTICE

■ **To prevent damage to the engine and its components**

The engine may be overheating if the engine coolant temperature gauge is in the red zone (H). In this case, immediately stop the vehicle in a safe place, and check the engine after it has cooled completely. (→P.413)

## Odometer and trip meter display

### ■ Display items

#### ● Odometer

Displays the total distance the vehicle has been driven.

#### ● Trip meter A/trip meter B

Displays the distance the vehicle has been driven since the meter was last reset. Trip meters A and B can be used to record and display different distances independently.

### ■ Changing the display

Each time the “ODO TRIP” switch is pressed, the displayed item will be changed. When the trip meter is displayed, pressing and holding the switch will reset the trip meter.

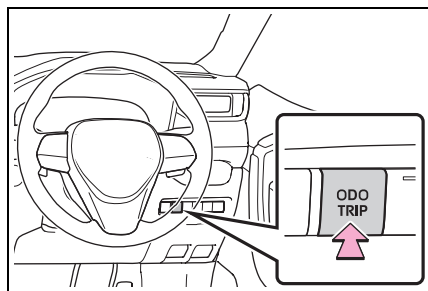

## Multi-information display (with 7-inch display)

The multi-information display is used to display fuel efficiency related information and various types of driving-related information. The multi-information display can also be used to change the display settings and other settings.

### Display contents

Following information is displayed on the multi-information display.

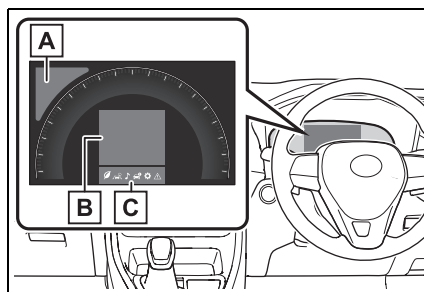

#### A Driving support system information

Displays a sign when the RSA system (if equipped) is operating and recognizes the sign. (→P.231)

Displays an image when the following systems are operating and a menu icon

other than  is selected:

- LTA (Lane Tracing Assist) (if equipped) (→P.220)
- Dynamic radar cruise control with full-speed range (if equipped) (→P.234)
- Cruise control (if equipped) (→P.246)

#### B Information display area

A variety of information can be displayed by selecting a menu icon.

Additionally, warning or suggestion/advice pop-up displays will be displayed in some situations.

**C** Menu icons (→P.90)

### ■ The multi-information display is displayed when

The power switch is in ON.

### ■ When changing driving mode

- Background color of the multi-information display is changed following the selected driving mode. (→P.278)
- AWD models: Background color of the multi-information display is changed following the selected driving mode or when Trail Mode is turned on. (→P.278, 280)

### ■ Liquid crystal display

Small spots or light spots may appear on the display. This phenomenon is characteristic of liquid crystal displays, and there is no problem continuing to use the display.



### WARNING

#### ■ Caution for use while driving

- When operating the multi-information display while driving, pay extra attention to the safety of the area around the vehicle.
- Do not look continuously at the multi-information display while driving as you may fail to see pedestrians, objects on the road, etc. ahead of the vehicle.

#### ■ The information display at low temperatures

→P.81

## Changing the display

The multi-information display is operated using the meter control switches.

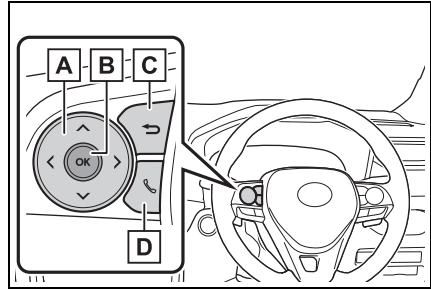

- A** Scroll the screen<sup>\*</sup>/switch the display<sup>\*</sup>/move the cursor
- B** Press: Enter/Set  
Press and hold: Reset/Display customizable items
- C** Return to the previous screen
- D** Call sending/receiving and history display (if equipped)  
Linked with the hands-free system, sending or receiving call is displayed. For details regarding the hands-free system, refer to "Multimedia Owner's Manual".

<sup>\*</sup>: On screens where the screen can be scrolled and the display can be switched, a scroll bar or a round icon that shows the number of registered screens is displayed.

**WARNING****Caution for use while driving**

For safety, avoid operating the meter control switches while driving as much as possible, and do not look continuously at the multi-information display while driving. Stop the vehicle and operate the meter control switches. Failure to do so may cause a steering wheel operation error, resulting in an unexpected accident.

**Menu icons**

Information related to each icon can be displayed by selecting the icon with the meter control switches.

Some of the information may be displayed automatically depending on the situation.

Icon	Display
	Driving information display (→P.90)
	Driving support system information display (→P.92)
	Audio system-linked display (→P.93)
	Vehicle information display (→P.93)
	Settings display (→P.94)
	Warning message display (→P.97)

**Driving information display**

Select to display fuel consumption

data in various forms.

**Fuel Economy**

Following information is displayed.

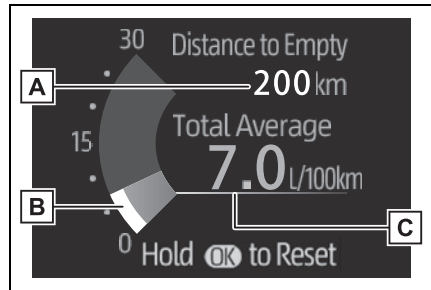
**A** Distance to empty

Displays the driving range with remaining fuel. (→P.92)

**B** Current fuel economy

Displays the instantaneous current fuel Economy.

**C** Average fuel economy

Displays the average fuel economy since the function was reset or the average fuel economy after starting or refueling.\*1, 2, 3

The average fuel economy selected by “Fuel Economy” on the screen is displayed. (→P.94)

\*1: Use the displayed fuel consumption as a reference only.

\*2: Average fuel economy since the function was reset can be reset by pressing and holding .

\*3: Average fuel economy after starting is reset each time the hybrid system stops.

**ECO Accelerator Guidance**“Eco Score”

Displays a reference operation

range for using the accelerator pedal according to driving conditions, and a score result that evaluates the current driving status.

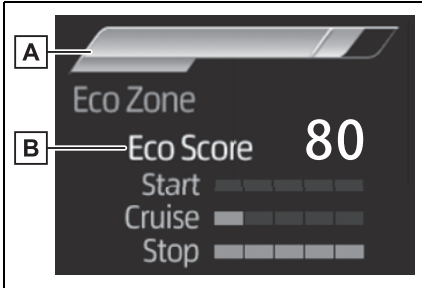

**A** ECO Accelerator Guidance

**B** “Eco Score”

► ECO Accelerator Guidance

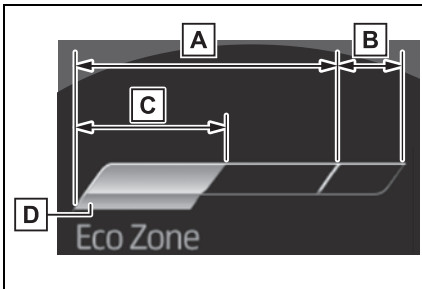

**A** ECO area

Shows that the vehicle is being driven in an Eco-friendly manner.

**B** Power area

Shows that an Eco-friendly driving range is being exceeded (during full power driving etc.).

**C** Current acceleration

**D** Reference operation range

A zone is displayed in blue under the Eco area which can be used as a reference operation range for using the

accelerator pedal according to driving conditions such as starting off and cruising.

The ECO Accelerator Guidance display changes according to the driving status, such as when starting off or cruising.

It is easier to drive in an Eco-friendly manner by driving according to the display showing the accelerator pedal operations and staying within the reference operation range.

► “Eco Score”

The driving status for the following 3 situations are evaluated in 5 levels: Smooth start-off acceleration (“Start”), driving without sudden acceleration (“Cruise”) and smooth stopping (“Stop”). Each time the vehicle is stopped, a score result is displayed out of a perfect score of 100 points.

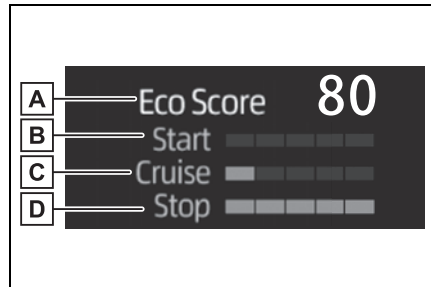

**A** Score result

**B** “Start”

**C** “Cruise”

**D** “Stop”

3 situations are displayed with each icon while driving.

How to read the bar display:

Score	Bar display
Unrated	
Low	
High	

After starting off, “Eco Score” display does not start until the vehicle speed exceeds approximately 30km/h (19mph).

The “Eco Score” is reset each time the vehicle starts off to start a new evaluation.

When the hybrid system stops, the current total score result is displayed.\*

\*: The score result is displayed only when “Eco Score” is selected for “Trip Summary”. (→P.94)

### ■ EV Ratio/EV Driving Ratio

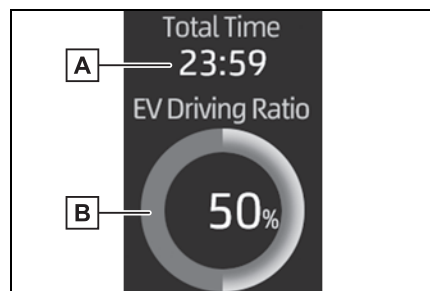

**A** Elapsed time after starting

Displays the elapsed time since hybrid system was started.\*

**B** EV driving ratio after starting

Displays the percentage of EV driving since the hybrid system was started.\*

\*: It is reset each time the hybrid system stops.

### ■ Distance to empty

- This distance is computed based on your average fuel consumption. As a result, the actual distance that can be driven may differ from that displayed.
- When only a small amount of fuel is added to the tank, the display may not be updated. When refueling, turn the power switch to OFF. If the vehicle is refueled without turning the power switch to OFF, the display may not be updated.
- When “Refuel” is displayed, the remaining fuel amount is low and the distance that can be driven with the remaining fuel cannot be calculated. Refuel immediately.

### ■ ECO Accelerator Guidance/“Eco Score” will not operate when

The ECO Accelerator Guidance/“Eco Score” will not operate in the following situations:

- The Hybrid System Indicator is not operating.
- The vehicle is being driven using the dynamic radar cruise control with full-speed range.

## Driving support system information display

### ■ Driving support system information display

Select to display the operational status of the following systems:

- LTA (Lane Tracing Assist)\* (→P.220)
- RSA (Road Sign Assist)\* (→P.231)
- Dynamic radar cruise control with full-speed range\* (→P.234)
- Cruise control\* (→P.246)

\*: If equipped

### Navigation system-linked display (if equipped)

Select to display the following navigation system-linked information.

- Route guidance
- Compass display

### Audio system-linked display

Select to enable selection of an audio source or track on the display.

### Vehicle information display

#### ■ Drive information

2 items that are selected using the “Drive Info Items” setting (average speed, distance and total time) can be displayed vertically.

The displayed information changes according to the “Drive Info Type” setting (since the system was started or between resets).

(→P.94)

Use the displayed information as a reference only.

Following items will be displayed.

- “Trip”
- “Average Speed”: Displays the average vehicle speed since hybrid system start\*
- “Distance”: Displays the distance driven since hybrid system start\*
- “Total Time”: Displays the elapsed

time since hybrid system start\*

\*: These items are reset each time the hybrid system stops.

- “Total”
- “Average Speed”: Displays the average vehicle speed since the display was reset\*
- “Distance”: Displays the distance driven since the display was reset\*
- “Total Time”: Displays the elapsed time since the display was reset\*

\*: To reset, display the desired item and press and hold .

#### ■ Energy monitor

→P.107

#### ■ AWD system display (AWD models)

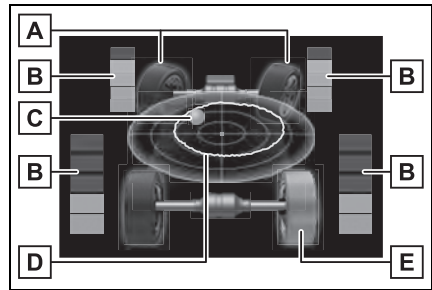

#### **A** Front tire direction display

Displays the operation amount and direction of the steering wheel via changes to the front tires on the display.

#### **B** Torque distribution display

Displays the drive status of each wheel in 6 steps from 0 to 5.

#### **C** G-force display\*

Displays the size and direction of the G-force applied to the vehicle via changes

to the position of the ball on the display.

#### **D** Maximum G-force course\*

This item is linked with the G-force display and the course of the past movement of the ball is displayed.

Press and hold  to reset the record.

#### **E** Wheel spin display

When a tire is spinning, its icon on the display changes its color and blinks.







\*: This item is displayed only when driving mode is set to sport mode.



The illustration used is intended as an example, and may differ from the image that is actually displayed on the multi-information display.

## Settings display

Vehicle settings and the content displayed on the screen can be changed by using the meter control switches.

### ■ Setting procedure

- 1 Operate  or  of the meter control switches and select .
- 2 Operate  or  of the meter control switches and select the desired item.
  - If the function is turned on and off or the volume, etc. is changed on the setting screen, the setting is changed each time  is pressed.
  - For functions that allow operation contents, display contents, etc., to be selected, the setting

screen is displayed by pressing and holding . When the setting screen is displayed, select the setting or desired value (time, etc.) with .

- 3 After changing the settings, press  of the meter control switches.

### ■ LTA (Lane Tracing Assist) (if equipped) (→P.220)

Select to set up the following items.

- “Lane Centre”  
Select to enable/disable the lane centering function.
- “Sensitivity”  
Select to set the lane departure alert sensitivity.
- “Sway Warning”  
Select to enable/disable the vehicle sway warning.
- “Sway Sensitivity”  
Select to set the vehicle sway warning sensitivity.

### ■ PCS (Pre-Collision System) (if equipped) (→P.210)

Select to set up the following items.

- PCS on/off  
Select to enable/disable the pre-collision system.
- “Sensitivity”  
Select to change the pre-collision warning timing.



### ■ **BSM (Blind Spot Monitor)** (if equipped) (→P.249)

Select to set up the following items.

- **BSM (Blind Spot Monitor) on/off**

Select to enable/disable the BSM system.

- **“Brightness”**

Select to switch the brightness of the outside rear view mirror indicators.  
(→P.249)

- **“Sensitivity”**

Select to change the alert timing for an approaching vehicle.

### ■ **(Toyota parking assist-sensor)** (if equipped) (→P.253)

Select to set up the following items.

- **Toyota parking assist-sensor on/off**

Select to enable/disable the Toyota parking assist-sensor.

- **“Volume”**

Select to set the volume of the buzzer which sounds when the Toyota parking assist-sensor is operated.

### ■ **RCTA (Rear Cross Traffic Alert)** (if equipped) (→P.263)

- **RCTA (Rear Cross Traffic Alert) on/off**

Select to enable/disable the RCTA system.

- **“Volume”**

Select to change the RCTA buzzer volume.

### ■ **PKSB (Parking Support Brake System)** (if equipped) (→P.268)

Select to enable/disable the Parking Support Brake function.

### ■ **RSA (Road Sign Assist)** (if equipped) (→P.231)

Select to set up the following items.

- **Road Sign Assist on/off**

Select to enable/disable the RSA system.

- **“Notification method”**

Select to change each notification method used to notify the driver when the system recognizes excess speed.

- **“Notification Level”**

Select to change each notification level used to notify the driver when the system recognizes a speed limit sign.

### ■ **DRCC (RSA) (if equipped)** (→P.242)

Select to enable/disable the Dynamic Radar Cruise Control with Road Sign Assist.

### ■ **Vehicle Settings**

-  **PBD (Power Back Door)** (if equipped) (→P.123)

Select to set up the following items.

- **System settings**

Select to enable/disable the power back door system.

- **“Opening Adjustment”**

Select the open position when power back door is fully open.

- **“Volume”**

Select to set the volume of the buzzer which sounds when the power back door system operates.

- “Rear Seat Reminder” (→P.117)

Select to enable/disable the rear seat reminder function.

## ■ Settings

- “Language”

Select to change the language on the multi-information display.

- “Units”

Select to change the unit of measure for fuel consumption.

- “Meter Type”

Select to change the speedometer display.

-  (EV indicator) (→P.61)

Select to enable/disable the EV indicator.

-  (Driving information cluster display settings)

Select to set up the following items.

- “Hybrid System”

Select to enable/disable the ECO Accelerator Guidance (→P.90).

- “Fuel Economy”

Select to change the display on Fuel Economy (→P.90).

-  (Audio settings)

Select to enable/disable  screen.

-  (Vehicle information display settings)

- “Display Contents”

Select to set up the following items.

“Energy monitor”:

Select to enable/disable the Energy monitor (→P.107)

AWD (AWD models):

Select to enable/disable the AWD system display (→P.93).

- “Drive Info Type”

Select to change the drive information type display between trip and total. (→P.93).

- “Drive Info Items”

Select to set the items on the upper and lower side of the drive information screen from three items, average speed, distance and total time.

- “Trip Summary”

Select to set the items displayed when the power switch is turned off.

- “Pop-Up Display”

Select to enable/disable the following pop-up displays, which may appear in some situations.

- Intersection guidance display of the navigation system-linked system
- Incoming call display of the hands-free phone system
- Audio operation
- Volume operation
- Voice control
- “MID OFF”

A blank screen is displayed

- “Default Settings”

Select to reset the meter display settings.

## ■ Suspension of the settings display

- In the following situations, operation of the settings display will be temporarily suspended.
- When a warning message appears on the multi-information display

- When the vehicle begins to move
- Settings for functions not equipped to the vehicle are not displayed.
- When a function is turned off, the related settings for that function are not selectable.

**WARNING**

■ **Cautions during setting up the display**

As the hybrid system needs to be operating during setting up the display, ensure that the vehicle is parked in a place with adequate ventilation. In a closed area such as a garage, exhaust gases including harmful carbon monoxide (CO) may collect and enter the vehicle. This may lead to death or a serious health hazard.

**NOTICE**

■ **During setting up the display**

To prevent 12-volt battery discharge, ensure that the hybrid system is operating while setting up the display features.

### Warning message display

Select to display warning messages and measures to be taken if a malfunction is detected.

(→P.392)

### Convenience Services (Suggestion function)

Displays suggestions to the driver in the following situations. To select a response to a displayed suggestion, use the meter control switches.

#### ■ Suggestion to turn off the headlights

If the headlights are left on for a certain amount of time after the power switch has been turned off, a suggestion message will be displayed.

When the headlight switch is in the AUTO position:

The message asking if you wish to turn the headlights off is displayed. To turn the headlights off, select “Yes”.

If the driver’s door is opened after the power switch is turned off, this suggestion message will not be displayed.

#### ■ Suggestion to close the power windows (linked to windshield wiper operation)

If the windshield wipers are operated with a power window open, a suggestion message will be displayed asking if you wish to close the power windows. To close all of the power windows, select “Yes”.

#### ■ Customization

Convenience Services (Suggestion function) can be turned on/off. (Customizable features: →P.430)

## Multi-information display (with 12.3-inch display)

The multi-information display is used to display fuel efficiency related information and various types of driving-related information. The multi-information display can also be used to change the display settings and other settings.

### Display contents

Following information is displayed in each area on the multi-information display.

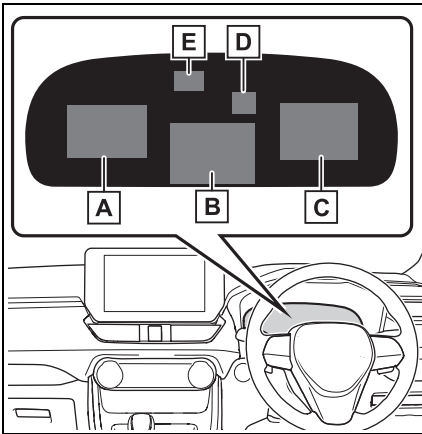

- A** Content display area (left)
- B** Content display area (center)
- C** Content display area (right)
- D** Driving support system information display area

When driving support system informa-

tion is displayed on the content display area, the system operating state will not be displayed in this area.

- E** RSA (Road Sign Assist) display area (if equipped) (→P.231)

### ■ Content display area (center)

- Driving support system information display (→P.102)
- Settings display (→P.103)
- Warning message display
- Blank (No items) (→P.103)

### ■ Content display area (left/right)

- Fuel Economy (→P.100)
- ECO Accelerator Guidance/“Eco Score” (→P.100)
- Driving time since starting/EV Driving Ratio (→P.102)
- Driving support system information display (→P.102)
- Navigation system-linked information display (→P.102) (if equipped)
- Audio system-linked display (→P.102)
- Drive information (→P.102)
- Energy monitor (→P.107)
- AWD operation status display (→P.103)
- Blank (No items) (→P.103)

### ■ Liquid crystal display

Small spots or light spots may appear on the display. This phenomenon is characteristic of liquid crystal displays, and there is no problem continuing to

use the display.

### ■ When changing driving mode

Background color of the multi-information display is changed following the selected driving mode. (→P.278)

#### WARNING

##### ■ Caution for use while driving

- When operating the multi-information display while driving, pay extra attention to the safety of the area around the vehicle.
- Do not look continuously at the multi-information display while driving as you may fail to see pedestrians, objects on the road, etc. ahead of the vehicle.



##### ■ The information display at low temperatures

→P.87

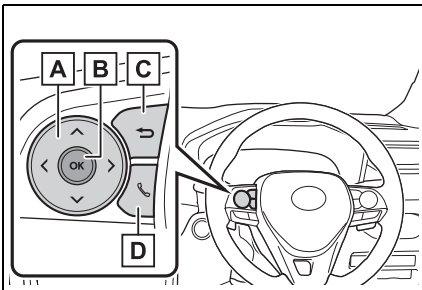
### Meter control switches



**A** : Change the screen, display the cursor and move the cursor up/down

 : Change displayed content and scroll up/down the screen

**B** Press: Enter/Set  
Press and hold: Reset/Display customizable items

**C** Return to the previous screen

**D** Call sending/receiving and history display

Linked with the hands-free system, sending or receiving call is displayed. For details regarding the hands-free system, refer to the "Multimedia Owner's Manual".

### Changing the display



The multi-information display is operated using the meter control switches.

#### ■ Changing the meter display type setting

The meter display type setting can be changed on . (→P.103)

#### ■ Changing the screen



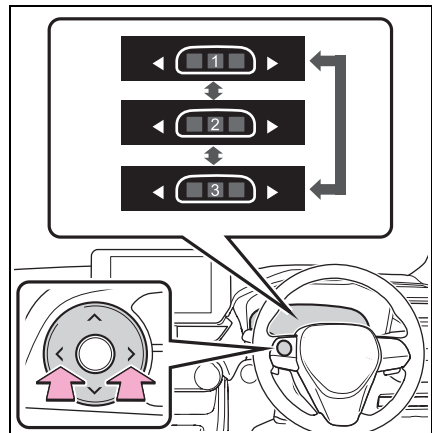

Select items from the combination of 3 screens to display on each 3 content display areas.

Press  or  of the meter control switches to scroll the screen.











### ■ Changing the display contents

Switches items displayed on each contents display area (left/center/right).

- 1 Press and hold  to display the cursor on the content display area (center).
- 2 Press  or  to move the cursor and select the content display area.
- 3 Press  or  to select the display items.

### ■ Items displayed in the content display area

Select items to enable/disable on the content display area (left/right).

- 1 Press and hold  to display the cursor on the content display area (center).
- 2 Press  or  to move the cursor and select the content display area.
- 3 Contents display area (left):  
Press  to display contents list.  
Contents display area (right):  
Press  to display contents list.
- 4 Press  or  to select the display items.
- 5 Press  to enable/disable items.

## Fuel Economy

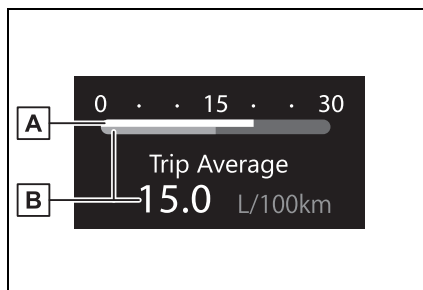

### A Current fuel economy

Displays the instantaneous current fuel Economy.

### B Average fuel economy

Displays the average fuel economy since the function was reset or the average fuel economy after starting.\*1, 2, 3

The average fuel economy selected by “Fuel Economy” on the  screen is displayed.

\*1: Use the displayed fuel consumption as a reference only.

\*2: Average fuel economy after starting is reset each time the hybrid system stops.

\*3: Average fuel economy since the function was reset can be reset by pressing and holding .

## ECO Accelerator Guidance/“Eco Score”

Displays a reference operation range for using the accelerator pedal according to driving conditions, and a score result that evaluates the current driving status.

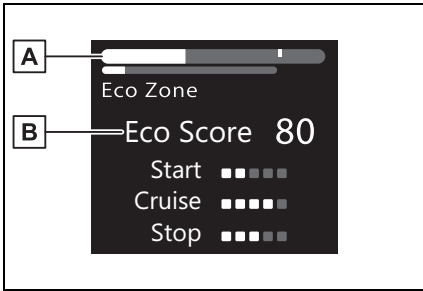

**A** ECO Accelerator Guidance

**B** “Eco Score”

■ **ECO Accelerator Guidance**

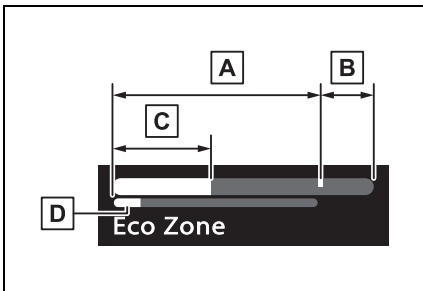

**A** ECO area

Shows that the vehicle is being driven in an Eco-friendly manner.

**B** Power area

Shows that an Eco-friendly driving range is being exceeded (during full power driving etc.).

**C** Current acceleration

**D** Reference operation range

A zone is displayed in blue under the Eco area which can be used as a reference operation range for using the accelerator pedal according to driving conditions such as starting off and cruising.

The ECO Accelerator Guidance display changes according to the driving status,

such as when starting off or cruising. It is easier to drive in an Eco-friendly manner by driving according to the display showing the accelerator pedal operations and staying within the reference operation range.

■ **“Eco Score”**

The driving status for the following 3 situations are evaluated in 5 levels: Smooth start-off acceleration (“Start”), driving without sudden acceleration (“Cruise”) and smooth stopping (“Stop”). Each time the vehicle is stopped, a score result is displayed out of a perfect score of 100 points.

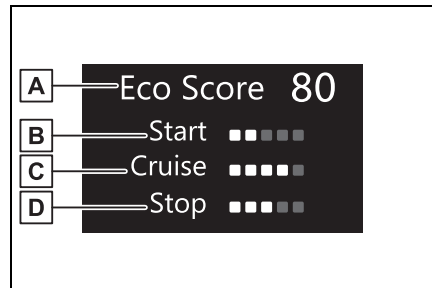

**A** Score result

**B** Eco start status



**C** Eco cruise status

**D** Eco stop status

3 situations are displayed with each icon while driving.

How to read the bar display:

Score	Bar display
Unrated	

Score	Bar display
Low	
High	

After starting off, “Eco Score” display does not start until the vehicle speed exceeds approximately 30km/h (19mph).

The “Eco Score” is reset each time the vehicle starts off to start a new evaluation.

**ECO Accelerator Guidance/“Eco Score” will not operate when**

The ECO Accelerator Guidance/“Eco Score” will not operate in the following situations:

- The Hybrid System Indicator is not operating.
- The vehicle is being driven using the dynamic radar cruise control with full-speed range.

**EV Ratio/EV Driving Ratio**

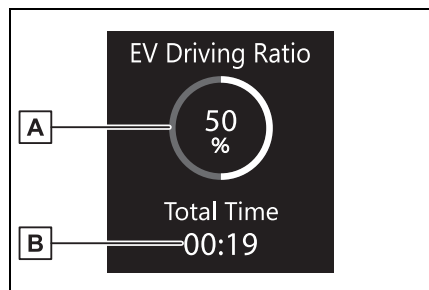

**A** EV driving ratio after starting

Displays the percentage of EV driving since the hybrid system was started.\*

**B** Elapsed time after starting

Displays the elapsed time since hybrid system was started.\*

\*: It is reset each time the hybrid system stops.

**Driving support system information display**

Select to display the operational status of the following systems:

- LTA (Lane Tracing Assist)\* (→P.220)
- Cruise control\* (→P.246)
- Dynamic radar cruise control with full-speed range\* (→P.234)

\*: If equipped

**Navigation system-linked display (if equipped)**

Select to display the following navigation system-linked information.

- Route guidance to destination
- Street name
- Compass

**Audio system-linked display**

The operating conditions of the audio system can be displayed on the multi-information display.

**Driving information display**

**Drive information**

2 items that are selected using the “Drive Info Items” setting (average speed and distance) can be displayed vertically.



Use the displayed information as a reference only.

- “Average Speed”: Displays the average vehicle speed since hybrid system start\*
- “Distance”: Displays the distance driven since hybrid system start\*
- “Total Time”: Displays elapsed time since hybrid system start\*

\*: These items are reset each time the hybrid system stops.

### ■ Trip information

2 items that are selected using the “TRIP A Items” or “TRIP B Items” setting (average speed and distance) can be displayed vertically.

Use the displayed information as a reference only.

- “Average Speed”: Displays the average vehicle speed since the display was reset\*
- “Distance”: Displays the distance driven since the display was reset\*
- “Total Time”: Displays elapsed time since the display was reset\*

\*: To reset, display the desired item and press and hold .

## Energy monitor

→P.107

## AWD system display (AWD models)

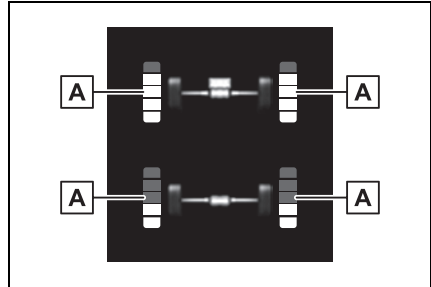

### A Torque distribution display

Displays the drive status of each wheel in 6 steps from 0 to 5.

The illustration used is intended as an example, and may differ from the image that is actually displayed on the multi-information display.



## Blank (No items)



Displays no drive information contents on the multi-information display.



## Settings display

Vehicle settings and the content displayed on the screen can be changed by using the meter control switches.



### ■ Setting procedure

- 1 Press and hold  to display the cursor on the content display area (center).
- 2 Press  or  with the cursor on the content display area

(center) to select  and then press .

- 3 Press  or  of the meter control switches and move the cursor to select the item for changing settings.

If the function is turned on and off or the volume, etc. is changed on the setting screen, the setting is changed each time  is pressed.

For functions that allow operation contents, display contents, etc., to be selected, the setting screen is displayed by pressing and holding . When the setting screen is displayed, select the setting or desired value (time, etc.) with .

- 4 After changing the settings, press  of the meter control switches.

### ■ Adjust Meter Brightness

Select to adjust the brightness of the instrument cluster lights.

### ■ LTA (Lane Tracing Assist) (if equipped) (→P.220)

Select to set up the following items.

- “Lane Centre”  
Select to enable/disable Lane the lane centering function.
- “Sensitivity”  
Select to set the lane departure alert sensitivity.
- “Sway Warning”  
Select to enable/disable the vehicle sway warning.
- “Sway Sensitivity”

Select to set the vehicle sway warning sensitivity.

### ■ BSM (Blind Spot Monitor) (if equipped) (→P.249)

Select to set up the following items.

- BSM (Blind Spot Monitor) on/off  
Select to enable/disable the BSM system.
- “Sensitivity”  
Select to change the alert timing for an approaching vehicle.
- “Brightness”  
Select to switch the brightness of the outside rear view mirror indicators. (→P.249)

### ■ PCS (Pre-Collision System) (if equipped)

Select to set up the following items.

- PCS on/off  
Select to enable/disable the pre-collision system.
- “Sensitivity”  
Select to change the pre-collision warning timing.

### ■ Toyota parking assist-sensor (→P.253)

Select to set up the following items.

- Toyota parking assist-sensor on/off  
Select to enable/disable the Toyota parking assist-sensor.
- “Volume”  
Select to set the volume of the buzzer which sounds when the Toyota parking assist-sensor is

operated.

### ■ **RCTA (Rear Cross Traffic Alert) (if equipped) (→P.263)**

Select to set up the following items.

- **RCTA (Rear Cross Traffic Alert) on/off**

Select to enable/disable the RCTA system.

- **“Volume”**

Select to set the volume of the buzzer which sounds when the RCTA is operated.

### ■ **PKSB (Parking Support Brake System) (if equipped) (→P.268)**

Select to enable/disable the Parking Support Brake function.

### ■ **RSA (Road Sign Assist) (if equipped) (→P.231)**

Select to set up the following items.

- **Road Sign Assist on/off**

Select to enable/disable the RSA (Road Sign Assist).

- **“Notification Method”**

Select to change each notification method used to notify the driver when the system recognizes excess speed and Do Not Enter sign.

- **“Notification Level”**

Select to change each notification level used to notify the driver when the system recognizes a speed limit sign.

### ■ **Vehicle Settings**

-  **PBD (Power Back Door) (if equipped)**

Select to set up the following items.

- **System settings**

Select to enable/disable the power back door system.

- **“Hands Free”\***

Select to enable/disable the Hands Free Power Back Door.

- **“Opening Adjustment”**

Select the open position when power back door is fully open.

- **“Volume”**

Select to set the volume of the buzzer which sounds when the power back door system operates.

\*: Vehicles with Hands Free Power Back Door

- **Rear Seat Reminder (→P.117)**

Select to enable/disable the rear seat reminder function.

### ■ **Settings**

- **“Language”**

Select to change the language on the multi-information display.

- **“Units”**

Select to change the unit of measure for fuel consumption.

- **Meter Type**

Select to change the meter type setting.

- **Meter Style**

Select to change the meter style.

- **Dial Type**

Select to change dial type. (→P.83)

-  **EV indicator**

Select to enable/disable the EV

indicator.

- **Fuel Economy**  
Select to change the display on Fuel Economy. (→P.100)
- **“Hybrid System”**  
Select to enable/disable the ECO Accelerator Guidance (→P.100)
- **Drive Info**  
Select to change displayed items on drive information display. (→P.102)
- **Pop-Up Display**  
Select to enable/disable the pop-up displays, which may appear in some situations.
- **Default Settings**  
Select to reset the meter display settings.

#### ■ **Brightness of the meter lights (day mode and night mode)**

The brightness of the meter lights can be adjusted individually.

In the following situations, the meters changes between day mode and night mode.

- **Day mode:** When the tail lights are off or when the tail lights are on but the surrounding area is bright
- **Night mode:** When the tail lights are on and the surrounding area is dark

#### ■ **Suspension of the settings display**

- Some settings cannot be changed while driving. When changing settings, park the vehicle in a safe place.
- If a warning message is displayed, operation of the settings display will be suspended.

### **WARNING**

#### ■ **Cautions during setting up the display**

As the hybrid system needs to be operating during setting up the display, ensure that the vehicle is parked in a place with adequate ventilation. In a closed area such as a garage, exhaust gases including harmful carbon monoxide (CO) may collect and enter the vehicle. This may lead to death or a serious health hazard.

### **NOTICE**

#### ■ **During setting up the display**

To prevent 12-volt battery discharge, ensure that the hybrid system is operating while setting up the display features.

### **Warning message display**

Select to display warning messages and measures to be taken if a malfunction is detected.

(→P.392)

### **Convenience Services (Suggestion function)**

Displays suggestions to the driver in the following situations. To select a response to a displayed suggestion, use the meter control switches.

#### ■ **Suggestion to turn off the headlights**

If the headlights are left on for a certain amount of time after the power switch has been turned off, a suggestion message will be dis-

played.

When the headlight switch is in the AUTO position:

The message asking if you wish to turn the headlights off is displayed.

To turn the headlights off, select “Yes”.

If the driver’s door is opened after the power switch is turned off, this suggestion message will not be displayed.

### ■ Suggestion to close the power windows (linked to windshield wiper operation)

If the windshield wipers are operated with a power window open, a suggestion message will be displayed asking if you wish to close the power windows.

To close all of the power windows, select “Yes”.

### ■ Customization

Some functions can be customized. (→P.429)

## Energy monitor/consumption screen

You can view the status of your hybrid system and fuel consumption information on the multi-information display and Multimedia Display.

## System components

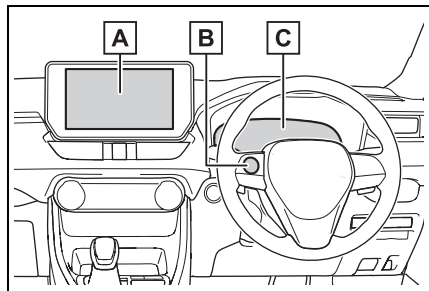

- A** Multimedia Display
- B** Meter control switches
- C** Multi-information display

## Energy monitor

The energy monitor can be used to check the vehicle drive status, hybrid system operation status and energy regeneration status.

### ■ Display procedure

- ▶ Multi-information display

Use the meter control switches, display the energy monitor on the multi-information display.

For detail regarding the multi-information display, refer to P.93, 103

► Multimedia Display

Press  on the main menu, then press “Energy flow” on the sub menu.

For detail regarding the Multimedia Display, refer to “Multimedia Owner’s Manual”.

■ Reading the display

The arrows will appear in accordance with the energy flow. When there is no energy flow, arrows will not be displayed.

The color of the arrows will change as follows

Blue: When the hybrid battery (traction battery) is regenerated or charged.

Orange: When the hybrid battery (traction battery) is in use.

Red: When the gasoline engine is in use.

► Multi-information display (vehicles with 7-inch display)

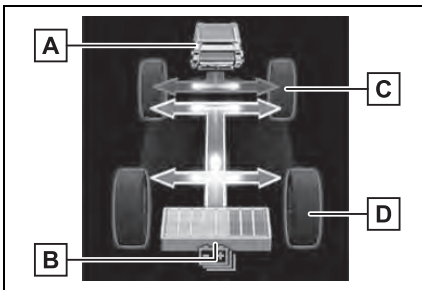

The image shows all the arrows as an example. The actual display will vary depending on conditions.

- A** Gasoline engine
- B** Hybrid battery (traction battery)
- C** Front tires

**D** Rear tires\*

\*: For FF vehicles, the arrows to **D** are not displayed.

► Multi-information display (vehicles with 12.3-inch display)

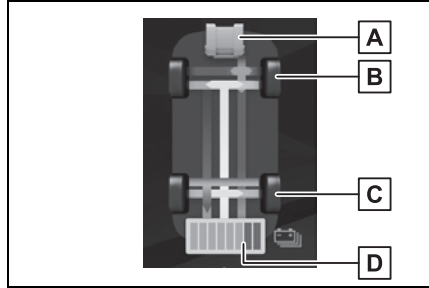

The image shows all the arrows as an example. The actual display will vary depending on conditions.

- A** Gasoline engine
- B** Front tires
- C** Rear tires\*
- D** Hybrid battery (traction battery)

\*: For FF vehicles, the arrows to **C** are not displayed.

► Multimedia Display

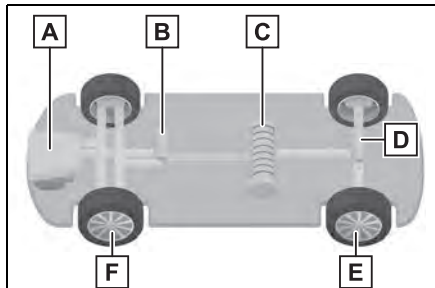

The image shows all the arrows as an example. The actual display will vary depending on conditions.

- A** Gasoline engine
- B** Front electric motor (traction motor)
- C** Hybrid battery (traction battery)
- D** Rear electric motor (traction motor) (AWD vehicles only)
- E** Rear tires\*
- F** Front tires

\*: For FF vehicles, the arrows to **E** are not displayed.

### ■ Hybrid battery (traction battery) status

The display changes in 8 levels according to the remaining charge amount of the hybrid battery (traction battery).

- The figure shows the multi-information display as an example for explanation.
- These images are examples only, and may vary slightly from actual conditions.

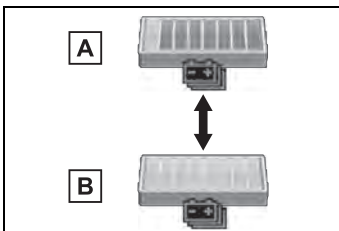

- A** Low
- B** High

### ■ Remaining charge amount warning of hybrid battery (traction battery)

- The buzzer sounds intermittently when the hybrid battery (traction battery) remains without charging while the shift lever is in N, or the remaining charge amount drops below a certain level. If the remaining charge amount

drops further, the buzzer sounds continuously.

- When a warning message is shown on the multi-information display and the buzzer sounds, follow the instructions displayed on the screen to perform troubleshooting.

## Consumption screen

### ■ Display procedure

Press on the main menu, then press “Trip information” on the sub menu.

For detail regarding the Multimedia Display, refer to “Multimedia Owner’s Manual”.

### ■ Current fuel consumption screen

If a screen other than current fuel consumption screen is displayed, press “Current”.

Use the displayed average fuel consumption as a reference.

Some screens may vary depending on the type of multi-media display.

The image is an example only, and may vary slightly from actual conditions.

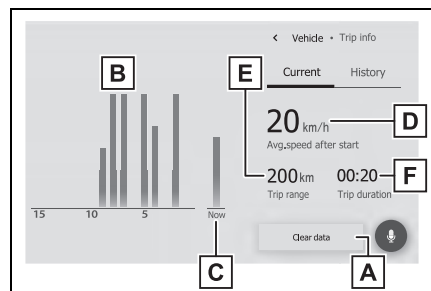

- A** Resetting the consumption data
- B** Fuel consumption in the past 15

minutes

- C** Current fuel consumption
- D** Average vehicle speed since the hybrid system was started.
- E** Trip range
- F** Elapsed time since the hybrid system was started.

### ■ History screen

If a screen other than history screen is displayed, press “History”.

Use the displayed average fuel consumption as a reference.

Some screens may vary depending on the type of multi-media display.

The image is an example only, and may vary slightly from actual conditions.

pressing “Update” to measure the current fuel consumption again.

### ■ Resetting the data

The fuel consumption data can be deleted by pressing “Clear data”.

### ■ Trip range

Displays the estimated maximum distance that can be driven with the quantity of fuel remaining.

This distance is computed based on your average fuel consumption. As a result, the actual distance that can be driven may differ from that displayed.

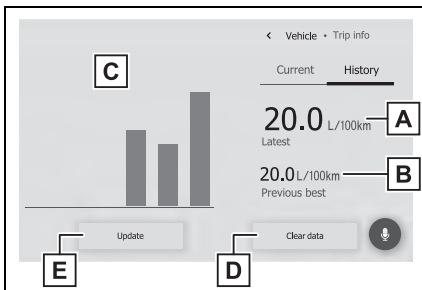

- A** Latest fuel consumption
- B** Best recorded fuel consumption
- C** Previous fuel consumption record
- D** Resetting the history data
- E** Updating the latest fuel consumption data

### ■ Updating the history data

Update the latest fuel consumption by



**3-1. Key information**

Keys..... **112**

**3-2. Opening, closing and locking the doors**

Side doors ..... **115**

Back door ..... **120**

Smart entry & start system  
..... **129**

**3-3. Adjusting the seats**

Front seats..... **134**

Rear seats ..... **135**

Driving position memory ... **137**

Head restraints ..... **140**

**3-4. Adjusting the steering wheel and mirrors**

Steering wheel..... **142**

Inside rear view mirror ..... **143**

Digital Rear-view Mirror .... **144**

Outside rear view mirrors . **153**

**3-5. Opening, closing the windows and moon roof**

Power windows..... **155**

Moon roof ..... **158**

## Keys

### Key types

The following keys are provided with the vehicle.

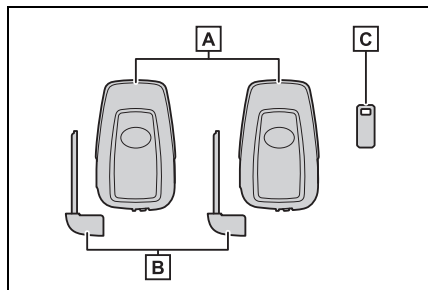

#### A Electronic keys

- Operating the smart entry & start system (→P.129)
- Operating the wireless remote control function (→P.113)

#### B Mechanical keys

#### C Key number plate

### ■ When riding in an aircraft

When bringing an electronic key onto an aircraft, make sure you do not press any buttons on the electronic key while inside the aircraft cabin. If you are carrying an electronic key in your bag etc., ensure that the buttons are not likely to be pressed accidentally. Pressing a button may cause the electronic key to emit radio waves that could interfere with the operation of the aircraft.

### ■ Electronic key battery depletion

- The standard battery life is 1 to 2 years.
- If the battery becomes low, an alarm will sound in the cabin and a message will be displayed on the multi-information display when the hybrid system stops.

- To reduce key battery depletion when the electronic key is to not be used for long periods of time, set the electronic key to the battery-saving mode. (→P.131)

- As the electronic key always receives radio waves, the battery will become depleted even if the electronic key is not used. The following symptoms indicate that the electronic key battery may be depleted. Replace the battery when necessary.

- The smart entry & start system or the wireless remote control does not operate.
- The detection area becomes smaller.
- The LED indicator on the key surface does not turn on.

You can replace the battery by yourself (→P.363). However, as there is a danger that the electronic key may be damaged, it is recommended that replacement is carried out by your Toyota dealer.

- To avoid serious deterioration, do not leave the electronic key within 1 m (3 ft.) of the following electrical appliances that produce a magnetic field:
  - TVs
  - Personal computers
  - Cellular phones, cordless phones and battery chargers
  - Table lamps
  - Induction cookers

### ■ If a message regarding the state of the electronic key or power switch mode, etc. is shown

To prevent trapping the electronic key inside the vehicle, leaving the vehicle carrying the electronic key on your person without turning the power switch to OFF or other passengers from unintentionally taking the key out of the vehicle, etc., a message that prompts the user to confirm the state of the electronic key or power switch mode may be shown on the multi-information display. In those cases, follow the instructions on the display immediately.

■ **If “Key Battery Low Replace Key Battery” is displayed on the multi-information display**

The electronic key has a low battery. Replace the electronic key battery. (→P.363)

■ **Replacing the battery**

→P.363

■ **Confirmation of the registered key number**

The number of keys already registered to the vehicle can be confirmed. Ask your Toyota dealer for details.

■ **If “A New Key has been Registered Contact Your Dealer for Details” is displayed on the multi-information display**

This message will be displayed each time the driver's door is opened when the doors are unlocked from the outside for approximately 10 days after a new electronic key has been registered. If this message is displayed but you have not had a new electronic key registered, ask your Toyota dealer to check if an unknown electronic key (other than those in your possession) has been registered.



**NOTICE**

■ **To prevent key damage**

- Do not drop the keys, subject them to strong shocks or bend them.
- Do not expose the keys to high temperatures for long periods of time.
- Do not get the keys wet or wash them in an ultrasonic washer, etc.
- Do not attach metallic or magnetic materials to the keys or place the keys close to such materials.
- Do not disassemble the keys.

● Do not attach a sticker or anything else to the surface of the electronic keys.

● Do not place the keys near objects that produce magnetic fields, such as TVs, audio systems and induction cookers.

● Do not place the keys near medical electrical equipment such as low-frequency therapy equipment or microwave therapy equipment, and do not receive medical attention with the keys on your person.

■ **Carrying the electronic key on your person**

Carry the electronic key 10 cm (3.9 in.) or more away from electric appliances that are turned on. Radio waves emitted from electric appliances within 10 cm (3.9 in.) of the electronic key may interfere with the key, causing the key to not function properly.

■ **In case of a smart entry & start system malfunction or other key-related problems**

→P.406

■ **When an electronic key is lost**

→P.405

## Wireless remote control

The electronic keys are equipped with the following wireless remote control:

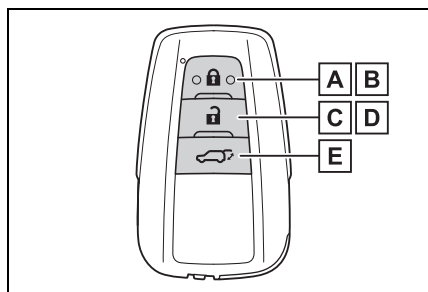

- A** Locks all the doors (→P.115)
- B** Closes the side windows\*<sup>1</sup> and the moon roof\*<sup>1, 2</sup> (→P.115)
- C** Unlocks all the doors (→P.115)
- D** Opens the side windows\*<sup>1</sup> and the moon roof\*<sup>1, 2</sup> (→P.115)
- E** Opens and closes the power back door\*<sup>2</sup> (→P.123)

\*<sup>1</sup>: These settings must be customized at your Toyota dealer.

\*<sup>2</sup>: If equipped

### Using the mechanical key

To take out the mechanical key, slide the release lever **A** and take the key out.

The mechanical key can only be inserted in one direction, as the key only has grooves on one side. If the key cannot be inserted in a lock cylinder, turn it over and re-attempt to insert it.

After using the mechanical key, store it in the electronic key. Carry the mechanical key together with the electronic key. If the electronic key battery is depleted or the entry function does not operate properly, you will need the

mechanical key. (→P.406)

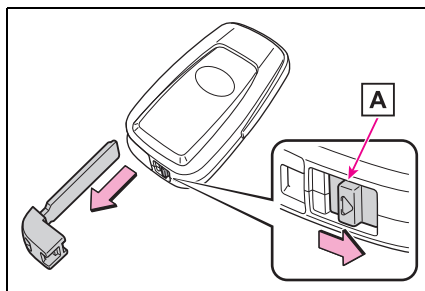

#### ■ If you lose your keys

→P.405

#### ■ If a wrong key is used

The key cylinder rotates freely to isolate inside mechanism.

## Side doors

The vehicle can be locked and unlocked using the entry function, wireless remote control, door lock switches or inside lock buttons.

### Unlocking and locking the doors from the outside

#### ■ Using the entry function (vehicles with smart entry & start system equipped with entry function)

Carry the electronic key to enable this function.

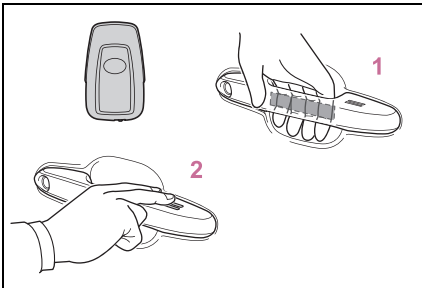

- 1 Grip the front door handle to unlock the doors.

Make sure to touch the sensor on the back of the handle.

The doors cannot be unlocked for 3 seconds after the doors are locked.

- 2 Touch the lock sensor (the indentation on the upper part of the door handle) to lock the doors.

Check that the door is securely locked.

#### ■ Using the wireless remote control

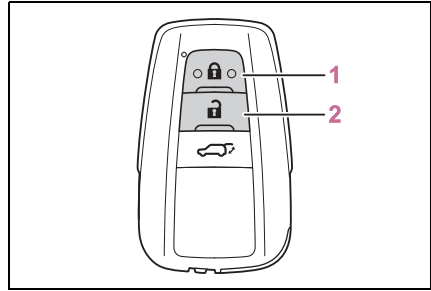

- 1 Locks all the doors

Check that the door is securely locked. Press and hold to close the side windows and moon roof (if equipped).\*

- 2 Unlocks all the doors



Press and hold to open the side windows and moon roof (if equipped).\*

\*: These settings must be customized at your Toyota dealer.





#### ■ Switching the door unlock function (vehicles with smart entry & start system equipped with entry function)

It is possible to set which doors the entry function unlocks using the wireless remote control. Operate the switching operation in the vehicle or within approximately 1 m (3.2 ft.) of the vehicle.

- 1 Turn the power switch to OFF.
- 2 When the indicator light on the key surface is not on, press and hold

 or  for approximately 5 seconds while pressing and holding  .

The setting changes each time an operation is performed, as shown below. (When changing the setting continuously, release the buttons, wait for at least 5 seconds, and repeat step 2.)

Multi-information display/Beep	Unlocking function
  Exterior: Beeps 3 times Interior: Pings once	Holding the driver's door handle unlocks only the driver's door. Holding the front passenger's door handle or pressing the back door opener switch unlocks all the doors.
  Exterior: Beeps twice Interior: Pings once	Holding either front door handle or pressing the back door opener switch unlocks all the doors.

\*1: Vehicles with 7-inch multi-information display

\*2: Vehicles with 12.3-inch multi-information display

### ■ Impact detection door lock release system

In the event that the vehicle is subject to a strong impact, all the doors are unlocked. Depending on the force of the impact or the type of accident, however, the system may not operate.

### ■ Operation signals

Doors: A buzzer sounds and the emergency flashers flash to indicate that the doors have been locked/unlocked using the entry function (if equipped) or wireless remote control. (Locked: Once; Unlocked: Twice)

Side windows and moon roof (if

equipped): A buzzer sounds to indicate that the side windows and moon roof are operating using the wireless remote control.

### ■ Security feature

If a door is not opened within approximately 30 seconds after the vehicle is unlocked using the entry function (if equipped) or wireless remote control, the security feature automatically locks the vehicle again. (However, depending on the location of the electronic key, the key may be detected as being in the vehicle. In this case, vehicle may be unlocked.)

### ■ When the door cannot be locked by the lock sensor on the upper part of the door handle (vehicles with smart entry & start system equipped with entry function)

If the door will not lock even when the topside sensor area is touched, try touching both the topside and underside sensor areas at the same time.

When gloves are being worn, remove the gloves.

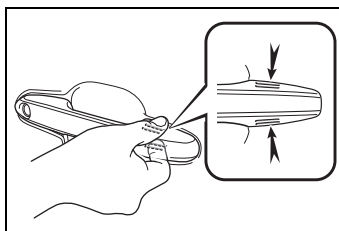

### ■ Door lock buzzer

A buzzer sounds continuously for 5 seconds in the following situations. Fully close all the doors and lock the vehicle once more.

- If an attempt to lock the doors using the smart entry & start system is made when a door other than the door you are locking is open.
- If an attempt to lock the doors using the wireless remote control is made when a door is open.

### ■ Conditions affecting the operation of the smart entry & start system or wireless remote control

→P.131

### ■ If the smart entry & start system or the wireless remote control does not operate properly

- Use the mechanical key to lock and unlock the doors. (→P.406)
- Replace the key battery with a new one if it is depleted. (→P.363)

### ■ If the 12-volt battery is discharged

The doors cannot be locked and unlocked using the smart entry & start system or wireless remote control. Lock or unlock the doors using the mechanical key. (→P.406)

### ■ Rear seat reminder function

- In order to remind you not to forget luggage, etc. in the rear seat, when the power switch is turned to OFF after any of the following conditions are met, a buzzer will sound and a message will be displayed on the multi-information display for approximately 6 seconds.
  - The hybrid system is started within 10 minutes after opening and closing a rear door.
  - A rear door has been opened and closed after the hybrid system was started.

However, if a rear door is opened and then closed within approximately 2 seconds, the rear seat reminder function may not operate.

- The rear seat reminder function determines that luggage, etc. has been placed in a rear seat based on opening and closing of a rear door. Therefore, depending on the situation, the rear seat reminder function may not operate and you may still forget luggage, etc. in the rear seat, or it may operate unnecessarily.
- The rear seat reminder function can be enabled/disabled. (→P.430)

### ■ Customization

Settings (e.g. unlocking function using a key) can be changed.  
(Customizable features: →P.433)



### WARNING

#### ■ To prevent an accident

Observe the following precautions while driving the vehicle. Failure to do so may result in a door opening and an occupant could be thrown out of the vehicle, resulting in death or serious injury.

- Ensure that all doors are properly closed and locked.
- Do not pull the inside handle of the doors while driving. Be especially careful for the driver's door, as the door may be opened even if the inside lock button is in locked position.
- Set the rear door child-protector locks when children are seated in the rear seats.

#### ■ When opening or closing a door

Check the surroundings of the vehicle such as whether the vehicle is on an incline, whether there is enough space for a door to open and whether a strong wind is blowing. When opening or closing the door, hold the door handle tightly to prepare for any unpredictable movement.

**WARNING**

■ **When using the wireless remote control or mechanical key and operating the power windows or moon roof (if equipped)**

Operate the power window or moon roof after checking to make sure that there is no possibility of any passenger having any of their body parts caught in the side window or moon roof. Also, do not allow children to operate the wireless remote control or mechanical key. It is possible for children and other passengers to get caught in the side window or moon roof.

## Unlocking and locking the doors from the inside

### ■ Using the door lock switch

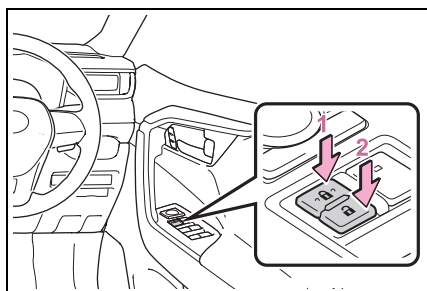

- 1 Locks all the doors
- 2 Unlocks all the doors

### ■ Using the inside lock buttons

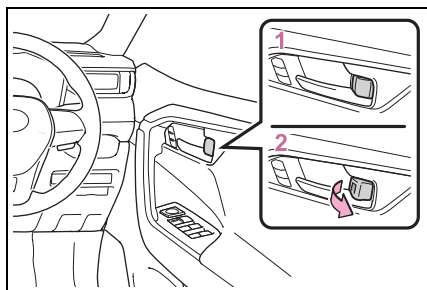

- 1 Locks the door
- 2 Unlocks the door

The driver's door can be opened by pulling the inside handle even if the lock button is in the lock position.

### ■ Locking the front doors from the outside without a key

- 1 Move the inside lock button to the lock position.
- 2 Close the door while pulling the door handle.

The door cannot be locked if the power switch is in ACC or ON, or the electronic key is left inside the vehicle.

Depending on the position of the electronic key, the key may not be detected correctly and the door may be locked.

### ■ Open door warning buzzer

If the vehicle speed reaches 5 km/h (3 mph), a buzzer sounds to indicate that the door(s) or the hood is not fully closed.

The open door(s) or hood is displayed on the multi-information display.

### ■ When all the doors are locked with the entry function (if equipped) or wireless remote control

- The doors cannot be unlocked with the door lock switch.
- The door lock switch can be reset by unlocking all the doors with the entry function or wireless remote control.

## Rear door child-protector lock

The door cannot be opened from inside the vehicle when the lock is set.



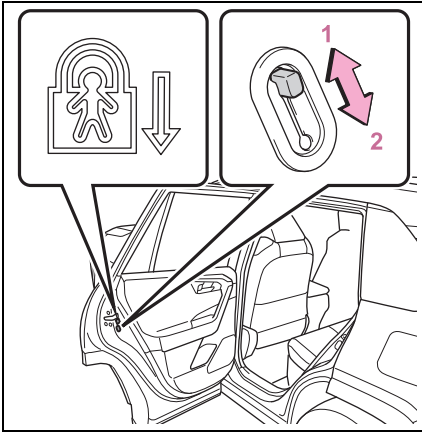

**1** Unlock

**2** Lock

These locks can be set to prevent children from opening the rear doors. Push down on each rear door switch to lock both rear doors.

### Automatic door locking and unlocking systems

The following functions can be set or canceled:

For instructions on customizing, refer to P.429.

Function	Operation
Shift position linked door unlocking function	All doors are automatically unlocked when shifting the shift lever to P.
Driver's door linked door unlocking function	All doors are automatically unlocked when driver's door is opened within approximately 45 seconds after turning the power switch to OFF.

Function	Operation
Speed linked door locking function	All doors are automatically locked when vehicle speed is approximately 20 km/h (12mph) or higher.
Shift position linked door locking function	All doors are automatically locked when shifting the shift lever to position other than P.

## Back door

**The back door can be locked/unlocked and opened/closed by the following procedures.**



### WARNING

Observe the following precautions. Failure to do so may result in death or serious injury.

#### ■ Before driving

- Make sure that the back door is fully closed.  
If the back door is not fully closed, it may open unexpectedly while driving and hit near-by objects or luggage in the luggage compartment may be thrown out, causing an accident.
- Do not allow children to play in the luggage compartment.  
If a child is accidentally locked in the luggage compartment, they could get heat exhaustion or other injuries.
- Do not allow a child to open or close the back door.  
Doing so may cause the back door to operate unexpectedly, or cause the child's hands, head, or neck to be caught by the closing back door.

#### ■ Important points while driving

- Keep the back door closed while driving.  
If the back door is left open, it may hit near-by objects or luggage in the luggage compartment may be thrown out, causing an accident.
- Never let anyone sit in the luggage compartment.  
In the event of sudden braking, sudden swerving or a collision, they are susceptible to death or serious injury.

#### ■ Back door handles

Do not hang any object to the back door handles.

If any object is hung, the back door may suddenly shut, causing parts of the body to be caught, resulting in death or serious injury.

#### ■ Operating the back door

Observe the following precautions. Failure to do so may cause parts of the body to be caught, resulting in death or serious injury.

- Remove any heavy loads, such as snow and ice, from the back door before opening it. Failure to do so may cause the back door to suddenly shut again after it is opened.
- When opening or closing the back door, thoroughly check to make sure the surrounding area is safe.
- If anyone is in the vicinity, make sure they are safe and let them know that the back door is about to open or close.
- Use caution when opening or closing the back door in windy weather as it may move abruptly in strong wind.
- Vehicles without power back door:  
The back door may suddenly shut if it is not opened fully. It is more difficult to open or close the back door on an incline than on a level surface, so beware of the back door unexpectedly opening or closing by itself. Make sure that the back door is fully open and secure before using the luggage compartment.

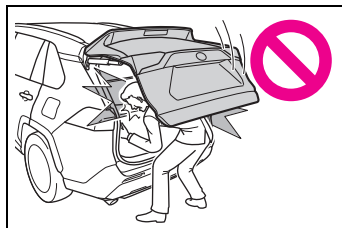

### WARNING

- Vehicles with power back door: The back door may suddenly shut if it is not opened fully, while on a steep incline. Make sure that the back door is secured before using the luggage compartment.
- When closing the back door, take extra care to prevent your fingers, etc. from being caught.

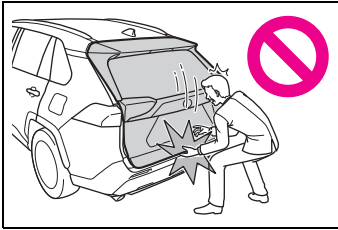

- Vehicles without power back door: When closing the back door, make sure to press it lightly on its outer surface. If the back door handle is used to fully close the back door, it may result in hands or arms being caught.
- Do not pull on the back door damper stay (vehicles without power back door) (→P.123) or back door spindle (vehicles with power back door) (→P.128) to close the back door, and do not hang on the back door damper stay (vehicles without power back door) or back door spindle (vehicles with power back door). Doing so may cause hands to be caught or the back door damper stay (vehicles without power back door) or back door spindle (vehicles with power back door) to break, causing an accident.

- Vehicles without power back door: If a bicycle carrier or similar heavy object is attached to the back door, it may suddenly shut again after being opened, causing someone's hands, head or neck to be caught and injured. When installing an accessory part to the back door, using a genuine Toyota part is recommended.

### Unlocking and locking the back door from the outside

- Using the entry function (vehicles with smart entry & start system equipped with entry function)

Carry the electronic key to enable this function.

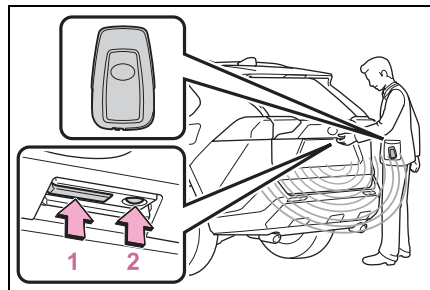

- 1 Unlocks all the doors

The doors cannot be unlocked for 3 seconds after the doors are locked.

- 2 Locks all the doors

Check that the door is securely locked.

- Using the wireless remote control

→P.115

- Operation signals

A buzzer sounds and the emergency flashers flash to indicate that the doors

have been locked/unlocked using the entry function (if equipped) or wireless remote control. (Locked: once; Unlocked: twice)

### ■ Security feature

If a door is not opened within approximately 30 seconds after the vehicle is unlocked using the entry function (if equipped) or wireless remote control, the security feature automatically locks the vehicle again. (However, depending on the location of the electronic key, the key may be detected as being in the vehicle. In this case, vehicle may be unlocked.)

## Unlocking and locking the back door from the inside

### ■ Using the door lock switch

→P.118

## Opening/closing the back door (vehicles without power back door)

### ■ Open

Raise the back door while pressing up the back door opener switch.

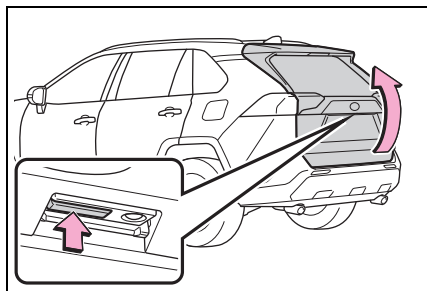

### ■ Close

Lower the back door using the back door handle **A**, and make sure to push the back door down from the

outside to close it.

Be careful not to pull the back door sideways when closing the back door with the handle.

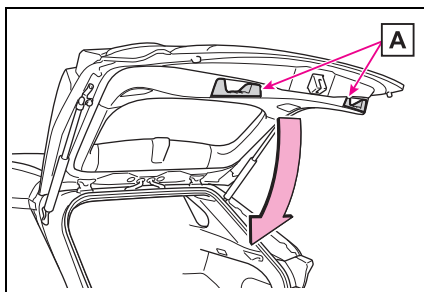

### ■ Luggage compartment light

- The luggage compartment light turns on when the back door is opened.
- When the power switch is turned to OFF, the light will go off automatically after 20 minutes.

### ■ If the back door opener is inoperative

The back door can be unlocked from the inside.

- 1 Remove the cover.

To prevent damage, cover the tip of the screwdriver with a rag.

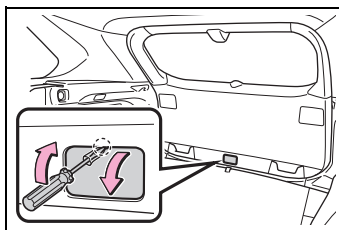

- 2 Loosen the screw.

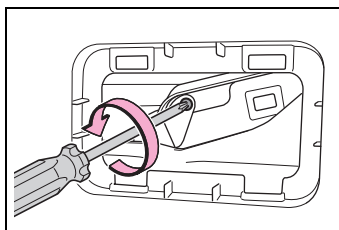

## 3 Turn the cover.

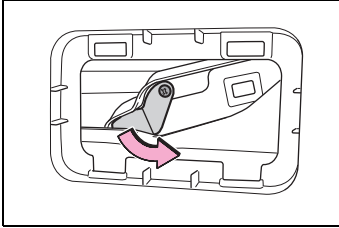

## 4 Move the lever.

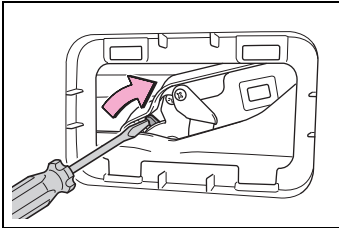

## 5 When installing, reverse the steps listed.

## ■ Open door warning buzzer

→P.118



## NOTICE

## ■ Back door damper stays

The back door is equipped with damper stays that hold the back door in place.

Observe the following precautions.

Failure to do so may cause damage to the back door damper stay, resulting in malfunction.

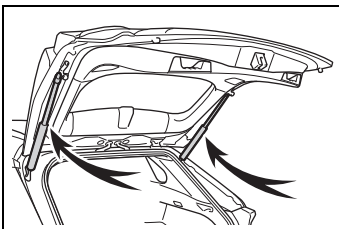

- Do not attach any foreign objects, such as stickers, plastic sheets, or adhesives to the damper stay rod.

- Do not touch the damper stay rod with gloves or other fabric items.
- Do not attach any accessories other than genuine Toyota parts to the back door.
- Do not place your hand on the damper stay or apply lateral forces to it.

### Opening/closing the back door (vehicles with power back door)

#### ■ Using the wireless remote control

Press and hold the switch.

The power back door automatically opens/closes.

Unlock the back door before operating.

Pressing the switch while the power back door is opening/closing stops the operation. When the switch is pressed and held again during the halted operation, the back door will perform the reverse operation.

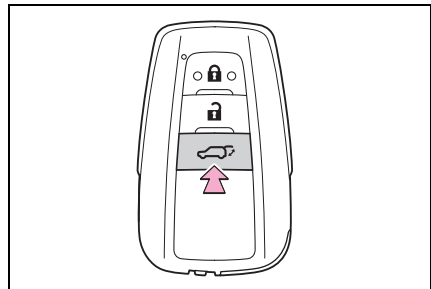

#### ■ Using the power back door switch on the instrument panel

Press and hold the switch.

The power back door automatically

opens/closes.

Unlock the back door before operating.

Pressing the switch while the power back door is opening/closing stops the operation. When the switch is pressed and held again during the halted operation, the back door will perform the reverse operation.

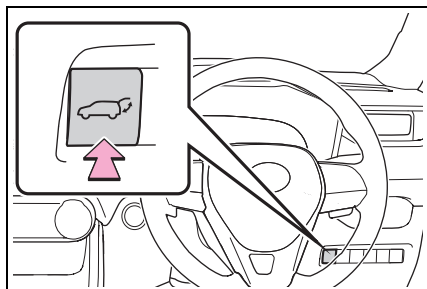

### ■ Using the back door opener switch

When the back door is unlocked:  
Press the back door opener switch.

When the back door is locked:  
While carrying the electronic key on your person, press and hold the back door opener switch.

The power back door automatically opens.

Pressing the switch while the power back door is opening/closing stops the operation.

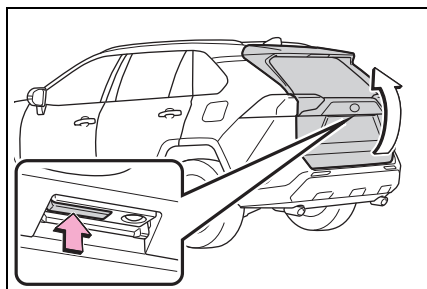

### ■ Using the power back door switch on the back door

Press the switch.

The power back door automatically closes.

Pressing the switch while the power back door is operating will stop the operation. When the switch is pressed again during the halted operation, the back door will perform the reverse operation.

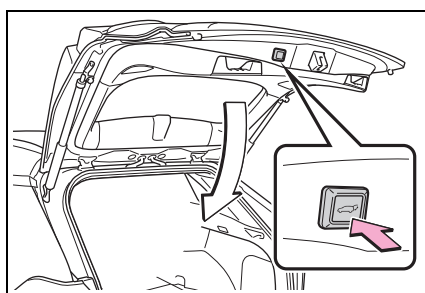

### ■ Using the back door handles

Lower the back door using the back door handle **A**.

The back door closing assist (→P.125) will be activated, and the power back door will fully close automatically.

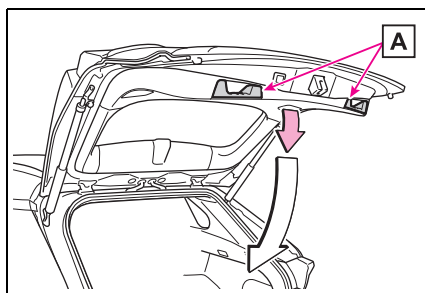

### ■ Luggage compartment light

- The luggage compartment light turns on when the back door is opened.
- When the power switch is turned to

OFF, the light will go off automatically after 20 minutes.

### ■ Back door closer

In the event that the back door is left slightly open, the back door closer will automatically close it to the fully closed position.

Whatever the state of the power switch, the back door closer operates.

### ■ Power back door operating conditions

The power back door can automatically open and close under the following conditions:

- When the power back door system is enabled. (→P.94)

- When the back door is unlocked.

However, if the back door opener switch is pressed and held while carrying the electronic key on your person, the power back door will be operated even if the back door is locked. (→P.124)

- When the power switch is in ON, in addition to the above for the opening operations, the back door operates for any of the following conditions:

- Parking brake is engaged
- The brake pedal is depressed
- The shift lever is in P.

### ■ Operation of the power back door

- A buzzer sounds and the emergency flashers flash twice to indicate that the back door is opening/closing.

- When the power back door system is disabled, the power back door does not operate but it can be opened and closed by hand.

- When the power back door automatically opens, if an abnormality due to people or objects is detected, operation will stop.

### ■ Jam protection function

Sensors are equipped on both sides of the power back door. If anything obstructs the power back door while it is closing, the back door will automatically

operate in the opposite direction or stop.

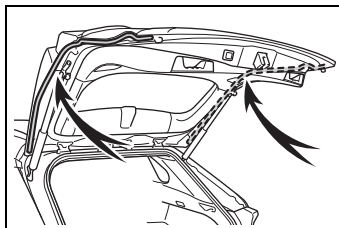

### ■ Fall-down protection function

While the power back door is opening automatically, applying excessive force to it will stop the opening operation to prevent the power back door from suddenly shutting.

### ■ Back door closing assist

If the back door is lowered manually when the back door is stopped at an open position, the back door will fully close automatically.

### ■ Back door reserve lock function (if equipped)

This function is a function which reserves locking of all doors, beforehand, when the power back door is open.

When the following procedure is performed, all the doors except the power back door are locked and then power back door will also be locked at the same time it is closed.

- 1 Close all doors, except the back door.
- 2 During the power back door closing operation, lock the doors using the smart entry & start system from the front doors (→P.115) or the wireless remote control. (→P.115)

A buzzer sounds and the emergency flashers flash to indicate that all the doors have been closed and locked.

- If the electronic key is placed inside the vehicle after starting a close operation via the door reserve lock function, the electronic key may become locked inside the vehicle.

- If the power back door does not fully

close due to the operation of the jam protection function, etc., while the back door is automatically closing after a door reserve lock operation is performed, the door reserve lock function is canceled and all the doors will unlock.

- Before leaving the vehicle, make sure that all the doors are closed and locked.

### ■ When reconnecting the 12-volt battery

To enable the power back door to operate properly, close the back door manually.

### ■ If the back door opener is inoperative

The back door can be unlocked from the inside.

- 1 Remove the cover.

To prevent damage, cover the tip of the screwdriver with a rag.

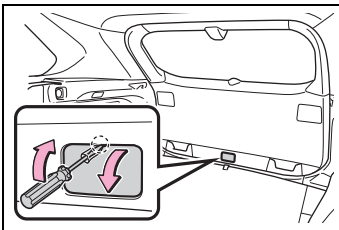

- 2 Loosen the screw.

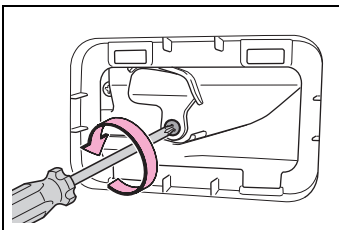

- 3 Turn the cover.

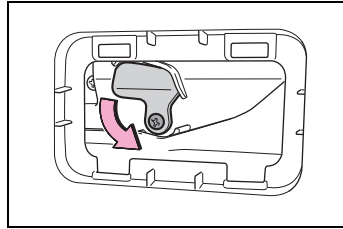

- 4 Move the lever.

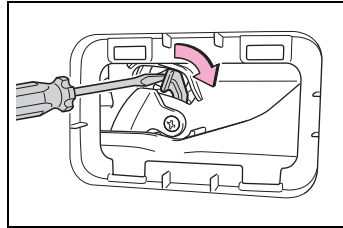

- 5 When installing, reverse the steps listed.

### ■ Customization

Settings (e.g. power back door opening angle) can be changed. (Customizable features: →P.435)

## ⚠ WARNING

### ■ Back door closer

- In the event that the back door is left slightly open, the back door closer will automatically close it to the fully closed position. It takes several seconds before the back door closer begins to operate. Be careful not to catch fingers or anything else in the back door, as this may cause bone fractures or other serious injuries.

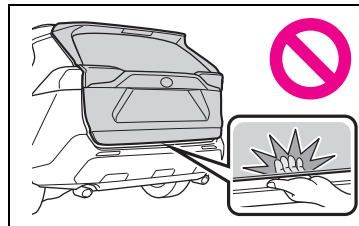



**WARNING**

- Use caution when using the back door closer as it still operates when the power back door system is canceled.

**■ Power back door**

Observe the following precautions when operating the power back door. Failure to do so may cause death or serious injury.

- Check the safety of the surrounding area to make sure there are no obstacles or anything that could cause any of your belongings to get caught.
- If anyone is in the vicinity, make sure they are safe and let them know that the back door is about to open or close.
- If the power back door system is turned off while the back door is operating automatically, the automatic operation is stopped. The back door then has to be operated manually. Take extra care when on an incline, as the back door may open or close unexpectedly.
- If the operating conditions of the power back door are no longer met, a buzzer may sound and the back door may stop opening or closing. The back door then has to be operated manually. Take extra care when on an incline, as the back door may open or close abruptly.
- On an incline, the back door may suddenly shut after it opens. Make sure the back door is fully open and secure.

- In the following situations, the power back door may detect an abnormality and automatic operation may be stopped. In this case, the back door has to be operated manually. Take extra care when on an incline, as the back door may open or close abruptly.

- When the back door contacts an obstacle
- When the 12-volt battery voltage suddenly drops, such as when the power switch is turned to ON or the hybrid system is started during automatic operation

- If a bicycle carrier or similar heavy object is attached to the back door, it may suddenly shut again after being opened, causing someone's hands, head or neck to be caught and injured. When installing an accessory part to the back door, using a genuine Toyota part is recommended.

**■ Jam protection function**

Observe the following precautions. Failure to do so may cause death or serious injury.

- Never use any part of your body to intentionally activate the jam protection function.
- The jam protection function may not work if something gets caught just before the back door fully closes. Be careful not to catch fingers or anything else.
- The jam protection function may not work depending on the shape of the object that is caught. Be careful not to catch fingers or anything else.



## NOTICE

### ■ Back door spindles

The back door is equipped with spindles that hold the back door in place. Observe the following precautions. Failure to do so may cause damage to the back door spindle, resulting in malfunction.

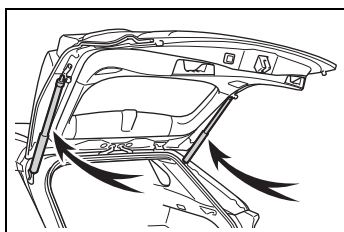

- Do not attach any foreign objects, such as stickers, plastic sheets, or adhesives to the spindle rod.
- Do not attach heavy accessories to the back door. When attaching, ask your Toyota dealer for details.
- Do not place your hand on the spindle or apply lateral forces to it.

### ■ To prevent back door closer malfunction

Do not apply excessive force to the back door while the back door closer is operating. Applying excessive force may cause the back door closer to malfunction.

### ■ To prevent damage to the power back door

- Make sure that there is no ice between the back door and frame that would prevent movement of the back door. Operating the power back door when excessive load is present on the back door may cause a malfunction.
- Do not apply excessive force to the back door while the power back door is operating.

- Take care not to damage the sensors (installed on the right and left edges of the power back door) with a knife or other sharp object. If the sensor is disconnected, the power back door will not close automatically.

## Changing settings of the power back door system (vehicles with power back door)

The settings of the power back door system can be changed by displaying the “Vehicle Settings” - “PBD” screen from the  screen of the multi-information display. (→P.94)

The changed power back door settings are not reset by turning the power switch to OFF. In order to restore the original settings, they need to be changed back on the  screen of the multi-information display.

## Adjusting the open position of the back door (vehicles with power back door)

The open position of the power back door can be adjusted.

- 1 Stop the back door in the desirable position. (→P.123)
- 2 Press and hold the power back door switch on the back door for approximately 2 seconds.

When the settings are completed, the buzzer sounds 4 times.

When opening the back door the next time, the back door will stop at that

position.

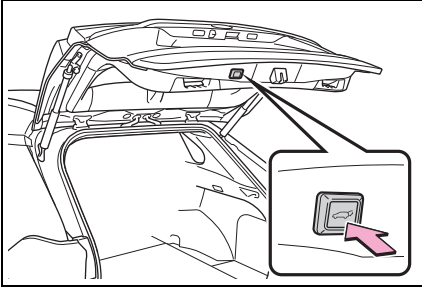

### ■ Canceling the adjusted open position of the back door

Press and hold the power back door switch on the back door for approximately 7 seconds.

After the buzzer sounds 4 times, it sounds twice more. When the power back door does the opening operation the next time, the door will open to the initial settings position.

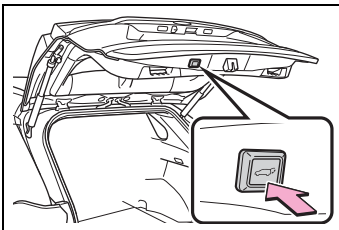

### ■ Customization

The opening position can be set with the multi-information display. (→P.94)

Priority for the stop position is given to the last position set by either the power back door switch on the back door or multi-information display.

## Smart entry & start system

The following operations can be performed simply by carrying the electronic key on your person, for example in your pocket. The driver should always carry the electronic key.

- Locks and unlocks the side doors (vehicles with entry function) (→P.115)
- Locks and unlocks the back door (vehicles with entry function) (→P.121)
- Starts the hybrid system (→P.177)

### ■ Antenna location

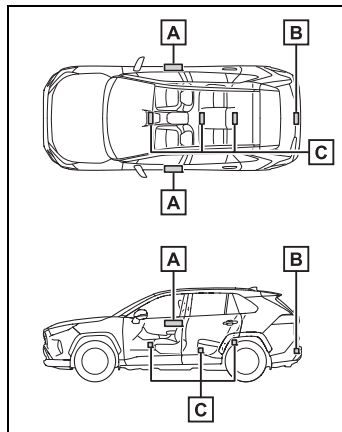

- A** Antennas outside the cabin (vehicles with entry function)
- B** Antenna outside the luggage compartment (vehicles with entry func-

tion)

**C** Antennas inside the cabin

**Effective range (areas within which the electronic key is detected)**

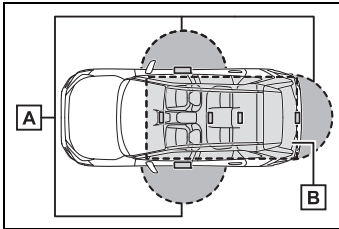

**A** When locking or unlocking the doors (vehicles with entry function)

The system can be operated when the electronic key is within about 0.7 m (2.3 ft.) of either of the outside front door handles and back door opener switch. (Only the doors detecting the key can be operated.)

**B** When starting the hybrid system or changing power switch modes

The system can be operated when the electronic key is inside the vehicle.

**If an alarm sounds or a warning message is displayed**

An alarm sounds and warning message displays shown on the multi-information display are used to protect against unexpected accidents or theft of the vehicle resulting from erroneous operation. When a warning message is displayed, take appropriate measures based on the displayed message.

When only an alarm sounds, circumstances and correction procedures are as follows.

- When an exterior alarm sounds once for 5 seconds (vehicles with entry function)

Situation	Correction procedure
An attempt was made to lock the vehicle while a door was open.	Close all of the doors and lock the doors again.

- When an interior alarm pings continuously

Situation	Correction procedure
The power switch was turned to ACC while the driver's door was open (or the driver's door was opened while the power switch was in ACC).	Turn the power switch to OFF and close the driver's door.

**Battery-saving function (vehicles with entry function)**



The battery-saving function will be activated in order to prevent the electronic key battery and the 12-volt battery from being discharged while the vehicle is not in operation for a long time.

- In the following situations, the smart entry & start system may take some time to unlock the doors.
- The electronic key has been left in an area of approximately 2 m (6 ft.) of the outside of the vehicle for 10 minutes or longer.
- The smart entry & start system has not been used for 5 days or longer.
- If the smart entry & start system has not been used for 14 days or longer, the doors cannot be unlocked at any doors except the driver's door. In this case, take hold of the driver's door handle, or use the wireless remote control or the mechanical key, to

unlock the doors.

### ■ Turning an electronic key to battery-saving mode

- When battery-saving mode is set, battery depletion is minimized by stopping the electronic key from receiving radio waves.

Press  twice while pressing and holding .

Confirm that the electronic key indicator flashes 4 times.

While the battery-saving mode is set, the smart entry & start system cannot be used. To cancel the function, press any of the electronic key buttons.

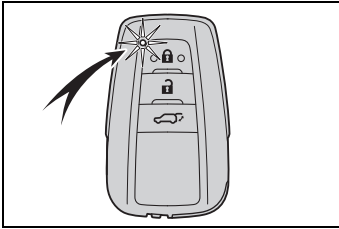

- Electronic keys that will not be used for long periods of time can be set to the battery-saving mode in advance.

### ■ When electronic key function stops

If the position of the electronic key has not changed for a certain amount of time such as when the electronic key is left somewhere, the function of the electronic key stops to reduce depletion of the battery.

In this case, function can automatically be restored by moving the position of the key such as by lifting it up.

### ■ Conditions affecting operation

The smart entry & start system uses weak radio waves. In the following situations, the communication between the electronic key and the vehicle may be affected, preventing the smart entry & start system, wireless remote control and immobilizer system from operating properly.

(Ways of coping: →P.406)

- When the electronic key battery is depleted
  - Near a TV tower, electric power plant, gas station, radio station, large display, airport or other facility that generates strong radio waves or electrical noise
  - When the electronic key is in contact with, or is covered by the following metallic objects
    - Cards to which aluminum foil is attached
    - Cigarette boxes that have aluminum foil inside
    - Metallic wallets or bags
    - Coins
    - Hand warmers made of metal
    - Media such as CDs and DVDs
  - When other wireless key (that emits radio waves) is being used nearby
  - When carrying the electronic key together with the following devices that emit radio waves
    - Portable radio, cellular phone, cordless phone or other wireless communication devices
    - Another vehicle's electronic key or a wireless key that emits radio waves
    - Personal computers or personal digital assistants (PDAs)
    - Digital audio players
    - Portable game systems
  - If window tint with a metallic content or metallic objects are attached to the rear window
  - When the electronic key is placed near a battery charger or electronic devices
  - When parking in a coin-operated parking lot (Radio waves used to detect vehicles may affect the smart entry & start system.)
- ### ■ Note for the entry function (if equipped)
- Even when the electronic key is within the effective range (detection areas), the system may not operate properly in the following cases:
    - The electronic key is too close to the

window or outside door handle, near the ground, or in a high place when the doors are locked or unlocked.

- The electronic key is on the instrument panel, luggage cover or floor, or in the door pockets or glove box when the hybrid system is started or power switch modes are changed.
  - Do not leave the electronic key on top of the instrument panel or near the door pockets when exiting the vehicle. Depending on the radio wave reception conditions, it may be detected by the antenna outside the cabin and the door will become lockable from the outside, possibly trapping the electronic key inside the vehicle.
  - As long as the electronic key is within the effective range, the doors may be locked or unlocked by anyone. However, only the doors detecting the electronic key can be used to unlock the vehicle.
  - Even if the electronic key is not inside the vehicle, it may be possible to start the hybrid system if the electronic key is near the window.
  - The doors may unlock if a large amount of water splashes on the door handle, such as in the rain or in a car wash when the electronic key is within the effective range. (The doors will automatically be locked after approximately 30 seconds if the doors are not opened and closed.)
  - If the wireless remote control is used to lock the doors when the electronic key is near the vehicle, there is a possibility that the door may not be unlocked by the entry function. (Use the wireless remote control to unlock the doors.)
  - Touching the door lock sensor while wearing gloves may delay or prevent lock operation. Remove the gloves and touch the lock sensor again.
  - When the lock operation is performed using the lock sensor, recognition signals will be shown up to two consecutive times. After this, no recognition signals will be given.
- If the door handle becomes wet while the electronic key is within the effective range, the door may lock and unlock repeatedly. In that case, follow the following correction procedures to wash the vehicle:
    - Place the electronic key in a location 2 m (6 ft.) or more away from the vehicle. (Take care to ensure that the key is not stolen.)
    - Set the electronic key to battery-saving mode to disable the smart entry & start system. (→P.131)
  - If the electronic key is inside the vehicle and a door handle becomes wet during a car wash, a message may be shown on the multi-information display and a buzzer will sound outside the vehicle. To turn off the alarm, lock all the doors.
  - The lock sensor may not work properly if it comes into contact with ice, snow, mud, etc. Clean the lock sensor and attempt to operate it again, or use the lock sensor on the lower part of the door handle.
  - A sudden approach to the effective range or door handle may prevent the doors from being unlocked. In this case, return the door handle to the original position and check that the doors unlock before pulling the door handle again.
  - If there is another electronic key in the detection area, it may take slightly longer to unlock the doors after the door handle is gripped.
- **When the vehicle is not driven for extended periods**
- Vehicles with entry function: To prevent theft of the vehicle, do not leave the electronic key within 2 m (6 ft.) of the vehicle.
  - The smart entry & start system can be deactivated in advance. (→P.434)
  - Battery-saving mode can reduce the power consumption of electronic keys. (→P.131)

### ■ To operate the system properly

Make sure to carry the electronic key when operating the system. For vehicles with entry function, do not get the electronic key too close to the vehicle when operating the system from the outside of the vehicle.

Depending on the position and holding condition of the electronic key, the key may not be detected correctly and the system may not operate properly. (The alarm may go off accidentally, or the door lock prevention may not operate.)

### ■ If the smart entry & start system does not operate properly

- Locking and unlocking the doors: Use the mechanical key. (→P.406)
- Starting the hybrid system: →P.407

### ■ Customization

Settings (e.g. smart entry & start system) can be changed.  
(Customizable features: →P.434)

If the smart entry & start system has been deactivated in a customized setting, refer to the explanations for the following operations.

- Locking and unlocking the doors: Use the wireless remote control or mechanical key. (→P.115, 406)
- Starting the hybrid system and changing power switch modes: →P.407
- Stopping the hybrid system: →P.178



### WARNING

#### ■ Caution regarding interference with electronic devices

- People with implantable cardiac pacemakers, cardiac resynchronization therapy-pacemakers or implantable cardioverter defibrillators should maintain a reasonable distance between themselves and the smart entry & start system antennas. (→P.129)

The radio waves may affect the operation of such devices. If necessary, the entry function can be disabled. Ask your Toyota dealer for details, such as the frequency of radio waves and timing of the emitted radio waves. Then, consult your doctor to see if you should disable the entry function.

- Users of any electrical medical device other than implantable cardiac pacemakers, cardiac resynchronization therapy-pacemakers or implantable cardioverter defibrillators should consult the manufacturer of the device for information about its operation under the influence of radio waves. Radio waves could have unexpected effects on the operation of such medical devices.

Ask your Toyota dealer for details on disabling the entry function.

## Front seats

The seats can be adjusted (longitudinally, vertically, etc.). Adjust the seat to ensure the correct driving posture.

## Adjustment procedure

### ▶ Manual seat

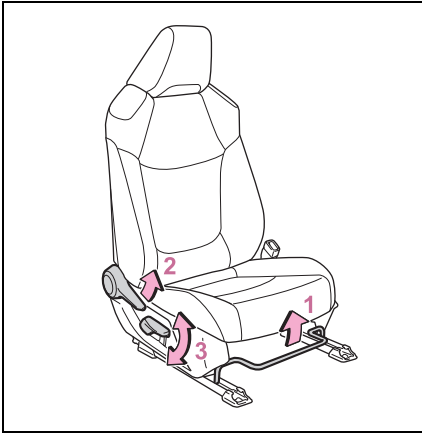

- 1 Seat position adjustment lever
- 2 Seatback angle adjustment lever
- 3 Vertical height adjustment lever (driver's side only)

### ▶ Power seat

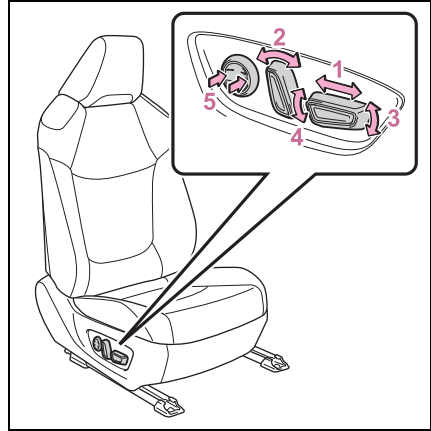

- 1 Seat position adjustment switch
- 2 Seatback angle adjustment switch
- 3 Seat cushion (front) angle adjustment switch
- 4 Vertical height adjustment switch
- 5 Lumbar support adjustment switch (driver's side only)

### ■ When adjusting the seat

Take care when adjusting the seat so that the head restraint does not touch the ceiling and sun visor.

### ⚠ WARNING

#### ■ When adjusting the seat position

- Take care when adjusting the seat position to ensure that other passengers are not injured by the moving seat.
- Do not put your hands under the seat or near the moving parts to avoid injury. Fingers or hands may become jammed in the seat mechanism.



### WARNING

- Make sure to leave enough space around the feet so they do not get stuck.
- Manual seat only: After adjusting the seat, make sure that the seat is locked in position.

#### ■ Seat adjustment

To reduce the risk of sliding under the lap belt during a collision, do not recline the seat more than necessary. If the seat is too reclined, the lap belt may slide past the hips and apply restraint forces directly to the abdomen, or your neck may contact the shoulder belt, increasing the risk of death or serious injury in the event of an accident.

Adjustments should not be made while driving as the seat may unexpectedly move and cause the driver to lose control of the vehicle.

## Rear seats

**Reclining adjustments and folding the seatbacks can be done with lever operation.**

### Adjustment procedure

Pull the seatback angle adjustment lever **A**, and adjust the seatback angle.

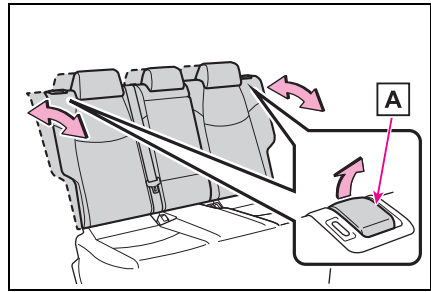

### WARNING

#### ■ When operating the seatback

Observe the following precautions. Failure to do so may cause death or serious injury.

- Keep other passengers from being hit with the seatback.
- Do not bring your hands close to the moving parts or between the seats, as well as do not let any part of your body get caught.

### ⚠ WARNING

- After adjusting the seat, make sure that the seat is locked in position. If the seatback is not securely locked, the red marking will be visible. Make sure that the red marking is not visible.

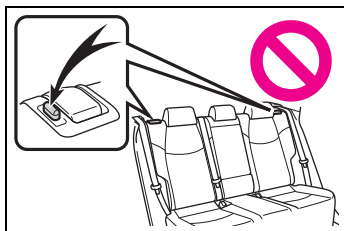

### Folding down the rear seatbacks

#### ■ Before folding down the seatbacks

- 1 Park the vehicle in a safe place.

Apply the parking brake (→P.187) and shift the shift lever to P. (→P.184)

- 2 Adjust the position of the front seat and the angle of the seatback. (→P.134)

Depending on the position of the front seat, if the seatback is folded backward, it may interfere with the operation of the rear seat.

- 3 Lower the head restraint of the rear seat. (→P.140)
- 4 Stow the armrest of the rear seat if it is pulled out. (→P.325)

This step is not necessary when operating the left side seat only.

#### ■ Folding down the seatbacks

While pulling the seatback angle adjustment lever **A**, fold the seatback down.

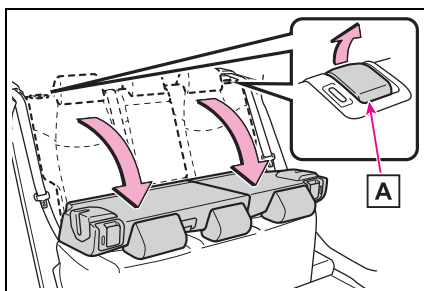

#### ■ Returning the rear seatbacks

To avoid trapping the seat belt between the seat and the inside of the vehicle, pass the seat belt outside the seat belt guide **A** and then return the seatback securely to the locked position.

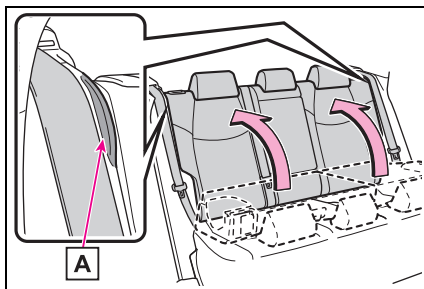

### ⚠ WARNING

Observe the following precautions. Failure to do so may result in death or serious injury.

#### ■ When folding the rear seatbacks down

- Do not fold the seatbacks down while driving.
- Stop the vehicle on level ground, set the parking brake and shift the shift lever to P.
- Do not allow anyone to sit on a folded seatback or in the luggage compartment while driving.

## ⚠ WARNING

- Do not allow children to enter the luggage compartment.
- Do not operate the rear seat if it is occupied.
- Be careful not to get feet or hands caught in the moving parts or joints of the seats during operation.
- Do not allow children to operate the seat.
- **After returning the rear seatback to the upright position**
- Make sure that the seatback is securely locked in position by lightly pushing it back and forth. If the seatback is not securely locked, the red marking will be visible. Make sure that the red marking is not visible.

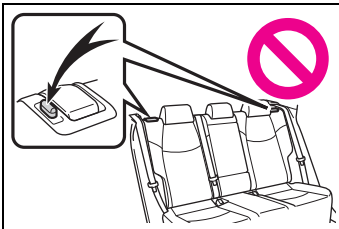

- Check that the seat belts are not twisted or caught in the seatback.

## Driving position memory\*

\*: If equipped

**This feature automatically adjusts the driver's seat to suit your preferences.**

**Your preferred driving position (the position of the driver's seat) can be recorded and recalled by pressing a button.**

**Two different driving positions can be recorded into memory.**

**Each electronic key can be registered to recall your preferred driving position.**

## Recording/recalling a driving position

### ■ Recording procedure

- 1 Check that the shift lever is in P.
- 2 Turn the power switch to ON.
- 3 Adjust the driver's seat to the desired positions.
- 4 While pressing the "SET" button, or within 3 seconds after the "SET" button is pressed, press button "1" or "2" until the buzzer sounds.

If the selected button has already been preset, the previously recorded position

will be overwritten.

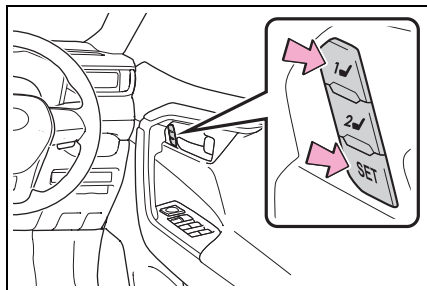

**■ Recall procedure**

- 1 Check that the shift lever is in P.
- 2 Turn the power switch to ON.
- 3 Press one of the buttons for the driving position you want to recall until the buzzer sounds.

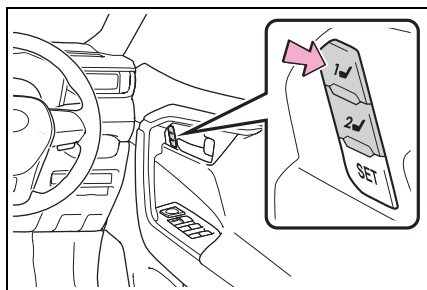

**■ To stop the position recall operation part-way through**

Perform any of the following:

- Press the “SET” button.
- Press button “1” or “2”.
- Operate any of the seat adjustment switches.

**■ Seat positions that can be memorized (→P.134)**

The adjusted positions other than the position adjusted by lumbar support switch can be recorded.

**■ Operating the driving position memory after turning the power switch to OFF**

Recorded seat positions can be activated up to 180 seconds after the driver's door is opened and another 60 seconds after it is closed again.

**■ In order to correctly use the driving position memory function**

If a seat position is already in the furthest possible position and the seat is operated in the same direction, the recorded position may be slightly different when it is recalled.

**■ When recalling the driving position**

Take care when recalling the driving position so that the head restraint does not touch the ceiling.

**■ If the 12-volt battery is disconnected**

The memorized positions are erased.

**■ When the recorded seat position cannot be recalled**

The seat position may not be recalled in some situations when the seat position is recorded in a certain range. For details, contact your Toyota dealer.

**▲ WARNING**

**■ Seat adjustment caution**

Take care during seat adjustment so that the seat does not strike the rear passenger or squeeze your body against the steering wheel.

**Registering/recall/canceling an electronic key to driving position (memory recall function)**

**■ Registering procedure**

Record your driving position to button “1” or “2” before performing the following:

Carry only the key you want to register, and then close the driver's door.

If 2 or more keys are in the vehicle, the driving position cannot be recorded properly.

- 1 Check that the shift lever is in P.
- 2 Turn the power switch to ON.
- 3 Recall the driving position that you want to record.
- 4 While pressing the recalled button, press and hold the door lock switch (either lock or unlock) until the buzzer sounds.

If the button could not be registered, the buzzer sounds continuously for approximately 3 seconds.

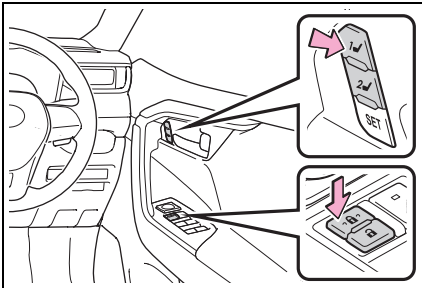

### ■ Recall procedure

Make sure that the doors are locked before recalling the driving position. Carry the electronic key that has been registered to the driving position, and then unlock and open the driver's door using the smart entry & start system or wireless remote control.

The driving position will move to the recorded position.

If the driving position is in a position

that has already been recorded, the seat will not move.

### ■ Cancellation procedure

Carry only the key you want to cancel and then close the driver's door. If 2 or more keys are in the vehicle, the driving position cannot be canceled properly.

- 1 Check that the shift lever is in P.
- 2 Turn the power switch to ON.
- 3 While pressing the "SET" button, press and hold the door lock switch (either lock or unlock) until the buzzer sounds twice.

If the button could not be canceled, the buzzer sounds continuously for approximately 3 seconds.

### ■ Recalling the driving position using the memory recall function

- Different driving positions can be registered for each electronic key. Therefore, the driving position that is recalled may be different depending on the key being carried.
- If a door other than the driver's door is unlocked with the smart entry & start system, the driving position cannot be recalled. In this case, press the driving position button which has been set.

### ■ Customization

Settings (e.g. the unlock door settings of the memory recall function) can be customized. (Customizable features: →P.436)

## Head restraints

Head restraints are provided for all seats.

### WARNING

#### Head restraint precautions

Observe the following precautions regarding the head restraints. Failure to do so may result in death or serious injury.

- Use the head restraints designed for each respective seat.
- Adjust the head restraints to the correct position at all times.
- After adjusting the head restraints, push down on them and make sure they are locked in position.
- Do not drive with the head restraints removed.

## Vertical adjustment

### Front seats

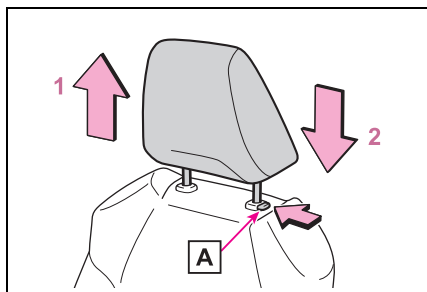

#### 1 Up

Pull the head restraints up.

#### 2 Down

Push the head restraint down while pressing the lock release button **A**.

### Rear seats

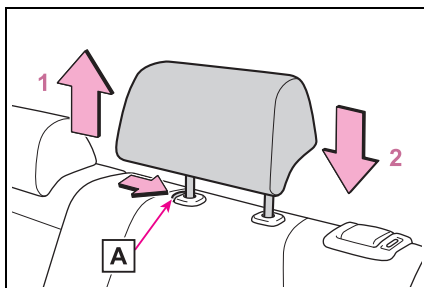

#### 1 Up

Pull the head restraints up.

#### 2 Down

Push the head restraint down while pressing the lock release button **A**.

### Adjusting the height of the head restraints (front seats)

Make sure that the head restraints are adjusted so that the center of the head restraint is closest to the top of your ears.

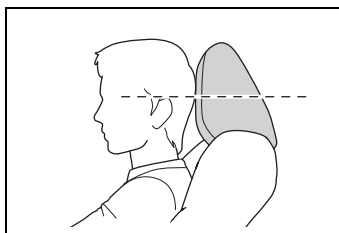

### Adjusting the rear seat head restraint

Always raise the head restraint one level from the stowed position when using.

## Removing the head restraints

Pull the head restraint up while pressing the lock release button

**A**.

If the head restraint touches the ceiling, making the removal difficult, change the seat height or angle. (→P.134)

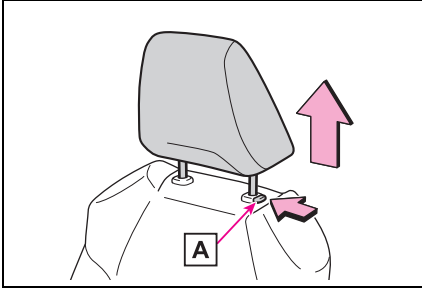

### Installing the head restraints

Align the head restraint with the installation holes and push it down to the lock position.

Press and hold the lock release

button **A** when lowering the head restraint.

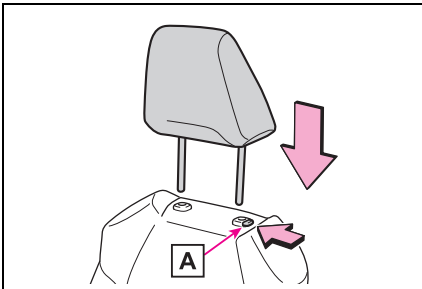

## Steering wheel

### Adjustment procedure

- 1 Hold the steering wheel and push the lever down.

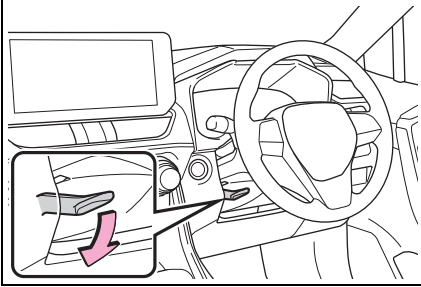

- 2 Adjust to the ideal position by moving the steering wheel horizontally and vertically.

After adjustment, pull the lever up to secure the steering wheel.

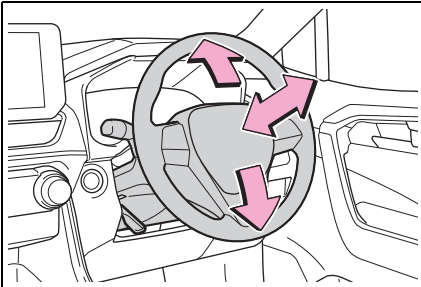

### WARNING

#### ■ Caution while driving

Do not adjust the steering wheel while driving.

Doing so may cause the driver to mishandle the vehicle and cause an accident, resulting in death or serious injury.

#### ■ After adjusting the steering wheel

Make sure that the steering wheel is securely locked.

Otherwise, the steering wheel may move suddenly, possibly causing an accident, and resulting in death or serious injury. Also, the horn may not sound if the steering wheel is not securely locked.

### Sounding the horn

To sound the horn, press on or close to the  mark.

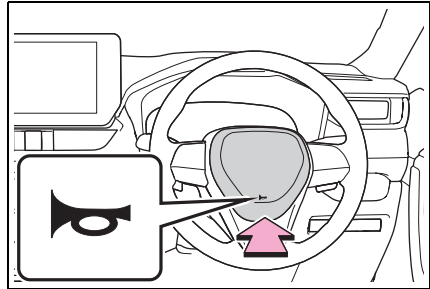



## Inside rear view mirror\*

\*: If equipped

The rear view mirror's position can be adjusted to enable sufficient confirmation of the rear view.

## Adjusting the height of rear view mirror

The height of the rear view mirror can be adjusted to suit your driving posture.

Adjust the height of the rear view mirror by moving it up and down.

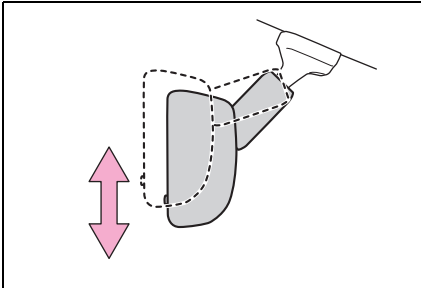

### WARNING

#### Caution while driving

Do not adjust the position of the mirror while driving. Doing so may lead to mishandling of the vehicle and cause an accident, resulting in death or serious injury.

## Anti-glare function

- ▶ Manual anti-glare inside rear view mirror

Reflected light from the headlights of vehicles behind can be reduced

by operating the lever.

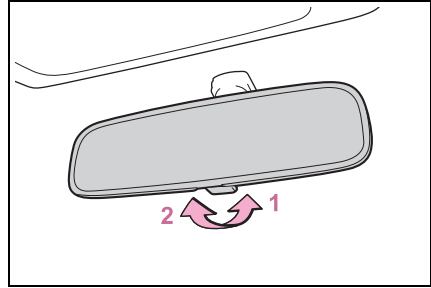

1 Normal position

2 Anti-glare position

- ▶ Auto anti-glare inside rear view mirror

Responding to the level of brightness of the headlights of vehicles behind, the reflected light is automatically reduced.

Changing automatic anti-glare function mode on/off

When the automatic anti-glare function is in ON mode, the indicator **A** illuminates.

The function will set to ON mode each time the power switch is turned to ON. Pressing the button turns the function to OFF mode. (The indicator **A** also turns off.)

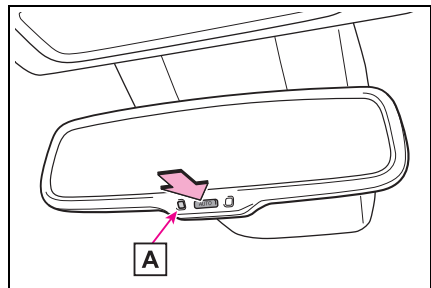

- To prevent sensor error (vehicles with auto anti-glare inside rear view mirror)

To ensure that the sensors operate properly, do not touch or cover them.

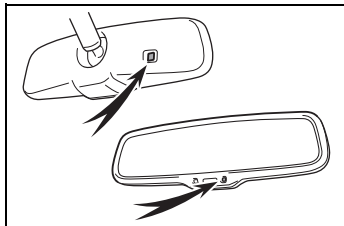

## Digital Rear-view Mirror\*

\*: If equipped

The Digital Rear-view Mirror is a system that uses the camera on the rear of the vehicle and displays its image on the display of the Digital Rear-view Mirror.

The Digital Rear-view Mirror can be changed between optical mirror mode and digital mirror mode by operating the lever.

The Digital Rear-view Mirror allows the driver to see the rear view despite obstructions, such as the head restraints or luggage, ensuring rear visibility. Also, the rear seats are not displayed and privacy of the passengers is enhanced.

### WARNING

Observe the following precautions. Failure to do so may result in death or serious injury.

#### ■ Before using the Digital Rear-view Mirror

- Make sure to adjust the mirror before driving. (→P.146)
- Change to optical mirror mode and adjust the position of the Digital Rear-view Mirror so that the area behind your vehicle can be viewed properly.
- Change to digital mirror mode and adjust the display settings.

### ⚠ WARNING

- As the range of the image displayed by the Digital Rear-view Mirror is different from that of the optical mirror, make sure to check this difference before driving.

## System components

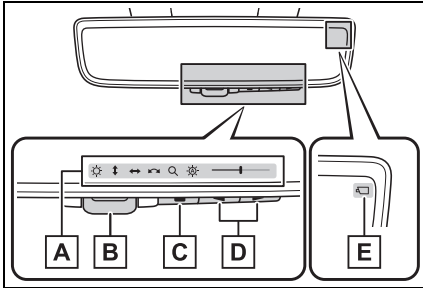

### A Icon display area

Displays icons, adjusting gauge, etc.  
(→P.146)

### B Lever

Operate to change between digital mirror mode and optical mirror mode.

### C Menu button

Press to display the icon display area and select the item you want to adjust.

### D Select/adjust button

Press to change the setting of the item you want to adjust.

### E Camera indicator

Indicates that the camera is operating normally.

## Changing modes

Operate the lever to change between digital mirror mode and optical mirror mode.

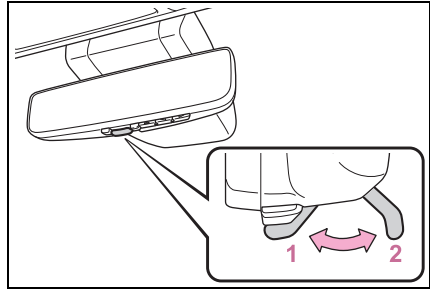

### 1 Digital mirror mode

Displays an image of the area behind the vehicle.

 will illuminate in this mode.

### 2 Optical mirror mode

Turns off the display of the Digital Rear-view Mirror allows it to be used as an optical mirror.

### ■ Digital mirror mode operating condition

The power switch is turned to ON.

When the power switch is changed from ON to OFF or ACC, the image will disappear after several seconds.

### ■ When using the Digital Rear-view Mirror in digital mirror mode

- If it is difficult to see the displayed image due to light reflected off the Digital Rear-view Mirror, the camera being dirty or covered with water droplets, or if lights of a vehicle behind your vehicle or the displayed image are bothering you, change to optical mirror mode.
- When the back door is open, the Digital Rear-view Mirror image may not display properly. Before driving, make sure the back door is closed.
- If the display is difficult to see due to reflected light, close the electronic sunshade for the moon roof (if equipped).
- Any of the following conditions may occur when driving in the dark, such

as at night. None of them indicates that a malfunction has occurred.

- Colors of objects in the displayed image may differ from their actual color.
- Depending on the height of the lights of the vehicle behind, the area around the vehicle may appear white and blurry.
- Automatic image adjustment for brighter surrounding image may cause flickering.

If it is difficult to see the displayed image or flickering bothers you, change to optical mirror mode.

- The Digital Rear-view Mirror may become hot while it is in digital mirror mode. This is not a malfunction.
- Depending on your physical condition or age, it may take longer than usual to focus on the displayed image. In this case, change to optical mirror mode.
- Do not let passengers stare at the displayed image when the vehicle is being driven, as doing so may cause motion sickness.

#### ■ When the system malfunctions

If the symbol shown in the illustration is displayed when using the Digital Rear-view Mirror in digital mirror mode, the system may be malfunctioning. The symbol will disappear in a few seconds. Operate the lever, change to optical mirror mode and have the vehicle inspected by your Toyota dealer.

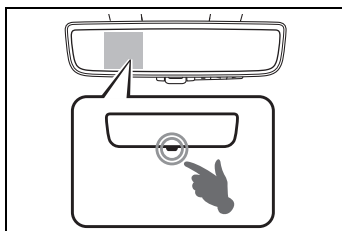

## Adjusting the mirror

### ■ Adjusting the mirror height

The height of the rear view mirror can be adjusted to suit your driving posture.

Change to optical mirror mode, adjusting the height of the rear view mirror by moving it up and down.

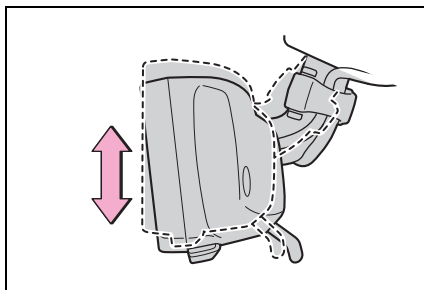

### ■ Display settings (digital mirror mode)



Settings of the display in the digital mirror mode, on/off operation of the automatic anti-glare function, etc. can be changed.

#### 1 Press the menu button.

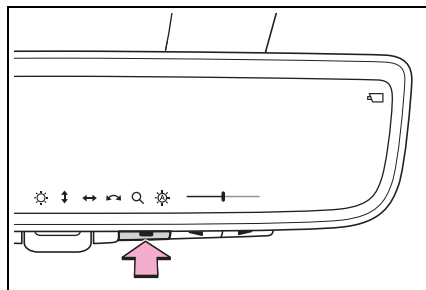





The icons will be displayed.



#### 2 Press the menu button repeatedly and select the item you want to adjust.

- 3 Press  or  to change the setting.

The icons will disappear if a button is not operated for approximately 5 seconds or more.

Icons	Settings
	Select to adjust the brightness of the display.
	Select to adjust the area displayed up/down.
	Select to adjust the area displayed to the left/right.
	Select to adjust the angle of the displayed image.
	Select to zoom in/out the displayed image.
	Select to enable/disable the automatic anti-glare function.* Responding to the brightness of the headlights of vehicles behind, the reflected light is automatically adjusted. The automatic anti-glare function is enabled each time the power switch is changed to ON.

\*: This is a function for the optical mirror mode, however, the setting can also be changed while using the digital mirror mode.

### ■ Enabling/disabling the automatic anti-glare function (optical mirror mode)

The automatic anti-glare function in the optical mirror mode can be enabled/disabled. The setting can be changed in both the digital mir-

ror mode and the optical mirror mode.

- ▶ When using the digital mirror mode



→P.146

- ▶ When using the optical mirror mode

- 1 Press the menu button.

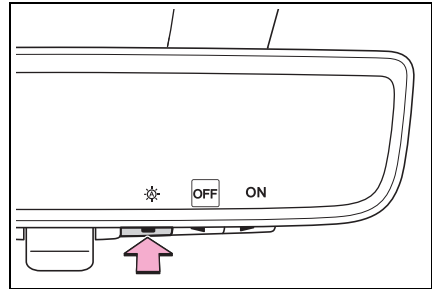
The icons will be displayed.



- 2 Press  or  to enable (ON)/disable (OFF) the automatic anti-glare function.

The icons will disappear if a button is not operated for approximately 5 seconds or more.

### ■ Adjusting the display (digital mirror mode)

- If the displayed image is adjusted, it may appear distorted. This is not a malfunction.
- If the brightness of the Digital Rear-view Mirror is set too high, it may cause eye strain. Adjust the Digital Rear-view Mirror to an appropriate brightness. If your eyes become tired, change to optical mirror mode.
- The brightness of the Digital Rear-view Mirror will change automatically according to the brightness of the area in front of your vehicle.

### ■ To prevent the light sensors from malfunctioning

To prevent the light sensors from malfunctioning, do not touch or cover them.

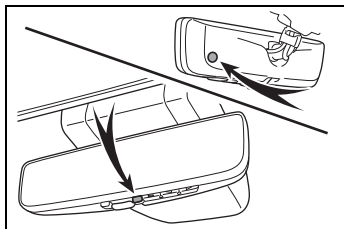

### ⚠ WARNING

Observe the following precautions. Failure to do so may result in death or serious injury.

#### ■ While driving

- Do not adjust the position of the Digital Rear-view Mirror or adjust the display settings while driving. Stop the vehicle and operate the Digital Rear-view Mirror control switches. Failure to do so may cause a steering wheel operation error, resulting in an unexpected accident.

- Always pay attention to the vehicle's surroundings.

The size of the vehicles and other objects may look different when in digital mirror mode and optical mirror mode.

When backing up, make sure to directly check the safety of the area around your vehicle, especially behind the vehicle.

Additionally, if a vehicle approaches from the rear in the dark, such as at night, the surrounding area may appear dim.

### ■ To prevent causes of fire

If the driver continues using the Digital Rear-view Mirror while smoke or odor comes from the mirror, it may result in fire. Stop using the system immediately and contact your Toyota dealer.

## Cleaning the Digital Rear-view Mirror

### ■ Cleaning the mirror surface

If the mirror surface is dirty, the image on the display may be difficult to see.

Clean the mirror surface gently using a soft dry cloth.

### ■ Cleaning the camera

If the camera lens is dirty, the displayed image may not be clear. In this case, clean it with a soft cloth dampened with water or a swab.

### ■ The camera

The camera for the Digital Rear-view Mirror is located as shown.

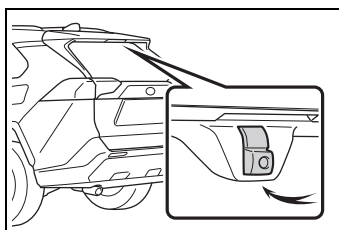

### ■ The cooling fan

There is a cooling fan in the Digital Rear-view Mirror. Cooling fan sounds may be heard when using the system.



## NOTICE

■ **To prevent the Digital Rear-view Mirror from malfunctioning**

- Do not use detergents, such as thinner, benzene, and alcohol to clean the mirror. They may discolor, deteriorate or damage the mirror surface.
- Do not smoke, use matches, use cigarette lighters or allow open flames near the mirror. It may damage the mirror or cause a fire.
- Do not remove, disassemble or modify the mirror.

■ **To prevent the camera from malfunctioning**

- Observe the following precautions, otherwise the Digital Rear-view Mirror may not operate properly.
  - Do not strike or hit the camera or subject it to a strong impact, as the camera installation position and angle may be changed.
  - Do not remove, disassemble or modify the camera.
  - Do not allow an organic solvent, car wax, window cleaner or glass coating to adhere to the camera. If this happens, wipe it off as soon as possible.
  - When cleaning the camera lens, wipe the camera lens with a damp soft cloth. Do not strongly rub the camera lens, as it may be scratched and will not be able to transmit a clear image.
  - When applying colored film (including transparent film) to the rear window glass, do not apply it to the area in front of the camera. If film is applied to the area in front of the camera, the image from the camera may not display properly.

- Do not subject the camera to a strong impact as this could cause a malfunction. If this happens, have the vehicle inspected by your Toyota dealer as soon as possible.
- Do not block the vent holes of the mirror. Otherwise, the mirror may be hot, leading to a malfunction or a fire.

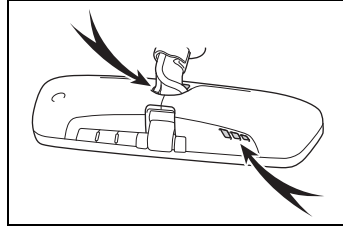



### If you notice any symptoms



If you notice any of the following symptoms, refer to the following table for the likely cause and the solution.

If the symptom is not resolved by the solution, have the vehicle inspected by your Toyota dealer.

Symptom	Likely cause	Solution
The image is difficult to see.	The mirror surface is dirty.	Clean the mirror surface gently, using a soft dry cloth.
	Sunlight or headlights are shining directly into the Digital Rear-view Mirror.	Change to optical mirror mode. (If the light is coming through the moon roof [if equipped].)
	<ul style="list-style-type: none"> <li>• The vehicle is in a dark area.</li> <li>• The vehicle is near a TV tower, broadcasting station, electric power plant, or other location where strong radio waves or electrical noise may be present.</li> <li>• The temperature around the camera is extremely high/low.</li> <li>• The ambient temperature is extremely low.</li> <li>• It is raining or humid.</li> <li>• Sunlight or headlights are shining directly into the camera lens.</li> <li>• The vehicle is under fluorescent lights, sodium lights, mercury lights, etc.</li> <li>• Exhaust gas is obstructing the camera.</li> </ul>	Change to optical mirror mode. (Change back to digital mirror mode when the conditions have improved.)
	Foreign matters such as water droplets or dust is on the camera lens.	Wipe the camera lens with a damp soft cloth.



Symptom	Likely cause	Solution
The image is difficult to see.	The luggage in the luggage compartment is reflected off the rear window glass and obstructing the camera.	<ul style="list-style-type: none"> <li>• Change to optical mirror mode.</li> <li>• Move the luggage to a position where it does not obstruct the camera or cover it with a black cloth to reduce the amount it is reflected off the rear window glass.</li> </ul>
	The rear window glass is fogged up.	Change to optical mirror mode. After defogging the rear window using the rear window defogger (→P.300), use the digital mirror mode again.
	The outside of the rear window glass is dirty.	Use the rear window wiper to remove dirt.
	The inside of the rear window glass is dirty.	Wipe the inside of rear window glass with a damp soft cloth.
The image is out of alignment.	The back door is not fully closed.	Fully close the back door.
	The camera or its surrounding area has received a strong impact.	Change to optical mirror mode and have the vehicle inspected by your Toyota dealer.
The display is dim and  is displayed.	The system may be malfunctioning.	Change to optical mirror mode and have the vehicle inspected by your Toyota dealer.
 goes off.		

Symptom	Likely cause	Solution
 is displayed.	The Digital Rear-view Mirror is extremely hot. (The display will gradually become more dim. If the temperature continues to increase, the Digital Rear-view Mirror will turn off.)	Reducing the cabin temperature is recommended to reduce the temperature of the mirror. (  will disappear when the mirror becomes cool.) If  does not disappear even though the mirror is cool, have the vehicle inspected by your Toyota dealer.
The lever cannot be operated properly.	The lever may be malfunctioning.	Change to optical mirror mode and have the vehicle inspected by your Toyota dealer. (To change to optical mirror mode, press and hold the menu button for approximately 10 seconds.)

## Outside rear view mirrors

The rear view mirror's position can be adjusted to enable sufficient confirmation of the rear view.

### ■ When using the outside rear view mirrors in a cold weather

When it is cold and the outside rear view mirrors are frozen, it may not be possible to fold/extend them or adjust the mirror surface. Remove the ice, snow, etc. covering the outside rear view mirrors.

### ■ Defogging the mirrors

The outside rear view mirrors can be cleared using the mirror defoggers. Turn on the rear window defogger to turn on the outside rear view mirror defoggers. (→P.300)

### ⚠ WARNING

#### ■ Important points while driving

Observe the following precautions while driving. Failing to do so may result in loss of control of the vehicle and cause an accident, resulting in death or serious injury.

- Do not adjust the mirrors while driving.
- Do not drive with the mirrors folded.
- Both the driver and passenger side mirrors must be extended and properly adjusted before driving.

#### ■ When the mirror defoggers are operating

Do not touch the rear view mirror surfaces, as they can become very hot and burn you.

## Adjustment procedure

- 1 To select a mirror to adjust, press the switch.

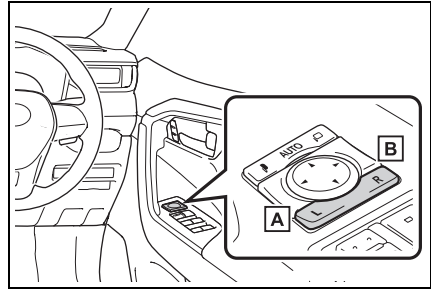

A Left

B Right

- 2 To adjust the mirror, press the switch.

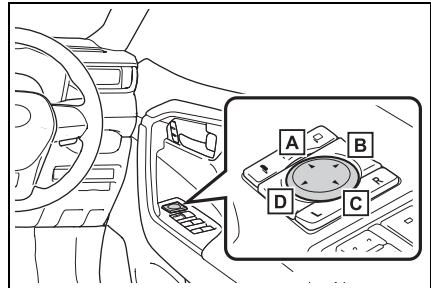

A Up

B Right

C Down

D Left

### ■ Mirror angle can be adjusted when

The power switch is in ACC or ON.

## Folding the mirrors

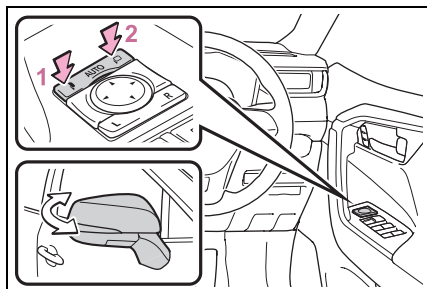

- 1 Folds the mirrors
- 2 Extends the mirrors

Vehicles with automatic mode: Putting the outside rear view mirror folding switch in the neutral position sets the mirrors to automatic mode. Automatic mode allows the folding or extending of the mirrors to be linked to locking/unlocking of the doors.

### ■ Customization (vehicles with automatic mode)

The automatic mirror folding and extending operation can be changed. (Customizable features: →P.436)



### WARNING

#### ■ When a mirror is moving

To avoid personal injury and mirror malfunction, be careful not to get your hand caught by the moving mirror.

## Power windows

### Opening and closing the power windows

The power windows can be opened and closed using the switches.

Operating the switch moves the side windows as follows:

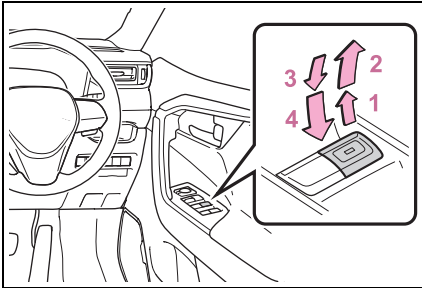

- 1 Closing
- 2 One-touch closing\*
- 3 Opening
- 4 One-touch opening\*

\*: To stop the side window partway, operate the switch in the opposite direction.

#### ■ The power windows can be operated when

The power switch is in ON.

#### ■ Operating the power windows after turning the hybrid system off

The power windows can be operated for approximately 45 seconds even after the power switch is turned to ACC or OFF. They cannot, however, be operated once either front door is opened.

#### ■ Jam protection function

If an object becomes jammed between the side window and the window frame while the side window is closing, side

window movement is stopped and the side window is opened slightly.

#### ■ Catch protection function

If an object becomes caught between the door and side window while the side window is opening, side window movement is stopped.

#### ■ When the power window cannot be opened or closed

When the jam protection function or catch protection function operates unusually and the side window cannot be opened and closed, perform the following operations with the power window switch of that door.

- Stop the vehicle. With the power switch in ON, within 4 seconds of the jam protection function or catch protection function activating, continuously operate the power window switch in the one-touch closing direction or one-touch opening direction so that the side window can be opened and closed.
- If the side window cannot be opened and closed even when performing the above operations, perform the following procedure for function initialization.
  - 1 Turn the power switch to ON.
  - 2 Pull and hold the power window switch in the one-touch closing direction and completely close the side window.
  - 3 Release the power window switch for a moment, resume pulling the switch in the one-touch closing direction, and hold it there for approximately 6 seconds or more.
  - 4 Press and hold the power window switch in the one-touch opening direction. After the side window is completely opened, continue holding the switch for an additional 1 second or more.
  - 5 Release the power window switch for a moment, resume pushing the switch in the one-touch opening

direction, and hold it there for approximately 4 seconds or more.

- 6 Pull and hold the power window switch in the one-touch closing direction again. After the side window is completely closed, continue holding the switch for a further 1 second or more.

If you release the switch while the side window is moving, start again from the beginning.

If the side window reverses and cannot be fully closed or opened, have the vehicle inspected by your Toyota dealer.

#### ■ Door lock linked power window operation

- The power windows can be opened and closed using the mechanical key.\* (→P.407)
- The power windows can be opened and closed using the wireless remote control.\* (→P.115)

\*: These settings must be customized at your Toyota dealer.

#### ■ Power window open reminder function

The buzzer sounds and a message is shown on the multi-information display when the power switch is turned to OFF and the driver's door is opened with the power windows open.

#### ■ Customization

Settings (e.g. linked door lock operation) can be changed. (Customizable features: →P.436)



#### WARNING

Observe the following precautions. Failing to do so may result in death or serious injury.

#### ■ Closing the power windows

- The driver is responsible for all the power window operations, including the operation for the passengers. In order to prevent accidental operation, especially by a child, do not let a child operate the power windows. It is possible for children and other passengers to have body parts caught in the power window. Also, when riding with a child, it is recommended to use the window lock switch. (→P.157)
- Check to make sure that all passengers do not have any part of their body in a position where it could be caught when a power window is being operated.

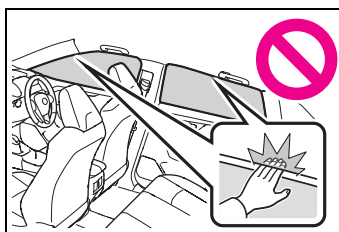

- When using the wireless remote control or mechanical key and operating the power windows, operate the power window after checking to make sure that there is no possibility of any passenger having any of their body parts caught in the side window. Also, do not let a child operate the power window by the wireless remote control or mechanical key. It is possible for children and other passengers to get caught in the power window.
- When exiting the vehicle, turn the power switch to OFF, carry the key and exit the vehicle along with the child. There may be accidental operation, due to mischief, etc., that may possibly lead to an accident.

**WARNING**
**Jam protection function**

- Never use any part of your body to intentionally activate the jam protection function.
- The jam protection function may not work if something gets jammed just before the side window is fully closed. Be careful not to get any part of your body jammed in the side window.

**Catch protection function**

- Never use any part of your body or clothing to intentionally activate the catch protection function.
- The catch protection function may not work if something gets caught just before the side window is fully opened. Be careful not to get any part of your body or clothing caught in the side window.

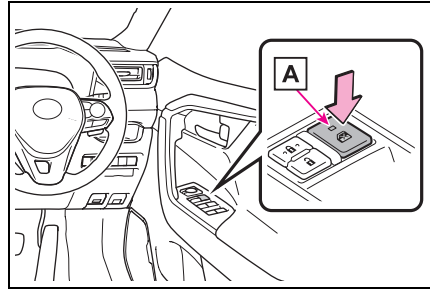
**The window lock switch can be operated when**

The power switch is in ON.

**When the 12-volt battery is disconnected**

The window lock switch is disabled. If necessary, press the window lock switch after reconnecting the 12-volt battery.

**Preventing accidental operation (window lock switch)**

This function can be used to prevent children from accidentally opening or closing a passenger window.

Press the switch.

The indicator **A** will come on and the passenger windows will be locked.

The passenger windows can still be opened and closed using the driver's switch even if the lock switch is on.

## Moon roof\*

\*: If equipped

**Use the overhead switches to open and close the moon roof and tilt it up and down.**

## Operating the moon roof

### ■ Opening and closing

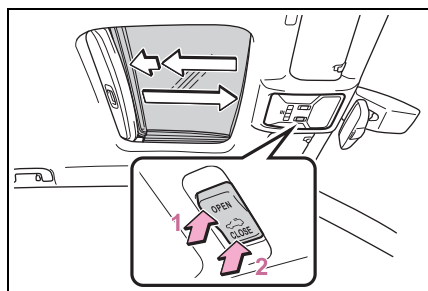

#### 1 Opens the moon roof\*

The moon roof stops slightly before the fully open position to reduce wind noise.

Press the switch again to fully open the moon roof.

#### 2 Closes the moon roof\*

\*: Lightly press either side of the moon roof switch to stop the moon roof partway.

### ■ Tilting up and down

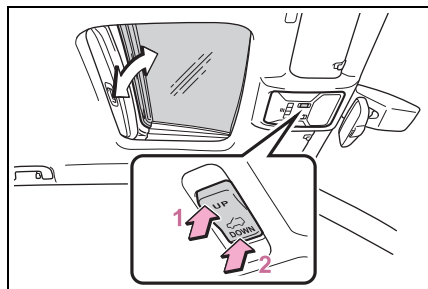

#### 1 Tilts the moon roof up\*

#### 2 Tilts the moon roof down\*

\*: Lightly press either side of the moon roof switch to stop the moon roof partway.

### ■ The moon roof can be operated when

The power switch is in ON.

### ■ Operating the moon roof after turning the hybrid system off

The moon roof can be operated for approximately 45 seconds after the power switch is turned to ACC or OFF. It cannot, however, be operated once either front door is opened.

### ■ Jam protection function

If an object is detected between the moon roof and the frame while the moon roof is closing or tilting down, travel is stopped and the moon roof opens slightly.

### ■ Sunshade

The sunshade can be opened and closed manually. However, the sunshade will open automatically when the moon roof is opened.

### ■ Door lock linked moon roof operation

- The moon roof can be opened and closed using the mechanical key.\* (→P.407)
- The moon roof can be opened and closed using the wireless remote control.\* (→P.115)

\*: These settings must be customized at your Toyota dealer.

### ■ When the moon roof does not close normally

Perform the following procedure:

- 1 Stop the vehicle.
- 2 Press and hold the "CLOSE" switch.\* The moon roof will close, reopen and



pause for approximately 10 seconds. Then it will close again and stop at the completely closed position.

**3** Check to make sure that the moon roof is completely closed and then release the switch.

\*: If the switch is released at the incorrect time, the procedure will have to be performed again from the beginning.

If the moon roof does not fully close even after performing the above procedure correctly, have the vehicle inspected by your Toyota dealer.

#### ■ If the moon roof does not move normally

If the moon roof does not open or close normally or the automatic opening function does not operate, perform the following initialization procedure.

**1** Stop the vehicle.

**2** Press and hold the "DOWN" switch.\*

The moon roof will stop at the tilt-up position. After that, it will open, close, tilt up, tilt down, and stop at the fully closed position.

**3** Confirm that the moon roof has completely stopped and release the switch.

\*: If you release the switch while the moon roof is moving, perform the procedure again from the beginning.

If, after performing the above procedures correctly, the moon roof still does not open or close normally or the automatic opening function does not operate, have the vehicle inspected by your Toyota dealer.

#### ■ Moon roof open reminder function

The buzzer sounds and a message is shown on the multi-information display when the power switch is turned to OFF and the driver's door is opened with the moon roof open.

#### ■ Customization

Settings (e.g. linked door lock operation) can be changed. (Customizable features: →P.436)

#### ⚠ WARNING

Observe the following precautions. Failure to do so may cause death or serious injury.

#### ■ Opening the moon roof

● Do not allow any passengers to put their hands or head outside the vehicle while it is moving.

● Do not sit on top of the moon roof.

#### ■ Opening and closing the moon roof

● The driver is responsible for moon roof opening and closing operations.

In order to prevent accidental operation, especially by a child, do not let a child operate the moon roof. It is possible for children and other passengers to have body parts caught in the moon roof.

● Check to make sure that all passengers do not have any part of their body in a position where it could be caught when the moon roof is being operated.

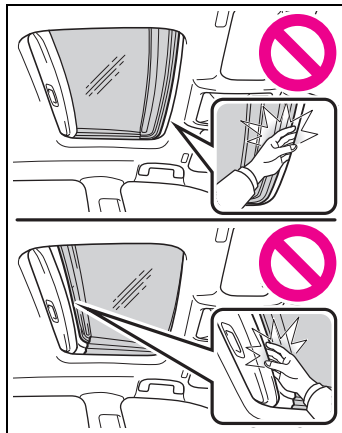

**WARNING**

- When using the wireless remote control or mechanical key and operating the moon roof, operate the moon roof after checking to make sure that there is no possibility of any passenger having any of their body parts caught in the moon roof. Also, do not let a child operate moon roof by the wireless remote control or mechanical key. It is possible for children and other passengers to get caught in the moon roof.
  - When exiting the vehicle, turn the power switch to OFF, carry the key and exit the vehicle along with the child. There may be accidental operation, due to mischief, etc., that may possibly lead to an accident.
- **Jam protection function**
- Never use any part of your body to intentionally activate the jam protection function.
  - The jam protection function may not work if something gets caught just before the moon roof is fully closed. Also, the jam protection function is not designed to operate while the switch is being pressed. Take care so that your fingers, etc. do not get caught.

**4-1. Before driving**

Driving the vehicle .....	<b>162</b>
Cargo and luggage .....	<b>168</b>
Trailer towing (except Australia and New Zealand) .....	<b>169</b>
Trailer towing (for Australia and New Zealand) .....	<b>170</b>

**4-2. Driving procedures**

Power (ignition) switch.....	<b>177</b>
EV drive mode .....	<b>181</b>
Hybrid transmission .....	<b>183</b>
Turn signal lever .....	<b>186</b>
Parking brake .....	<b>187</b>
Brake Hold.....	<b>191</b>

**4-3. Operating the lights and wipers**

Headlight switch .....	<b>193</b>
AHB (Automatic High Beam) .....	<b>195</b>
Fog light switch .....	<b>198</b>
Windshield wipers and washer .....	<b>199</b>
Rear window wiper and washer .....	<b>201</b>

**4-4. Refueling**

Opening the fuel tank cap.	<b>203</b>
----------------------------	------------

**4-5. Using the driving support systems**

Toyota Safety Sense .....	<b>205</b>
PCS (Pre-Collision System) .....	<b>210</b>
LTA (Lane Tracing Assist) .....	<b>220</b>
RSA (Road Sign Assist) ...	<b>231</b>

Dynamic radar cruise control with full-speed range .....	<b>234</b>
Cruise control.....	<b>246</b>
BSM (Blind Spot Monitor) .....	<b>249</b>
Toyota parking assist-sensor .....	<b>253</b>
RCTA (Rear Cross Traffic Alert) function .....	<b>263</b>
PKSB (Parking Support Brake) .....	<b>268</b>
Parking Support Brake function (static objects).....	<b>273</b>
Parking Support Brake function (rear-crossing vehicles) .....	<b>276</b>
Driving mode select switch .....	<b>278</b>
Trail Mode (AWD vehicles) .....	<b>280</b>
Driving assist systems .....	<b>281</b>

**4-6. Driving tips**

Hybrid Electric Vehicle driving tips .....	<b>288</b>
Winter driving tips .....	<b>290</b>
Utility vehicle precautions .....	<b>293</b>

## Driving the vehicle

The following procedures should be observed to ensure safe driving:

### Driving procedure

#### ■ Starting the hybrid system

→P.177

#### ■ Driving

- 1 With the brake pedal depressed, shift the shift lever to D.  
(→P.183)
- 2 Release the parking brake.  
(→P.187)

If the parking brake is in automatic mode, the parking brake will be released automatically. (→P.189)

- 3 Gradually release the brake pedal and gently depress the accelerator pedal to accelerate the vehicle.

#### ■ Stopping

- 1 With the shift lever in D, depress the brake pedal.
- 2 If necessary, set the parking brake. (→P.187)

If the vehicle is to be stopped for an extended period of time, shift the shift lever to P. (→P.183)

#### ■ Parking the vehicle

- 1 With the shift lever in D, depress the brake pedal.
- 2 Set the parking brake. (→P.187)

Make sure the parking brake indicator light is on.

- 3 Shift the shift lever to P  
(→P.183).

Do not press the shift release button after shifting the shift position to P.

- 4 Turn the power switch to OFF to stop the hybrid system.
- 5 Lock the door, making sure that you have the key on your person.

If parking on a hill, block the wheels as needed.

#### ■ Starting off on a steep uphill

- 1 With the brake pedal depressed, shift the shift lever to D.  
(→P.183)
- 2 Pull the parking brake switch to set the parking brake manually.  
(→P.187)
- 3 Release the brake pedal and gently depress the accelerator pedal to accelerate the vehicle.

Parking brake automatic release function (→P.189)

#### ■ When starting off on a uphill

The hill-start assist control will activate. (→P.282)

#### ■ For fuel-efficient driving

Keep in mind that Hybrid Electric Vehicles are similar to conventional vehicles, and it is necessary to refrain from activities such as sudden acceleration. (→P.288)

#### ■ Driving in the rain

- Drive carefully when it is raining, because visibility will be reduced, the windows may become fogged-up, and the road could be slippery.
- Drive carefully when it starts to rain, as the road surface could be especially slippery.

- Refrain from high speeds when driving on an expressway in the rain, because there may be a layer of water between the tires and the road surface, preventing the steering and brakes from operating properly.

#### ■ ECO Accelerator Guidance (→P.90)

It is easier to drive in an Eco-friendly manner by driving while referring to the ECO Accelerator Guidance display. Also, by using the ECO Accelerator Guidance it is easier to increase the “Eco Score” evaluation.

- When starting off: While staying within the ECO Accelerator Guidance range, gradually depress the accelerator pedal and accelerate to the desired speed. If excessive acceleration is avoided, the “Start” score will increase.
- When driving: After accelerating to the desired speed, release the accelerator pedal and drive at a stable speed within the ECO Accelerator Guidance range. By keeping the vehicle within the ECO Accelerator Guidance range, the “Cruise” score will increase.
- When stopping: When stopping the vehicle, early releasing the accelerator pedal will cause the “Stop” score to increase.

#### ■ Restraining the hybrid system output (Brake Override System)

- When the accelerator and brake pedals are depressed at the same time, the hybrid system output may be restrained.
- A warning message is displayed on the multi-information display while the system is operating.

#### ■ Breaking in your new Toyota

To extend the life of the vehicle, observing the following precautions is recommended:

- For the first 300 km (200 miles): Avoid sudden stops.
- For the first 800 km (500 miles): Do not tow a trailer.

- For the first 1000 km (600 miles):
  - Do not drive at extremely high speeds.
  - Avoid sudden acceleration.
  - Do not drive continuously in low gears.
  - Do not drive at a constant speed for extended periods.

#### ■ Operating your vehicle in a foreign country

Comply with the relevant vehicle registration laws and confirm the availability of the correct fuel. (→P.421)



#### WARNING

Observe the following precautions. Failure to do so may result in death or serious injury.

#### ■ When starting the vehicle

Always keep your foot on the brake pedal while stopped with the “READY” indicator is illuminated. This prevents the vehicle from creeping.

#### ■ When driving the vehicle

- Do not drive if you are unfamiliar with the location of the brake and accelerator pedals to avoid depressing the wrong pedal.
- Accidentally depressing the accelerator pedal instead of the brake pedal will result in sudden acceleration that may lead to an accident.
- When backing up, you may twist your body around, leading to a difficulty in operating the pedals. Make sure to operate the pedals properly.
- Make sure to keep a correct driving posture even when moving the vehicle only slightly. This allows you to depress the brake and accelerator pedals properly.
- Depress the brake pedal using your right foot. Depressing the brake pedal using your left foot may delay response in an emergency, resulting in an accident.

**WARNING**

- The driver should pay extra attention to pedestrians when the vehicle is powered only by the electric motor (traction motor). As there is no engine noise, the pedestrians may misjudge the vehicle's movement.
- Do not drive the vehicle over or stop the vehicle near flammable materials such as leaves, paper or rags. The exhaust system and exhaust gases can be extremely hot. These hot parts may cause a fire if there is any flammable material nearby.
- During normal driving, do not turn off the hybrid system. Turning the hybrid system off while driving will not cause loss of steering or braking control, however, power assist to the steering will be lost. This will make it more difficult to steer smoothly, so you should pull over and stop the vehicle as soon as it is safe to do so. In the event of an emergency, such as if it becomes impossible to stop the vehicle in the normal way: →P.376
- Use engine braking (downshift) to maintain a safe speed when driving down a steep hill. Using the brakes continuously may cause the brakes to overheat and lose effectiveness. (→P.183)
- Do not adjust the position of the steering wheel, the seat, or the inside or outside rear view mirrors while driving. Doing so may result in a loss of vehicle control.
- Always check that all passengers' arms, head or other parts of their body are not outside the vehicle.

**■ When driving on slippery road surfaces**

- Sudden braking, acceleration and steering may cause tire slippage and reduce your ability to control the vehicle.
- Sudden acceleration, engine braking due to shifting, or changes in engine speed could cause the vehicle to skid.
- After driving through a puddle, lightly depress the brake pedal to make sure that the brakes are functioning properly. Wet brake pads may prevent the brakes from functioning properly. If the brakes on only one side are wet and not functioning properly, steering control may be affected.

**■ When shifting the shift lever**

- Do not let the vehicle roll backward while a forward driving position is selected, or roll forward while the shift lever is in R. Doing so may result in an accident or damage to the vehicle.
- Do not shift the shift lever to P while the vehicle is moving. Doing so can damage the transmission and may result in a loss of vehicle control.
- Do not shift the shift lever to R while the vehicle is moving forward. Doing so can damage the transmission and may result in a loss of vehicle control.
- Do not shift the shift lever to a driving position while the vehicle is moving backward. Doing so can damage the transmission and may result in a loss of vehicle control.

**WARNING**

- Moving the shift lever to N while the vehicle is moving will disengage the hybrid system. Engine braking is not available with the hybrid system disengaged.
- Be careful not to shift the shift lever with the accelerator pedal depressed. Shifting the shift lever to a gear other than P or N may lead to unexpected rapid acceleration of the vehicle that may cause an accident and result in death or serious injury. Doing so can damage the transmission and may result in a loss of vehicle control.

■ **If you hear a squealing or scraping noise (brake pad wear indicators)**

Have the brake pads checked and replaced by your Toyota dealer as soon as possible. Rotor damage may result if the pads are not replaced when needed. It is dangerous to drive the vehicle when the wear limits of the brake pads and/or those of the brake discs are exceeded.

■ **When the vehicle is stopped**

- Do not depress the accelerator pedal unnecessarily. If the vehicle is in any gear other than P or N, the vehicle may accelerate suddenly and unexpectedly, causing an accident.
- In order to prevent accidents due to the vehicle rolling away, always keep depressing the brake pedal while stopped with the “READY” indicator is illuminated, and apply the parking brake as necessary.

- If the vehicle is stopped on an incline, in order to prevent accidents caused by the vehicle rolling forward or backward, always depress the brake pedal and securely apply the parking brake as needed.

- Avoid revving or racing the engine. Running the engine at high speed while the vehicle is stopped may cause the exhaust system to over-heat, which could result in a fire if combustible material is nearby.

■ **When the vehicle is parked**

- Do not leave glasses, cigarette lighters, spray cans, or soft drink cans in the vehicle when it is in the sun. Doing so may result in the following:
  - Gas may leak from a cigarette lighter or spray can, and may lead to a fire.
  - The temperature inside the vehicle may cause the plastic lenses and plastic material of glasses to deform or crack.
  - Soft drink cans may fracture, causing the contents to spray over the interior of the vehicle, and may also cause a short circuit in the vehicle's electrical components.
- Do not leave cigarette lighters in the vehicle. If a cigarette lighter is in a place such as the glove box or on the floor, it may be lit accidentally when luggage is loaded or the seat is adjusted, causing a fire.
- Do not attach adhesive discs to the windshield or windows. Do not place containers such as air fresheners on the instrument panel or dashboard. Adhesive discs or containers may act as lenses, causing a fire in the vehicle.

**WARNING**

- Do not leave a door or window open if the curved glass is coated with a metallized film such as a silver-colored one. Reflected sunlight may cause the glass to act as a lens, causing a fire.
- Always apply the parking brake, shift the shift lever to P, stop the hybrid system and lock the vehicle. Do not leave the vehicle unattended while the “READY” indicator is illuminated.  
If the vehicle is parked with the shift lever in P but the parking brake is not set, the vehicle may start to move, possibly leading to an accident.
- Do not touch the exhaust pipes while the “READY” indicator is illuminated or immediately after turning the hybrid system off. Doing so may cause burns.

**■ When taking a nap in the vehicle**

Always turn the hybrid system off. Otherwise, if you accidentally move the shift lever or depress the accelerator pedal, this could cause an accident or fire due to hybrid system overheating. Additionally, if the vehicle is parked in a poorly ventilated area, exhaust gases may collect and enter the vehicle, leading to death or a serious health hazard.

**■ When braking**

- When the brakes are wet, drive more cautiously.  
Braking distance increases when the brakes are wet, and this may cause one side of the vehicle to brake differently than the other side. Also, the parking brake may not securely hold the vehicle.

- If the electronically controlled brake system does not operate, do not follow other vehicles closely and avoid hills or sharp turns that require braking.

In this case, braking is still possible, but the brake pedal should be depressed more firmly than usual. Also, the braking distance will increase. Have your brakes fixed immediately.

- The brake system consists of 2 or more individual hydraulic systems; if one of the systems fails, the other will still operate. In this case, the brake pedal should be depressed more firmly than usual and the braking distance will increase. Have your brakes fixed immediately.

**■ If the vehicle becomes stuck (AWD models)**

Do not spin the wheels excessively when any of the tires is up in the air, or the vehicle is stuck in sand, mud, etc. This may damage the driveline components or propel the vehicle forward or backward, causing an accident.

**NOTICE****■ When driving the vehicle**

- Do not depress the accelerator and brake pedals at the same time during driving, as this may restrain the hybrid system output.
- Do not use the accelerator pedal or depress the accelerator and brake pedals at the same time to hold the vehicle on a hill.

**■ Avoiding damage to vehicle parts**

- Do not turn the steering wheel fully in either direction and hold it there for an extended period of time. Doing so may damage the power steering motor.



**NOTICE**

- When driving over bumps in the road, drive as slowly as possible to avoid damaging the wheels, underside of the vehicle, etc.

**■ If you get a flat tire while driving**

A flat or damaged tire may cause the following situations.

- It may be difficult to control your vehicle.
- The vehicle will make abnormal sounds or vibrations.
- The vehicle will lean abnormally.

Hold the steering wheel firmly and gradually depress the brake pedal to slow down the vehicle. Information on what to do in case of a flat tire (→P.396)

**■ When encountering flooded roads**

Do not drive on a road that has flooded after heavy rain, etc. Doing so may cause the following serious damage to the vehicle:

- Engine stalling
- Short in electrical components
- Engine damage caused by water immersion

In the event that you drive on a flooded road and the vehicle is flooded, be sure to have your Toyota dealer check the following:

- Brake function
- Changes in quantity and quality of oil and fluid used for the engine, hybrid transaxle (front and rear [AWD models]), etc.
- Lubricant condition for the bearings and suspension joints (where possible), and the function of all joints, bearings, etc.

**■ When parking the vehicle**

Always set the parking brake, and shift the shift lever to P. Failure to do so may cause the vehicle to move or the vehicle may accelerate suddenly if the accelerator pedal is accidentally depressed.

**Sudden start restraint control (Drive-Start Control [DSC])**

When the following unusual operation is performed with the accelerator pedal depressed, the hybrid system output may be restrained.

- When the shift lever is shifted to R\*.
- When the shift lever is shifted from P or R to forward drive shift position such as D\*.

When the system operates, a message appears on the multi-information display. Read the message and follow the instruction.

\*: Depending on the situation, the shift position may not be changed.

**■ Drive-Start Control (DSC)**

- When the TRC is turned off (→P.283), sudden start restraint control also does not operate. If your vehicle have trouble escaping from the mud or fresh snow due to sudden start restraint control operation, deactivate TRC (→P.283) so that the vehicle may become able to escape from the mud or fresh snow.

Also, sudden start restraint control will not operate in the following condition:

- When Trail Mode is turned on (AWD vehicles)

## Cargo and luggage

**Take notice of the following information about storage precautions, cargo capacity and load.**



### WARNING

#### ■ Things that must not be carried in the luggage compartment

The following things may cause a fire if loaded in the luggage compartment:

- Receptacles containing gasoline
- Aerosol cans

#### ■ Storage precautions

Observe the following precautions. Failure to do so may prevent the pedals from being depressed properly, may block the driver's vision, or may result in items hitting the driver or passengers, possibly causing an accident.

- Stow cargo and luggage in the luggage compartment whenever possible.
- Do not stack anything in the luggage compartment higher than the seatbacks.
- When you fold down the rear seats, long items should not be placed directly behind the front seats.
- Never allow anyone to ride in the luggage compartment. It is not designed for passengers. They should ride in their seats with their seat belts properly fastened. Otherwise, they are much more likely to suffer death or serious bodily injury, in the event of sudden braking, sudden swerving or an accident.

- Do not place cargo or luggage in or on the following locations.

- At the feet of the driver
- On the front passenger or rear seats (when stacking items)
- On the luggage cover
- On the instrument panel
- On the dashboard

- Secure all items in the occupant compartment.

#### ■ Load and distribution

- Do not overload your vehicle.

- Do not apply loads unevenly.

Improper loading may cause deterioration of steering or braking control which may cause death or serious injury.

#### ■ When loading cargo on the roof luggage carrier (if equipped)

Observe the following precautions:

- Place the cargo so that its weight is distributed evenly between the front and rear axles.
- If loading long or wide cargo, never exceed the vehicle overall length or width. (→P.420)
- Before driving, make sure the cargo is securely fastened on the roof luggage carrier.
- Loading cargo on the roof luggage carrier will make the center of gravity of the vehicle higher. Avoid high speeds, sudden starts, sharp turns, sudden braking or abrupt maneuvers, otherwise it may result in loss of control or vehicle rollover due to failure to operate this vehicle correctly and result in death or serious injury.
- If driving for a long distance, on rough roads, or at high speeds, stop the vehicle now and then during the trip to make sure the cargo remains in its place.

**WARNING**

- Do not exceed 80 kg (176.4 lb.) cargo weight on the roof luggage carrier.

**NOTICE**

- **When loading cargo on the roof luggage carrier (if equipped)**

Be careful not to scratch the surface of the moon roof (if equipped).

**Trailer towing (except Australia and New Zealand)**

**Toyota does not recommend towing a trailer with your vehicle. Toyota also does not recommend the installation of a tow hitch or the use of a tow hitch carrier for a wheelchair, scooter, bicycle, etc. Your vehicle is not designed for trailer towing or for the use of tow hitch mounted carriers.**

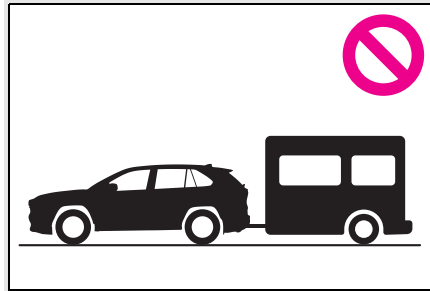

## Trailer towing (for Australia and New Zealand)

**Your vehicle is designed primarily as a passenger carrying vehicle. Towing a trailer will have an adverse effect on handling, performance, braking, durability, and fuel consumption. For your safety and the safety of others, do not overload the vehicle or trailer. Toyota warranties do not apply to damage or malfunction caused by towing a trailer for commercial purposes.**

For towing purposes, when the total trailer weight is greater than the vehicle weight, we recommended use of a sway control device.

### ■ Before towing

Check that the following conditions are met:

- The vehicle's tires are properly inflated. (→P.426)
- Trailer tires are inflated according to the trailer manufacturer's recommendation.
- All trailer lights work.
- All lights work each time you connect them.
- The trailer ball is set up at the proper height for the coupler on the trailer.
- The trailer is level when it is hitched. Do not drive if the trailer is not level, and check for improper tongue weight, overloading, worn suspension, or other possible causes.
- The trailer cargo is securely loaded.

- The rear view mirrors conform to all applicable federal, state/provincial or local regulations. If they do not, install rear view mirrors appropriate for towing purposes.

### ■ When towing a trailer

Disable the following systems, as the systems may not operate properly.

- LTA (Lane Tracing Assist) (if equipped) (→P.220)
- Dynamic radar cruise control with full-speed range (if equipped) (→P.234)
- Cruise control (if equipped) (→P.246)
- PKSB (Parking Support Brake) (if equipped) (→P.268)
- BSM (Blind Spot Monitor) (if equipped) (→P.249)
- Toyota parking assist-sensor (→P.253)
- RCTA (Rear Cross Traffic Alert) function (if equipped) (→P.249)



### WARNING

#### ■ To avoid accident or injury

- The total trailer weight (trailer weight plus the weight of cargo) must not exceed the following:
  - 2WD models: 480 kg (1058 lb.)
  - AWD models: 1500 kg (3307 lb.)
- The gross combined weight (sum of your vehicle weight plus its load and the total trailer weight) must not exceed the following:
  - 2WD models: 2665 kg (5875 lb.)
  - AWD models: 3730 kg (8223 lb.)
- Do not exceed the trailer hitch assembly weight, gross vehicle weight, gross axle weight and trailer tongue load capacities.

**WARNING**

- Never load more weight in the back than in the front of the trailer. About 60% of the load should be in the front half of the trailer, and the remaining 40% in the rear.
- Vehicles with compact spare tire: Do not tow a trailer when the compact spare tire is installed on your vehicle.
- **When towing a trailer**
- AWD models: If the total trailer weight exceeds 750 kg (1653 lb.), trailer brakes are required.
- Never tap into your vehicle's hydraulic system, as this will lower the vehicle's braking effectiveness.
- Never tow a trailer without using a safety chain securely attached to both the trailer and the vehicle. If damage occurs to the coupling unit or hitch ball, there is a risk of the trailer wandering into another lane.
- **When the gross vehicle mass or maximum permissible axle capacity is exceeded**

Failing to observe this precaution may lead to an accident causing death or serious injury.

- Add an additional 20.0 kPa (0.2 kgf/cm<sup>2</sup> or bar, 3 psi) to the recommended tire inflation pressure value. (→P.426)
- Do not exceed the established speed limit for towing a trailer in built-up areas or 100 km/h (62 mph), whichever is lower.

**NOTICE**■ **Brakes**

Toyota recommends trailers with brakes that conform to all applicable federal and state/provincial regulations.

**Weight limits**

Confirm that the total trailer weight, gross vehicle weight, gross axle weight and trailer tongue load are all within the limits.

**Gross vehicle weight**

The gross vehicle weight must not exceed the following:

- 2WD models: 2185 kg (4817 lb.)
- AWD models: 2230 kg (4916 lb.)

The gross vehicle weight is the sum weight of the unloaded vehicle, driver, passengers, luggage, hitch and trailer tongue load. Also included is the weight of any special equipment installed on your vehicle.

**Gross axle weight**

The load on either the front or rear axle resulting from distribution of the gross vehicle weight on both axles must not exceed the following:

- 2WD models
  - Front: 1150 kg (2535 lb.)
  - Rear: 1150 kg (2535 lb.)
- AWD models

- Front: 1220 kg (2690 lb.)
- Rear: 1220 kg (2690 lb.)

### Trailer tongue load

The trailer cargo load should be distributed so that the tongue load is 9 to 11% of the total trailer weight, not exceed the following:

- 2WD models: 50 kg (110 lb.)
- AWD models: 150 kg (331 lb.)

(Tongue load/Total trailer weight  $\times$  100 = 9 to 11%)

The total trailer weight and tongue load can be measured with platform scales found at a highway weighing stations, building supply companies, trucking companies, junk yards, etc.

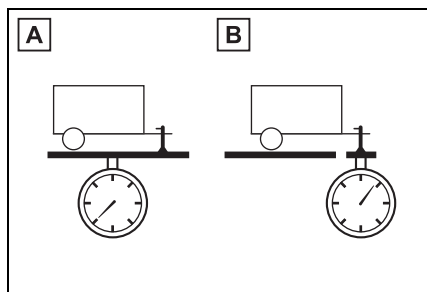

**A** Total trailer weight

**B** Tongue load

### Towing a trailer

Contact your Toyota dealer for further information about additional requirements such as a towing kits etc.

### Hitch

Trailer hitch assemblies have different weight capacities established by the hitch manufacturer. Even though the vehicle may be rated for towing a higher weight, the operator must never exceed the maximum weight rating specified for the trailer hitch.

For vehicles where the towing device blocks any of the lights or license plate, the following shall be observed:

- Do not use towing devices that cannot be easily removed or repositioned.
- Towing devices must be removed or repositioned when not in use.

### WARNING

#### ■ Hitches

- Use only a hitch that conforms to the total trailer weight requirement.
- Follow the directions supplied by the hitch manufacturer.
- Depending on the type of trailer coupler you use, the trailer ball may need to be coated with grease. If so, apply grease to the trailer ball in accordance with the instructions of the manufacturer of the trailer coupler.
- Remove the hitch ball whenever you are not towing a trailer. Remove the trailer hitch if you do not need it. After removing the hitch, seal any mounting holes in the vehicle body to prevent entry of any substances into the vehicle.

**NOTICE**

**When installing a trailer hitch**

- Use only the position recommended by your Toyota dealer. Do not install the trailer hitch on the bumper; this may cause body damage.
- Do not use axle-mounted hitches, as they can cause damage to the axle housing, wheel bearings, wheels or tires.

### Selecting a trailer ball

Use the correct trailer ball for your application.

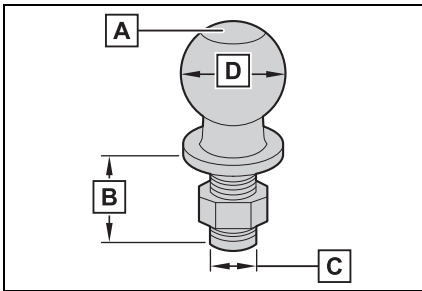

**A** Trailer ball load rating

Matches or exceeds the gross trailer weight rating of the trailer.

**B** Shank length

Protrudes beyond the bottom of the lock washer and nut at least 2 threads.

**C** Shank diameter

Matches the ball mount hole diameter size.

**D** Ball diameter

Matches the size of the trailer coupler. Most couplers are stamped with the required trailer ball size.

### Connecting trailer lights

Please consult your dealer when installing trailer lights, as incorrect installation may cause damage to the vehicle's lights. Please take care to comply with your state's laws when installing trailer lights.

**NOTICE**

**Do not directly splice trailer lights**

Directly splicing trailer lights may damage your vehicle's electrical system and cause a malfunction.

### Trailer towing tips

Your vehicle will handle differently when towing a trailer. In order to avoid accident, death or serious injury, keep the following in mind when towing:

- Before starting out, check the trailer lights and the vehicle-trailer connections. Recheck after driving a short distance.
- Practice turning, stopping and reversing with the trailer attached in an area away from traffic until you become accustomed to the feel of the vehicle.
- Reversing with a trailer attached is difficult and requires practice. Grip the bottom of the steering wheel and move your hand to the left to move the trailer to the left. Move your hand to the right to move the trailer to right. (This is generally opposite to reversing

without a trailer attached.) Avoid sharp or prolonged turning. Have someone guide you when reversing to reduce the risk of an accident.

- As stopping distance is increased when towing a trailer, vehicle-to-vehicle distance should be increased. For each 10 km/h (6 mph) of speed, allow at least one vehicle and trailer length.
  - Avoid sudden braking as you may skid, resulting in jackknifing and loss of control. This is especially true on wet or slippery surfaces.
  - Avoid jerky starts or sudden acceleration.
  - Avoid jerky steering and sharp turns, and slow down before making turns.
  - Note that when making a turn, the trailer wheels will be closer than the vehicle wheels to the inside of the turn. Compensate by making a larger than normal turning radius.
  - Crosswinds and rough roads will adversely affect handling of your vehicle and trailer, causing sway. Periodically check the rear to prepare for being passed by large trucks or buses, which may cause your vehicle and trailer to sway. If swaying occurs, firmly grip the steering wheel, reduce speed immediately but gradually, and steer straight ahead. Never increase speed. If you make no extreme correction with the steering or brakes, your vehicle and trailer will stabilize.
- Take care when passing other vehicles. Passing requires considerable distance. After passing a vehicle, do not forget the length of your trailer, and be sure you have plenty of room before changing lanes.
  - To maintain engine braking efficiency and charging system performance, when using engine braking, do not use the transmission in D.
  - Due to the added load of the trailer, your vehicle's hybrid system may overheat on hot days (at temperatures over 30°C [85°F]) when driving up a long or steep grade. If the engine coolant temperature gauge indicates overheating, immediately turn off the air conditioning (if in use), pull your vehicle off the road and stop in a safe spot. (→P.413)
  - Always place wheel blocks under both the vehicle and the trailer wheels when parking. Apply the parking brake firmly, and put the transmission in P. Avoid parking on a slope, but if unavoidable, do so only after performing the following:
    - 1 Apply the brakes and keep them applied.



- 2 Have someone place wheel blocks under both the vehicle and trailer wheels.
  - 3 When the wheel blocks are in place, release the brakes slowly until the blocks absorb the load.
  - 4 Apply the parking brake firmly.
  - 5 Shift into the P and turn off the hybrid system.
- When restarting after parking on a slope:
    - 1 With the transmission in the P position, start the hybrid system. Be sure to keep the brake pedal depressed.
    - 2 Shift into forward gear or R gear position (if reversing).
    - 3 If the parking brake is in manual mode, release the parking brake. (→P.187)
    - 4 Release the brake pedal, and slowly pull or back away from the wheel blocks. Stop and apply the brakes.
    - 5 Have someone retrieve the blocks.

#### ■ Break-in schedule

Toyota recommends that you do not use a new vehicle or a vehicle with any new power train components (engine, transmission, differential, wheel bearings, etc.) to tow a trailer for the first 800 km (500 miles) of driving.

#### ■ Maintenance

- If you tow a trailer, your vehicle will require more frequent maintenance due to the additional load. (See “Warranty and Service Booklet”.)

- Retighten the fixing bolts of the towing ball and bracket after approximately 1000 km (600 miles) of trailer towing.

#### ■ If trailer sway occurs

One or more factors (crosswinds, passing vehicles, rough roads, etc.) can adversely affect handling of your vehicle and trailer, causing instability.

- If trailer swaying occurs:

- Firmly grip the steering wheel. Steer straight ahead.  
Do not try to control trailer swaying by turning the steering wheel.
- Begin releasing the accelerator pedal immediately but very gradually to reduce speed.  
Do not increase speed. Do not apply vehicle brakes.

If you make no extreme correction with the steering or brakes, your vehicle and trailer should stabilize (if enabled, Trailer Sway Control can also help to stabilize the vehicle and trailer.).

- After the trailer swaying has stopped:
  - Stop in a safe place. Get all occupants out of the vehicle.
  - Check the tires of the vehicle and the trailer.
  - Check the load in the trailer.  
Make sure the load has not shifted.  
Make sure the tongue weight is appropriate, if possible.
  - Check the load in the vehicle.  
Make sure the vehicle is not overloaded after occupants get in.

If you cannot find any problems, the speed at which trailer swaying occurred is beyond the limit of your particular vehicle-trailer combination. Drive at a lower speed to prevent instability. Remember that swaying of the towing vehicle-trailer increases as speed increases.

**WARNING****■ To avoid an accident**

- Observe the legal maximum speeds for trailer towing.
- Slow down and downshift before descending steep or long downhill grades. Do not make sudden downshifts while descending steep or long downhill grades.
- Avoid holding the brake pedal down too long or applying the brakes too frequently. This could cause the brakes to overheat and result in reduced braking efficiency.
- Do not use cruise control or dynamic radar cruise control with full-speed range (if equipped) when trailer towing.

## Power (ignition) switch

Performing the following operations when carrying the electronic key on your person starts the hybrid system or changes power switch modes.

### Starting the hybrid system

- 1 Pull the parking brake switch to check that the parking brake is set. (→P.187)

The parking brake indicator will come on.

- 2 Check that the shift lever is set in P.
- 3 Firmly depress the brake pedal.

 and a message will be displayed on the multi-information display. If it is not displayed, the hybrid system cannot be started.

- 4 Press the power switch shortly and firmly.

When operating the power switch, one short, firm press is enough. It is not necessary to press and hold the switch.

If the “READY” indicator turns on, the hybrid system will operate normally.

Continue depressing the brake pedal until the “READY” indicator is illuminated.

The hybrid system can be started from

any power switch mode.

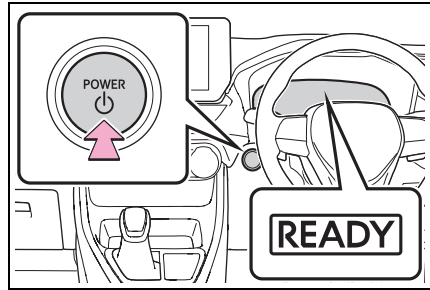

- 5 Check that the “READY” indicator is illuminated.

The vehicle will not move when the “READY” indicator is off.

#### ■ If the hybrid system does not start

- The immobilizer system may not have been deactivated. (→P.68)  
Contact your Toyota dealer.
- If a message related to start-up is shown on the multi-information display, read the message and follow the instructions.
- If the door is unlocked with the mechanical key, the hybrid system cannot be started using the smart entry & start system. Refer to P.407 to start the hybrid system. However, if the electronic key is carried inside the vehicle and the doors are locked (→P.118), the hybrid system can be started.

#### ■ When the ambient temperature is low, such as during winter driving conditions

- When starting the hybrid system, the flashing time of the “READY” indicator may be long. Leave the vehicle as it is until the “READY” indicator is steady on, as steady means the vehicle is able to move.

#### ■ Sounds and vibrations specific to a Hybrid Electric Vehicle

→P.62

### ■ If the 12-volt battery is discharged

The hybrid system cannot be started using the smart entry & start system. Refer to P.408 to restart the hybrid system.

### ■ Electronic key battery depletion

→P.112

### ■ Conditions affecting operation

→P.131

### ■ Note for the entry function

→P.131

### ■ If there is a malfunction in the smart entry & start system

If “Smart Entry & Start System Malfunction” is displayed on the multi-information display, the system may be malfunctioning. Have the vehicle inspected by your Toyota dealer immediately.

### ■ If the “READY” indicator does not come on

In the event that the “READY” indicator does not come on even after performing the proper procedures for starting the vehicle, contact your Toyota dealer immediately.

### ■ If the hybrid system is malfunctioning

→P.66

### ■ Electronic key battery

→P.363

### ■ Operation of the power switch

● If the switch is not pressed shortly and firmly, the power switch mode may not change or the hybrid system may not start.

● If attempting to restart the hybrid system immediately after turning the power switch to OFF, the hybrid system may not start in some cases. After turning the power switch to OFF, please wait a few seconds before restarting the hybrid system.

### ■ Customization

If the smart entry & start system has

been deactivated in a customized setting, refer to P.407.



### WARNING

#### ■ When starting the hybrid system

Always start the hybrid system while sitting in the driver's seat. Do not depress the accelerator pedal while starting the hybrid system under any circumstances.

Doing so may cause an accident resulting in death or serious injury.



### NOTICE

#### ■ When starting the hybrid system

If the hybrid system becomes difficult to start, have your vehicle checked by your Toyota dealer immediately.

#### ■ Symptoms indicating a malfunction with the power switch

If the power switch seems to be operating somewhat differently than usual, such as the switch sticking slightly, there may be a malfunction. Contact your Toyota dealer immediately.

## Stopping the hybrid system

- 1 Stop the vehicle completely.
- 2 If the parking brake is in manual mode, set the parking brake. (→P.187)

Check the parking brake indicator is illuminated.

- 3 Shift the shift lever to P.
- 4 Press the power switch shortly and firmly.

The hybrid system will stop, and the meter display will be extinguished.

- 5 Release the brake pedal and check that “ACCESSORY” or

“IGNITION ON” is not shown on the multi-information display.

### WARNING

#### ■ Stopping the hybrid system in an emergency

- If you want to stop the hybrid system in an emergency while driving the vehicle, press and hold the power switch for more than 2 seconds, or press it briefly 3 times or more in succession. (→P.376) However, do not touch the power switch while driving except in an emergency. Turning the hybrid system off while driving will not cause loss of steering or braking control, however, power assist to the steering will be lost. This will make it more difficult to steer smoothly, so you should pull over and stop the vehicle as soon as it is safe to do so.
- If the power switch is operated while the vehicle is running, a warning message will be shown on the multi-information display and a buzzer sounds.
- When restarting the hybrid system after an emergency shutdown, shift the shift lever to N and press the power switch shortly and firmly.

### Changing power switch modes

Modes can be changed by pressing the power switch with the brake pedal released. (The mode changes each time the switch is pressed.)

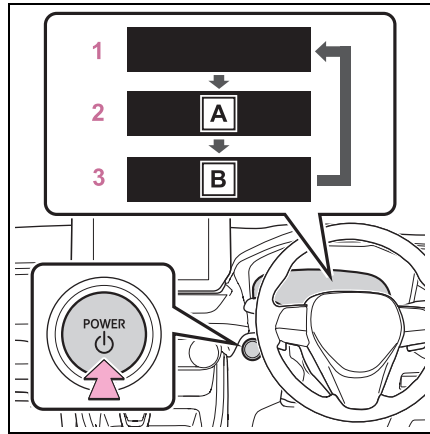

**A** “ACCESSORY”

**B** “IGNITION ON”

#### 1 OFF\*

The emergency flashers can be used.

#### 2 ACC

Some electrical components such as the audio system can be used.

“ACCESSORY” will be displayed on the multi-information display.

#### 3 ON

All electrical components can be used.

“IGNITION ON” will be displayed on the multi-information display.

\*: If the shift lever is in a position other than P when turning off the hybrid system, the power switch will be turned to ACC, not to OFF.

#### ■ Auto power off function

If the vehicle is left in ACC for more than 20 minutes or ON (the hybrid system is not operating) for more than an hour with the shift lever in P, the power switch will automatically turn to OFF. However, this function cannot entirely prevent the 12-volt battery discharge. Do not leave the vehicle with the power switch in ACC or ON for long periods of time when the

hybrid system is not operating.



#### NOTICE

##### ■ To prevent 12-volt battery discharge

- Do not leave the power switch in ACC or ON for long periods of time without the hybrid system on.
- If “ACCESSORY” or “IGNITION ON” is displayed on the multi-information display, the power switch is not in OFF. Exit the vehicle after turning the power switch to OFF.

### When stopping the hybrid system with the shift lever in a position other than P

If the hybrid system is stopped with the shift lever in a position other than P, the power switch will not be turned to OFF but instead be turned to ACC. Perform the following procedure to turn the switch to OFF:

- 1 Check that the parking brake is set.
- 2 Shift the shift lever to P.
- 3 Check that “ACCESSORY” is displayed on the multi-information display and press the power switch shortly and firmly.
- 4 Check that “ACCESSORY” or “IGNITION ON” on the multi-information display is off.



#### NOTICE

##### ■ To prevent 12-volt battery discharge

Do not stop the hybrid system when the shift lever is in a position other than P. If the hybrid system is stopped in another shift lever position, the power switch will not be turned to OFF but instead be turned to ACC. If the vehicle is left in ACC, 12-volt battery discharge may occur.

## EV drive mode

In EV drive mode, electric power is supplied by the hybrid battery (traction battery), and only the electric motor (traction motor) is used to drive the vehicle.

This mode allows you to drive in residential areas early in the morning and late at night, or in indoor parking lots etc. without concern for noises and gas emissions.

## Operating instructions

Turns EV drive mode on/off

When EV drive mode is turned on, the EV drive mode indicator will come on. Pressing the switch when in EV drive mode will return the vehicle to normal driving (using the gasoline engine and electric motor [traction motor]).

### ▶ 2WD models

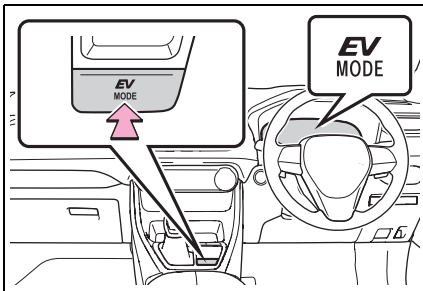

### ▶ AWD models

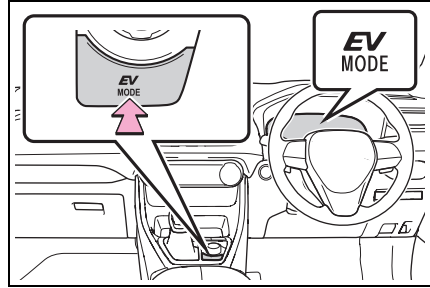

### ■ Situations in which EV drive mode cannot be turned on

It may not be possible to turn EV drive mode on in the following situations. If it cannot be turned on, a buzzer will sound and a message will be shown on the multi-information display.

- The temperature of the hybrid system is high.  
The vehicle has been left in the sun, driven on a hill, driven at high speeds, etc.
  - The temperature of the hybrid system is low.  
The vehicle has been left in temperatures lower than about 0°C (32°F) for a long period of time etc.
  - The gasoline engine is warming up.
  - The hybrid battery (traction battery) is low.  
The remaining battery level indicated in the Energy monitor display is low. (→P.109)
  - Vehicle speed is high.
  - The accelerator pedal is depressed firmly or the vehicle is on a hill etc.
  - The windshield defogger is in use.
- Use the EV drive mode when it becomes available.

### ■ Switching to EV drive mode when the gasoline engine is cold

If the hybrid system is started while the gasoline engine is cold, the gasoline engine will start automatically after a

short period of time in order to warm up.

In this case, you will become unable to switch to EV drive mode. After the hybrid system has started and the "READY" indicator has illuminated, press the EV drive mode switch before the gasoline engine starts to switch to EV drive mode.

#### ■ Automatic cancelation of EV drive mode

When driving in EV drive mode, the gasoline engine may automatically restart in the following situations. When EV drive mode is canceled, a buzzer will sound, the EV drive mode indicator will flash and go off and a message will be shown on the multi-information display.

- The hybrid battery (traction battery) becomes low.  
The remaining battery level indicated in the Energy monitor display is low. (→P.109)
- Vehicle speed is high.
- The accelerator pedal is depressed firmly or the vehicle is on a hill etc.

Drive the vehicle for a while before attempting to turn on the EV drive mode again.

#### ■ Possible driving distance when driving in EV drive mode

EV drive mode's possible driving distance ranges from a few hundred meters to approximately 1 km (0.6 mile). However, depending on vehicle conditions, there are situations when EV drive mode cannot be used.

(The distance that is possible depends on the hybrid battery [traction battery] level and driving conditions.)

#### ■ Fuel economy

The hybrid system is designed to achieve the best possible fuel economy during normal driving (using the gasoline engine and electric motor [traction motor]). Driving in EV drive mode more than necessary may lower fuel economy.



### WARNING

#### ■ Caution while driving

When driving in EV drive mode, pay special attention to the area around the vehicle. Because there is no engine noise, pedestrians, people riding bicycles or other people and vehicles in the area may not be aware of the vehicle starting off or approaching them, so take extra care while driving.



## Hybrid transmission

Select the shift position depending on your purpose and situation.

### Shift position purpose and functions

Shift position	Objective or function
P	Parking the vehicle/starting the hybrid system
R	Reversing
N	Neutral
D	Normal driving <sup>*1</sup>
S	S mode driving <sup>*2</sup>

<sup>\*1</sup>: To improve fuel efficiency and reduce noise, shift the shift lever to D for normal driving.

<sup>\*2</sup>: By selecting shift ranges using S mode, you can control accelerating force and engine braking force.

### ■ When driving with dynamic radar cruise control with full-speed range or cruise control activated (if equipped)

Even when performing the following actions with the intent of enabling engine braking, engine braking will not activate because dynamic radar cruise control with full-speed range or cruise control will not be canceled.

- While driving in S mode, downshifting to 5 or 4. (→P.185)
- When switching the driving mode to sport mode while driving in D position. (→P.278)

### ■ Restraining sudden start (Drive-Start Control)

(→P.167)



#### WARNING

#### ■ When driving on slippery road surfaces

Be careful of downshifting and sudden acceleration, as this could result in the vehicle skidding to the side or spinning.



#### NOTICE

#### ■ Hybrid battery (traction battery) charge

If the shift lever is in N, the hybrid battery (traction battery) will not be charging, even when the engine is running. Therefore, if the vehicle is left with the shift lever in N for a certain amount of time, the hybrid battery (traction battery) will discharge, and this may result in the vehicle not being able to start.

## Shifting the shift lever

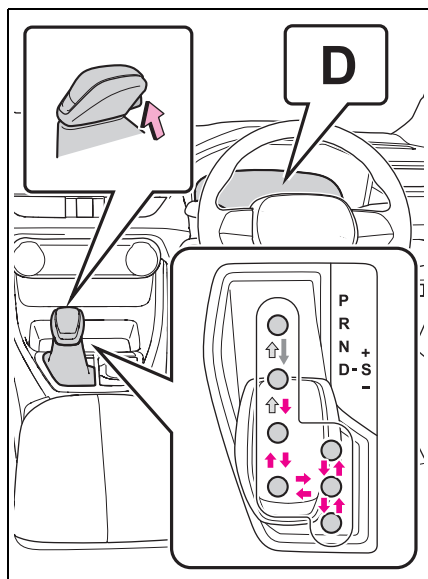

← While the power switch is

in ON and the brake pedal depressed\*, shift the shift lever while pushing the shift release button on the shift knob.

← Shift the shift lever while

pushing the shift release button on the shift knob.

← Shift the shift lever nor-

mally.

When shifting the shift lever between P and D, make sure that the vehicle is completely stopped and the brake pedal is depressed.

\*: For the vehicle to be able to be

shifted from P, the brake pedal must be depressed before the shift release button is pushed. If the shift release button is pushed first, the shift lock will not be released.

### ■ Shift lock system

The shift lock system is a system to prevent accidental operation of the shift lever in starting.

The shift lever can be shifted from P only when the power switch is in ON, the brake pedal is depressed and the shift release button is pushed.

### ■ If the shift lever cannot be shifted from P

First, check whether the brake pedal is being depressed.

If the shift lever cannot be shifted even though the brake pedal is depressed and the shift release button is pushed, there may be a problem with the shift lock system. Have the vehicle inspected by your Toyota dealer immediately.

The following steps may be used as an emergency measure to ensure that the shift lever can be shifted.

Releasing the shift lock:

- 1 Pull the parking brake switch to check that the parking brake is set. (→P.187)
- 2 Turn the power switch to OFF.
- 3 Depress the brake pedal.
- 4 Pry the cover up with a flathead screwdriver or equivalent tool. To prevent damage to the cover, cover the tip of the screwdriver with a rag.

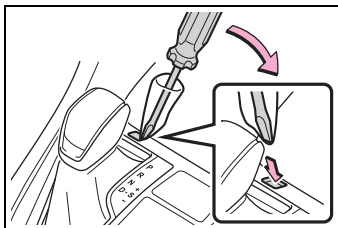

- 5 Press and hold the shift lock override button and then push the button on the shift knob. The shift lever can be shifted while both buttons are pressed.

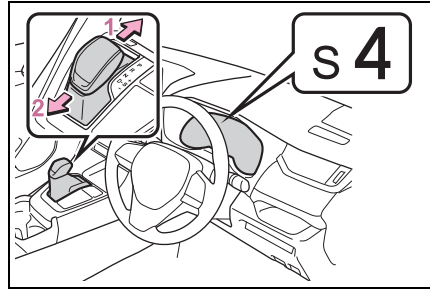
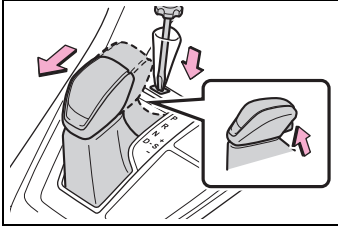

- 1 Upshifting  
2 Downshifting

### **⚠ WARNING**

#### **■ To prevent an accident when releasing the shift lock**

Before pressing the shift lock override button, make sure to set the parking brake and depress the brake pedal.

If the accelerator pedal is accidentally depressed instead of the brake pedal when the shift lock override button is pressed and the shift lever is shifted out of P, the vehicle may suddenly start, possibly leading to an accident resulting in death or serious injury.

The selected shift range, from S1 to S6, will be displayed on the multi-information display.

The initial shift range in S mode is set automatically to S3, S4 or S5 according to vehicle speed.

#### **■ S mode**

- You can choose from 6 levels of accelerating force and engine braking force.
- A lower shift range will provide greater accelerating force and engine braking force than a higher shift range and the engine revolutions will also increase.
- To prevent the engine from over-revving, upshifting may automatically occur when the shift range is 4 or lower.
- When the shift range is 4 or lower, holding the shift lever toward “+” sets the shift range to 6.

#### **■ Downshifting restriction warning buzzer**

To help ensure safety and driving performance, downshifting operation may sometimes be restricted. In some circumstances, downshifting may not be possible even when the shift lever is operated. (A buzzer will sound twice.)

## Selecting the driving mode

→P.278

## Changing shift ranges in S mode

When the shift lever is in the S position, the shift lever can be operated as follows:

- If the “S” indicator does not come on or the “D” indicator is displayed even after shifting the shift lever to S

This may indicate a malfunction in the transmission system. Have the vehicle inspected by your Toyota dealer immediately. (In this situation, the transmission will operate in the same manner as when the shift lever is in D.)

## Turn signal lever

### Operating instructions

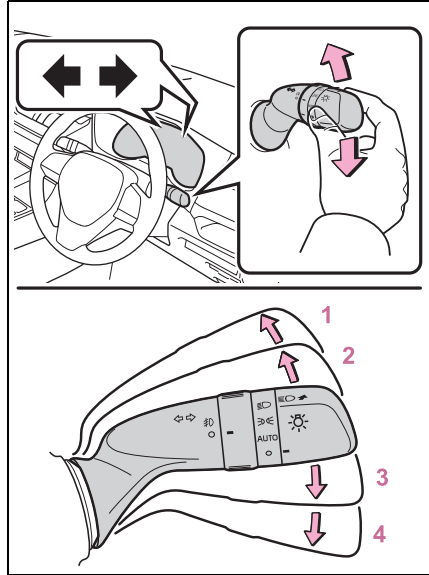

- 1 Left turn
- 2 Lane change to the left (move the lever partway and release it)  
The left hand signals will flash 3 times.
- 3 Lane change to the right (move the lever partway and release it)  
The right hand signals will flash 3 times.
- 4 Right turn

- Turn signals can be operated when The power switch is in ON.

- If the indicator flashes faster than usual

Check that a light bulb in the front or rear turn signal lights has not burned out.

- If the turn signals stop flashing before a lane change has been performed

Operate the lever again.

- To discontinue flashing of the turn signals during a lane change

Operate the lever in the opposite direction.

## Parking brake

The parking brake can be set or released automatically or manually.

In automatic mode, the parking brake can be set or released automatically according to shift lever operation. Also, even in automatic mode, the parking brake can be set or released manually.

## Operating instructions

- Using the manual mode

The parking brake can be set and released manually.

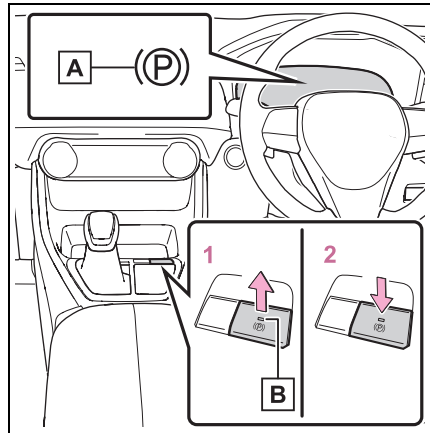

**A** Parking brake indicator light

**B** Parking brake switch indicator

- 1 Pull the switch to set the parking brake.

The parking brake indicator light and the parking brake switch indicator will turn on.

Pull and hold the parking brake switch if an emergency occurs and it is necessary to operate the parking brake while driving.

## 2 Press the switch to release the parking brake.

- Operate the parking brake switch while depressing the brake pedal.
- Using the parking brake automatic release function, the parking brake can be released by depressing the accelerator pedal. When using this function, slowly depress the accelerator pedal. (→P.189)

Make sure that the parking brake indicator light and the parking brake switch indicator turn off.

If the parking brake indicator light and the parking brake switch indicator flash, operate the switch again. (→P.390)

### ■ Turning the automatic mode on

While the vehicle is stopped, pull and hold the parking brake switch until a buzzer sounds and a message is shown on the multi-information display.



When the automatic mode is turned on, the parking brake operates as follows.

- When the shift lever is shifted from P, the parking brake will be released, and the parking brake indicator light and the parking brake switch indicator will turn off.
- When the shift lever is shifted to P, the parking brake will be set, and the parking brake indicator light and the parking brake switch indicator will turn on.

Operate the shift lever with the vehicle stopped and the brake pedal depressed.

The auto function may not operate if the shift lever is moved extremely quickly or the brake pedal is not firmly depressed.

In this situation, apply the parking brake manually. (→P.187)

### ■ Turning the automatic mode off

While the vehicle is stopped and depressing the brake pedal, press and hold the parking brake switch until a buzzer sounds and a message is shown on the multi-information display.

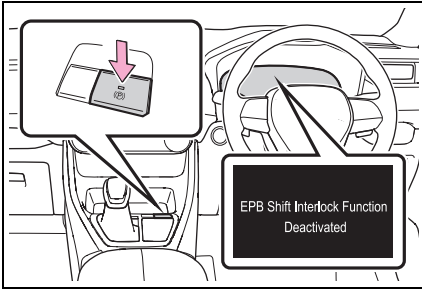

### ■ Parking brake operation

- When the power switch is not in ON, the parking brake cannot be released using the parking brake switch.
- When the power switch is not in ON, automatic mode (automatic brake setting and releasing) is not available.

### ■ Parking brake automatic release function

When all of the following conditions are met, the parking brake can be released by depressing the accelerator pedal.

- The driver's door is closed
- The driver is wearing the seat belt
- The shift lever is in a forward driving position or reverse driving position
- The malfunction indicator lamp or brake system warning light is not illuminated

When depressing the accelerator pedal, depress it slowly.

If the parking brake is not released when the accelerator pedal is depressed, release the parking brake manually.

When the shift lever is shifted from P, the parking brake will be released automatically.

### ■ Parking brake automatic lock function

The parking brake will be set automatically under the following conditions:

- The brake pedal is not depressed
- The driver's door is open

- The driver's seat belt is not fastened
- The shift lever is in a position other than P or N
- The malfunction indicator lamp and brake system warning light are not illuminated

### ■ If "Parking Brake Temporarily Unavailable" is displayed on the multi-information display

If the parking brake is operated repeatedly over a short period of time, the system may restrict operation to prevent overheating. If this happens, refrain from operating the parking brake. Normal operation will return after about 1 minute.

### ■ If "Parking Brake Unavailable" is displayed on the multi-information display

Operate the parking brake switch. If the message does not disappear after operating the switch several times, the system may be malfunctioning. Have the vehicle inspected by your Toyota dealer.

### ■ Parking brake operation sound

When the parking brake operates, a motor sound (whirring sound) may be heard. This does not indicate a malfunction.

### ■ Parking brake indicator light and Parking brake switch indicator

- Depending on the power switch mode, the parking brake indicator light and the parking brake switch indicator will turn on and stay on as described below:

ON: Comes on until the parking brake is released.

Not in ON: Stays on for approximately 15 seconds.

- When the power switch is turned off with the parking brake set, the parking brake indicator light and the parking brake switch indicator will stay on for about 15 seconds. This does not indicate a malfunction.

### ■ When the parking brake switch malfunctions

Automatic mode (automatic brake setting and releasing) will be turned on automatically.

### ■ Parking the vehicle

→P.162

### ■ Parking brake engaged warning buzzer

A buzzer will sound if the vehicle is driven with the parking brake engaged. "Parking Brake ON" is displayed on the multi-information display (with the vehicle reaching a speed of 5 km/h [3 mph]).

### ■ If the brake system warning light comes on

→P.385

### ■ Usage in winter time

→P.291



## WARNING

### ■ When parking the vehicle

Do not leave a child in the vehicle alone. The parking brake may be released unintentionally by a child and there is the danger of the vehicle moving that may lead to an accident resulting in death or serious injury.

### ■ Parking brake switch

Do not set any objects near the parking brake switch. Objects may interfere with the switch and may lead the parking brake to unexpectedly operate.

### ■ Parking brake automatic lock function

Never use the automatic parking brake engagement function in place of normal parking brake operation. This function is designed to reduce the risk of a collision due to the driver forgetting to engage the parking brake. Over-reliance on this function to park the vehicle safely may lead to an accident resulting in death or serious injury. (→P.189)



## NOTICE

### ■ When parking the vehicle

Before you leave the vehicle, shift the shift lever to P, set the parking brake and make sure that the vehicle does not move.

### ■ When the system malfunctions

Stop the vehicle in a safe place and check the warning messages.

### ■ When the vehicle 12-volt battery is discharged

The parking brake system cannot be activated. (→P.408)

### ■ When the parking brake cannot be released due to a malfunction

Driving the vehicle with the parking brake set will lead to brake components overheating, which may affect braking performance and increase brake wear. Have the vehicle inspected by your Toyota dealer immediately if this occurs.



## Brake Hold

The brake hold system keeps the brake applied when the shift lever is in D, S or N with the system on and the brake pedal has been depressed to stop the vehicle. The system releases the brake when the accelerator pedal is depressed with the shift lever in D or S to allow smooth start off.

### Enabling the system

Turn the brake hold system on

The brake hold standby indicator (green) **A** comes on. While the system is holding the brake, the brake hold operated indicator (yellow) **B** comes on.

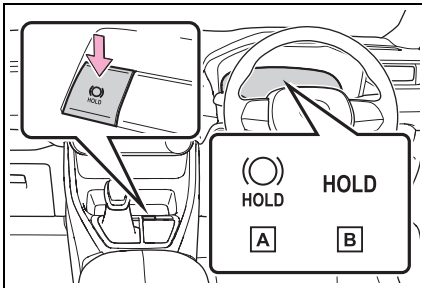

### Brake hold system operating conditions

The brake hold system cannot be turned on in the following conditions:

- The driver's door is not closed.
- The driver is not wearing the seat belt.
- The parking brake is engaged.

If any of the conditions above are detected when the brake hold system is

enabled, the system will turn off and the brake hold standby indicator light will go off. In addition, if any of the conditions are detected while the system is holding the brake, a warning buzzer will sound and a message will be shown on the multi-information display. The parking brake will then be set automatically.

### Brake hold function

- If the brake pedal is left released for a period of about 3 minutes after the system has started holding the brake, the parking brake will be set automatically. In this case, a warning buzzer sounds and a message is shown on the multi-information display.
- To turn the system off while the system is holding the brake, firmly depress the brake pedal and press the button again.
- The brake hold function may not hold the vehicle when the vehicle is on a steep incline. In this situation, it may be necessary for the driver to apply the brakes. A warning buzzer will sound and the multi-information display will inform the driver of this situation. If a warning message is shown on the multi-information display, read the message and follow the instructions.

### When the parking brake is set automatically while the system is holding the brakes

Perform any of the following operations to release the parking brake.

- Depress the accelerator pedal. (The parking brake will not be released automatically if the seat belt is not fastened.)
- Operate the parking brake switch with the brake pedal depressed.

Make sure that the parking brake indicator light goes off. (→P.187)

### When an inspection at your Toyota dealer is necessary

When the brake hold standby indicator (green) does not illuminate even when

the brake hold switch is pressed with the brake hold system operating conditions met, the system may be malfunctioning. Have the vehicle inspected at your Toyota dealer.

■ **If “Brake Hold Malfunction Press Brake to Deactivate Visit Your Dealer” or “Brake Hold Malfunction Visit Your Dealer” is displayed on the multi-information display**

The system may be malfunctioning. Have the vehicle inspected by your Toyota dealer.

■ **Warning messages and buzzers**

Warning messages and buzzers are used to indicate a system malfunction or to inform the driver of the need for caution. If a warning message is shown on the multi-information display, read the message and follow the instructions.

■ **If the brake hold operated indicator flashes**

→P.390



**NOTICE**

■ **When parking the vehicle**

The brake hold system is not designed for use when parking the vehicle for a long period of time. Turning the power switch off while the system is holding the brake may release the brake, which would cause the vehicle to move. When operating the power switch, depress the brake pedal, shift the shift lever to P and set the parking brake.



**WARNING**

■ **When the vehicle is on a steep incline**

Take care when using the brake hold system on a steep incline, exercise caution. The brake hold function may not hold brakes in such situations.

Also, the system may not activate depending on the angle of the slope.

■ **When stopped on a slippery road**

The system cannot stop the vehicle when the gripping ability of the tires has been exceeded. Do not use the system when stopped on a slippery road.

## Headlight switch





The headlights can be operated manually or automatically.

### Turning on the headlights

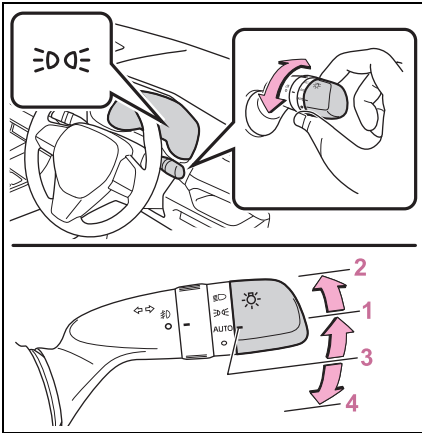
Operating the  switch turns on the lights as follows:



#### ► Type A

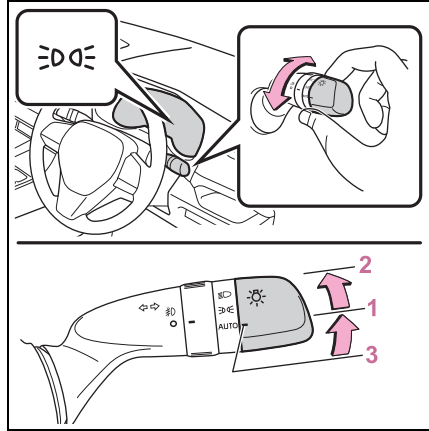

- 1  The front position, tail, license plate and instrument panel lights turn on.
- 2  The headlights and all lights listed above turn on.
- 3  The headlights, daytime running lights (→P.193) and all the lights listed above turn on and off automatically.
- 4  The daytime running lights turn on. (→P.193)

#### ► Type B



- 1  The front position, tail, license plate and instrument panel lights turn on.
- 2  The headlights and all lights listed above turn on.
- 3  The headlights, daytime running lights (→P.193) and all the lights listed above turn on and off automatically.

#### ■ AUTO mode can be used when

The power switch is in ON.

#### ■ Daytime running light system

To make your vehicle more visible to other drivers during daytime driving, the daytime running lights turn on automatically whenever the hybrid system is started and the parking brake is released with the headlight switch in the

 or AUTO position. (Illuminate brighter than the front position lights.) Daytime running lights are not designed for use at night.

#### ■ Headlight control sensor

The sensor may not function properly if

an object is placed on the sensor, or anything that blocks the sensor is affixed to the windshield. Doing so interferes with the sensor detecting the level of ambient light and may cause the automatic headlight system to malfunction.

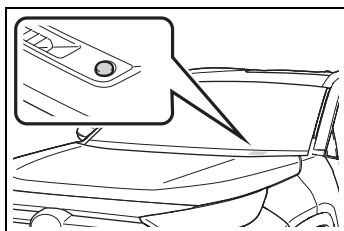



■ **Automatic light off system**

- When the headlights are on: The lights turn off 30 seconds after the power switch is turned to ACC or OFF and a door is opened and closed. (The lights turn off immediately if

 on the key is pressed after all the doors are closed.)

- When only the tail lights are on: The tail lights turn off automatically if the power switch is turned to ACC or OFF and the driver's door is opened.

To turn the lights on again, turn the power switch to ON or turn the light switch off once and then back to  or  position.

■ **Light reminder buzzer**

A buzzer sounds when the power switch is turned to OFF and the driver's door is opened while the lights are turned on.

■ **Automatic headlight leveling system**

The level of the headlights is automatically adjusted according to the number of passengers and the loading condition of the vehicle to ensure that the headlights do not interfere with other road users.

■ **12-volt Battery-saving function**

In order to prevent the 12-volt battery of the vehicle from discharging, if the headlights and/or tail lights are on when the power switch is turned to OFF, the 12-volt battery saving function will operate and automatically turn off all the lights after approximately 20 minutes.

When any of the following are performed, the 12-volt battery-saving function is canceled once and then reactivated. All the lights will turn off automatically 20 minutes after the battery-saving function has been reactivated:

- When the headlight switch is operated
- When a door is opened or closed

■ **If “Headlight System Malfunction Visit Your Dealer” is displayed on the multi-information display**

The system may be malfunctioning. Have the vehicle inspected by your Toyota dealer.

■ **Customization**

Settings (e.g. light sensor sensitivity) can be changed. (Customizable features: →P.437)

	<b>NOTICE</b>
<p>■ <b>To prevent 12-volt battery discharge</b></p> <p>Do not leave the lights on longer than necessary when the hybrid system is not running.</p>	

## Turning on the high beam headlights

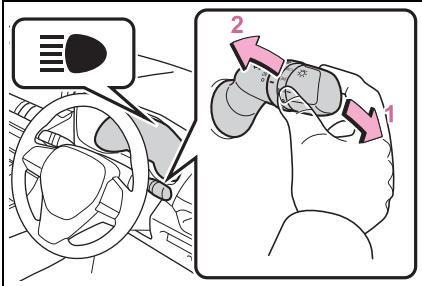

- 1 With the headlights on, push the lever away from you to turn on the high beams.

Pull the lever toward you to the center position to turn the high beams off.

- 2 Pull the lever toward you and release it to flash the high beams once.

You can flash the high beams with the headlights on or off.

## AHB (Automatic High Beam)\*

\*: If equipped

The Automatic High Beam uses an in-vehicle front camera to assess the brightness of streetlights, the lights of vehicles ahead etc., and automatically turns the high beams on or off as necessary.

### ⚠ WARNING

#### ■ Limitations of the Automatic High Beam

Do not overly rely on the Automatic High Beam. Always drive safely, taking care to observe your surroundings and turning the high beam on or off manually if necessary.

#### ■ To prevent incorrect operation of the Automatic High Beam system

Do not overload the vehicle.

## Activating the Automatic High Beam system

- 1 Press the Automatic High Beam switch.

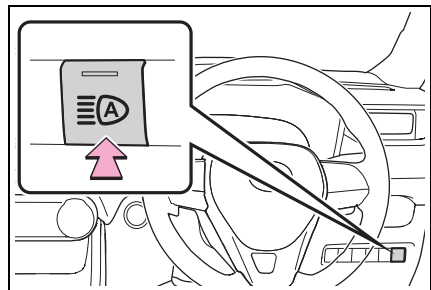

- 2 Turn the headlight switch to the AUTO or  position.

The Automatic High Beam indicator will come on when the system is operating.

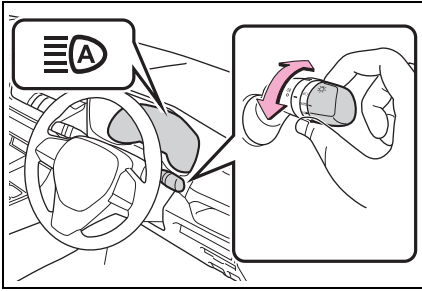

#### ■ High beams automatic turning on or off conditions

- When all of the following conditions are fulfilled, the high beams will be automatically turned on (after approximately 1 second):
  - Vehicle speed is above approximately 30 km/h (19 mph) or more.
  - The area ahead of the vehicle is dark.
  - There are no vehicles ahead with headlights or tail lights turned on.
  - There are few streetlights on the road ahead.
- If any of the following conditions are fulfilled, the high beams will be automatically turned off:
  - Vehicle speed drops below approximately 25 km/h (16 mph).
  - The area ahead of the vehicle is not dark.
  - Vehicles ahead have headlights or tail lights turned on.
  - There are many streetlights on the road ahead.

#### ■ Front camera detection information

- The high beams may not be automatically turned off in the following situations:
  - When oncoming vehicles suddenly appear from a curve
  - When the vehicle is cut in front of by another vehicle
  - When vehicles ahead are hidden from sight due to repeated curves, road dividers or roadside trees
  - When vehicles ahead appear from the

faraway lane on a wide road

- When vehicles ahead have no lights
- The high beams may be turned off if a vehicle ahead that is using fog lights without using the headlights is detected.
- House lights, street lights, traffic signals, and illuminated billboards or signs may cause the high beams to switch to the low beams, or the low beams to remain on.
- The following factors may affect the amount of time taken to turn the high beams on or off:
  - The brightness of headlights, fog lights, and tail lights of vehicles ahead
  - The movement and direction of vehicles ahead
  - When a vehicle ahead only has operational lights on one side
  - When a vehicle ahead is a two-wheeled vehicle
  - The condition of the road (gradient, curve, condition of the road surface etc.)
  - The number of passengers and amount of luggage
- The high beams may be turned on or off when the driver does not expect it.
- Bicycles or similar objects may not be detected.
- In the situations shown below, the system may not be able to accurately detect surrounding brightness levels. This may cause the low beams to remain on or the high beams to cause problems for pedestrians, vehicles ahead or other parties. In these cases, manually switch between the high and low beams.
  - In bad weather (rain, snow, fog, sandstorms, etc.)
  - The windshield is obscured by fog, mist, ice, dirt, etc.
  - The windshield is cracked or damaged
  - The front camera is deformed or dirty
  - When the temperature of the front camera is extremely high
  - Surrounding brightness levels are

equal to those of headlights, tail lights or fog lights

- When headlights or tail lights of vehicles ahead are turned off, dirty, changing color, or not aimed properly
- When the vehicle is hit by water, snow, dust, etc. from a preceding vehicle
- When driving through an area of intermittently changing brightness and darkness
- When frequently and repeatedly driving ascending/descending roads, or roads with rough, bumpy or uneven surfaces (such as stone-paved roads, gravel roads, etc.)
- When frequently and repeatedly taking curves or driving on a winding road
- There is a highly reflective object ahead of the vehicle, such as a sign or mirror
- The back of a vehicle ahead is highly reflective, such as a container on a truck
- The vehicle's headlights are damaged or dirty, or are not aimed properly
- The vehicle is listing or tilting due to a flat tire, a trailer being towed, etc.
- The high beams and low beams are repeatedly being switched between in an abnormal manner
- The driver believes that the high beams may be causing problems or distress to other drivers or pedestrians nearby

■ **If “Headlight System Malfunction Visit Your Dealer” is displayed on the multi-information display**

The system may be malfunctioning. Have the vehicle inspected by your Toyota dealer.

### Turning the high beams on/off manually

■ **Switching to the high beams**

Push the lever away from you.

The Automatic High Beam indicator will

turn off and the headlight high beam indicator will turn on.

Pull the lever to its original position to activate the Automatic High Beam system again.

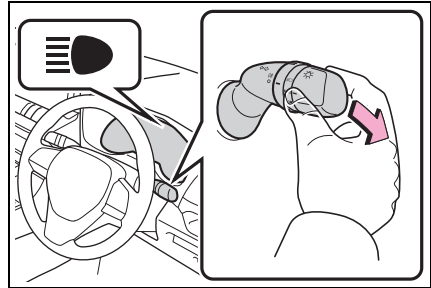

■ **Switching to the low beams**

Press the Automatic High Beam switch.

The Automatic High Beam indicator will turn off.

Press the switch to activate the Automatic High Beam system again.

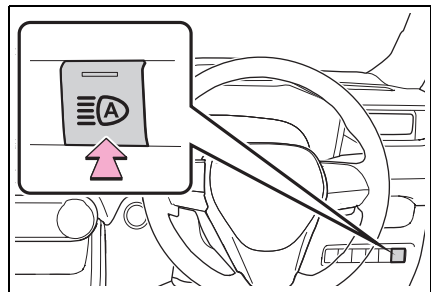

■ **Temporarily switching to the low beams**

Pull the lever toward you and then return it to its original position.

The high beams are on while the lever is pulled toward you, however, after the lever is returned to its original position, the low beams remain on for a certain amount of time. Afterwards, the Auto-

matic High Beam will be activated again.

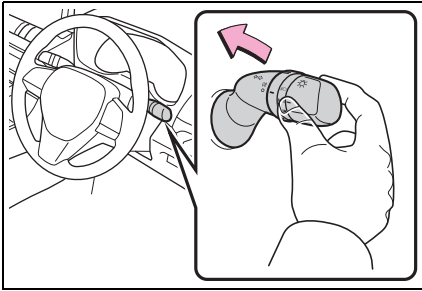

#### ■ Temporarily switching to the low beams

It is recommended to switch to the low beams when the high beams may cause problems or distress to other drivers or pedestrians nearby.

## Fog light switch

The fog lights offer improved visibility in difficult driving conditions, such as in rain and fog.

## Operating procedure

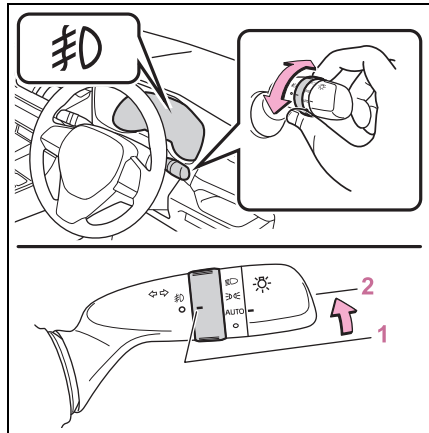

- 1 ○ Turns the fog lights off
- 2 ⦿ Turns the fog lights on

#### ■ Fog lights can be used when

The headlights or the front position lights are turned on.



## Windshield wipers and washer

Operating the lever can switch between automatic operation and manual operation, or can use the washer.



### NOTICE





**■ When the windshield is dry**

Do not use the wipers, as they may damage the windshield.

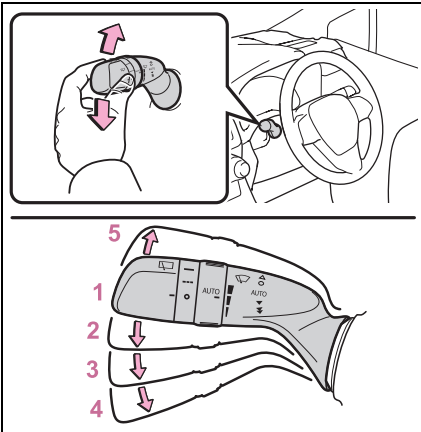
## Operating the wiper lever

Operating the  lever operates the wipers or washer as follows:



- 1  Off
- 2 AUTO Rain-sensing operation
- 3  Low speed operation
- 4  High speed operation
- 5  Temporary operation

When "AUTO" is selected, the wipers will operate automatically when the

sensor detects falling rain. The system automatically adjusts wiper timing in accordance with rain volume and vehicle speed.

The sensor sensitivity can be adjusted when "AUTO" is selected.

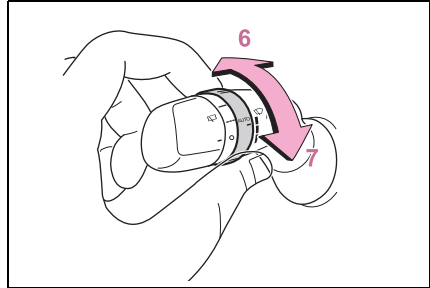

- 6 Increases the sensitivity
- 7 Decreases the sensitivity

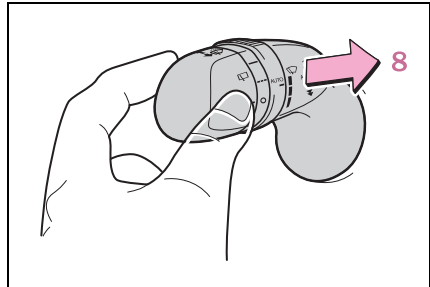

- 8  Washer/wiper dual operation

Pulling the lever operates the wipers and washer.

The wipers will automatically operate a couple of times after the washer squirts.

**■ The windshield wipers and washer can be operated when**

The power switch is in ON.

**■ Effects of vehicle speed on wiper operation**

With low speed windshield wiper opera-

tion selected, wiper operation will be switched from low speed to intermittent wiper operation when the vehicle is stationary. (However, when the sensor sensitivity is adjusted to the highest level, the mode will not switch.)

#### ■ Raindrop sensor

- The raindrop sensor judges the amount of raindrops.

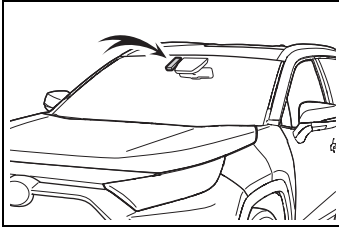

- If the wiper switch is turned to the "AUTO" position while the power switch is in ON, the wipers will operate once to show that "AUTO" mode is activated.
- If the wiper sensitivity is adjusted to higher, the wiper may operate once to indicate the change of sensitivity.
- If the temperature of the raindrop sensor is 85°C (185°F) or higher, or -15°C (5°F) or lower, the automatic operation may not occur. In this case, operate the wipers in any mode other than "AUTO".

#### ■ If no windshield washer fluid sprays

Check that the washer nozzles are not blocked if there is washer fluid in the windshield washer fluid reservoir.

### ⚠ WARNING

#### ■ Caution regarding the use of windshield wipers in "AUTO" mode

The windshield wipers may operate unexpectedly if the sensor is touched or the windshield is subject to vibration in "AUTO" mode. Take care that your fingers or anything else does not become caught in the windshield wipers.

#### ■ Caution regarding the use of washer fluid

When it is cold, do not use the washer fluid until the windshield becomes warm. The fluid may freeze on the windshield and cause low visibility. This may lead to an accident, resulting in death or serious injury.

### ⚠ NOTICE

#### ■ When the washer fluid tank is empty

Do not operate the switch continually as the washer fluid pump may overheat.

#### ■ When a nozzle becomes blocked

In this case, contact your Toyota dealer.

Do not try to clear it with a pin or other object. The nozzle will be damaged.

#### ■ To prevent 12-volt battery discharge

Do not leave the wipers on longer than necessary when the hybrid system is off.

## Rear window wiper and washer

The rear window wiper and washer can be used by operating the lever.



### NOTICE



#### ■ When the rear window is dry

Do not use the wiper, as it may damage the rear window.

## Operating the wiper lever

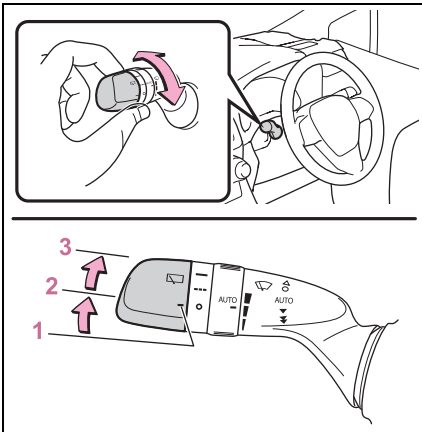
Operating the  switch operates the rear wiper as follows:



- 1  Off
- 2  Intermittent operation
- 3  Normal operation

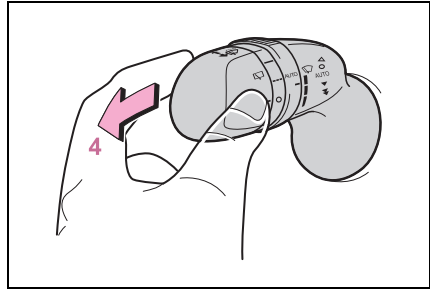

#### 4 Washer/wiper dual operation

Pushing the lever operates the wiper and washer.

The wiper will automatically operate a couple of times after the washer squirts.

#### ■ The rear window wiper and washer can be operated when

The power switch is in ON.

#### ■ If no washer fluid sprays

Check that the washer nozzle is not blocked if there is washer fluid in the washer fluid reservoir.

#### ■ Back door opening linked rear window wiper stop function

When the rear window wiper is operating, if the back door is opened while the vehicle is stopped, operation of the rear window wiper will be stopped to prevent anyone near the vehicle from being sprayed by water from the wiper. When the back door is closed, wiper operation will resume.\*

\*: The setting must be customized at your Toyota dealer.

#### ■ Reverse-linked rear window wiper function

When the shift lever is shifted to R when the front wipers are operating, the rear window wiper will operate once.

#### ■ Customization

Setting of the reverse-linked function

can be changed.

(Customizable features: →P.438)

**NOTICE****■ When the washer fluid tank is empty**

Do not operate the switch continually as the washer fluid pump may overheat.

**■ When a nozzle becomes blocked**

In this case, contact your Toyota dealer.  
Do not try to clear it with a pin or other object. The nozzle will be damaged.

**■ To prevent 12-volt battery discharge**

Do not leave the wiper on longer than necessary when the hybrid system is off.

## Opening the fuel tank cap

Perform the following steps to open the fuel tank cap:

### Before refueling the vehicle

- Close all the doors and windows, and turn the power switch to OFF.
- Confirm the type of fuel.

#### Fuel types

→P.428

#### Fuel tank opening for unleaded gasoline

To help prevent incorrect fueling, your vehicle has a fuel tank opening that only accommodates the special nozzle on unleaded fuel pumps.



### WARNING

#### When refueling the vehicle

Observe the following precautions while refueling the vehicle. Failure to do so may result in death or serious injury.

- After exiting the vehicle and before opening the fuel door, touch an unpainted metal surface to discharge any static electricity. It is important to discharge static electricity before refueling because sparks resulting from static electricity can cause fuel vapors to ignite while refueling.

- Always hold the grips on the fuel tank cap and turn it slowly to remove it. A whooshing sound may be heard when the fuel tank cap is loosened. Wait until the sound cannot be heard before fully removing the cap. In hot weather, pressurized fuel may spray out of the filler neck and cause injury.
- Do not allow anyone that has not discharged static electricity from their body to come close to an open fuel tank.
- Do not inhale vaporized fuel. Fuel contains substances that are harmful if inhaled.
- Do not smoke while refueling the vehicle. Doing so may cause the fuel to ignite and cause a fire.
- Do not return to the vehicle or touch any person or object that is statically charged. This may cause static electricity to build up, resulting in a possible ignition hazard.

#### When refueling

Observe the following precautions to prevent fuel overflowing from the fuel tank:

- Securely insert the fuel nozzle into the fuel filler neck.
- Stop filling the tank after the fuel nozzle automatically clicks off.
- Do not top off the fuel tank.



### NOTICE

#### Refueling

Do not spill fuel during refueling. Doing so may damage the vehicle, such as causing the emission control system to operate abnormally or damaging fuel system components or the vehicle's painted surface.

## Opening the fuel tank cap

- 1 Press the opener to open the fuel filler door.

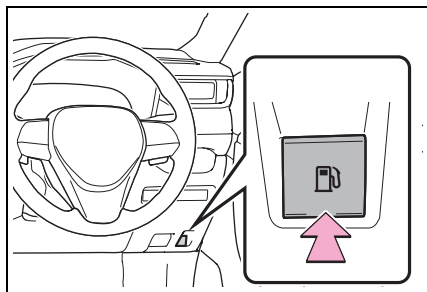

- 2 Turn the fuel tank cap slowly to open it and put it into the holder on the fuel filler door.

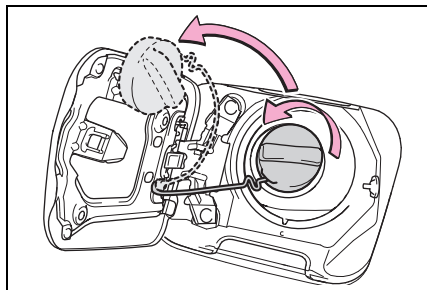

- If the fuel filler door cannot be opened

→P.406

## Closing the fuel tank cap

After refueling, turn the fuel tank cap until you hear a click. Once the cap is released, it will turn slightly in the opposite direction.

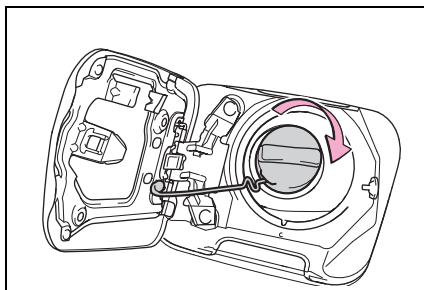

### WARNING

#### ■ When replacing the fuel tank cap

Do not use anything but a genuine Toyota fuel tank cap designed for your vehicle. Doing so may cause a fire or other incident which may result in death or serious injury.

## Toyota Safety Sense\*

\*: If equipped

The Toyota Safety Sense consists of the following drive assist systems and contributes to a safe and comfortable driving experience:

### Driving assist system

#### ■ PCS (Pre-Collision System)

→P.210

#### ■ LTA (Lane Tracing Assist)

→P.220

#### ■ AHB (Automatic High Beam)

→P.195

#### ■ RSA (Road Sign Assist)

→P.231

#### ■ Dynamic radar cruise control with full-speed range

→P.234



### WARNING

#### ■ Toyota Safety Sense

The Toyota Safety Sense is designed to operate under the assumption that the driver will drive safely, and is designed to help reduce the impact to the occupants and the vehicle in the case of a collision or assist the driver in normal driving conditions. As there is a limit to the degree of recognition accuracy and control performance that this system can provide, do not overly rely on this system. The driver is always responsible for paying attention to the vehicle's surroundings and driving safely.

## Sensors

Two types of sensors, located behind the front grille and windshield, detect information necessary to operate the drive assist systems.

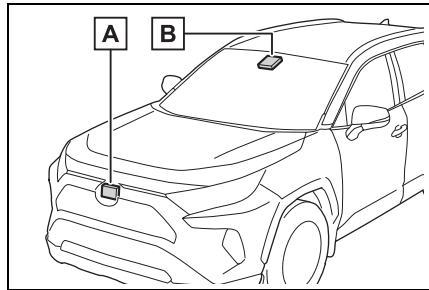

A Radar sensor

B Front camera



### WARNING

#### ■ To avoid malfunction of the radar sensor

Observe the following precautions. Otherwise, the radar sensor may not operate properly, possibly leading to an accident resulting in death or serious injury.

**WARNING**

- Keep the radar sensor and the radar sensor cover clean at all times.

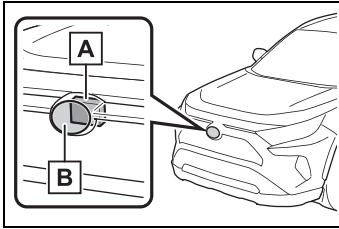

**A** Radar sensor

**B** Radar sensor cover

If the front of the radar sensor or the front or back of the radar sensor cover is dirty or covered with water droplets, snow, etc., clean it.

Clean the radar sensor and radar sensor cover with a soft cloth to avoid damaging them.

- Do not attach accessories, stickers (including transparent stickers) or other items to the radar sensor, radar sensor cover or surrounding area.
- Do not subject the radar sensor or its surrounding area to a strong impact.  
If the radar sensor, front grille, or front bumper has been subjected to a strong impact, have the vehicle inspected by your Toyota dealer.
- Do not disassemble the radar sensor.
- Do not modify or paint the radar sensor or radar sensor cover.

- In the following cases, the radar sensor must be recalibrated. Contact your Toyota dealer for details.
  - When the radar sensor or front grille are removed and installed, or replaced
  - When the front bumper is replaced

**■ To avoid malfunction of the front camera**

Observe the following precautions. Otherwise, the front camera may not operate properly, possibly leading to an accident resulting in death or serious injury.

- Keep the windshield clean at all times.
  - If the windshield is dirty or covered with an oily film, water droplets, snow, etc., clean the windshield.
  - If a glass coating agent is applied to the windshield, it will still be necessary to use the windshield wipers to remove water droplets, etc. from the area of the windshield in front of the front camera.
  - If the inner side of the windshield where the front camera is installed is dirty, contact your Toyota dealer.



## ⚠ WARNING

- Do not attach objects, such as stickers, transparent stickers, etc., to the outer side of the windshield in front of the front camera (shaded area in the illustration).

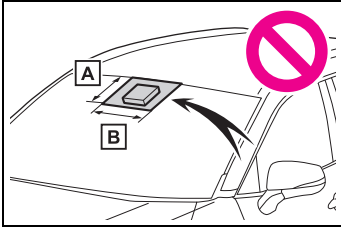

- A** From the top of the windshield to approximately 1 cm (0.4 in.) below the bottom of the front camera
- B** Approximately 20 cm (7.9 in.) (Approximately 10 cm [4.0 in.] to the right and left from the center of the front camera)
- If the part of the windshield in front of the front camera is fogged up or covered with condensation or ice, use the windshield defogger to remove the fog, condensation or ice. (→P.299)
- If water droplets cannot be properly removed from the area of the windshield in front of the front camera by the windshield wipers, replace the wiper insert or wiper blade.
- Do not attach window tint to the windshield.
- Replace the windshield if it is damaged or cracked.  
After replacing the windshield, the front camera must be recalibrated. Contact your Toyota dealer for details.
- Do not allow liquids to contact the front camera.

- Do not allow bright lights to shine into the front camera.
- Do not dirty or damage the front camera.  
When cleaning the inside of the windshield, do not allow glass cleaner to contact the lens of the front camera. Also, do not touch the lens.  
If the lens is dirty or damaged, contact your Toyota dealer.
- Do not subject the front camera to a strong impact.
- Do not change the installation position or direction of the front camera or remove it.
- Do not disassemble the front camera.
- Do not modify any components of the vehicle around the front camera (inside rear view mirror, etc.) or ceiling.
- Do not attach any accessories to the hood, front grille or front bumper that may obstruct the front camera. Contact your Toyota dealer for details.
- If a surfboard or other long object is to be mounted on the roof, make sure that it will not obstruct the front camera.
- Do not modify the headlights or other lights.

### ■ If a warning message is displayed on the multi-information display

A system may be temporarily unavailable or there may be a malfunction in the system.

- In the following situations, perform the actions specified in the table. When the normal operating conditions are detected, the message will disappear and the system will become operational.

If the message does not disappear, contact your Toyota dealer.

Situation	Actions
When the area around a camera is covered with dirt, moisture (fogged up, covered with condensation, ice, etc.), or other foreign matter	Using the wiper and A/C function, remove the dirt and other attached matter. (→P.299)
When the temperature around the front camera is outside of the operational range, such as when the vehicle is in the sun or in an extremely cold environment	If the front camera is hot, such as after the vehicle had been parked in the sun, use the air conditioning system to decrease the temperature around the front camera.  If a sunshade was used when the vehicle was parked, depending on its type, the sunlight reflected from the surface of the sunshade may cause the temperature of the front camera to become excessively high.
	If the front camera is cold, such after the vehicle is parked in an extremely cold environment, use the air conditioning system to increase the temperature around the front camera.
The area in front of the front camera is obstructed, such as when the hood is open or a sticker is attached to the part of the windshield in front of the front camera.	Close the hood, remove the sticker, etc. to clear the obstruction.
When “Pre-Collision System Radar In Self Calibration Unavailable See Owner’s Manual” is displayed.	Check whether there is attached materials on the radar sensor and radar sensor cover, and if there is, remove it.

- In the following situations, if the situation has changed (or the vehicle has been driven for some time) and the normal operating conditions are detected, the message will disappear and the system will become operational.

If the message does not disappear, contact your Toyota dealer.

- When the temperature around the radar sensor is outside of the operational range, such as when the vehicle is in the sun or in an extremely cold environment
- When the front camera cannot detect objects in front of the vehicle, such as when driving in the dark, snow, or fog, or when bright lights are shining into the front camera
- Depending on the conditions in the vicinity of the vehicle, the radar may judge the surrounding environment can not be properly recognized. In that case, "Pre-Collision System Unavailable See Owner's Manual" is displayed.

## PCS (Pre-Collision System)\*

\*: If equipped

The pre-collision system uses a radar sensor and front camera to detect objects (→P.210) in front of the vehicle. When the system determines that the possibility of a frontal collision with an object is high, a warning operates to urge the driver to take evasive action and the potential brake pressure is increased to help the driver avoid the collision. If the system determines that the possibility of a frontal collision with an object is extremely high, the brakes are automatically applied to help avoid the collision or help reduce the impact of the collision.

The pre-collision system can be disabled/enabled and the warning timing can be changed. (→P.213)

### Detectable objects

The system can detect the following (The detectable objects differs depending on the function.):

- Vehicles
- Bicyclists
- Pedestrians

## System functions

### ■ Pre-collision warning

When the system determines that the possibility of a frontal collision is high, a buzzer will sound and a warning message will be displayed on the multi-information display to urge the driver to take evasive action.

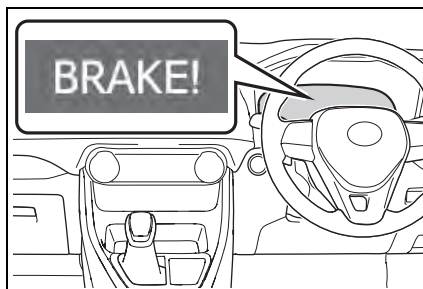

### ■ Pre-collision brake assist

When the system determines that the possibility of a frontal collision is high, the system applies greater braking force in relation to how strongly the brake pedal is depressed.

### ■ Pre-collision braking

If the system determines that the possibility of a frontal collision is extremely high, the brakes are automatically applied to help avoid the collision or reduce the impact of the collision.

### ■ Emergency steering assist

If the system determines that the possibility of a collision with a pedestrian is high and that there is sufficient space for the vehicle to be

steered into within its lane, and the driver has begun evasive maneuver or steering, emergency steering assist will assist the steering movements to help enhance the vehicle stability and for lane departure prevention. During operation, the indicator will illuminate in green.

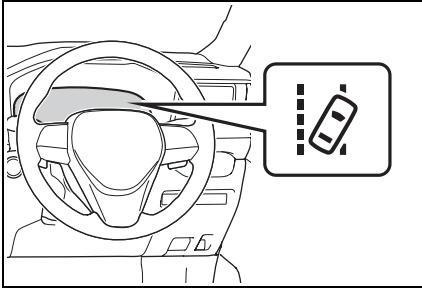

#### ■ Intersection right/left turn assistance

If the system determines that there is a high possibility of a collision in the following situations, it will assist with Pre-collision warning and, if necessary Pre-collision braking.

Depending on the configuration of the intersection, it may not be possible to support.

- When you turn right/left at an intersection and cross the path of an oncoming vehicle

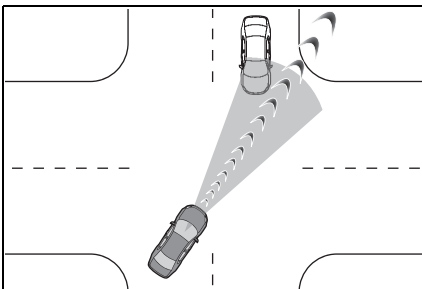

- When you turn right/left, pedestrian is detected in the forward direction and estimated to enter your vehicle's path (bicyclists are not detected.)

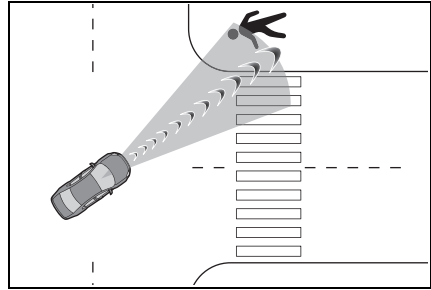

#### ⚠ WARNING

##### ■ Limitations of the pre-collision system

- The driver is solely responsible for safe driving. Always drive safely, taking care to observe your surroundings. Do not use the pre-collision system instead of normal braking operations under any circumstances. This system will not prevent collisions or lessen collision damage or injury in every situation. Do not overly rely on this system. Failure to do so may lead to an accident, resulting in death or serious injury.



## WARNING

- Although this system is designed to help avoid a collision or help reduce the impact of the collision, its effectiveness may change according to various conditions, therefore the system may not always be able to achieve the same level of performance.  
Read the following conditions carefully. Do not overly rely on this system and always drive carefully.
  - Conditions under which the system may operate even if there is no possibility of a collision: →P.216
  - Conditions under which the system may not operate properly: →P.218
  - Do not attempt to test the operation of the pre-collision system yourself. Depending on the objects used for testing (dummies, cardboard objects imitating detectable objects, etc.), the system may not operate properly, possibly leading to an accident.
- Pre-collision braking**
- When the pre-collision braking function is operating, a large amount of braking force will be applied.
  - If the vehicle is stopped by the operation of the pre-collision braking function, the pre-collision braking function operation will be canceled after approximately 2 seconds. Depress the brake pedal as necessary.
  - The pre-collision braking function may not operate if certain operations are performed by the driver. If the accelerator pedal is being depressed strongly or the steering wheel is being turned, the system may determine that the driver is taking evasive action and possibly prevent the pre-collision braking function from operating.

- In some situations, while the pre-collision braking function is operating, operation of the function may be canceled if the accelerator pedal is depressed strongly or the steering wheel is turned and the system determines that the driver is taking evasive action.
  - If the brake pedal is being depressed, the system may determine that the driver is taking evasive action and possibly delay the operation timing of the pre-collision braking function.
- Emergency steering assist**
- As emergency steering assist operation will be canceled when the system determines that lane departure prevention function has been completed.
  - Emergency steering assist may not operate or may be cancel in the following cases as the system may determine the driver is taking actions.
  - If the accelerator pedal is being depressed strongly, the steering wheel is being operated sharply, the brake pedal is being depressed or the turn signal lever is being operated. In this case, the system may determine that the driver is taking evasive action and the emergency steering assist may not operate.
  - In some situations, while the emergency steering assist is operating, operation of the function may be canceled if the accelerator pedal is depressed strongly, the steering wheel is operated sharply or the brake pedal is being depressed and the system determines that the driver is taking evasive action.

**WARNING**

- When the emergency steering assist is operating, if the steering wheel is held firmly or is operated in the opposite direction to that which the system is generating torque, the function may be canceled.

**■ When to disable the pre-collision system**

In the following situations, disable the system, as it may not operate properly, possibly leading to an accident resulting in death or serious injury:

- When the vehicle is being towed
- When your vehicle is towing another vehicle
- When transporting the vehicle via truck, boat, train or similar means of transportation
- When the vehicle is raised on a lift with the hybrid system on and the tires are allowed to rotate freely
- When inspecting the vehicle using a drum tester such as a chassis dynamometer or speedometer tester, or when using an on vehicle wheel balancer
- When a strong impact is applied to the front bumper or front grille, due to an accident or other reasons
- If the vehicle cannot be driven in a stable manner, such as when the vehicle has been in an accident or is malfunctioning
- When the vehicle is driven in a sporty manner or off-road
- When the tires are not properly inflated
- When the tires are very worn
- When tires of a size other than specified are installed
- When tire chains are installed

- When a compact spare tire or an emergency tire puncture repair kit is used
- If equipment (snow plow, etc.) that may obstruct the radar sensor or front camera is temporarily installed to the vehicle

**Changing settings of the pre-collision system****■ Enabling/disabling the pre-collision system**

The pre-collision system can be enabled/disabled on the  screen (→P.94, 103) of the multi-information display.

The system is automatically enabled each time the power switch is turned to ON.

If the system is disabled, the PCS warning light will turn on and a message will be displayed on the multi-information display.

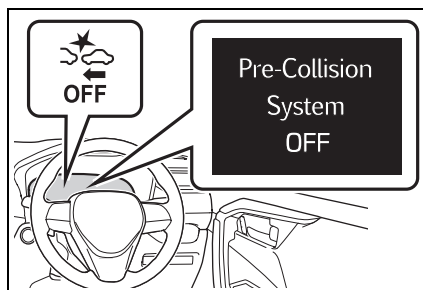
**■ Changing the pre-collision warning timing**

The pre-collision warning timing can be changed on the  screen (→P.94, 103) of the multi-information display.

The warning timing setting is retained when the power switch is turned to OFF. However, if the pre-collision system is disabled and re-enabled, the operation timing will return to the default setting (middle).

If the pre-collision warning timing is changed, emergency steering assist timing will also be changed accordingly.

If late is selected, emergency steering assist would not operate in case of an emergency.

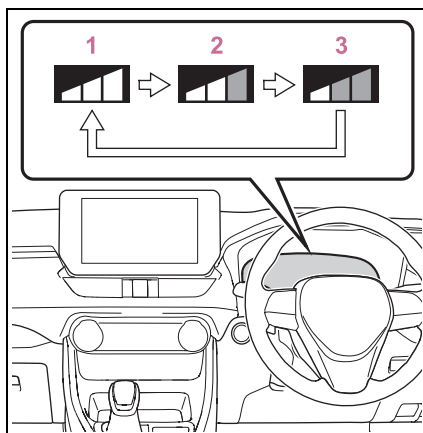

1 Early

2 Middle

This is the default setting.

3 Late

**Operational conditions for each pre-collision function**

The pre-collision system is enabled and the system determines that the possibility of a frontal collision with a detected object is high.

The system may not operate in the following situations:

- If a 12-volt battery terminal has been disconnected and reconnected and then the vehicle has not been driven for a certain amount of time
- If the shift lever is in R
- When the VSC OFF indicator is illuminated (only the pre-collision warning function will be operational)

The operation speeds and operation cancellation for each function is listed below.

● Pre-collision warning

Detectable objects	Vehicle speed	Relative speed between your vehicle and object
Vehicles	Approx. 10 to 180 km/h (7 to 110 mph)	Approx. 10 to 180 km/h (7 to 110 mph)
Bicyclists and pedestrians	Approx. 10 to 80 km/h (7 to 50 mph)	Approx. 10 to 80 km/h (7 to 50 mph)

While the pre-collision warning function is operating, if the steering wheel is operated heavily or suddenly, the pre-collision warning may be canceled.



● Pre-collision brake assist

Detectable objects	Vehicle speed	Relative speed between your vehicle and object
Vehicles	Approx. 30 to 180 km/h (20 to 110 mph)	Approx. 30 to 180 km/h (20 to 110 mph)
Bicyclists and pedestrians	Approx. 30 to 80 km/h (20 to 50 mph)	Approx. 30 to 80 km/h (20 to 50 mph)

● Pre-collision braking

Detectable objects	Vehicle speed	Relative speed between your vehicle and object
Vehicles	Approx. 10 to 180 km/h (7 to 110 mph)	Approx. 10 to 180 km/h (7 to 110 mph)
Bicyclists and pedestrians	Approx. 10 to 80 km/h (7 to 50 mph)	Approx. 10 to 80 km/h (7 to 50 mph)

If either of the following occur while the pre-collision braking function is operating, it will be canceled:

- The accelerator pedal is depressed strongly.
- The steering wheel is turned sharply or abruptly.

● Emergency steering assist

When the turn signal lights are flashing, emergency steering assist will not operate in case of an emergency.

Detectable objects	Vehicle speed	Relative speed between your vehicle and object
Pedestrians	Approx. 40 to 80 km/h (25 to 50 mph)	Approx. 40 to 80 km/h (25 to 50 mph)

If any of the following occur while the emergency steering assist function is operating, it will be canceled:

- The accelerator pedal is depressed strongly.
  - The steering wheel is turned sharply or abruptly.
  - The brake pedal is depressed.
- Intersection right/left turn assistance (pre-collision warning)

When the turn signal lights are not flashing, support for turning left or right at an intersection which targets oncoming vehicles does not work.

Detectable objects	Vehicle speed	Oncoming vehicle speed	Relative speed between your vehicle and object
Vehicles	Approx. 10 to 25 km/h (7 to 15 mph)	Approx. 30 to 55 km/h (20 to 35 mph)	Approx. 40 to 80 km/h (25 to 50 mph)
Pedestrians	Approx. 10 to 25 km/h (7 to 15 mph)	—	Approx. 10 to 25 km/h (7 to 15 mph)

● Intersection right/left turn assistance (pre-collision braking)

When the turn signal lights are not flashing, support for turning left or right at an intersection which targets oncoming vehicles does not work.

Detectable objects	Vehicle speed	Oncoming vehicle speed	Relative speed between your vehicle and object
Vehicles	Approx. 15 to 25 km/h (10 to 15 mph)	Approx. 30 to 45 km/h (20 to 28 mph)	Approx. 45 to 70 km/h (28 to 43 mph)
Pedestrians	Approx. 10 to 25 km/h (7 to 15 mph)	—	Approx. 10 to 25 km/h (7 to 15 mph)

■ Object detection function

The system detects objects based on their size, profile, motion, etc. However, an object may not be detected depending on the surrounding brightness and the motion, posture, and angle of the detected object, preventing the system from operating properly. (→P.218)  
The illustration shows an image of detectable objects.

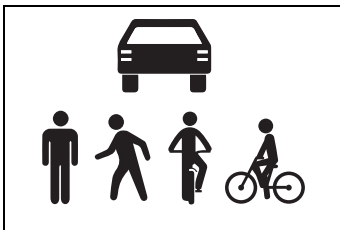

■ Conditions under which the system may operate even if there is no possibility of a collision

- In some situations such as the following, the system may determine that there is a possibility of a frontal collision and operate.
- When passing a detectable object,

etc.

- When changing lanes while overtaking a detectable object, etc.
- When approaching a detectable object in an adjacent lane or on the roadside, such as when changing the course of travel or driving on a winding road

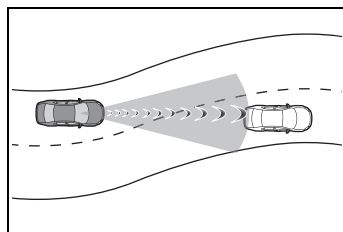

- When rapidly closing on a detectable object, etc.
- When approaching objects on the roadside, such as detectable objects, guardrails, utility poles, trees, or walls
- When there is a detectable object or other object by the roadside at the entrance of a curve

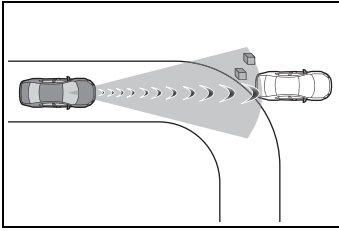

- When there are patterns or paint in front of your vehicle that may be mistaken for a detectable object
- When the front of your vehicle is hit by water, snow, dust, etc.
- When overtaking a detectable object that is changing lanes or making a right/left turn

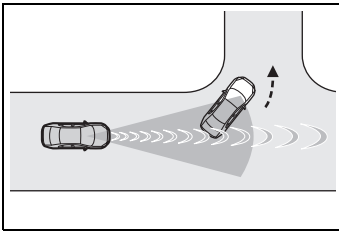

- When passing a detectable object in an oncoming lane that is stopped to make a right/left turn

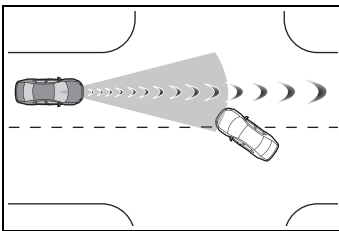

- When a detectable object approaches very close and then stops before entering the path of your vehicle
- If the front of your vehicle is raised or lowered, such as when on an uneven or undulating road surface
- When driving on a road surrounded by a structure, such as in a tunnel or on an iron bridge
- When there is a metal object (man-hole cover, steel plate, etc.), steps, or a protrusion in front of your vehicle
- When passing under an object (road

sign, billboard, etc.)

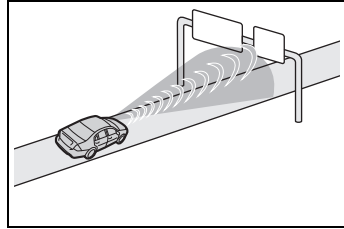

- When approaching an electric toll gate barrier, parking area barrier, or other barrier that opens and closes
- When using an automatic car wash
- When driving through or under objects that may contact your vehicle, such as thick grass, tree branches, or a banner

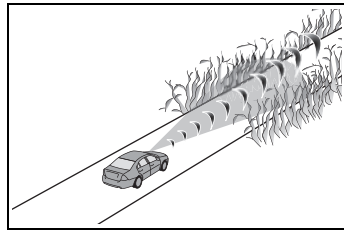

- When driving through steam or smoke
- When driving near an object that reflects radio waves, such as a large truck or guardrail
- When driving near a TV tower, broadcasting station, electric power plant, radar equipped vehicles, etc., or other location where strong radio waves or electrical noise may be present
- When there are many things which can reflect the radio waves of the radar in the vicinity (tunnels, truss bridges, gravel roads, snow covered road that have tracks, etc.)
- While making a right/left turn, when an oncoming vehicle or a crossing pedestrian has already exited the path of your vehicle
- While making a right/left turn, closely in front of an oncoming vehicle or a crossing pedestrian.
- While making a right/left turn, when an oncoming vehicle or a crossing pedestrian stops before entering the

path of your vehicle

- While making a right/left turn, when an oncoming vehicle turns right/left in front of your vehicle

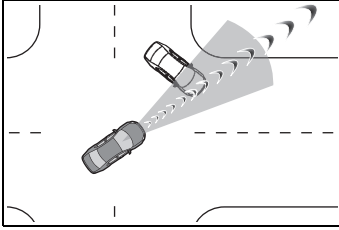

- While steering into the direction of oncoming traffic

### ■ Situations in which the system may not operate properly

- In some situations such as the following, an object may not be detected by the radar sensor and front camera, preventing the system from operating properly:

- When a detectable object is approaching your vehicle
- When your vehicle or a detectable object is wobbling
- If a detectable object makes an abrupt maneuver (such as sudden swerving, acceleration or deceleration)
- When your vehicle approaches a detectable object rapidly
- When a detectable object is not directly in front of your vehicle

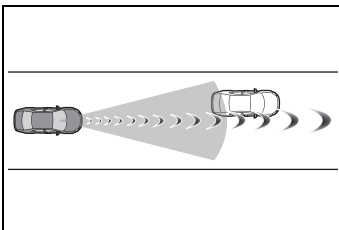

- When a detectable object is near a wall, fence, guardrail, manhole cover, vehicle, steel plate on the road, etc.
- When a detectable object is under a structure
- When part of a detectable object is hidden by an object, such as large baggage, an umbrella, or guardrail

- When there are many things which can reflect the radio waves of the radar in the vicinity (tunnels, truss bridges, gravel roads, snow covered road that have tracks, etc.)
- When there is an effect on the radio waves to the radar that is installed on another vehicle
- When multiple detectable objects are close together
- If the sun or other light is shining directly on a detectable object
- When a detectable object is a shade of white and looks extremely bright
- When a detectable object appears to be nearly the same color or brightness as its surroundings
- If a detectable object cuts or suddenly emerges in front of your vehicle
- When the front of your vehicle is hit by water, snow, dust, etc.
- When a very bright light ahead, such as the sun or the headlights of oncoming traffic, shines directly into the front camera
- When approaching the side or front of a vehicle ahead
- If a vehicle ahead is a motorcycle
- If a vehicle ahead is narrow, such as a personal mobility vehicle
- If a preceding vehicle has a small rear end, such as an unloaded truck
- If a preceding vehicle has a low rear end, such as a low bed trailer

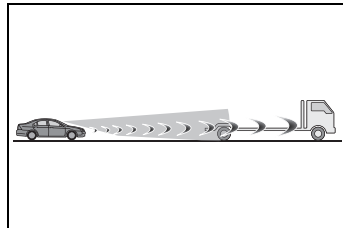

- If a vehicle ahead has extremely high ground clearance

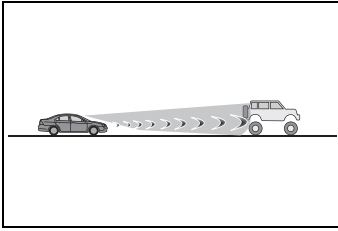

- If a vehicle ahead is carrying a load which protrudes past its rear bumper
- If a vehicle ahead is irregularly shaped, such as a tractor or side car
- If a vehicle ahead is a child sized bicycle, a bicycle that is carrying a large load, a bicycle ridden by more than one person, or a uniquely shaped bicycle (bicycle with a child seat, tandem bicycle, etc.)
- If a pedestrian/or the riding height of a bicyclist ahead is shorter than approximately 1 m (3.2 ft.) or taller than approximately 2 m (6.5 ft.)
- If a pedestrian/bicyclist is wearing oversized clothing (a rain coat, long skirt, etc.), making their silhouette obscure
- If a pedestrian is bending forward or squatting or bicyclist is bending forward
- If a pedestrian/bicyclist is moving fast
- If a pedestrian is pushing a stroller, wheelchair, bicycle or other vehicle
- When driving in inclement weather such as heavy rain, fog, snow or a sandstorm
- When driving through steam or smoke
- When the surrounding area is dim, such as at dawn or dusk, or while at night or in a tunnel, making a detectable object appear to be nearly the same color as its surroundings
- When driving in a place where the surrounding brightness changes suddenly, such as at the entrance or exit of a tunnel
- After the hybrid system has started the vehicle has not been driven for a certain amount of time
- While making a left/right turn and for a few seconds after making a left/right turn

- While driving on a curve and for a few seconds after driving on a curve
- If your vehicle is skidding
- If the front of the vehicle is raised or lowered

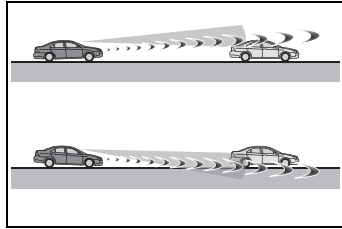

- If the wheels are misaligned
- If a wiper blade is blocking the front camera
- The vehicle is being driven at extremely high speeds
- When driving on a hill
- If the radar sensor or front camera is misaligned
- When driving in a traffic lane separated by more than one lane where oncoming vehicles are driving while making a right/left turn
- When largely out of place with the opposite facing targeted oncoming vehicle during a right/left turn

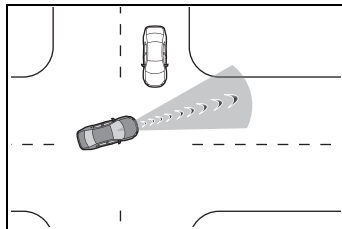

- While making a right/left turn, when a pedestrian approaches from behind or side of your vehicle

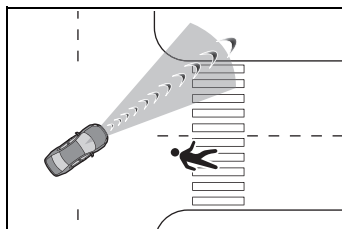

- In addition to the above, in some situ-

ations, such as the following, the emergency steering assist may not operate.

- When the white (yellow) lane lines are difficult to see, such as when they are faint, diverging/merging, or a shadow is cast upon them
- When the lane is wider or narrower than normal
- When there is a light and dark pattern on the road surface, such as due to road repairs
- When a pedestrian is detected near the centerline of the vehicle
- When the target is too close
- When there is insufficient safe or unobstructed space for the vehicle to be steered into
- If oncoming vehicle is present
- If VSC function is operating
- In some situations such as the following, sufficient braking force or steering force may not be obtained, preventing the system from performing properly:
  - If the braking functions cannot operate to their full extent, such as when the brake parts are extremely cold, extremely hot, or wet
  - If the vehicle is not properly maintained (brakes or tires are excessively worn, improper tire inflation pressure, etc.)
  - When the vehicle is being driven on a gravel road or other slippery surface
  - When the road surface has deep wheel tracks
  - When driving on a hill road
  - When driving on a road that has inclines to the left or right

#### ■ If VSC is disabled

- If VSC is disabled (→P.283), the pre-collision brake assist and pre-collision braking functions are also disabled.
- The PCS warning light will turn on and “VSC Turned Off Pre-Collision Brake System Unavailable” will be displayed on the multi-information display.

## LTA (Lane Tracing Assist) \*

\*: If equipped

**While driving on a road with clear white (yellow) lane lines, the LTA system warns the driver if the vehicle may deviate from the current lane or course\*, and also can slightly operate the steering wheel to help avoid deviation from the lane or course\*. Also, while the dynamic radar cruise control with full-speed range (→P.234) is operating, this system will operate the steering wheel to maintain the vehicle's lane position.**

**The LTA system recognizes white (yellow) lane lines or a course\* using the front camera. Additionally, it detects preceding vehicles using the front camera and radar.**

\*: Boundary between asphalt and the side of the road, such as grass, soil, or a curb

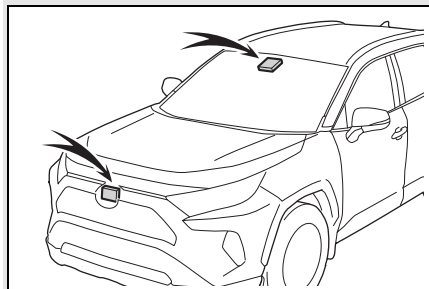

**WARNING****■ Before using LTA system**

- Do not rely solely upon the LTA system. The LTA system does not automatically drive the vehicle or reduce the amount of attention that must be paid to the area in front of the vehicle. The driver must always assume full responsibility for driving safely by paying careful attention to the surrounding conditions and operating the steering wheel to correct the path of the vehicle. Also, the driver must take adequate breaks when fatigued, such as from driving for a long period of time.
- Failure to perform appropriate driving operations and pay careful attention may lead to an accident, resulting in death or serious injury.

**■ Situations unsuitable for LTA system**

In the following situations, use the LTA switch to turn the system off. Failure to do so may lead to an accident, resulting in death or serious injury.

- Vehicle is driven on a road surface which is slippery due to rainy weather, fallen snow, freezing, etc.
- Vehicle is driven on a snow-covered road.
- White (yellow) lines are difficult to see due to rain, snow, fog, dust, etc.
- Vehicle is driven in a temporary lane or restricted lane due to construction work.
- Vehicle is driven in a construction zone.
- A spare tire, tire chains, etc. are equipped.

- When the tires have been excessively worn, or when the tire inflation pressure is low.

- When your vehicle is towing a trailer\* or during emergency towing

\*: Vehicles that can tow a trailer.  
(→P.170)

**■ Preventing LTA system malfunctions and operations performed by mistake**

- Do not modify the headlights or place stickers, etc. on the surface of the lights.
- Do not modify the suspension etc. If the suspension etc. needs to be replaced, contact your Toyota dealer.
- Do not install or place anything on the hood or grille. Also, do not install a grille guard (bull bars, kangaroo bar, etc.).
- If your windshield needs repairs, contact your Toyota dealer.

**■ Conditions in which functions may not operate properly**

In the following situations, the functions may not operate properly and the vehicle may depart from its lane. Drive safely by always paying careful attention to your surroundings and operate the steering wheel to correct the path of the vehicle without relying solely on the functions.

**WARNING**

- When the follow-up cruising display is displayed (→P.226) and the preceding vehicle changes lanes. (Your vehicle may follow the preceding vehicle and also change lanes.)

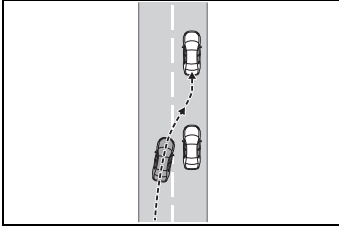

- When the follow-up cruising display is displayed (→P.226) and the preceding vehicle is swaying. (Your vehicle may sway accordingly and depart from the lane.)
- When the follow-up cruising display is displayed (→P.226) and the preceding vehicle departs from its lane. (Your vehicle may follow the preceding vehicle and depart from the lane.)
- When the follow-up cruising display is displayed (→P.226) and the preceding vehicle is being driven extremely close to the left/right lane line. (Your vehicle may follow the preceding vehicle and depart from the lane.)
- Vehicle is being driven around a sharp curve.

- Objects or patterns that could be mistaken for white (yellow) lines are present on the side of the road (guardrails, reflective poles, etc.).

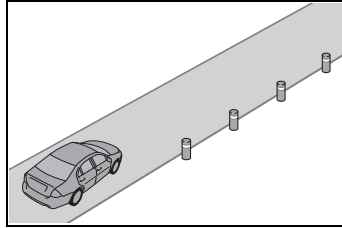

- Vehicle is driven where the road diverges, merges, etc.

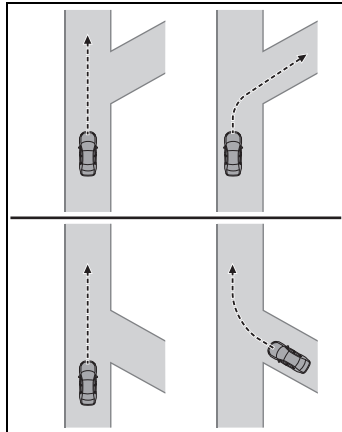

- Repair marks of asphalt, white (yellow) lines, etc. are present due to road repair.

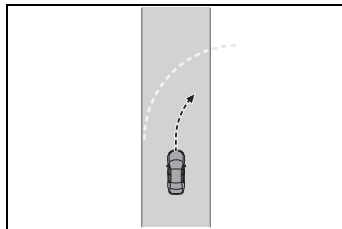

- There are shadows on the road that run parallel with, or cover, the white (yellow) lines.



**WARNING**

- The vehicle is driven in an area without white (yellow) lines, such as in front of a tollgate or checkpoint, or at an intersection, etc.
- The white (yellow) lines are cracked, "Raised pavement marker" or stones are present.
- The white (yellow) lines cannot be seen or are difficult to see due to sand, etc.
- The vehicle is driven on a road surface that is wet due to rain, puddles, etc.
- The traffic lines are yellow (which may be more difficult to recognize than lines that are white).
- The white (yellow) lines cross over a curb, etc.
- The vehicle is driven on a bright surface, such as concrete.
- If the edge of the road is not clear or straight.
- The vehicle is driven on a surface that is bright due to reflected light, etc.
- The vehicle is driven in an area where the brightness changes suddenly, such as at the entrances and exits of tunnels, etc.
- Light from the headlights of an oncoming vehicle, the sun, etc. enters the camera.
- The vehicle is driven on a slope.
- The vehicle is driven on a road which tilts left or right, or a winding road.
- The vehicle is driven on an unpaved or rough road.
- The traffic lane is excessively narrow or wide.

- The vehicle is extremely tilted due to carrying heavy luggage or having improper tire pressure.
- The distance to the preceding vehicle is extremely short.
- The vehicle is moving up and down a large amount due to road conditions during driving (poor roads or road seams).
- When driving in a tunnel or at night with the headlights off or when a headlight is dim due to its lens being dirty or it being misaligned.
- The vehicle is struck by a cross-wind.
- The vehicle is affected by wind from a vehicle driven in a nearby lane.
- The vehicle has just changed lanes or crossed an intersection.
- Tires which differ by structure, manufacturer, brand or tread pattern are used.
- When tires of a size other than specified are installed.
- Snow tires, etc. are equipped.
- The vehicle is being driven at extremely high speeds.

### Functions included in LTA system

#### ■ Lane departure alert function

When the system determines that the vehicle might depart from its lane or course\*, a warning is displayed on the multi-information display, and a warning buzzer will sound to alert the driver.

When the warning buzzer sounds, check the area around your vehicle and

carefully operate the steering wheel to move the vehicle back to the center of the lane.

Vehicles with BSM: When the system determines that the vehicle might depart from its lane and that the possibility of a collision with an overtaking vehicle in the adjacent lane is high, the lane departure alert will operate even if the turn signals are operating.

\*: Boundary between asphalt and the side of the road, such as grass, soil, or a curb

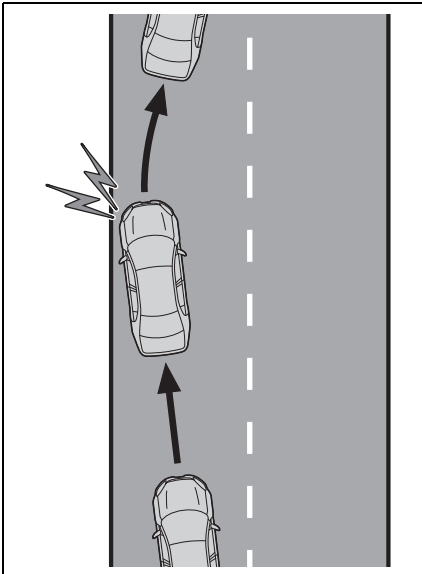

#### ■ Steering assist function

When the system determines that the vehicle might depart from its lane or course<sup>\*</sup>, the system provides assistance as necessary by operating the steering wheel in small amounts for a short period of time to keep the vehicle in its lane.

Vehicles with BSM: When the system determines that the vehicle might

depart from its lane and that the possibility of a collision with an overtaking vehicle in the adjacent lane is high, the steering assist function will operate even if the turn signals are operating.

\*: Boundary between asphalt and the side of the road, such as grass, soil, or a curb

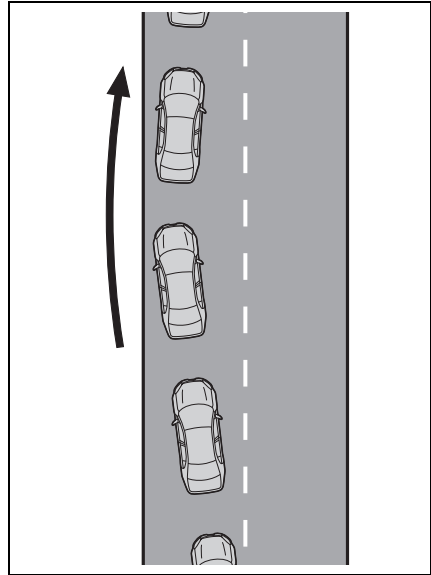

#### ■ Vehicle sway warning function

When the vehicle is swaying within a lane, the warning buzzer will sound and a message will be displayed on the multi-information display to alert the driver.

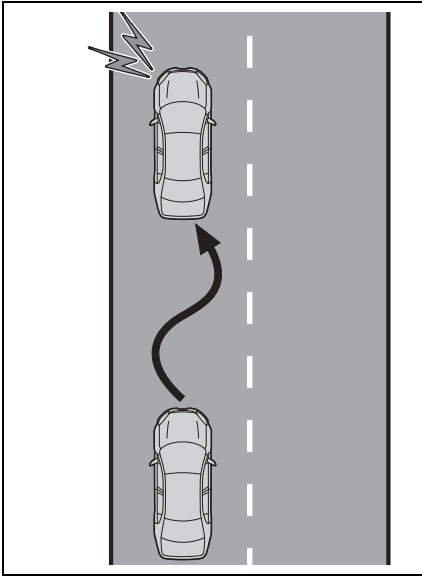

### ■ Lane centering function

This function is linked with dynamic radar cruise control with full-speed range and provides the required assistance by operating the steering wheel to keep the vehicle in its current lane.

When dynamic radar cruise control with full-speed range is not operating, the lane centering function does not operate.

In situations where the white (yellow) lane lines are difficult to see or are not visible, such as when in a traffic jam, this function will operate to help follow a preceding vehicle by monitoring the position of the preceding vehicle.

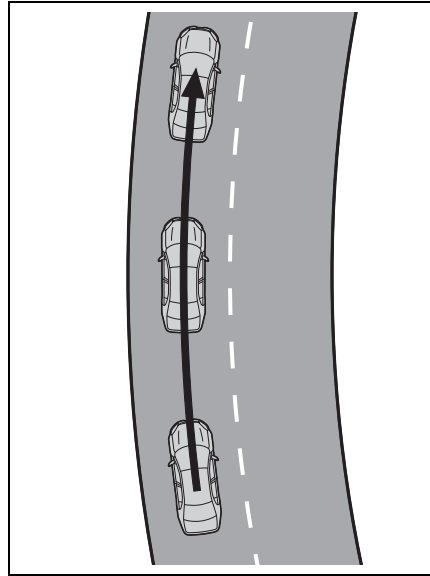

### ■ LTA system setting

#### ■ Turning the lane centering function ON/OFF

Press the LTA switch.

The lane centering function will change between ON/OFF each time the switch is pressed.

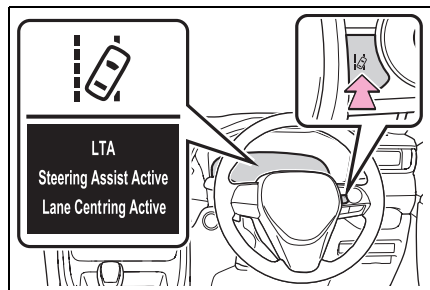

Lane centering function on: "LTA Steering Assist Active Lane Centring Active" is displayed.

When the LTA system is turned on, operation of the LTA system continues in the same condition the next time the

hybrid system is started.

### ■ Turning the LTA system OFF

Press and hold the LTA switch

The LTA indicator light turns off when the LTA is turned OFF.

Press the switch again to turn the system on.

The LTA is turned ON each time the power switch is turned to ON.

However, the lane centering function keeps either the ON/OFF state prior to the power switch being turned OFF.

## Indications on multi-information display

### ▶ Vehicles with 7-inch display

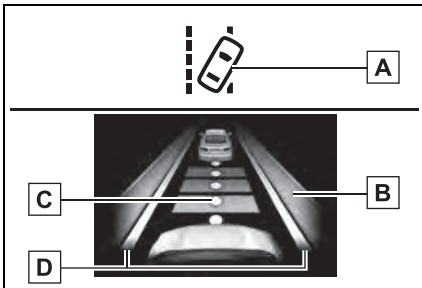

#### A LTA indicator

The illumination condition of the indicator informs the driver of the system operation status.

Illuminated in white: LTA system is operating.

Illuminated in green: Steering wheel assistance of the steering assist function or lane centering function is operating.

Flashing in orange: Lane departure alert function is operating.

#### B Operation display of steering

#### wheel operation support

Displayed when the multi-information display is switched to the driving support system information display.

Indicates that steering wheel assistance of the steering assist function or lane centering function is operating.

Both outer sides of the lane are displayed: Indicates that steering wheel assist of the lane centering function is operating.

One outer side of the lane is displayed: Indicates that steering wheel assist of the steering assist function is operating.

Both outer sides of the lane are flashing: Alerts the driver that their input is necessary to stay in the center of the lane (lane centering function).

#### C Follow-up cruising display

Displayed when the multi-information display is switched to the driving support system information display.

Indicates that steering assist of the lane centering function is operating by monitoring the position of a preceding vehicle.

When the follow-up cruising display is displayed, if the preceding vehicle moves, your vehicle may move in the same way. Always pay careful attention to your surroundings and operate the steering wheel as necessary to correct the path of the vehicle and ensure safety.

#### D Lane departure alert function display

Displayed when the multi-information display is switched to the driving support system information display.

- Inside of displayed lines is white



Indicates that the system is recognizing white (yellow) lines or a course\*. When the vehicle departs from its lane, the white line displayed on the side the vehicle departs from flashes orange.

- Inside of displayed lines is black



Indicates that the system is not able to recognize white (yellow) lines or a course\* or is temporarily canceled.

\*: Boundary between asphalt and the side of the road, such as grass, soil, or a curb

- ▶ Vehicles with 12.3-inch display

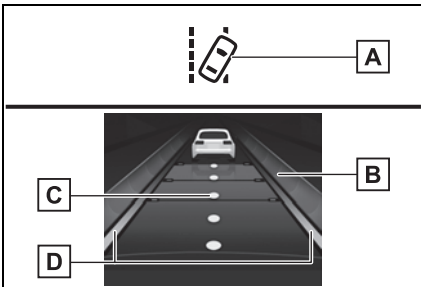

#### A LTA indicator

The illumination condition of the indicator informs the driver of the system operation status.

Illuminated in white: LTA system is operating.

Illuminated in green: Steering wheel assistance of the steering assist function or lane centering function is operating.

Flashing in orange: Lane departure alert function is operating.

#### B Operation display of steering wheel operation support

Displayed when the multi-information display is switched to the driving support system information display.

Indicates that steering wheel assistance of the steering assist function or lane centering function is operating.

Both outer sides of the lane are displayed: Indicates that steering wheel assist of the lane centering function is operating.

One outer side of the lane is displayed: Indicates that steering wheel assist of the steering assist function is operating.

Both outer sides of the lane are flashing: Alerts the driver that their input is necessary to stay in the center of the lane (lane centering function).

#### C Follow-up cruising display

Displayed when the multi-information display is switched to the driving support system information display.

Indicates that steering assist of the lane centering function is operating by monitoring the position of a preceding vehicle.

When the follow-up cruising display is

displayed, if the preceding vehicle moves, your vehicle may move in the same way. Always pay careful attention to your surroundings and operate the steering wheel as necessary to correct the path of the vehicle and ensure safety.

#### **D** Lane departure alert function display

Displayed when the multi-information display is switched to the driving support system information display.

- Inside of displayed lines is white

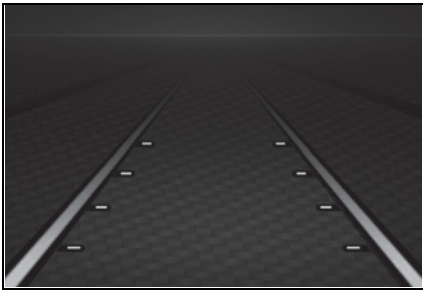

Indicates that the system is recognizing white (yellow) lines or a course\*. When the vehicle departs from its lane, the white line displayed on the side the vehicle departs from flashes orange.

- Inside of displayed lines is black

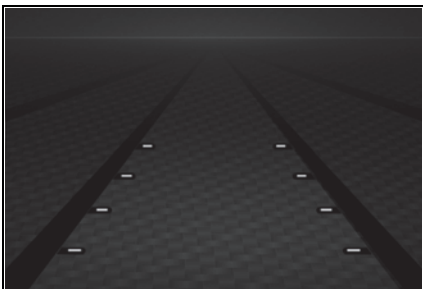

Indicates that the system is not able to recognize white (yellow) lines or a course\* or is temporarily canceled.

- \*: Boundary between asphalt and the side of the road, such as grass, soil, or a curb

#### ■ Operation conditions of each function

- Lane departure alert function

This function operates when all of the following conditions are met.

- LTA is turned on.
- Vehicle speed is approximately 50 km/h (32 mph) or more.\*<sup>1</sup>
- System recognizes white (yellow) lane lines or a course\*<sup>2</sup>. (When a white [yellow] line or course\*<sup>2</sup> is recognized on only one side, the system will operate only for the recognized side.)
- Width of traffic lane is approximately 3 m (9.8 ft.) or more.
- Turn signal lever is not operated. (Vehicles with BSM: Except when another vehicle is in the lane on the side where the turn signal was operated)
- Vehicle is not being driven around a sharp curve.
- No system malfunctions are detected. (→P.230)

\*<sup>1</sup>: The function operates even if the vehicle speed is less than approximately 50 km/h (32 mph) when the lane centering function is operating.

\*<sup>2</sup>: Boundary between asphalt and the side of the road, such as grass, soil, or a curb

- Steering assist function

This function operates when all of the following conditions are met in addition to the operation conditions for the lane departure alert function.

- Vehicle is not accelerated or decelerated by a fixed amount or more.
- Steering wheel is not operated with a steering force level suitable for changing lanes.
- ABS, VSC, TRC and PCS are not

operating.

- TRC or VSC is not turned off.
- Hands off steering wheel warning is not displayed. (→P.229)

#### ● Vehicle sway warning function

This function operates when all of the following conditions are met.

- Setting for “Sway Warning” in the  screen of the multi-information display is set to “ON”. (→P.88, 98)
- Vehicle speed is approximately 50 km/h (32 mph) or more.
- Width of traffic lane is approximately 3 m (9.8 ft.) or more.
- No system malfunctions are detected. (→P.230)

#### ● Lane centering function

This function operates when all of the following conditions are met.

- LTA is turned on.
- Setting for “Lane Centre” in the  screen of the multi-information display is set to “ON”. (→P.88, 98)
- This function recognizes white (yellow) lane lines or the position of a preceding vehicle (except when the preceding vehicle is small, such as a motorcycle).
- The dynamic radar cruise control with full-speed range is operating in vehicle-to-vehicle distance control mode.
- Width of traffic lane is approximately 3 to 4 m (10 to 13 ft.).
- Turn signal lever is not operated.
- Vehicle is not being driven around a sharp curve.
- No system malfunctions are detected. (→P.230)
- Vehicle does not accelerate or decelerate by a fixed amount or more.
- Steering wheel is not operated with a steering force level suitable for changing lanes.
- ABS, VSC, TRC and PCS are not operating.
- TRC or VSC is not turned off.
- Hands off steering wheel warning is not displayed. (→P.229)

- The vehicle is being driven in the center of a lane.
- Steering assist function is not operating.

#### ■ Temporary cancelation of functions

- When operation conditions are no longer met, a function may be temporarily canceled. However, when the operation conditions are met again, operation of the function is automatically restored. (→P.228)

- If the operation conditions (→P.228) are no longer met while the lane centering function is operating, the buzzer may sound to indicate that the function has been temporarily canceled.

#### ■ Steering assist function/lane centering function

- Depending on the vehicle speed, lane departure situation, road conditions, etc., the driver may not feel the function is operating or the function may not operate at all.

- The steering control of the function is overridden by the driver’s steering wheel operation.

- Do not attempt to test the operation of the steering assist function.

#### ■ Lane departure alert function

- The warning buzzer may be difficult to hear due to external noise, audio playback, etc.

- If the edge of the course\* is not clear or straight, the lane departure alert function may not operate.

- Vehicles with BSM: It may not be possible for the system to determine if there is a danger of a collision with a vehicle in an adjacent lane.

- Do not attempt to test the operation of the lane departure alert function.

\*: Boundary between asphalt and the side of the road, such as grass, soil, or a curb

#### ■ Hands off steering wheel warning

In the following situations, a warning

message urging the driver to hold the steering wheel and the symbol shown in the illustration are displayed on the multi-information display to warn the driver. The warning stops when the system determines that the driver holds the steering wheel. Always keep your hands on the steering wheel when using this system, regardless of warnings.



- When the system determines that the driver is driving without holding the steering wheel while the system is operating

If the driver continues to keep their hands off of the steering wheel, the buzzer sounds, the driver is warned and the function is temporarily canceled. This warning also operates in the same way when the driver continuously operates the steering wheel only a small amount.

- When the system determines that the vehicle may deviate from the lane while driving around a curve while the lane centering function is operating.

Depending on the vehicle condition and road conditions, the warning may not operate. Also, if the system determines that the vehicle is driving around a curve, warnings will occur earlier than during straight-lane driving.

- When the system determines that the driver is driving without holding the steering wheel while the steering wheel assist of the steering assist function is operating.

If the driver continues to keep their hands off of the steering wheel and the

steering wheel assist is operating, the buzzer sounds and the driver is warned. Each time the buzzer sounds, the continuing time of the buzzer becomes longer.

#### ■ Vehicle sway warning function

When the system determines that the vehicle is swaying while the vehicle sway warning function is operating, a buzzer sounds and a warning message urging the driver to rest and the symbol shown in the illustration are simultaneously displayed on the multi-information display.



Depending on the vehicle and road conditions, the warning may not operate.

#### ■ Warning message

If the following warning message is displayed on the multi-information display and the LTA indicator illuminates in orange, follow the appropriate troubleshooting procedure. Also, if a different warning message is displayed, follow the instructions displayed on the screen.

- “LTA Malfunction Visit Your Dealer”

The system may not be operating properly. Have the vehicle inspected by your Toyota dealer.

- “LTA Unavailable”

The system is temporarily canceled due to a malfunction in a sensor other than the front camera. Turn the LTA system off, wait for a little while, and then turn the LTA system back on.

- “LTA Unavailable at Current Speed”

The function cannot be used as the vehicle speed exceeds the LTA opera-



tion range. Drive slower.

### ■ Customization

Function settings can be changed.  
(→P.94, 103)

## RSA (Road Sign Assist)\*

\*: If equipped

The RSA system recognizes specific road signs using the front camera to provide information to the driver via the display.

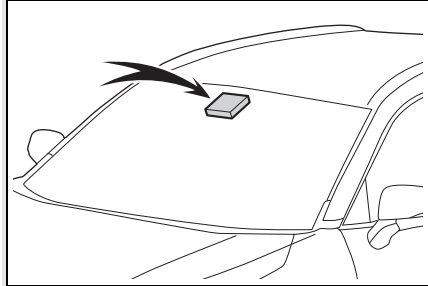

If the system judges that the vehicle is being driven over the speed limit, according to the recognized road signs, it notifies the driver through a visual notification and notification buzzer.



### WARNING

#### ■ Before using the RSA

Do not rely solely upon the RSA system. RSA is a system which supports the driver by providing information, but it is not a replacement for a driver's own vision and awareness. Drive safely by always paying careful attention to the traffic rules.

### Indication on the multi-information display

When the front camera recognizes a sign, the sign will be displayed on

the multi-information display.

- Vehicles with 7-inch display:  
When the driving support system information display is selected, a maximum of 2 signs can be displayed. (→P.88)  
Vehicles with 12.3-inch display:  
A maximum of 2 signs can be displayed. (→P.98)

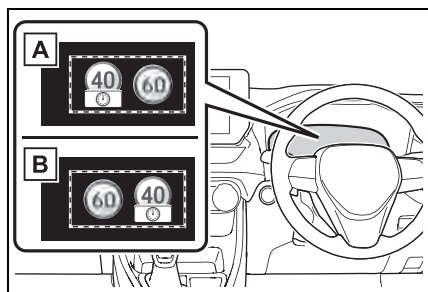

- A** Vehicles with 7-inch display
- B** Vehicles with 12.3-inch display

- Vehicles with 7-inch display:  
When a tab other than the driving support system information display is selected, the following types of road signs will be displayed. (→P.88)
- Speed limit sign

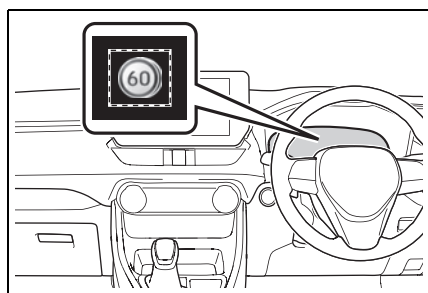

If signs other than speed limit signs are recognized, they will be displayed in an

overlapping stack under the current speed limit sign.

### Supported types of road signs

The following types of road signs, including electronic signs and blinking signs, are displayed.

A non-official or a recently introduced traffic sign may not be displayed.



Speed limit\*



Conditional speed limit sign (School zone)

\*: No speed limit information  is displayed when speed limit sign information is not available.

### Notification function

In the following situations, the RSA system will notify the driver.

- When the vehicle speed exceeds the speed notification threshold of the speed limit sign displayed, the sign display will be emphasized and a buzzer will sound.

Depending on the situation, a notification function may not operate properly.

### Setting procedure

→P.94, 103

### ■ Automatic turn-off of RSA sign display

In the following situations, a displayed speed limit sign will stop being displayed automatically:

- No sign has been recognized for a certain distance.
- The road changes due to a left or right turn, etc.

### ■ Conditions in which the function may not operate or detect correctly

In the following situations, RSA does not operate normally and may not recognize signs, display the incorrect sign, etc. However, this does not indicate a malfunction.

- The front camera is misaligned due to a strong impact being applied to the sensor, etc.
- Dirt, snow, stickers, etc. are on the windshield near the front camera.
- In inclement weather such as heavy rain, fog, snow or sand storms.
- Light from an oncoming vehicle, the sun, etc. enters the front camera.
- The sign is dirty, faded, tilted or bent.
- The contrast of electronic sign is low.
- All or part of the sign is hidden by the leaves of a tree, a pole, etc.
- The sign is only visible to the front camera for a short amount of time.
- The driving scene (turning, lane change, etc.) is judged incorrectly.
- If a sign not appropriate for the currently traveled lane, but the sign exists directly after a freeway branches, or in an adjacent lane just before merging.
- Stickers are attached to the rear of the preceding vehicle.
- A sign resembling a system compatible sign is recognized.
- Side road speed signs may be detected and displayed (if positioned in sight of the front camera) while the vehicle is traveling on the main road.

- Roundabout exit road speed signs may be detected and displayed (if positioned in sight of the front camera) while traveling on a roundabout.
- The front of the vehicle is raised or lowered due to the carried load.
- The surrounding brightness is not sufficient or changes suddenly.
- When a sign intended for trucks, etc. is recognized.
- The speed information displayed on the meter and on the navigation system may be different due to the navigation system using map data.

### ■ Speed limit sign display

If the power switch was last turned off while a speed limit sign was displayed on the multi-information display, the same sign displays again when the power switch is turned to ON.

### ■ If “RSA Malfunction Visit Your Dealer” is shown

The system may be malfunctioning. Have the vehicle inspected by your Toyota dealer.

### ■ Customization

Some functions can be customized. (→P.94, 103)

## Dynamic radar cruise control with full-speed range\*

\*: If equipped

In vehicle-to-vehicle distance control mode, the vehicle automatically accelerates, decelerates and stops to match the speed changes of the preceding vehicle even if the accelerator pedal is not depressed. In constant speed control mode, the vehicle runs at a fixed speed.

Use the dynamic radar cruise control with full-speed range on freeways and highways.

- Vehicle-to-vehicle distance control mode (→P.237)
- Constant speed control mode (→P.242)

## System components

### ■ Meter display

- ▶ Vehicles with 7-inch multi-information display

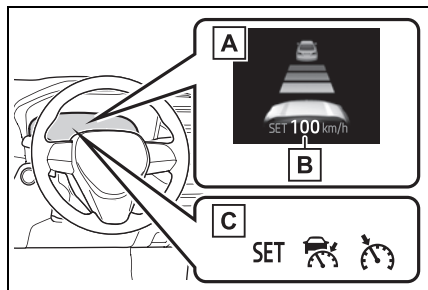

- A** Multi-information display
- B** Set speed
- C** Indicators

- ▶ Vehicles with 12.3-inch multi-information display

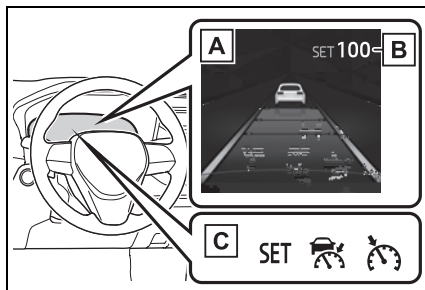

- A** Multi-information display
- B** Set speed
- C** Indicators

### ■ Operation switches

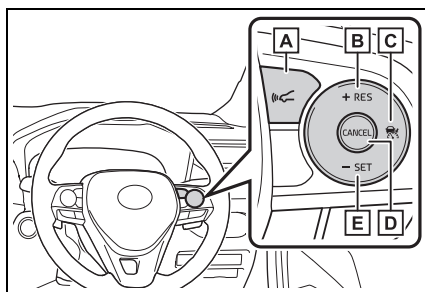

- A** Vehicle-to-vehicle distance switch
- B** “+RES” switch
- C** Cruise control main switch
- D** Cancel switch
- E** “-SET” switch

**WARNING****■ Before using dynamic radar cruise control with full-speed range**

- Driving safely is the sole responsibility of the driver. Do not rely solely on the system, and drive safely by always paying careful attention to your surroundings.
- The dynamic radar cruise control with full-speed range provides driving assistance to reduce the driver's burden. However, there are limitations to the assistance provided.

Read the following conditions carefully. Do not overly rely on this system and always drive carefully.

- When the sensor may not be correctly detecting the vehicle ahead: →P.244
- Conditions under which the vehicle-to-vehicle distance control mode may not function correctly: →P.245
- Set the speed appropriately depending on the speed limit, traffic flow, road conditions, weather conditions, etc. The driver is responsible for checking the set speed.
- Even when the system is functioning normally, the condition of the preceding vehicle as detected by the system may differ from the condition observed by the driver. Therefore, the driver must always remain alert, assess the danger of each situation and drive safely. Relying solely on this system or assuming the system ensures safety while driving can lead to an accident, resulting in death or serious injury.
- Switch the dynamic radar cruise control with full-speed range setting to off, using the cruise control main switch when not in use.

**■ Cautions regarding the driving assist systems**

Observe the following precautions, as there are limitations to the assistance provided by the system. Failure to do so may cause an accident resulting in death or serious injury.

- Assisting the driver to measure following distance

The dynamic radar cruise control with full-speed range is only intended to help the driver in determining the following distance between the driver's own vehicle and a designated vehicle traveling ahead. It is not a mechanism that allows careless or inattentive driving, and it is not a system that can assist the driver in low-visibility conditions.

It is still necessary for driver to pay close attention to the vehicle's surroundings.

- Assisting the driver to judge proper following distance

The dynamic radar cruise control with full-speed range determines whether the following distance between the driver's own vehicle and a designated vehicle traveling ahead is within a set range. It is not capable of making any other type of judgement. Therefore, it is absolutely necessary for the driver to remain vigilant and to determine whether or not there is a possibility of danger in any given situation.

**WARNING**

- Assisting the driver to operate the vehicle

The dynamic radar cruise control with full-speed range does not include functions which will prevent or avoid collisions with vehicles ahead of your vehicle. Therefore, if there is ever any possibility of danger, the driver must take immediate and direct control of the vehicle and act appropriately in order to ensure the safety of all involved.

**■ Situations unsuitable for dynamic radar cruise control with full-speed range**

Do not use dynamic radar cruise control with full-speed range in any of the following situations. Doing so may result in inappropriate speed control and could cause an accident resulting in death or serious injury.

- Roads where there are pedestrians, cyclists, etc.
- In heavy traffic
- On roads with sharp bends
- On winding roads
- On slippery roads, such as those covered with rain, ice or snow
- On steep downhill, or where there are sudden changes between sharp up and down gradients

Vehicle speed may exceed the set speed when driving down a steep hill.

- At entrances to freeways and highways
- When weather conditions are bad enough that they may prevent the sensors from detecting correctly (fog, snow, sandstorm, heavy rain, etc.)

- When there is rain, snow, etc. on the front surface of the radar or front camera
- In traffic conditions that require frequent repeated acceleration and deceleration
- When your vehicle is towing a trailer\* or during emergency towing  
\*: Vehicles that can tow a trailer.  
(→P.170)
- When an approach warning buzzer is heard often

## Driving in vehicle-to-vehicle distance control mode

This mode employs a radar to detect the presence of vehicles up to approximately 100 m (328 ft.) ahead, determines the current vehicle-to-vehicle following distance, and operates to maintain a suitable following distance from the vehicle ahead. The desired vehicle-to-vehicle distance can also be set by operating the vehicle-to-vehicle distance switch.

When driving on downhill slopes, the vehicle-to-vehicle distance may become shorter.

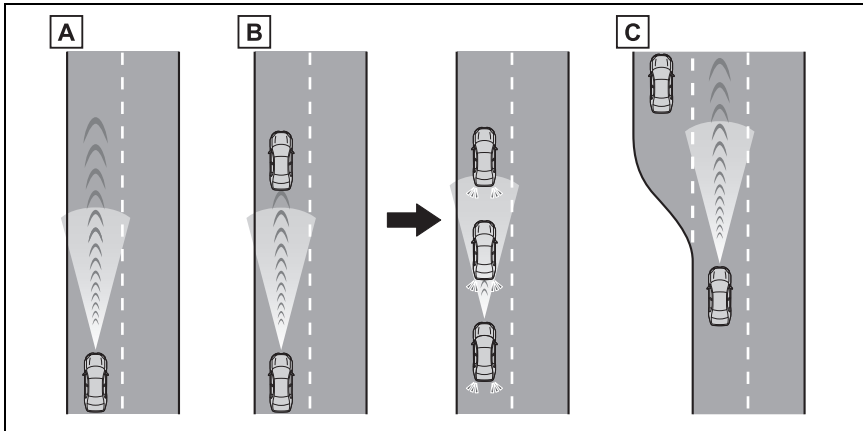

### **A** Example of constant speed cruising

When there are no vehicles ahead

The vehicle travels at the speed set by the driver.

### **B** Example of deceleration cruising and follow-up cruising

When a preceding vehicle driving slower than the set speed appears

When a vehicle is detected running ahead of you, the system automatically decelerates your vehicle. When a greater reduction in vehicle speed is necessary, the system applies the brakes (the stop lights will come on at this time). The system will respond to changes in the speed of the vehicle ahead in order to maintain the vehicle-to-vehicle distance set by the driver. Approach warning warns you when the system cannot decelerate sufficiently to prevent your vehicle from closing in on the vehicle ahead.

When the vehicle ahead of you stops, your vehicle will also stop (vehicle is stopped by system control). After the vehicle ahead starts off, pressing the “+RES” switch or depressing the accelerator pedal (start-off operation) will resume follow-up cruising. If the start-off operation is not performed, system control continues to keep your vehicle stopped.

When the turn signal lever is operated and your vehicle moves to an overtaking lane while driving at 80 km/h (50 mph) or more, the vehicle will accelerate to help to overtake a passing vehicle.

The system's identification of what is an overtaking lane may be determined solely based on the location of the steering wheel in the vehicle (left side driver position versus right side driver position.) If the vehicle is driven to a region where the overtaking lane is on a different side from where the vehicle is normally driven, the vehicle may accelerate when the turn signal lever is operated in the opposite direction to the overtaking lane (e.g., if the driver normally operates the vehicle in a region where the overtaking lane is to the right but then drives to a region where the overtaking lane is to the left, the vehicle may accelerate when the right turn signal is activated).

### **C** Example of acceleration

When there are no longer any preceding vehicles driving slower than the set speed

The system accelerates until the set speed is reached. The system then returns to constant speed cruising.

## Setting the vehicle speed (vehicle-to-vehicle distance control mode)

- 1 Press the cruise control main switch to activate the cruise control.

Dynamic radar cruise control indicator will come on and a message will be displayed on the multi-information display. Press the switch again to deactivate the cruise control.

If the cruise control main switch is pressed and held for 1.5 seconds or more, the system turns on in constant

speed control mode. (→P.242)

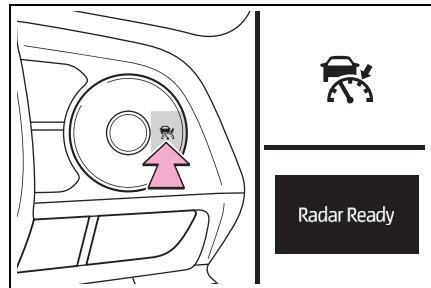

- 2 Accelerate or decelerate, with accelerator pedal operation, to the desired vehicle speed (at or above approximately 30 km/h [20 mph]) and press the “-SET” switch to set the speed.

Cruise control “SET” indicator will come on.

The vehicle speed at the moment the switch is released becomes the set speed.



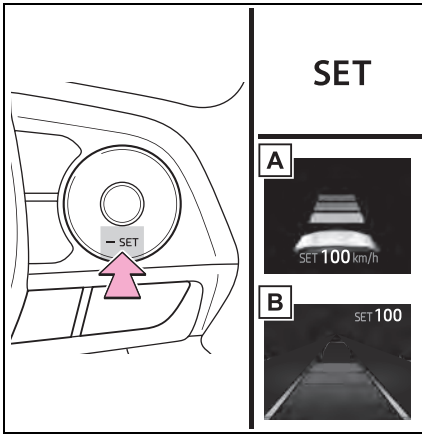

- A** Vehicles with 7-inch multi-information display
- B** Vehicles with 12.3-inch multi-information display

### Adjusting the set speed

- Adjusting the set speed by the switch

To change the set speed, press the “+RES” or “-SET” switch until the desired set speed is displayed.

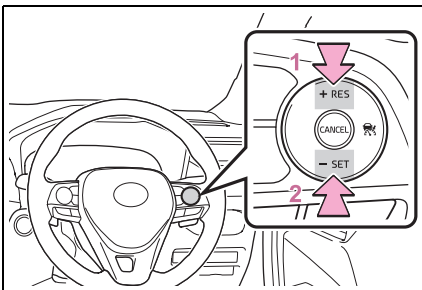

- 1** Increases the speed (Except when the vehicle has been stopped by system control in vehicle-to-vehicle distance control mode)

- 2** Decreases the speed

Fine adjustment: Press the switch.

Large adjustment: Press and hold the switch to change the speed, and release when the desired speed is reached.

In the vehicle-to-vehicle distance control mode, the set speed will be increased or decreased as follows:

Fine adjustment: By 1 km/h (0.6 mph)<sup>\*1</sup> or 1 mph (1.6 km/h)<sup>\*2</sup> each time the switch is pressed

Large adjustment: Increases or decreases in 5 km/h (3.1 mph)<sup>\*1</sup> or 5 mph (8 km/h)<sup>\*2</sup> increments for as long as the switch is held

In the constant speed control mode (→P.242), the set speed will be increased or decreased as follows:

Fine adjustment: By 1 km/h (0.6 mph)<sup>\*1</sup> or 1 mph (1.6 km/h)<sup>\*2</sup> each time the switch is pressed

Large adjustment: The speed will continue to change while the switch is held.

<sup>\*1</sup>: When the set speed is shown in “km/h”

<sup>\*2</sup>: When the set speed is shown in “MPH”

- Increasing the set speed by the accelerator pedal

- 1** Accelerate with accelerator pedal operation to the desired vehicle speed
- 2** Press the “-SET” switch

### Changing the vehicle-to-vehicle distance (vehicle-to-vehicle distance control mode)

Pressing the switch changes the vehicle-to-vehicle distance as follows:

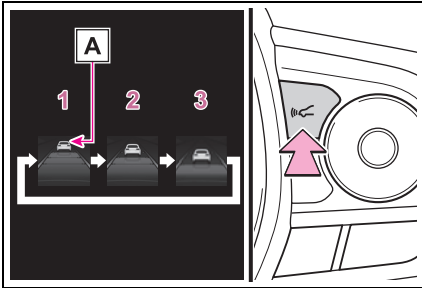

- 1 Long
- 2 Medium
- 3 Short

If a vehicle is running ahead of you, the preceding vehicle mark **A** will also be displayed.

### Vehicle-to-vehicle distance settings (vehicle-to-vehicle distance control mode)

Select a distance from the table below. Note that the distances shown correspond to a vehicle speed of 80 km/h (50 mph). Vehicle-to-vehicle distance increases/decreases in accordance with vehicle speed. When the vehicle is stopped by system control, the vehicle stops at a certain vehicle-to-vehicle distance

depending on the situation.

Distance options	Vehicle-to-vehicle distance
Long	Approximately 50 m (160 ft.)
Medium	Approximately 40 m (130 ft.)
Short	Approximately 30 m (100 ft.)

### Resuming follow-up cruising when the vehicle has been stopped by system control (vehicle-to-vehicle distance control mode)

After the vehicle ahead of you starts off, press the “+RES” switch. Your vehicle will also resume follow-up cruising if the accelerator pedal is depressed after the vehicle ahead of you starts off.

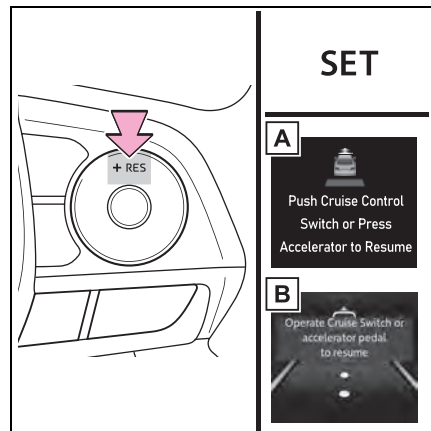

- A** Vehicles with 7-inch multi-information display

- B** Vehicles with 12.3-inch multi-information display

### Canceling and resuming the speed control

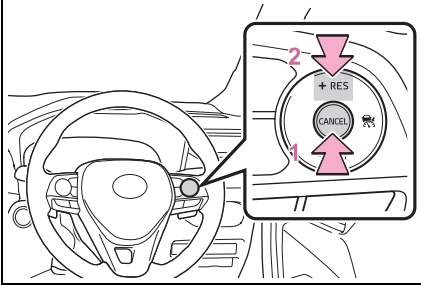

- 1** Pressing the cancel switch cancels the speed control.

The speed control is also canceled when the brake pedal is depressed. (When the vehicle has been stopped by system control, depressing the brake pedal does not cancel the setting.)

- 2** Pressing the “+RES” switch resumes the cruise control and returns vehicle speed to the set speed.

### Approach warning (vehicle-to-vehicle distance control mode)

When your vehicle is too close to a vehicle ahead, and sufficient automatic deceleration via the cruise control is not possible, the display will flash and the buzzer will sound to alert the driver. An example of this would be if another driver cuts in front of you while you are following a vehicle. Depress the brake

pedal to ensure an appropriate vehicle-to-vehicle distance.

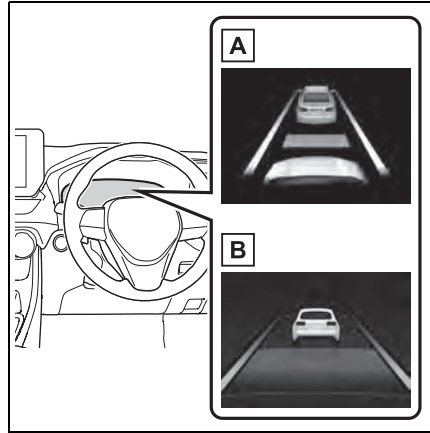

- A** Vehicles with 7-inch multi-information display

- B** Vehicles with 12.3-inch multi-information display

### ■ Warnings may not occur when

In the following instances, warnings may not occur even when the vehicle-to-vehicle distance is small.

- When the speed of the preceding vehicle matches or exceeds your vehicle speed
- When the preceding vehicle is traveling at an extremely slow speed
- Immediately after the cruise control speed was set
- When depressing the accelerator pedal

## Selecting constant speed control mode

When constant speed control mode is selected, your vehicle will maintain a set speed without controlling the vehicle-to-vehicle distance. Select this mode only when vehicle-to-vehicle distance control mode does not function correctly due to a dirty radar, etc.

- 1 With the cruise control off, press and hold the cruise control main switch for 1.5 seconds or more.

Immediately after the switch is pressed, the dynamic radar cruise control indicator will come on. Afterwards, it switches to the cruise control indicator.

Switching to constant speed control mode is only possible when operating the switch with the cruise control off.

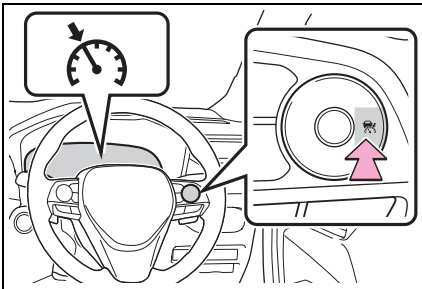

- 2 Accelerate or decelerate, with accelerator pedal operation, to the desired vehicle speed (at or above approximately 30 km/h [20 mph]) and press the “-SET” switch to set the speed.

Cruise control “SET” indicator will come on.

The vehicle speed at the moment the switch is released becomes the set speed.

Adjusting the speed setting: →P.239

Canceling and resuming the speed setting: →P.241

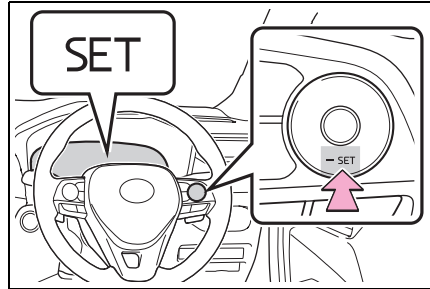

## Dynamic Radar Cruise Control with Road Sign Assist (vehicles with RSA)

When this function is enabled and the system is operating in vehicle-to-vehicle distance control mode (→P.237), when a speed limit sign is detected, the recognized speed limit will be displayed with an up/down arrow. The set speed can be increased/reduced to the recognized speed limit by pressing and holding the “+RES”/“-SET” switch.

- When the current set speed is lower than the recognized speed limit

Press and hold the “+RES” switch.

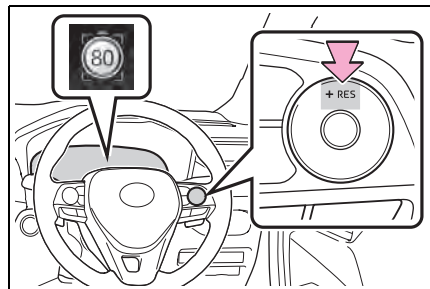

- When the current set speed is higher than the recognized speed limit

Press and hold the “-SET” switch.

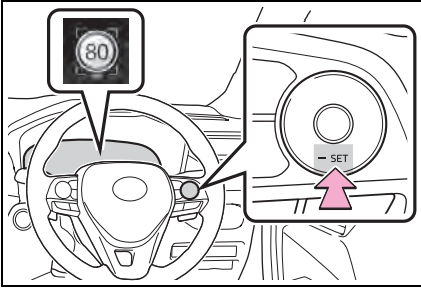

### Enabling/Disabling the Dynamic Radar Cruise Control with Road Sign Assist (vehicles with RSA)

Dynamic Radar Cruise Control with Road Sign Assist can be enabled/disabled in the  screen on the multi-information display. (→P.94, 103)

When the Dynamic Radar Cruise Control with Road Sign Assist is operating, while driving down a hill, the vehicle speed may exceed the set speed.

In this case, the displayed set vehicle speed will be highlighted and a buzzer will sound to alert the driver.

#### ■ Dynamic radar cruise control with full-speed range can be set when

- The shift lever is in D.
- The desired set speed can be set when the vehicle speed is approximately 30 km/h (20 mph) or more. (However, when the vehicle speed is

set while driving at below approximately 30 km/h [20 mph], the set speed will be set to approximately 30 km/h [20 mph].)

#### ■ Accelerating after setting the vehicle speed

The vehicle can accelerate by operating the accelerator pedal. After accelerating, the set speed resumes. However, during vehicle-to-vehicle distance control mode, the vehicle speed may decrease below the set speed in order to maintain the distance to the preceding vehicle.

#### ■ When the vehicle stops while follow-up cruising

- Pressing the “+RES” switch while the vehicle ahead stops will resume follow-up cruising if the vehicle ahead starts off within approximately 3 seconds after the switch is pressed.
- If the vehicle ahead starts off within 3 seconds after your vehicle stops, follow-up cruising will be resumed.

#### ■ Automatic cancelation of vehicle-to-vehicle distance control mode

Vehicle-to-vehicle distance control mode is automatically canceled in the following situations.

- VSC is activated.
- TRC is activated for a period of time.
- When the VSC or TRC system is turned off.
- The sensor cannot detect correctly because it is covered in some way.
- When the brake control or output restriction control of a driving support system operates. (For example: Pre-Collision System, Drive-Start Control)
- The parking brake is operated.
- The vehicle is stopped by system control on a steep incline.
- The following are detected when the vehicle has been stopped by system control:
  - The driver is not wearing a seat belt.

- The driver's door is opened.
- The vehicle has been stopped for about 3 minutes

If vehicle-to-vehicle distance control mode is automatically canceled for any reasons other than the above, there may be a malfunction in the system.

Contact your Toyota dealer.

#### ■ Automatic cancelation of constant speed control mode

Constant speed control mode is automatically canceled in the following situations:

- Actual vehicle speed is more than approximately 16 km/h (10 mph) below the set vehicle speed.
- Actual vehicle speed falls below approximately 30 km/h (20 mph).
- VSC is activated.
- TRC is activated for a period of time.
- When the VSC or TRC system is turned off.
- When the brake control or output restriction control of a driving support system operates.  
(For example: Pre-Collision System, Drive-Start Control)
- The parking brake is operated.

If constant speed control mode is automatically canceled for any reasons other than the above, there may be a malfunction in the system. Contact your Toyota dealer.

#### ■ The Dynamic Radar Cruise Control with Road Sign Assist may not operate properly when (vehicles with RSA)

As the Dynamic Radar Cruise Control with Road Sign Assist may not operate properly in conditions in which RSA may not operate or detect correctly (→P.233), when using this function, make sure to check the speed limit sign displayed.

In the following situations, the set speed

may not be changed to the recognized speed limit by pressing and holding the "+RES"/"-SET" switch.

- If speed limit information is not available
- When the recognized speed limit is the same as the set speed
- When the recognized speed limit is outside of the speed range that the dynamic radar cruise control system can operate

#### ■ Brake operation

A brake operation sound may be heard and the brake pedal response may change, but these are not malfunctions.

#### ■ Warning messages and buzzers for dynamic radar cruise control with full-speed range

Warning messages and buzzers are used to indicate a system malfunction or to inform the driver of the need for caution while driving. If a warning message is shown on the multi-information display, read the message and follow the instructions. (→P.208, 392)

#### ■ When the sensor may not be correctly detecting the vehicle ahead

In the case of the following and depending on the conditions, operate the brake pedal when deceleration of the system is insufficient or operate the accelerator pedal when acceleration is required.

As the sensor may not be able to correctly detect these types of vehicles, the approach warning (→P.241) may not be activated.

- Vehicles that cut in suddenly
- Vehicles traveling at low speeds
- Vehicles that are not moving in the same lane
- Vehicles with small rear ends (trailers with no load on board, etc.)

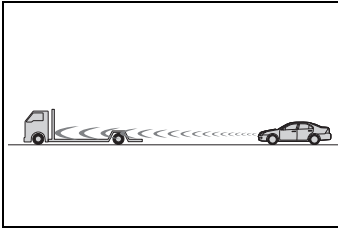

- Motorcycles traveling in the same lane
- When water or snow thrown up by the surrounding vehicles hinders the detecting of the sensor
- When your vehicle is pointing upwards (caused by a heavy load in the luggage compartment, etc.)

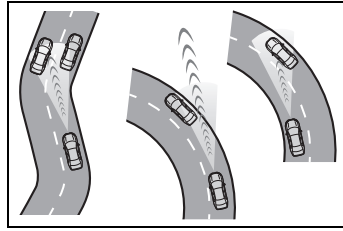

- When steering wheel operation or your position in the lane is unstable

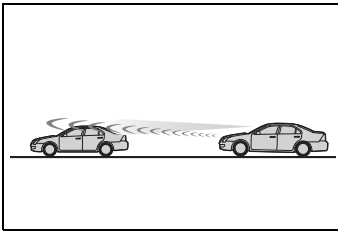

- Preceding vehicle has an extremely high ground clearance

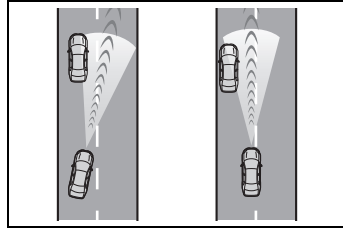

- When the vehicle ahead of you decelerates suddenly
- When driving on a road surrounded by a structure, such as in a tunnel or on a bridge
- While the vehicle speed is decreasing to the set speed after the vehicle accelerates by depressing the accelerator pedal

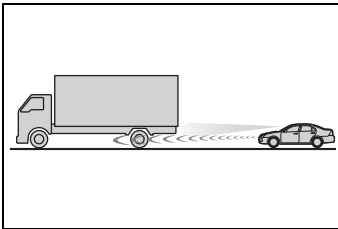

■ **Conditions under which the vehicle-to-vehicle distance control mode may not function correctly**

In the case of the following conditions, operate the brake pedal (or accelerator pedal, depending on the situation) as necessary.

As the sensor may not be able to correctly detect vehicles ahead, the system may not operate properly.

- When the road curves or when the lanes are narrow

## Cruise control\*

\*: If equipped

Use the cruise control to maintain a set speed without depressing the accelerator pedal.

### System components

#### ■ Meter display

- ▶ Vehicles with 7-inch multi-information display

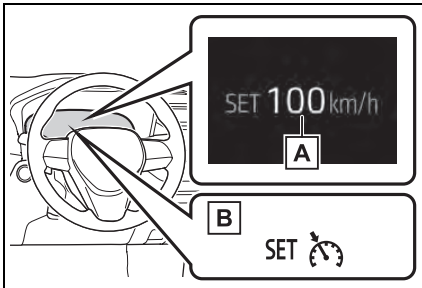

- A** Set speed
- B** Indicators

- ▶ Vehicles with 12.3-inch multi-information display

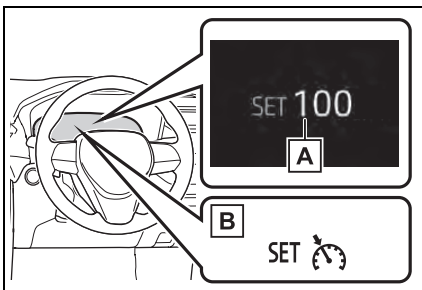

- A** Set speed
- B** Indicators

#### ■ Operation switches

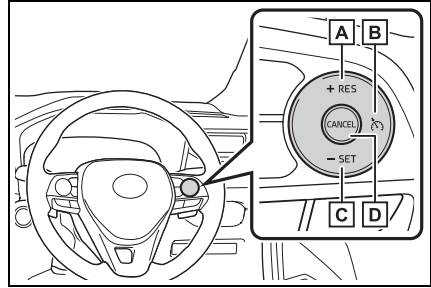

- A** "+RES" switch
- B** Cruise control main switch
- C** "-SET" switch
- D** Cancel switch

### ⚠ WARNING

#### ■ To avoid operating the cruise control by mistake

Switch the cruise control off using the cruise control main switch when not in use.

#### ■ Situations unsuitable for cruise control

Do not use cruise control in any of the following situations.

Doing so may result in loss of control and could cause an accident resulting in death or serious injury.

- In heavy traffic
- On roads with sharp bends
- On winding roads
- On slippery roads, such as those covered with rain, ice or snow
- On steep hills  
Vehicle speed may exceed the set speed when driving down a steep hill.



### ⚠ WARNING

- When your vehicle is towing a trailer\* or during emergency towing\*:  
\*: Vehicles that can tow a trailer.  
(→P.170)

## Setting the vehicle speed

- 1 Press the cruise control main switch to activate the cruise control.

Cruise control indicator will be displayed.

Press the switch again to deactivate the cruise control.

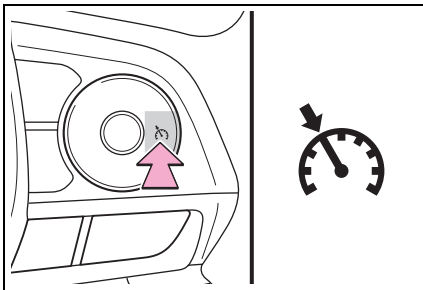

- 2 Accelerate or decelerate, with accelerator pedal operation, to the desired speed (at or above approximately 30 km/h [20 mph]) and press the “-SET” switch to set the speed.

Cruise control “SET” indicator will be displayed.

The vehicle speed at the moment the switch is released becomes the set

speed.

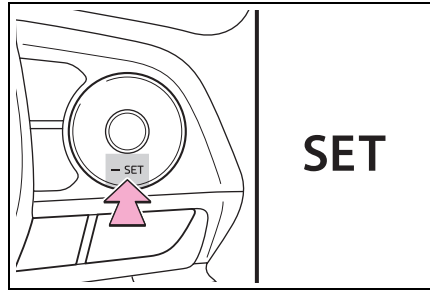

## Adjusting the set speed

To change the set speed, operate the “+RES” or “-SET” switch until the desired set speed is obtained.

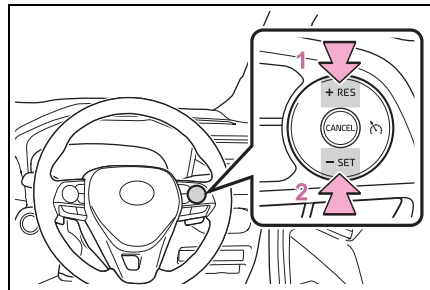

- 1 Increases the speed
- 2 Decreases the speed

Fine adjustment: Press the switch.

Large adjustment: Press and hold the switch to change the speed, and release when the desired speed is reached.

The set speed will be increased or decreased as follows:

Fine adjustment: By 1 km/h (0.6 mph) each time the switch is operated.

Large adjustment: The set speed can be increased or decreased continually until the switch is

released.

### Canceling and resuming the constant speed control

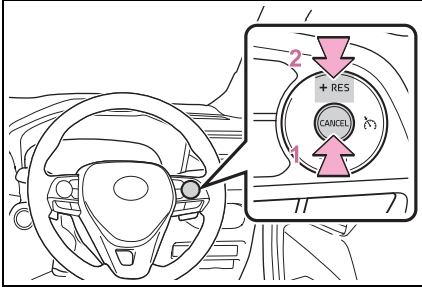

- 1 Pressing the cancel switch cancels the constant speed control.

The speed setting is also canceled when the brakes are applied.

- 2 Pressing the “+RES” switch resumes the constant speed control.

Resuming is available when the vehicle speed is more than approximately 30 km/h (20 mph).

#### ■ Cruise control can be set when

- The shift lever is in D.
- Vehicle speed is above approximately 30 km/h (20 mph).

#### ■ Accelerating after setting the vehicle speed

- The vehicle can be accelerated normally. After acceleration, the set speed resumes.
- Even without canceling the cruise control, the set speed can be increased by first accelerating the vehicle to the desired speed and then pushing the “-SET” switch to set the new speed.

#### ■ Automatic cancelation of cruise control

Cruise control will stop maintaining the vehicle speed in any of the following situations.

- Actual vehicle speed falls more than approximately 16 km/h (10 mph) below the preset vehicle speed.
- Actual vehicle speed is below approximately 30 km/h (20 mph).
- VSC is activated.
- TRC is activated for a period of time.
- When the VSC or TRC system is turned off.
- The parking brake is operated.

#### ■ If the warning message for the cruise control is shown on the multi-information display

Press the cruise control main switch once to deactivate the system, and then press the switch again to reactivate the system.

If the cruise control speed cannot be set or if the cruise control cancels immediately after being activated, there may be a malfunction in the cruise control system. Have the vehicle inspected by your Toyota dealer.

## BSM (Blind Spot Monitor)\*

\*: If equipped

The Blind Spot Monitor is a system that uses rear side radar sensors installed on the inner side of the rear bumper on the left and right side to assist the driver in confirming safety when changing lanes.

### WARNING

#### ■ Cautions regarding the use of the system

- The driver is solely responsible for safe driving. Always drive safely, taking care to observe your surroundings.
- The Blind Spot Monitor is a supplementary function which alerts the driver that a vehicle is in a blind spot of the outside rear view mirrors or is approaching rapidly from behind into a blind spot. Do not overly rely on the Blind Spot Monitor. As the function cannot judge if it is safe to change lanes, over reliance could lead to an accident resulting in death or serious injury. As the system may not function correctly under certain conditions, the driver's own visual confirmation of safety is necessary.

## System components

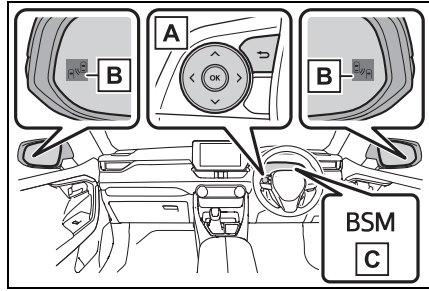

### A Meter control switches

Turning the Blind Spot Monitor on/off.

### B Outside rear view mirror indicators

When driving:

When a vehicle is detected in a blind spot of the outside rear view mirrors or approaching rapidly from behind into a blind spot, the outside rear view mirror indicator on the detected side will illuminate. If the turn signal lever is operated toward the detected side, the outside rear view mirror indicator flashes.

### C “BSM” indicator

When the BSM function is turned on, the indicator illuminates.

#### ■ Outside rear view mirror indicator visibility

In strong sunlight, the outside rear view mirror indicator may be difficult to see.

#### ■ When “Blind Spot Monitor Unavailable” is shown on the multi-information display

Ice, snow, mud, etc., may be attached to the rear bumper around the sensors. The system should return to normal operation after removing the ice, snow, mud, etc. from the rear bumper. Additionally, the sensors may not operate normally when driving in extremely hot

or cold environments.

■ **When “Blind Spot Monitor Malfunction Visit Your Dealer” is shown on the multi-information display**

There may be a sensor malfunction of misaligned. Have the vehicle inspected by your Toyota dealer.

■ **Customization**

Some functions can be customized.  
(→P.429)

**⚠ WARNING**

■ **To ensure the system can operate properly**

Blind Spot Monitor sensors are installed behind the left and right sides of the rear bumper respectively. Observe the following to ensure the Blind Spot Monitor can operate correctly.

- Keep the sensors and the surrounding areas on the rear bumper clean at all times.

If a sensor or its surrounding area on the rear bumper is dirty or covered with snow, the Blind Spot Monitor may not operate and a warning message (→P.249) will be displayed. In this situation, clear off the dirt or snow and drive the vehicle with the operation conditions of the BSM function (→P.252) satisfied for approximately 60 minutes. If the warning message does not disappear, have the vehicle inspected by your Toyota dealer.

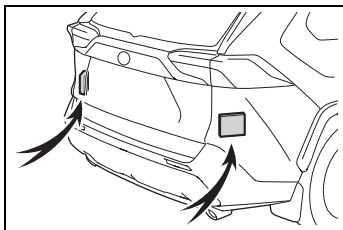

- Do not attach accessories, stickers (including transparent stickers), aluminum tape, etc. to a sensor or its surrounding area on the rear bumper.



- Do not subject a sensor or its surrounding area on the rear bumper to a strong impact.

If a sensor is moved even slightly off position, the system may malfunction and vehicles may not be detected correctly.

In the following situations, have your vehicle inspected by your Toyota dealer.

- A sensor or its surrounding area is subject to a strong impact.
- If the surrounding area of a sensor is scratched or dented, or part of them has become disconnected.
- Do not disassemble the sensor.
- Do not modify the sensor or surrounding area on the rear bumper.
- If a sensor or the rear bumper needs to be removed/installed or replaced, contact your Toyota dealer.
- Do not paint the rear bumper any color other than an official Toyota color.

### Turning the Blind Spot Monitor on/off

The Blind Spot Monitor  can be enabled/disabled on  of the multi-information display. (→P.429)

When the Blind Spot Monitor is enabled, the BSM indicator will illuminate.

## Blind Spot Monitor operation

### ■ Objects that can be detected while driving

The Blind Spot Monitor uses rear side radar sensors to detect the following vehicles traveling in adjacent lanes and advises the driver of the presence of such vehicles via the indicators on the outside rear view mirrors.

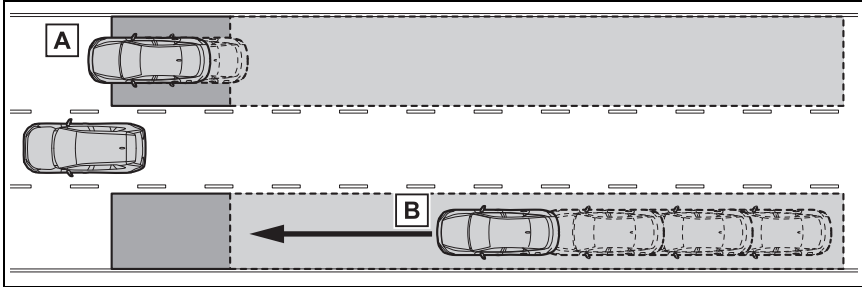

- A** Vehicles that are traveling in areas that are not visible using the outside rear view mirrors (the blind spots)
- B** Vehicles that are approaching rapidly from behind in areas that are not visible using the outside rear view mirrors (the blind spots)

### ■ Detection range while driving

The areas that vehicles can be detected in are outlined below.

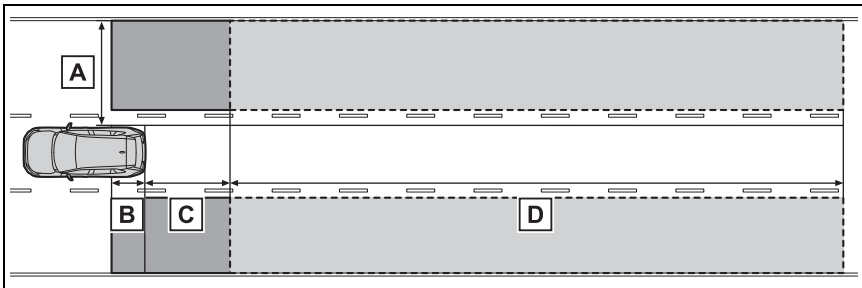

The range of each detection area is:

- A** Approximately 0.5 m (1.6 ft.) to 3.5 m (11.5 ft.) from either side of the vehicle\*<sup>1</sup>
- B** Approximately 1 m (3.3 ft.) forward of the rear bumper
- C** Approximately 3 m (9.8 ft.) from the rear bumper
- D** Approximately 3 m (9.8 ft.) to 60 m (197 ft.) from the rear bumper\*<sup>2</sup>

\*1: The area between the side of the vehicle and 0.5 m (1.6 ft.) from the side of the vehicle cannot be detected.

\*2: The greater the difference in speed between your vehicle and the detected vehicle is, the farther away the vehicle will be detected, causing the outside rear view mirror indicator to illuminate or flash.

### ■ The Blind Spot Monitor is operational when

The Blind Spot Monitor is operational when all of the following conditions are met:

- The power switch is in ON.
- The Blind Spot Monitor is on.
- The shift lever is in a position other than R.
- The vehicle speed is approximately 10 km/h (7 mph) or more (while driving).

### ■ The Blind Spot Monitor will detect a vehicle when

The Blind Spot Monitor will detect a vehicle present in the detection area in the following situations:

- A vehicle in an adjacent lane overtakes your vehicle.
- You overtake a vehicle in an adjacent lane slowly.
- Another vehicle enters the detection area when it changes lanes.

### ■ Situations in which the Blind Spot Monitor cannot detect vehicles (while driving)

The Blind Spot Monitor cannot detect the following vehicles and other objects (while driving):

- Small motorcycles, bicycles, pedestrians, etc.\*
- Vehicles traveling in the opposite direction
- Guardrails, walls, signs, parked vehicles and similar stationary objects\*
- Following vehicles that are in the same lane\*
- Vehicles traveling 2 lanes away from

your vehicle\*

- Vehicles which are being overtaken rapidly by your vehicle\*

\*: Depending on the conditions, detection of a vehicle and/or object may occur.

### ■ Conditions under which the system may not function correctly

- In the following situations, vehicles may not be detected correctly (while driving):
  - When the sensor is misaligned due to a strong impact to the sensor or its surrounding area
  - When mud, snow, ice, a sticker, etc., is covering the sensor or surrounding area on the rear bumper
  - When driving on a road surface that is wet with standing water during bad weather, such as heavy rain, snow, or fog
  - When multiple vehicles are approaching with only a small gap between each vehicle
  - When the distance between your vehicle and a following vehicle is short
  - When there is a significant difference in speed between your vehicle and the vehicle that enters the detection area
  - When the difference in speed between your vehicle and another vehicle is changing
  - When a vehicle enters a detection area traveling at about the same speed as your vehicle
  - As your vehicle starts from a stop, a vehicle remains in the detection area
  - When driving up and down consecutive steep inclines, such as hills, dips in the road, etc.
  - When driving on roads with sharp bends, consecutive curves, or uneven

surfaces

- When vehicle lanes are wide, or when driving on the edge of a lane, and the vehicle in an adjacent lane is far away from your vehicle
- When an accessory (such as a bicycle carrier) is installed to the rear of the vehicle
- When there is a significant difference in height between your vehicle and the vehicle that enters the detection area
- Immediately after the Blind Spot Monitor is turned on
- When towing with the vehicle
- Instances of unnecessary detection may increase in situations such as the following (while driving):
- When the sensor is misaligned due to a strong impact to the sensor or its surrounding area
- When the distance between your vehicle and a guardrail, wall, etc. that enters the detection area is short
- When driving up and down consecutive steep inclines, such as hills, dips in the road, etc.
- When vehicle lanes are narrow, or when driving on the edge of a lane, and a vehicle traveling in a lane other than the adjacent lanes enters the detection area
- When driving on roads with sharp bends, consecutive curves, or uneven surfaces
- When the tires are slipping or spinning
- When the distance between your vehicle and a following vehicle is short
- When an accessory (such as a bicycle carrier) is installed to the rear of the vehicle
- When towing with the vehicle

## Toyota parking assist-sensor

The distance from your vehicle to objects, such as a wall, when parallel parking or maneuvering into a garage is measured by the sensors and communicated via the multi-information display or Multi-media Display and a buzzer. Always check the surrounding area when using this system.

## System components

### ■ Location and types of sensors

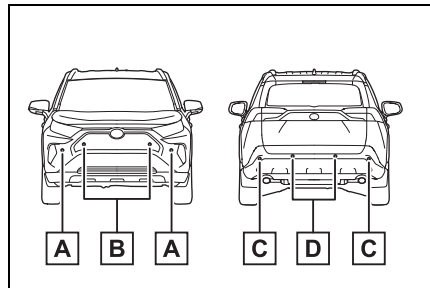

**A** Front corner sensors

**B** Front center sensors

**C** Rear corner sensors

**D** Rear center sensors

### ■ Display (Multi-information display)

When the sensors detect an object, such as a wall, a graphic is shown on the multi-information display depending on the position and distance to the object.

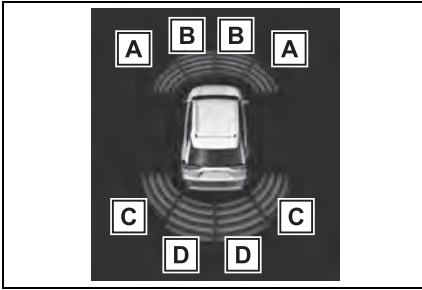

- A** Front corner sensor detection
- B** Front center sensor detection\*<sup>1</sup>
- C** Rear corner sensor detection\*<sup>2</sup>
- D** Rear center sensor detection\*<sup>2</sup>

\*<sup>1</sup>: Displayed when the shift lever is in a driving position

\*<sup>2</sup>: Displayed when the shift lever is in R

#### ■ Display (Multimedia Display)

When the sensors detect an object, such as a wall, a graphic is shown on the Multimedia Display depending on the position and distance to the object.

- When the Toyota parking assist monitor (if equipped) is displayed

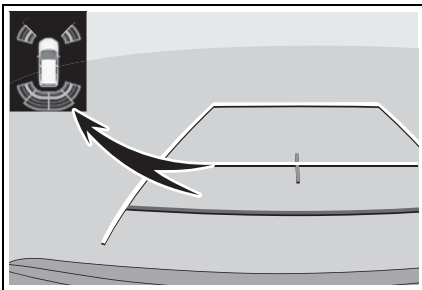

A simplified image is displayed on the upper corner of the screen when an obstacle is detected.

- When the panoramic view moni-

tor (if equipped) is displayed

- ▶ Panoramic view

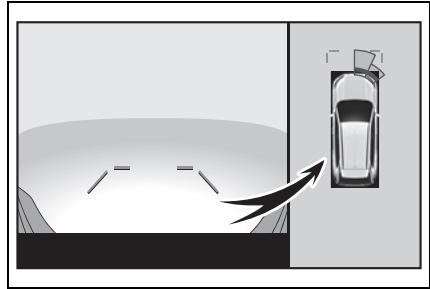

A graphic is shown when the panoramic view monitor is displayed.

- ▶ Except panoramic view

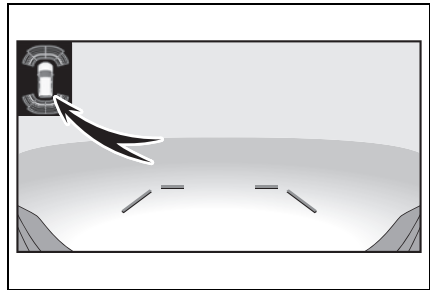

A simplified image is displayed on the upper corner of the screen when an obstacle is detected.

### Turning Toyota parking assist-sensor on/off

The Toyota parking assist-sensor function can be enabled/disabled on the  screen of the multi-information display. (→P.94, 103)

When the Toyota parking assist-sensor function is disabled, the Toyota parking assist-sensor OFF indicator (→P.76) illuminates on the multi-information display.



To re-enable the system, select  on the multi-information display, select



and turn it on.

If the system is disabled, it will remain off even if the power switch is turned to ON after the power switch has been turned off.



## WARNING

### ■ Cautions regarding the use of the system

There is a limit to the degree of recognition accuracy and control performance that this system can provide, do not overly rely on this system. The driver is always responsible for paying attention to the vehicle's surroundings and driving safely.

### ■ To ensure the system can operate properly

Observe the following precautions. Failing to do so may result in the vehicle being unable to be driven safely and possibly cause an accident.

- Do not damage the sensors, and always keep them clean.
- Do not attach a sticker or install an electronic component, such as a backlit license plate (especially fluorescent type), fog lights, fender pole or wireless antenna near a radar sensor.
- Do not subject the surrounding area of the sensor to a strong impact. If subjected to an impact, have the vehicle inspected by your Toyota dealer. If the front or rear bumper needs to be removed/installed or replaced, contact your Toyota dealer.
- Do not modify, disassemble or paint the sensors.
- Do not attach a license plate cover.

- Keep your tires properly inflated.

### ■ When to disable the function

In the following situations, disable the function as it may operate even though there is no possibility of a collision.

- Failing to observe the warnings above.
- A non-genuine Toyota suspension (lowered suspension, etc.) is installed.

### ■ Notes when washing the vehicle

Do not apply intensive bursts of water or steam to the sensor area.

Doing so may result in the sensor malfunctioning.

- When using a high pressure washer to wash the vehicle, do not spray the sensors directly, as doing so may cause a sensor to malfunction.
- When using steam to clean the vehicle, do not direct steam too close to the sensors as doing so may cause a sensor to malfunction.

### ■ The system can be operated when

- The power switch is in ON.
- Toyota parking assist-sensor function is on.
- The vehicle speed is less than about 10 km/h (6 mph).
- The shift lever is in other than P.

### ■ If “Parking Assist Unavailable Clean Parking Assist Sensor” is displayed on the multi-information display

A sensor may be covered with ice, snow, dirt, etc. Remove the ice, snow, dirt, etc., from the sensor to return the system to normal.

Also, due to ice forming on a sensor at low temperatures, a warning message may be displayed or the sensor may not

be able to detect an object. Once the ice melts, the system will return to normal. If a warning message is displayed even if the sensor is clean, there may be a sensor malfunction. Have the vehicle inspected by your Toyota dealer.

■ **If “Parking Assist Unavailable” is displayed on the multi-information display (vehicles with PKSB)**

Water may be continuously flowing over the sensor surface, such as in a heavy rain. When the system determines that it is normal, the system will return to normal.

■ **Sensor detection information**

- The sensor’s detection areas are limited to the areas around the vehicle’s front and rear bumpers.
- The following situations may occur during use.
  - Depending on the shape of the object and other factors, the detection distance may shorten, or detection may be impossible.
  - Detection may be impossible if static objects draw too close to the sensor.
  - There will be a short delay between static object detection and display (warning buzzer sounds). Even at low speeds, there is a possibility that the object will come within 30 cm (11.9 in.) before the display is shown and the warning buzzer sounds.
  - It might be difficult to hear the buzzer due to the volume of the audio system or air flow noise of the air conditioning system.
  - It may be difficult to hear the sound of this system due to the buzzers of other systems.

■ **Objects which the system may not properly detect**

The shape of the object may prevent the sensor from detecting it. Pay particular attention to the following objects:

- Wires, fences, ropes, etc.
- Cotton, snow and other materials that absorb sound waves

- Sharply-angled objects
- Low objects
- Tall objects with upper sections projecting outwards in the direction of your vehicle

People may not be detected if they are wearing certain types of clothing.

■ **Situations in which the system may not operate properly**

Certain vehicle conditions and the surrounding environment may affect the ability of a sensor to correctly detect objects. Particular instances where this may occur are listed below.

- There is dirt, snow or ice on a sensor. (Cleaning the sensors will resolve this problem.)
- A sensor is frozen. (Thawing the area will resolve this problem.)  
In especially cold weather, if a sensor is frozen the sensor display may be displayed abnormally, or objects, such as a wall, may not be detected.
- When a sensor or the area around a sensor is extremely hot or cold.

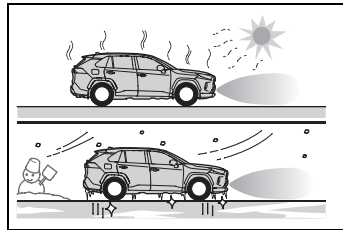

- On an extremely bumpy road, on an incline, on gravel, or on grass.
- When vehicle horns, vehicle detectors, motorcycle engines, air brakes of large vehicles, the clearance sonar of other vehicles or other devices which produce ultrasonic waves are near the vehicle.
- A sensor is coated with a sheet of spray or heavy rain.
- If objects draw too close to the sensor.
- When a pedestrian is wearing clothing that does not reflect ultrasonic waves

(ex. skirts with gathers or frills).

- When objects that are not perpendicular to the ground, not perpendicular to the vehicle traveling direction, uneven, or waving are in the detection range.
- Strong wind is blowing.
- When driving in inclement weather such as fog, snow or a sandstorm.
- When an object that cannot be detected is between the vehicle and a detected object.
- If an object such as a vehicle, motorcycle, bicycle or pedestrian cuts in front of the vehicle or runs out from the side of the vehicle.
- If the orientation of a sensor has been changed due to a collision or other impact.
- When equipment that may obstruct a sensor is installed, such as a towing eyelet, bumper protector (an additional trim strip, etc.), bicycle carrier, or snow plow.
- If the front of the vehicle is raised or lowered due to the carried load.
- If the vehicle cannot be driven in a stable manner, such as when the vehicle has been in an accident or is malfunctioning.
- When tire chains, a compact spare tire or an emergency tire puncture repair kit are used.

■ **Situations in which the system may operate even if there is no possibility of a collision**

In some situations, such as the following, the system may operate even though there is no possibility of a collision.

- When driving on a narrow road.

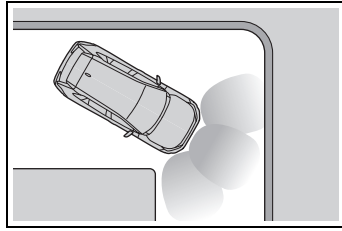

- When driving toward a banner, flag, low-hanging branch or boom barrier (such as those used at railroad crossings, toll gates and parking lots).
- When there is a rut or hole in the surface of the road.
- When driving on a metal cover (grating), such as those used for drainage ditches.
- When driving up or down a steep slope.
- If a sensor is hit by a large amount of water, such as when driving on a flooded road.
- There is dirt, snow, water drops or ice on a sensor. (Cleaning the sensors will resolve this problem.)
- A sensor is coated with a sheet of spray or heavy rain.
- When driving in inclement weather such as fog, snow or a sandstorm.
- When strong winds are blowing.

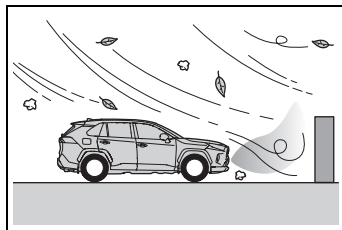

- When vehicle horns, vehicle detectors, motorcycle engines, air brakes of large vehicles, the clearance sonar of other vehicles or other devices which produce ultrasonic waves are near the vehicle.
- If the front of the vehicle is raised or lowered due to the carried load.

- If the orientation of a sensor has been changed due to a collision or other impact.
- The vehicle is approaching a tall or curved curb.
- Driving close to columns (H-shaped steel beams, etc.) in multi-story parking garages, construction sites, etc.
- If the vehicle cannot be driven in a stable manner, such as when the vehicle has been in an accident or is malfunctioning.
- On an extremely bumpy road, on an incline, on gravel, or on grass.

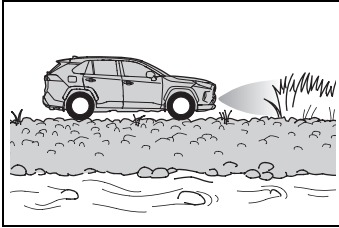

- When tire chains, a compact spare tire or an emergency tire puncture repair kit are used.

### Sensor detection display, object distance

#### ■ Detection range of the sensors

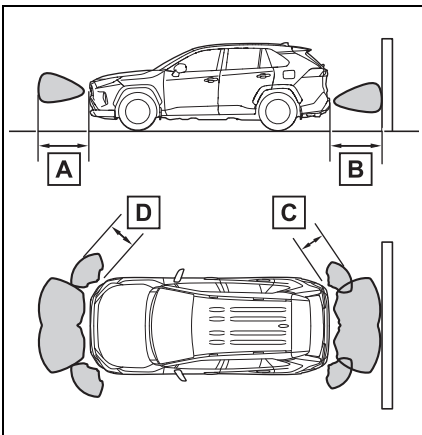

#### ▶ Vehicles without PKSB

- A** Approximately 100 cm (3.3 ft.)
- B** Approximately 150 cm (4.9 ft.)
- C** Approximately 65 cm (2.12 ft.)
- D** Approximately 60 cm (1.96 ft.)

#### ▶ Vehicles with PKSB

- A** Approximately 100 cm (3.3 ft.)
- B** Approximately 150 cm (4.9 ft.)
- C** Approximately 63 cm (2.06 ft.)
- D** Approximately 63 cm (2.06 ft.)

The diagram shows the detection range of the sensors. Note that the sensors cannot detect objects that are extremely close to the vehicle.

The range of the sensors may change depending on the shape of the object, etc.

■ **Distance display**





When an object is detected by a sensor, the approximate distance to the object will be displayed on the multi-information display or Multimedia Display. (As the distance to the object becomes short, the distance segments may blink.)

The images may differ from that shown in the illustrations.

▶ **Vehicles without PKSB**

● **Approximate distance to object**

- Front center sensor: 100 cm (3.3 ft.) to 60 cm (1.96 ft.)
- Rear center sensor: 150 cm (4.9 ft.) to 65 cm (2.12 ft.)





Multi-information display		Multimedia Display	
 *1	 *2		

\*1: Vehicles with 7-inch multi-information display

\*2: Vehicles with 12.3-inch multi-information display

● **Approximate distance to object**

- Front sensor: 60 cm (1.96 ft.) to 47.5 cm (1.56 ft.)
- Rear sensor: 65 cm (2.12 ft.) to 50 cm (1.63 ft.)





Multi-information display		Multimedia Display	
 *1	 *2		

\*1: Vehicles with 7-inch multi-information display

\*2: Vehicles with 12.3-inch multi-information display

● **Approximate distance to object**





- Front sensor: 47.5 cm (1.56 ft.) to 35 cm (1.14 ft.)
- Rear sensor: 50 cm (1.63 ft.) to 35 cm (1.14 ft.)

Multi-information display		Multimedia Display	
 *1	 *2		

\*1: Vehicles with 7-inch multi-information display

\*2: Vehicles with 12.3-inch multi-information display

- Approximate distance to object: 35 cm (1.14 ft.) to 28 cm (0.9 ft.)





Multi-information display *3		Multimedia Display	
 *1	 *2		

\*1: Vehicles with 7-inch multi-information display

\*2: Vehicles with 12.3-inch multi-information display

\*3: The distance segments will blink slowly.

- Approximate distance to object: Less than 28 cm (0.9 ft.)

Multi-information display *3		Multimedia Display	
 *1	 *2		

\*1: Vehicles with 7-inch multi-information display

\*2: Vehicles with 12.3-inch multi-information display





\*3: The distance segments will blink rapidly.

► Vehicles with PKSB

- Approximate distance to object

- Front center sensor: 100 cm (3.3 ft.) to 63 cm (2.06 ft.)





- Rear center sensor: 150 cm (4.9 ft.) to 63 cm (2.06 ft.)

Multi-information display		Multimedia Display	
 *1	 *2		

\*1: Vehicles with 7-inch multi-information display

\*2: Vehicles with 12.3-inch multi-information display





- Approximate distance to object: 63 cm (2.06 ft.) to 48 cm (1.57 ft.)

Multi-information display		Multimedia Display	
 *1	 *2		

\*1: Vehicles with 7-inch multi-information display

\*2: Vehicles with 12.3-inch multi-information display





- Approximate distance to object: 48 cm (1.57 ft.) to 34 cm (1.11 ft.)

Multi-information display		Multimedia Display	
 *1	 *2		

\*1: Vehicles with 7-inch multi-information display

\*2: Vehicles with 12.3-inch multi-information display

- Approximate distance to object: 34 cm (1.11 ft.) to 15 cm (0.5 ft.)





Multi-information display*3		Multimedia Display	
 *1	 *2		

\*1: Vehicles with 7-inch multi-information display

\*2: Vehicles with 12.3-inch multi-information display

\*3: The distance segments will blink slowly.

- Approximate distance to object: Less than 15 cm (0.5 ft.)

Multi-information display*3		Multimedia Display	
 *1	 *2		

\*1: Vehicles with 7-inch multi-information display

\*2: Vehicles with 12.3-inch multi-information display

\*3: The distance segments will blink rapidly.

### ■ Buzzer operation and distance to an object

A buzzer sounds when the sensors are operating.

- The buzzer beeps faster as the vehicle approaches an object. When the vehicle comes within the following distance of the object, the buzzer sounds continuously.
  - Vehicles without PKSB: Approximately 35 cm (1.14 ft.)
  - Vehicles with PKSB: Approximately 34 cm (1.11 ft.)
- When 2 or more sensors simultaneously detect a static object, the buzzer sounds for the nearest object.
- Vehicles with PKSB: Even when the sensors are operating, the buzzer will be muted in some situations. (automatic buzzer mute function)

### ■ Muting the buzzer sound (vehicles with PKSB)

- Automatic buzzer mute function

Even when the sensors are operating, the buzzer will be muted in the following situations:

- The distance between the vehicle and the detected object does not become shorter (except when the distance between the vehicle and object is 34 cm [1.11 ft.] or less).
- Your vehicle is moving away from the object.
- There are no detectable objects entering the path of your vehicle.

However, if another object is detected or the situation changes while the buzzer is

muted, the buzzer begins sounding again.

- To mute the buzzer sound  
The buzzer can be temporarily muted by

pressing  of the meter control switches while a suggestion that says mute is available is shown on the multi-information display.

- When the mute is canceled  
Mute will be automatically canceled in the following situations.
  - When the shift position is changed
  - When the vehicle speed has reached or exceeded a certain speed
  - When the Toyota parking assist is turned off once and turned on again
  - When the power switch is turned off once and turned to ON again

### ■ Customization

The buzzer volume can be adjusted on the multi-information display. (→P.94, 103)



## RCTA (Rear Cross Traffic Alert) function\*

\*: If equipped

The RCTA function uses the BSM rear side radar sensors installed behind the rear bumper. This function is intended to assist the driver in checking areas that are not easily visible when backing up.

### WARNING

#### ■ Cautions regarding the use of the system

The driver is solely responsible for safe driving. Always drive safely, taking care to observe your surroundings.

The RCTA function is only a supplementary function which alerts the driver that a vehicle is approaching from the right or left at the rear of the vehicle.

As the RCTA function may not function correctly under certain conditions, the driver's own visual confirmation of safety is necessary.

Over reliance on this function may lead to an accident resulting death or serious injury.

### System components

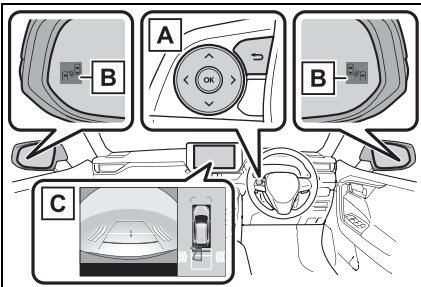

#### **A** Meter control switches

Turning the RCTA function on/off.

When the RCTA function is disabled, the RCTA OFF indicator illuminates.

#### **B** Outside rear view mirror indicators

If a vehicle is detected as approaching from the left or right behind the vehicle, both outside rear view mirror indicators will blink and a buzzer will sound.

#### **C** Multimedia display

If a vehicle approaching from the right or left at the rear of the vehicle is detected, the RCTA icon (→P.264) for the detected side will be displayed on the Multimedia display. This illustration shows an example of a vehicle approaching from both sides of the vehicle.

### Turning the RCTA function on/off

The RCTA can be enabled/disabled on  of the multi-information display. (→P.429)

When the RCTA function is disabled, the RCTA OFF indicator (→P.76) illuminates. (Each time the power switch is turned to OFF then changed to ON, the RCTA function will be enabled automatically.)

#### ■ Outside rear view mirror indicator visibility

In strong sunlight, the outside rear view mirror indicator may be difficult to see.

#### ■ Hearing the RCTA buzzer

The RCTA buzzer may be difficult to

hear over loud noises, such as if the audio system volume is high.

■ **When “Rear Cross Traffic Alert Unavailable” is shown on the multi-information display**

Ice, snow, mud, etc., may be attached to the rear bumper around the sensors. (→P.250) Removing the ice, snow, mud, etc., from the attached to the rear bumper around the sensors to normal. Additionally, the function may not function normally when used in extremely hot or cold environments.

■ **When “Rear Cross Traffic Alert Malfunction Visit Your Dealer” is shown on the multi-information display**

There may be a sensor malfunction or misaligned. Have the vehicle inspected at a Toyota dealer.

■ **Rear side radar sensors**

→P.250

## RCTA function

■ **Operation of the RCTA function**

The RCTA function uses rear side radar sensors to detect vehicles approaching from the right or left at the rear of the vehicle and alerts the driver of the presence of such vehicles by flashing the outside rear view mirror indicators and sounding a buzzer.

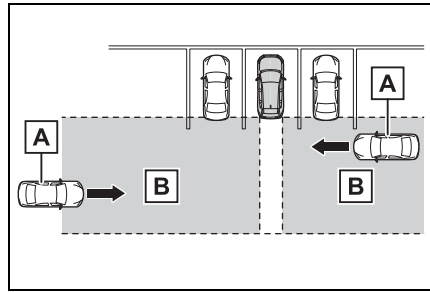

**A** Approaching vehicles

**B** Detection areas of approaching vehicles

■ **RCTA icon display**

When a vehicle approaching from the right or left at the rear of the vehicle is detected, the following will be displayed on the Multimedia display.

- Example (Panoramic view monitor) (if equipped): Vehicles are approaching from both sides of the vehicle

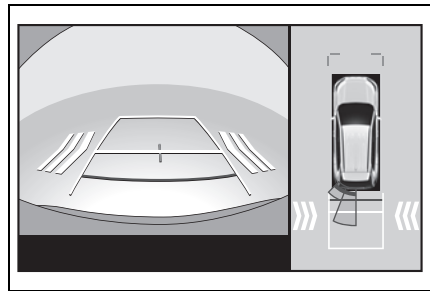

■ **RCTA function detection areas**

The areas that vehicles can be detected in are outlined below.

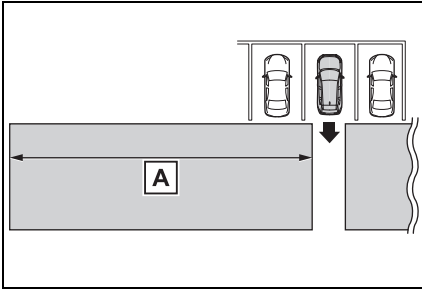

The buzzer can alert the driver of faster vehicles approaching from farther away.

Example:

Approaching vehicle speed	<b>A</b> Approximate alert distance
56 km/h (34 mph) (fast)	30 m (98 ft.)
8 km/h (5 mph) (slow)	4 m (13 ft.)

#### ■ The RCTA function is operational when

The RCTA function operates when all of the following conditions are met:

- The power switch is in ON.
- The RCTA function is on.
- The shift lever is in R.
- The vehicle speed is less than approximately 15 km/h (9 mph).
- The approaching vehicle speed is between approximately 8 km/h (5 mph) and 56 km/h (34 mph).

#### ■ Setting the buzzer volume

The buzzer volume can be adjusted on the multi-information display.

The volume of the RCTA buzzer can be adjusted on  of the multi-information display. (→P.429)

#### ■ Muting a buzzer temporarily

A mute button will be displayed on the multi-information display when a vehicle or an object is detected. To mute the buzzer, press .

The buzzers for the RCTA function and Toyota parking assist-sensor will be muted simultaneously.

Mute will be canceled automatically in the following situations:

- When the shift lever is changed.
- When the vehicle speed exceeds a certain speed.
- When there is a malfunction in a sensor or the system is temporarily unavailable.
- When the operating function is disabled manually.
- When the power switch is turned off.

#### ■ Conditions under which the system will not detect a vehicle

The RCTA function is not designed to detect the following types of vehicles and/or objects:

- Vehicles approaching from directly behind
- Vehicles backing up in a parking space next to your vehicle
- Vehicles that the sensors cannot detect due to obstructions

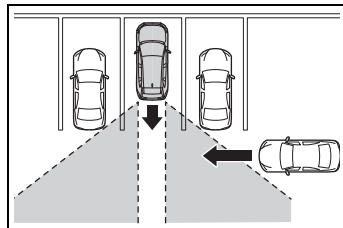

- Guardrails, walls, signs, parked vehicles and similar stationary objects\*
- Small motorcycles, bicycles, pedestrians, etc.\*
- Vehicles moving away from your vehicle

- Vehicles approaching from the parking spaces next to your vehicle\*
  - The distance between the sensor and approaching vehicle gets too close
- \*: Depending on the conditions, detection of a vehicle and/or object may occur.

### ■ Situations in which the system may not operate properly

The RCTA function may not detect vehicles correctly in the following situations:

- When the sensor is misaligned due to a strong impact to the sensor or its surrounding area
- When mud, snow, ice, a sticker, etc., is covering the sensor or surrounding area on the rear bumper
- When driving on a road surface that is wet with standing water during bad weather, such as heavy rain, snow, or fog
- When multiple vehicles are approaching with only a small gap between each vehicle
- When a vehicle is approaching at high speed
- When equipment that may obstruct a sensor is installed, such as a towing eyelet, bumper protector (an additional trim strip, etc.), bicycle carrier, or snow plow
- When backing up on a slope with a sharp change in grade

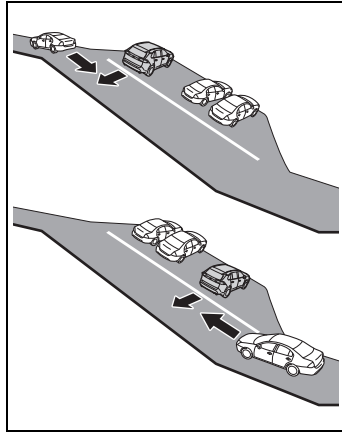

- When backing out of a sharp angle parking spot

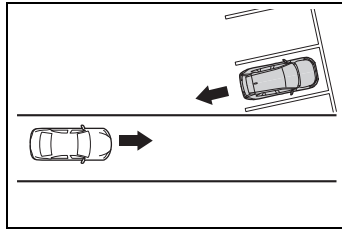

- Immediately after the RCTA function is turned on
- Immediately after the hybrid system is started with the RCTA function on
- When the sensors cannot detect a vehicle due to obstructions
- When towing a trailer
- When there is a significant difference in height between your vehicle and the vehicle that enters the detection area
- When a sensor or the area around a sensor is extremely hot or cold
- If the suspension has been modified or tires of a size other than specified are installed
- If the front of the vehicle is raised or lowered due to the carried load
- When turning while backing up

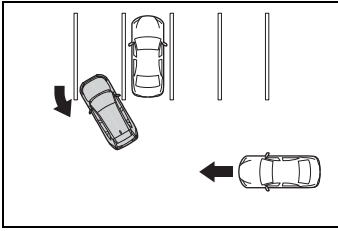

- When a vehicle turns into the detection area

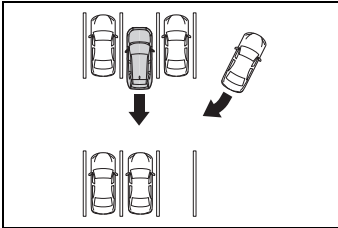

■ Situations in which the system may operate even if there is no possibility of a collision

Instances of the RCTA function unnecessarily detecting a vehicle and/or object may increase in the following situations:

- When the parking space faces a street and vehicles are being driven on the street

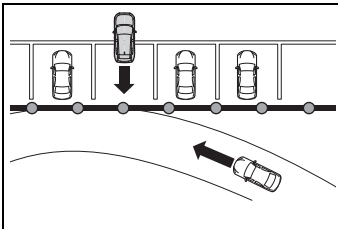

- When the distance between your vehicle and metal objects, such as a guardrail, wall, sign, or parked vehicle, which may reflect electrical waves toward the rear of the vehicle, is short

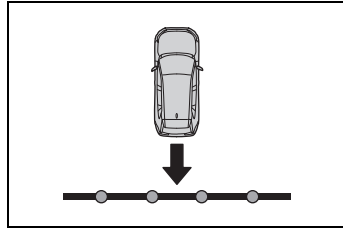

- When equipment that may obstruct a sensor is installed, such as a towing eyelet, bumper protector (an additional trim strip, etc.), bicycle carrier, or snow plow
- When a vehicle passes by the side of your vehicle

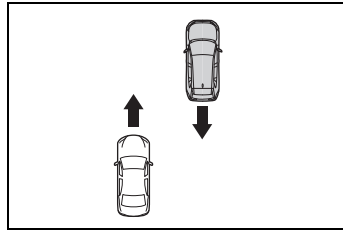

- When a detected vehicle turns while approaching the vehicle

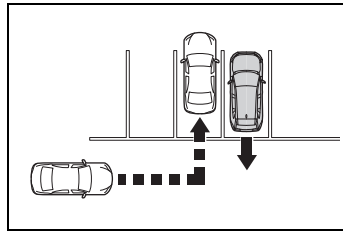

- When there are spinning objects near your vehicle such as the fan of an air conditioning unit
- When water is splashed or sprayed toward the rear bumper, such as from a sprinkler
- Moving objects (flags, exhaust fumes, large rain droplets or snowflakes, rain water on the road surface, etc.)
- When the distance between your vehicle and a guardrail, wall, etc., that enters the detection area is short
- Gratings and gutters

- When a sensor or the area around a sensor is extremely hot or cold
- If the suspension has been modified or tires of a size other than specified are installed
- If the front of the vehicle is raised or lowered due to the carried load

### **PKSB (Parking Support Brake)\***

\*: If equipped

**The Parking Support Brake system consists of the following functions that operate when driving at a low speed or backing up, such as when parking. When the system determines that the possibility of a collision with a detected object is high, a warning operates to urge the driver to take evasive action. If the system determines that the possibility of a collision with a detected object is extremely high, the brakes are automatically applied to help avoid the collision or help reduce the impact of the collision.**

### **PKSB (Parking Support Brake) system**

- **Parking Support Brake function (static objects)**  
→P.273
- **Parking Support Brake function (rear-crossing vehicles)**  
→P.276

**WARNING****■ Cautions regarding the use of the system**

Do not overly rely on the system, as doing so may lead to an accident.

Always drive while checking the safety of the surroundings of the vehicle.

Depending on the vehicle and road conditions, weather, etc., the system may not operate.

The detection capabilities of sensors and radars are limited. Always drive while checking the safety of the surroundings of the vehicle.

- The driver is solely responsible for safe driving. Always drive carefully, taking care to observe your surroundings. The Parking Support Brake system is designed to provide support to lessen the severity of collisions. However, it may not operate in some situations.
- The Parking Support Brake system is not designed to stop the vehicle completely. Additionally, even if the system has stopped the vehicle, it is necessary to depress the brake pedal immediately as brake control will be canceled after approximately 2 seconds.
- It is extremely dangerous to check the system operations by intentionally driving the vehicle into the direction of a wall, etc. Never attempt such actions.

**■ When to disable the Parking Support Brake**

In the following situations, disable the Parking Support Brake as the system may operate even though there is no possibility of a collision.

- When inspecting the vehicle using a chassis roller, chassis dynamo or free roller.

- When loading the vehicle onto a boat, truck or other transport vessel.
- If the suspension has been modified or tires of a size other than specified are installed.
- If the front of the vehicle is raised or lowered due to the carried load.
- When equipment that may obstruct a sensor is installed, such as a towing eyelet, bumper protector (an additional trim strip, etc.), bicycle carrier, or snow plow.
- When using automatic car washing devices.
- If the vehicle cannot be driven in a stable manner, such as when the vehicle has been in an accident or is malfunctioning.
- When the vehicle is driven in a sporty manner or off-road.
- When the tires are not properly inflated.
- When the tires are very worn.
- When tire chains, a compact spare tire or an emergency tire puncture repair kit are used.
- When your vehicle is towing a trailer (for Australia and New Zealand) or during emergency towing.

**NOTICE**

- If “PKSB Unavailable” is displayed on the multi-information display and the PKSB OFF indicator is flashing

If this message is displayed immediately after the power switch is changed to ON, operate the vehicle carefully, paying attention to your surroundings. It may be necessary to drive the vehicle for a certain amount of time before the system returns to normal. (If the system does not return to normal after driving for a while, clean the sensors and their surrounding area on the bumpers.)

### Enabling/Disabling the Parking Support Brake

The Parking Support Brake can be enabled/disabled on the  screen of the multi-information display. All of the Parking Support Brake functions (static objects and rear-crossing vehicles) are enabled/disabled simultaneously. (→P.94, 103)

When the Parking Support Brake is disabled, the PKSB OFF indicator (→P.76) illuminates on the multi-information display.

To re-enable the system, select  on the multi-information display, select



and turn it on.

If the system is disabled, it will remain off even if the power switch is turned to ON after the power switch has been turned off.

### Display and buzzer for hybrid system output restriction control and brake control

If the hybrid system output restriction control or brake control operates, a buzzer will sound and a message will be displayed on the multi-information display or Multimedia Display, to alert the driver.

Depending on the situation, hybrid system output restriction control will operate to either limit acceleration or restrict output as much as possible.

- Hybrid system output restriction control is operating (acceleration restriction)

Acceleration greater than a certain amount is restricted by the system.

Multimedia Display: No warning displayed

Multi-information display: “Object Detected Acceleration Reduced”

PKSB OFF indicator: Not illuminated

Buzzer: Does not sound

- Hybrid system output restriction control is operating (output restricted as much as possible)

The system has determined that stronger-than-normal brake operation is necessary.

Multimedia Display: “BRAKE!”

Multi-information display: “BRAKE!”

PKSB OFF indicator: Not illuminated

Buzzer: Short beep

- Brake control is operating

The system determined that emer-



gency braking is necessary.

Multimedia Display: "BRAKE!"

Multi-information display: "BRAKE!"

PKSB OFF indicator: Not illuminated

Buzzer: Short beep

- Vehicle stopped by system operation

The vehicle has been stopped by brake control operation.

Multimedia Display: "Press Brake Pedal"

Multi-information display: "Switch to Brake" (If the accelerator pedal is not depressed, "Press Brake Pedal" will be displayed.)

PKSB OFF indicator: Illuminated

Buzzer: Short beep

### System overview

If the Parking Support Brake determines that a collision with a detected object is possible, the hybrid system output will be restricted to restrain any increase in the vehicle speed. (Hybrid system output restriction control: See figure 2.)

Additionally, if the accelerator pedal continues to be depressed, the brakes will be applied automatically to reduce the vehicle speed. (Brake control: See figure 3.)

- Figure 1: When the PKSB (Parking Support Brake) is not operating

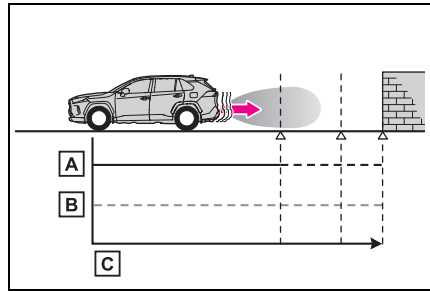

A Hybrid system output

B Braking force

C Time

- Figure 2: When hybrid system output restriction control operates

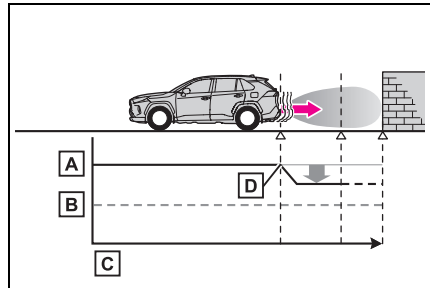

A Hybrid system output

B Braking force

C Time

D Hybrid system output restriction control begins operating (System determines that possibility of collision with detected object is high)

- Figure 3: When hybrid system output restriction control and brake control operates

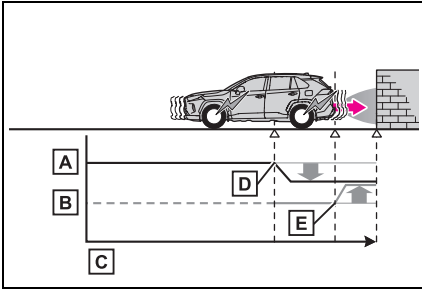

- A** Hybrid system output
- B** Braking force
- C** Time
- D** Hybrid system output restriction control begins operating (System determines that possibility of collision with detected object is high)
- E** Brake control begins operating (System determines that possibility of collision with detected object is extremely high)

#### ■ If the Parking Support Brake has operated

If the vehicle is stopped due to operation of the Parking Support Brake, the Parking Support Brake will be disabled and the PKSB OFF indicator will illuminate. If the Parking Support Brake operates unnecessarily, brake control can be canceled by depressing the brake pedal or waiting for approximately 2 seconds for it to automatically be canceled. Then, the vehicle can be operated by depressing the accelerator pedal.

#### ■ Re-enabling the Parking Support Brake

To re-enable the Parking Support Brake when it is disabled due to operation of the Parking Support Brake, either enable the system again (→P.270), or turn the power switch to OFF and then

back to ON. Additionally, if the object becomes no longer in the traveling direction of the vehicle or if the traveling direction of the vehicle changes (such as changing from moving forward to backing up, or from backing up to moving forward), the system will be re-enabled automatically.

#### ■ If “PKSB Unavailable” is displayed on the multi-information display and the PKSB OFF indicator is flashing

If this message is displayed, a sensor on the front or rear bumper may be dirty. Clean the sensors and their surrounding area on the bumpers.

#### ■ If “PKSB Unavailable” and “Parking Assist Unavailable Clean Parking Assist Sensor” are displayed on the multi-information display and the PKSB OFF indicator is flashing

- A sensor may be covered with ice, snow, dirt, etc. In this case, remove the ice, snow, dirt, etc., from the sensor to return the system to normal. If this message is shown even after removing dirt from the sensor, or shown when the sensor was not dirty to begin with, have the vehicle inspected at your Toyota dealer.
- A sensor may be frozen. Once the ice melts, the system will return to normal.
- Water may be continuously flowing over the sensor surface, such as in a heavy rain. When the system determines that it is normal, the system will return to normal.

#### ■ If a 12-volt battery terminal has been disconnected and reconnected

The system needs to be initialized. To initialize the system, drive the vehicle straight ahead for 5 seconds or more at a speed of approximately 35 km/h (22 mph) or more.

## Parking Support Brake function (static objects)\*

\*: If equipped

If the sensors detect a static object, such as a wall, in the traveling direction of the vehicle and the system determines that a collision may occur due to the vehicle suddenly moving forward due to an accidental accelerator pedal operation, the vehicle moving the unintended direction due to the wrong shift position being selected, or while parking or traveling at low speeds, the system will operate to lessen the impact with the detected static object and reduce the resulting damage.

### Examples of function operation

This function will operate in situations such as the following if an object is detected in the traveling direction of the vehicle.

- When traveling at a low speed and the brake pedal is not depressed, or is depressed late

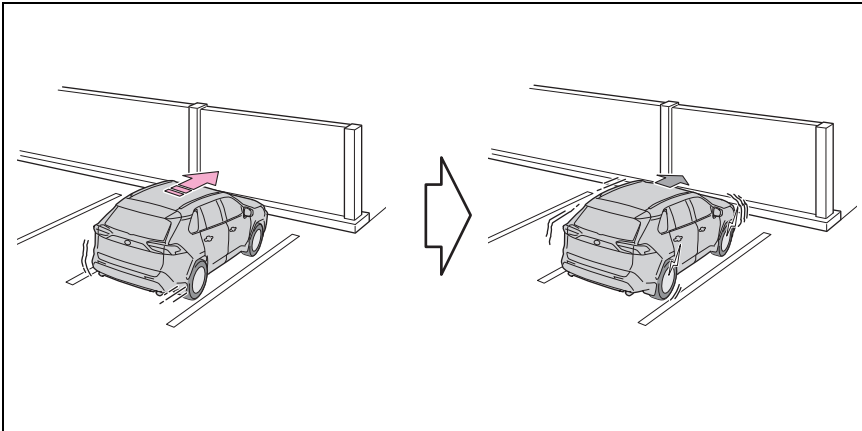

### ■ When the accelerator pedal is depressed excessively

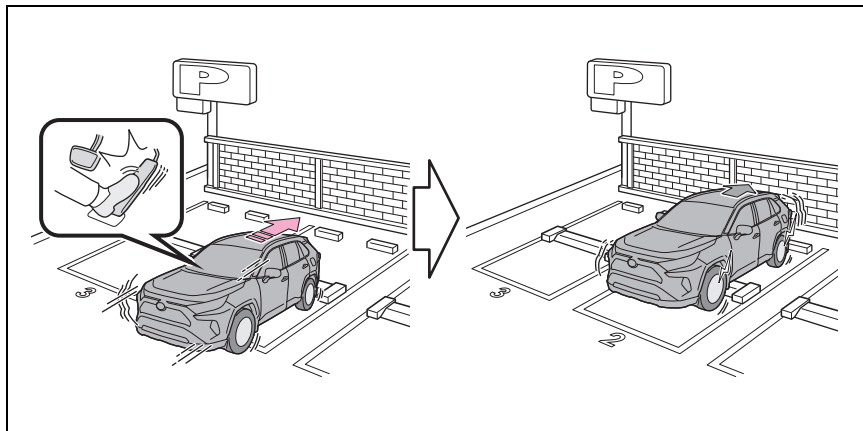

### ■ When the vehicle moves in the unintended direction due to the wrong shift position being selected

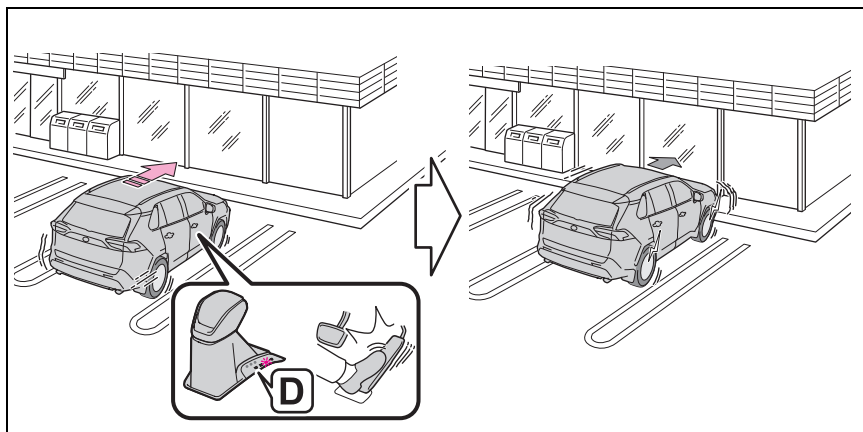

### Types of sensors

→P.253



#### WARNING

■ To ensure the system can operate properly

→P.255

■ If the Parking Support Brake function (static objects) operates unnecessarily, such as at a railroad crossing

→P.272

■ Notes when washing the vehicle

→P.255

### ■ The Parking Support Brake function (static object) will operate when

The function will operate when the PKSB OFF indicator is not illuminated or flashing (→P.74, 76) and all of the following conditions are met:

- Hybrid system output restriction control
- The Parking Support Brake is enabled.
- The vehicle speed is approximately 15 km/h (9 mph) or less.
- There is a static object in the traveling direction of the vehicle and approximately 2 to 4 m (6 to 13 ft.) away.
- The Parking Support Brake determines that a stronger-than-normal brake operation is necessary to avoid a collision.
- Brake control
- Hybrid system output restriction control is operating
- The Parking Support Brake determines that an immediate brake operation is necessary to avoid a collision.

### ■ The Parking Support Brake function (static objects) will stop operating when

The function will stop operating if any of the following conditions are met:

- Hybrid system output restriction control
- The Parking Support Brake is disabled.
- The system determines that the collision has become avoidable with normal brake operation.
- The static object is no longer approximately 2 to 4 m (6 to 13 ft.) away from the vehicle or in the traveling direction of the vehicle.
- Brake control
- The Parking Support Brake is disabled.
- Approximately 2 seconds have elapsed since the vehicle was stopped by brake control.
- The brake pedal is depressed after

the vehicle is stopped by brake control.

- The static object is no longer approximately 2 to 4 m (6 to 13 ft.) away from the vehicle or in the traveling direction of the vehicle.

### ■ Detection range of the Parking Support Brake function (static objects)

The detection range of the Parking Support Brake function (static objects) differs from the detection range of the Toyota parking assist-sensor. (→P.258) Therefore, even if the Toyota parking assist-sensor detects an object and provides a warning, the Parking Support Brake function (static objects) may not start operating.

### ■ Situations in which the Parking Support Brake function (static objects) may not operate

When the shift lever is in N

### ■ Situations in which the system may not operate properly

→P.256

### ■ Situations in which the system may operate even if there is no possibility of a collision

→P.257

## Parking Support Brake function (rear-crossing vehicles)\*

\*: If equipped

If a rear radar sensor detects a vehicle approaching from the right or left at the rear of the vehicle and the system determines that the possibility of a collision is high, this function will perform brake control to reduce the likelihood of an impact with the approaching vehicle.

### Examples of function operation

This function will operate in situations such as the following if a vehicle is detected in the traveling direction of the vehicle.

- When reversing, a vehicle is approaching and the brake pedal is not depressed, or is depressed late

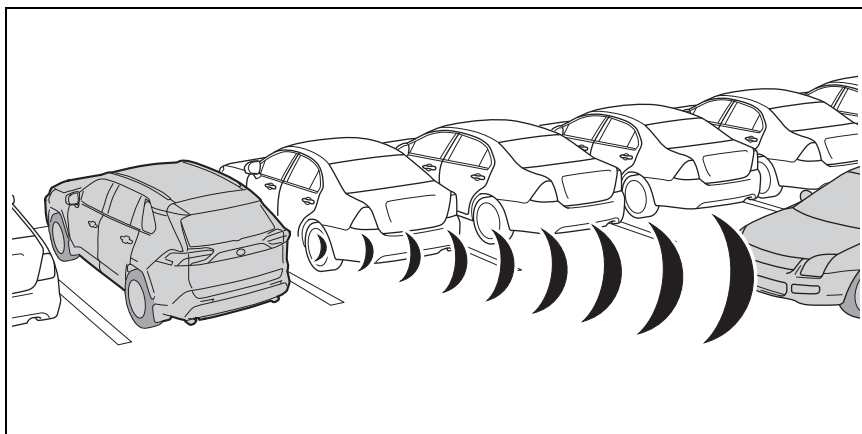

### Types of sensors

→P.250



#### WARNING

- To ensure the system can operate properly

→P.250

- The Parking Support Brake function (rear-crossing vehicles) will operate when

The function will operate when the PKSB OFF indicator is not illuminated or flashing (→P.74, 76) and all of the following conditions are met:

- Hybrid system output restriction control
- The Parking Support Brake is

enabled.

- The vehicle speed is approximately 15 km/h (9 mph) or less.
- Vehicles are approaching from the right or left at the rear of the vehicle at a traveling speed of approximately 8 km/h (5 mph) or more.
- The shift lever is in R.
- The Parking Support Brake determines that a stronger than normal brake operation is necessary to avoid a collision with an approaching vehicle.
- Brake control
- Hybrid system output restriction control is operating
- The Parking Support Brake determines that an emergency brake operation is necessary to avoid a collision with an approaching vehicle.

■ **The Parking Support Brake function (rear-crossing vehicles) will stop operating when**

The function will stop operating if any of the following conditions are met:

- Hybrid system output restriction control
- The Parking Support Brake is disabled.
- The collision becomes avoidable with normal brake operation.
- A vehicle is no longer approaching from the right or left at the rear of the vehicle.
- Brake control
- The Parking Support Brake is disabled.
- Approximately 2 seconds have elapsed since the vehicle was stopped by brake control.
- The brake pedal is depressed after the vehicle is stopped by brake control.
- A vehicle is no longer approaching from the right or left at the rear of the vehicle.

■ **Detection area of the Parking Support Brake function (rear-crossing vehicles)**

The detection area of the Parking Sup-

port Brake function (rear-crossing vehicles) differs from the detection area of the RCTA function (→P.264). Therefore, even if the RCTA function detects a vehicle and provides an alert, the Parking Support Brake function (rear-crossing vehicles) may not start operating.

■ **Situations in which the system may not operate properly**

→P.266

■ **Situations in which the system may operate even if there is no possibility of a collision**

→P.267

## Driving mode select switch

The driving modes can be selected to suit the driving and usage conditions.

### Selecting a driving mode

#### ■ FF vehicles

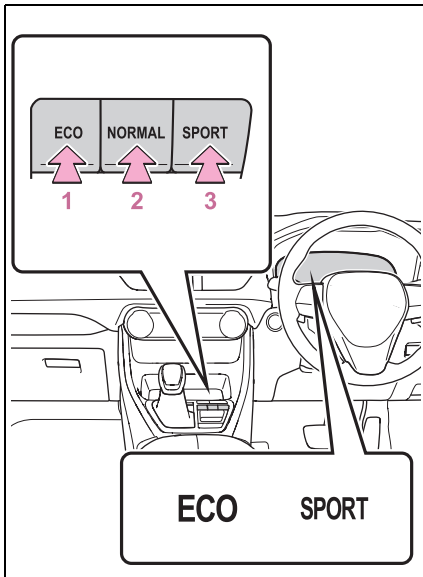

#### 1 Eco drive mode

Suitable for driving to improve fuel economy by more smoothly generating torque in response to accelerator pedal operations compared to normal mode and restraining air conditioning system operations (heating/cooling).

When the switch is pressed while not in Eco drive mode, the system switches to Eco drive mode and the Eco drive mode indicator illuminates on the multi-information display.

#### 2 Normal mode

Suitable for normal driving.

The driving mode returns to normal mode if the switch is pressed while in Eco drive mode or sport mode.

#### 3 Sport mode

Controls the steering feeling and hybrid system to create an acceleration response that is suitable for sporty driving. Suitable for when crisp handling is desired, such as when driving on mountainous roads.

When the switch is pressed while not in sport mode, the system switches to sport mode and the sport mode indicator illuminates on the multi-information display.

#### ■ AWD vehicles

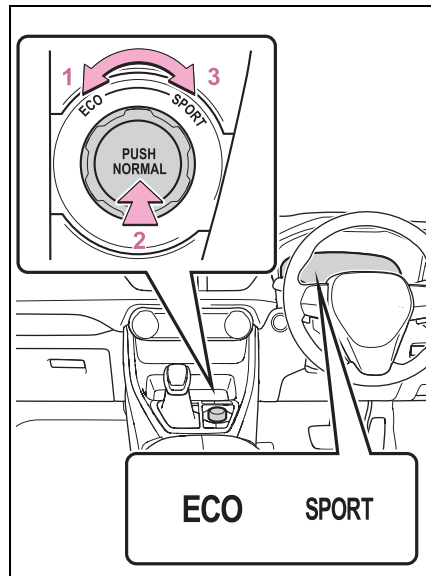

#### 1 Eco drive mode

Suitable for driving to improve fuel economy by more smoothly generating torque in response to accelerator pedal operations compared to normal mode and restraining air conditioning system operations (heating/cooling).



When the switch is turned to the left while not in Eco drive mode, the system switches to Eco drive mode and the Eco drive mode indicator illuminates on the multi-information display.

## 2 Normal mode

Suitable for normal driving.

The driving mode returns to normal mode if the switch is pressed while in Eco drive mode or sport mode.

## 3 Sport mode

Controls the steering feeling and hybrid system to create an acceleration response that is suitable for sporty driving. Suitable for when crisp handling is desired, such as when driving on mountainous roads.

When the switch is turned to the right while not in sport mode, the system switches to sport mode and the sport mode indicator illuminates on the multi-information display.

### ■ When the driving mode is changed

- The background color of the multi-information display changes according to the selected driving mode.
- When the speedometer is set to analog display, the speedometer display color also changes. (For vehicles with 7-inch multi-information display only)
- The color of the switch changes according to the selected driving mode. (AWD models with 12.3-inch multi-information display)

### ■ Air conditioning system operation in Eco drive mode

In Eco drive mode, heating/cooling operations and the fan speed is controlled to improve fuel efficiency. Perform the following procedures to increase the air conditioning performance.

- Adjust the fan speed (→P.299)
  - Cancel Eco drive mode
- ### ■ Canceling a driving mode
- Sport mode is automatically canceled and the driving mode returns to normal mode when the power switch is turned off.
  - Normal mode and Eco drive mode are not canceled until another driving mode is selected. (Even if the power switch is turned off, normal mode and Eco drive mode will not be automatically canceled).
- Turn eco air conditioning mode off (→P.300)

## Trail Mode (AWD vehicles)

Trail Mode is designed to control the spinning of the drive wheels by integratedly controlling AWD, brake and drive force control systems. Use the Trail Mode when driving bumpy roads, etc.



### WARNING

#### ■ Before using Trail Mode

Make sure to observe the following precautions. Failure to observe these precautions may result in an unexpected accident.

- Trail mode is intended for use when driving on rough roads.
- Check that the Trail Mode indicator is illuminated before driving.
- Trail Mode is not intended to expand the limits of the vehicle. Thoroughly check the road conditions and drive with caution.

## Enabling the system

Press the Trail Mode switch.

Press the Trail Mode switch, to turn the Trail Mode on.

The Trail Mode indicator light will come on the multi-information display.

To turn the system off, press the Trail Mode switch again.

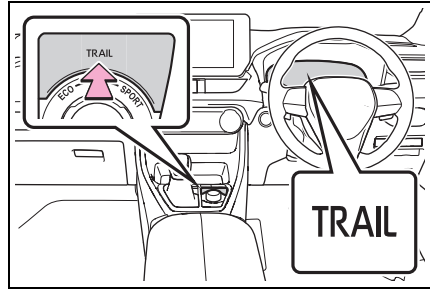

## When the Trail Mode is operating

If the tires are spinning, the slip indicator flashes to indicate that the Trail Mode is controlling the spinning of the tires.

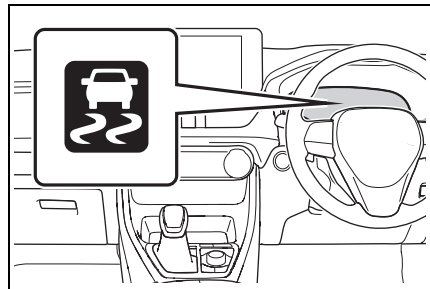

### ■ Trail Mode

- Trail Mode controls the vehicle so that it can use the maximum amount of drive force when driving on rough roads. As a result, fuel efficiency may diminish when compared to driving with Trail Mode off.
- If Trail Mode is continuously used for a long period of time, depending on the driving conditions, the load on related parts increases and the system may not function correctly.

In this case, "Traction Control Turned OFF" will be shown on the multi-information display but the vehicle can be driven normally.

The “Traction Control Turned OFF” on the multi-information display will turn off after a short while and the system will operate properly.

#### ■ When Trail Mode is canceled

In the following situations, Trail Mode is automatically canceled even if it is selected:

- When the driving mode is changed. (→P.278)
- When the hybrid system is restarted.

#### ■ Sounds and vibrations when driving in Trail Mode

Any of the following conditions may occur when Trail Mode is operating. None of these indicates that a malfunction has occurred:

- Vibrations may be felt throughout the vehicle or steering wheel
- Sounds may be heard from the engine compartment

#### ■ When the Trail Mode indicator does not illuminate

When the Trail Mode indicator does not illuminate even though the Trail Mode switch is pressed, the system may be malfunctioning.

Have the vehicle inspected by your Toyota dealer immediately.



#### NOTICE

#### ■ In order to ensure that Trail Mode operates properly

Do not continuously use the Trail Mode for a long period of time. Depending on the driving conditions, the load on related parts increases and the system may not operate properly.

## Driving assist systems

**To keep driving safety and performance, the following systems operate automatically in response to various driving situations. Be aware, however, that these systems are supplementary and should not be relied upon too heavily when operating the vehicle.**

### Summary of the driving assist systems

#### ■ ECB (Electronically Controlled Brake System)

The electronically controlled system generates braking force corresponding to the brake operation

#### ■ ABS (Anti-lock Brake System)

Helps to prevent wheel lock when the brakes are applied suddenly, or if the brakes are applied while driving on a slippery road surface

#### ■ Brake assist

Generates an increased level of braking force after the brake pedal is depressed when the system detects a panic stop situation

#### ■ VSC (Vehicle Stability Control)

Helps the driver to control skidding when swerving suddenly or turning on slippery road surfaces.

Provides cooperative control of the ABS, TRC, VSC and EPS.

Helps to maintain directional stability when swerving on slippery road surfaces by controlling steering performance.

#### ■ Trailer Sway Control

Helps the driver to control trailer sway by selectively applying brake pressure for individual wheels and reducing driving torque when trailer sway is detected.

#### ■ TRC (Traction Control)

Helps to maintain drive power and prevent the drive wheels from spinning when starting the vehicle or accelerating on slippery roads

#### ■ Active Cornering Assist (ACA)

Helps to prevent the vehicle from drifting to the outer side by performing inner wheel brake control when attempting to accelerate while turning

#### ■ Hill-start assist control

Helps to reduce the backward movement of the vehicle when starting on an uphill

#### ■ EPS (Electric Power Steering)

Employs an electric motor to reduce the amount of effort needed to turn the steering wheel.

#### ■ E-Four (Electronic On-Demand AWD system) (AWD models)

Automatically controls the drive system such as to front-wheel drive or AWD (all wheel drive) according to various running conditions including normal driving, during cor-

nering, on a uphill, when starting off, during acceleration, on a slippery roads due to snow or rain, thus contributing to stable operability and driving stability.

#### ■ Emergency brake signal

When the brakes are applied suddenly, the emergency flashers automatically flash to alert the vehicle behind.

#### ■ The Secondary Collision Brake (if equipped)

When the SRS airbag sensor detects a collision and the system operates, the brakes and brake lights are automatically controlled to reduce the vehicle speed and help reduce the possibility of further damage due to a secondary collision.

---

#### ■ When the TRC/VSC/ABS/Trail Mode/Trailer Sway Control systems are operating

The slip indicator light will flash while the TRC/VSC/ABS/Trail Mode/Trailer Sway Control systems are operating.

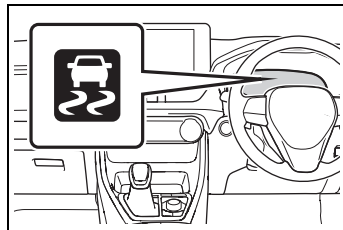

#### ■ Disabling the TRC system

If the vehicle gets stuck in mud, dirt or snow, the TRC system may reduce power from the hybrid system to the wheels.

Pressing  to turn the system off may

make it easier for you to rock the vehicle in order to free it.

To turn the TRC system off, quickly press and release .

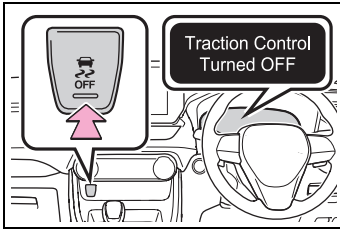

The “Traction Control Turned OFF” will be shown on the multi-information display.

Press  again to turn the system back on.

#### ■ Turning off the TRC/VSC/Trailer Sway Control systems

To turn the TRC/VSC/Trailer Sway Control systems off, press and hold  for more than 3 seconds while the vehicle is stopped.

The VSC OFF indicator light will come on and the “Traction Control Turned OFF” will be shown on the multi-information display.\*

Press  again to turn the systems back on.

\*: On vehicles with PCS (Pre-Collision System), PCS will also be disabled (only pre-collision warning is available). The PCS warning light will come on and a message will be displayed on the multi-information display. (→P.220)

- **When the message is displayed on the multi-information display showing that TRC has been disabled even if  has not been pressed**

TRC is temporary deactivated. If the information continues to show, contact your Toyota dealer.

#### ■ Operating conditions of hill-start assist control

When all of the following conditions are met, the hill-start assist control will operate:

- The shift lever is in a position other than P or N (when starting off forward/backward on an upward incline)
- The vehicle is stopped
- The accelerator pedal is not depressed
- The parking brake is not engaged
- The power switch is in ON

#### ■ Automatic system cancelation of hill-start assist control

The hill-start assist control will turn off in any of the following situations:

- The shift lever is shifted to P or N
- The accelerator pedal is depressed
- The brake pedal is depressed and the parking brake is engaged
- A maximum of 2 seconds have elapsed after the brake pedal is released
- The power switch is turned to OFF

#### ■ Sounds and vibrations caused by the ABS, brake assist, VSC, Trailer Sway Control, TRC and hill-start assist control systems

- A sound may be heard from the engine compartment when the brake pedal is depressed repeatedly, when the hybrid system is started or just after the vehicle begins to move. This sound does not indicate that a malfunction has occurred in any of these systems.

- Any of the following conditions may occur when the above systems are operating. None of these indicates that a malfunction has occurred.
- Vibrations may be felt through the vehicle body and steering.
- A motor sound may be heard also after the vehicle comes to a stop.

#### ■ ECB operating sound

ECB operating sound may be heard in the following cases, but it does not indicate that a malfunction has occurred.

- Operating sound heard from the engine compartment when the brake pedal is operated.
- Motor sound of the brake system heard from the front part of the vehicle when the driver's door is opened.
- Operating sound heard from the engine compartment when one or two minutes passed after the stop of the hybrid system.

#### ■ Active Cornering Assist operation sounds and vibrations

When the Active Cornering Assist is operated, operation sounds and vibrations may be generated from the brake system, but this is not a malfunction.

#### ■ Automatic reactivation of TRC, Trailer Sway Control and VSC systems

After turning the TRC, Trailer Sway Control and VSC systems off, the systems will be automatically re-enabled in the following situations:

- When the power switch is turned off
- If only the TRC system is turned off, the TRC will turn on when vehicle speed increases  
If both the TRC and VSC systems are turned off, automatic re-enabling will not occur when vehicle speed increases.

#### ■ Operating conditions of Active Cornering Assist

The system operates when the following occurs.

- TRC/VSC can operate
- The driver is attempting to accelerate while turning
- The system detects that the vehicle is drifting to the outer side
- The brake pedal is released

#### ■ Reduced effectiveness of the EPS system

The effectiveness of the EPS system is reduced to prevent the system from overheating when there is frequent steering input over an extended period of time. The steering wheel may feel heavy as a result. Should this occur, refrain from excessive steering input or stop the vehicle and turn the hybrid system off. The EPS system should return to normal within 10 minutes.

#### ■ Operating conditions of emergency brake signal

When the following conditions are met, the emergency brake signal will operate:

- The emergency flashers are off.
- Actual vehicle speed is over 55 km/h (35 mph).
- The system judges from the vehicle deceleration that it is a sudden braking operation.

#### ■ Automatic system cancelation of emergency brake signal

The emergency brake signal will be canceled in any of the following situations:

- The emergency flashers are turned on
- The system judges from the vehicle deceleration that is not a sudden braking operation

#### ■ Secondary Collision Brake operating conditions (if equipped)

The system operates when the SRS airbag sensor detects a collision while the vehicle is in motion.

However, the system does not operate when the components are damaged.

### ■ Secondary Collision Brake automatic cancellation (if equipped)

The system is automatically canceled in any of the following situations.

- The vehicle speed is below 10 km/h (6 mph)
- A certain amount of time elapses during operation
- The accelerator pedal is depressed a large amount

### ■ If a message about AWD is shown on the multi-information display (AWD models)

Perform the following actions.

- “AWD System Overheated Switching to 2WD Mode”/“4WD System Overheated Switching to 2WD Mode”

AWD system is overheated. Stop the vehicle in a safe place with the hybrid system operating.\*

If the message disappears after a while, there is no problem. If the message remains, have the vehicle inspected by your Toyota dealer immediately.

- “AWD System Overheated 2WD Mode Engaged”/“4WD System Overheated 2WD Mode Engaged”

AWD system has been temporarily released and switched to front-wheel drive due to overheating. Stop the vehicle in a safe place with the hybrid system operating.\*

If the message disappears after a while, AWD system will automatically recover. If the message remains, have the vehicle inspected by your Toyota dealer immediately.

- “AWD System Malfunction 2WD Mode Engaged Visit Your Dealer”/“4WD System Malfunction 2WD Mode Engaged Visit Your Dealer”

A malfunction occurs in the AWD system. Have the vehicle inspected by your

Toyota dealer immediately.

\*: When stopping the vehicle, do not stop the hybrid system until the display message has turned off.

### WARNING

#### ■ The ABS does not operate effectively when

- The limits of tire gripping performance have been exceeded (such as excessively worn tires on a snow covered road).
- The vehicle hydroplanes while driving at high speed on wet or slick roads.

#### ■ Stopping distance when the ABS is operating may exceed that of normal conditions

The ABS is not designed to shorten the vehicle's stopping distance. Always maintain a safe distance from the vehicle in front of you, especially in the following situations:

- When driving on dirt, gravel or snow-covered roads
- When driving with tire chains
- When driving over bumps in the road
- When driving over roads with potholes or uneven surfaces

#### ■ TRC/VSC may not operate effectively when

Directional control and power may not be achievable while driving on slippery road surfaces, even if the TRC/VSC system is operating. Drive the vehicle carefully in conditions where stability and power may be lost.



## WARNING

### ■ Active Cornering Assist does not operate effectively when

- Do not overly rely on Active Cornering Assist. Active Cornering Assist may not operate effectively when accelerating down slopes or driving on slippery road surfaces.
- When Active Cornering Assist frequently operates, Active Cornering Assist may temporarily stop operating to ensure proper operation of the brakes, TRC and VSC.

### ■ Hill-start assist control does not operate effectively when

- Do not overly rely on hill-start assist control. Hill-start assist control may not operate effectively on steep inclines and roads covered with ice.
- Unlike the parking brake, hill-start assist control is not intended to hold the vehicle stationary for an extended period of time. Do not attempt to use hill-start assist control to hold the vehicle on an incline, as doing so may lead to an accident.

### ■ When the TRC/ABS/VSC/Trailer Sway Control is activated

The slip indicator light flashes. Always drive carefully. Reckless driving may cause an accident. Exercise particular care when the indicator light flashes.

### ■ When the TRC/VSC/Trailer Sway Control systems are turned off

Be especially careful and drive at a speed appropriate to the road conditions. As these are the systems to help ensure vehicle stability and driving force, do not turn the TRC/VSC/Trailer Sway Control systems off unless necessary.

Trailer Sway Control is part of the VSC system and will not operate if VSC is turned off or experiences a malfunction.

### ■ Replacing tires

Make sure that all tires are of the specified size, brand, tread pattern and total load capacity. In addition, make sure that the tires are inflated to the recommended tire inflation pressure level.

The ABS, TRC, VSC and Trailer Sway Control systems will not function correctly if different tires are installed on the vehicle.

Contact your Toyota dealer for further information when replacing tires or wheels.

### ■ Handling of tires and the suspension

Using tires with any kind of problem or modifying the suspension will affect the driving assist systems, and may cause a system to malfunction.

### ■ Trailer Sway Control precaution

The Trailer Sway Control system is not able to reduce trailer sway in all situations. Depending on many factors such as the conditions of the vehicle, trailer, road surface and driving environment, the Trailer Sway Control system may not be effective. Refer to your trailer owner's manual for information on how to tow your trailer properly.

### ■ If trailer sway occurs

Observe the following precautions. Failing to do so may cause death or serious injury.

- Firmly grip the steering wheel. Steer straight ahead. Do not try to control trailer swaying by turning the steering wheel.



**WARNING**

- Begin releasing the accelerator pedal immediately but very gradually to reduce speed. Do not increase speed. Do not apply vehicle brakes.

If you make no extreme correction with the steering or brakes, your vehicle and trailer should stabilize.

(→P.170)

- **Secondary Collision Brake (if equipped)**

Do not rely solely upon the Secondary Collision Brake. This system is designed to help reduce the possibility of further damage due to a secondary collision, however, that effect changes according to various conditions. Overly relying on the system may result in death or serious injury.

## Hybrid Electric Vehicle driving tips

For economical and ecological driving, pay attention to the following points:

### Using Eco drive mode

When using Eco drive mode, the torque corresponding to the accelerator pedal depression amount can be generated more smoothly than it is in normal conditions. In addition, the operation of the air conditioning system (heating/cooling) will be minimized, improving the fuel economy. (→P.278)

### Use of Hybrid System Indicator

The Eco-friendly driving is possible by keeping the indicator of Hybrid System Indicator within Eco area. (→P.81, 86)

### Shift lever operation

Shift the shift lever to D when stopped at a traffic light, or driving in heavy traffic etc. Shift the shift lever to P when parking. When using the N position, there is no positive effect on fuel consumption. In the N position, the gasoline engine operates but electricity cannot be generated. Also, when using the air conditioning system, etc.,

the hybrid battery (traction battery) power is consumed.

### Accelerator pedal/brake pedal operation

- Drive your vehicle smoothly. Avoid abrupt acceleration and deceleration. Gradual acceleration and deceleration will make more effective use of the electric motor (traction motor) without having to use gasoline engine power.
- Avoid repeated acceleration. Repeated acceleration consumes hybrid battery (traction battery) power, resulting in poor fuel consumption. Battery power can be restored by driving with the accelerator pedal slightly released.

### When braking

Make sure to operate the brakes gently and in a timely manner. A greater amount of electrical energy can be regenerated when slowing down.

### Delays

Repeated acceleration and deceleration, as well as long waits at traffic lights, will lead to bad fuel economy. Check traffic reports before leaving and avoid delays as much as possible. When driving in

a traffic jam, gently release the brake pedal to allow the vehicle to move forward slightly while avoiding overuse of the accelerator pedal. Doing so can help control excessive gasoline consumption.

### Highway driving

Control and maintain the vehicle at a constant speed. Before stopping at a toll booth or similar, allow plenty of time to release the accelerator and gently apply the brakes. A greater amount of electrical energy can be regenerated when slowing down.

### Air conditioning

Use the air conditioning only when necessary. Doing so can help reduce excessive gasoline consumption.

In summer: When the ambient temperature is high, use the recirculated air mode. Doing so will help to reduce the burden on the air conditioning system and reduce fuel consumption as well.

In winter: Because the gasoline engine will not automatically cut out until it and the interior of the vehicle are warm, it will consume fuel. Also, fuel consumption can be improved by avoiding overuse of the heater.

### Checking tire inflation pressure

Make sure to check the tire inflation pressure frequently. Improper tire inflation pressure can cause poor fuel economy.

Also, as snow tires can cause large amounts of friction, their use on dry roads can lead to poor fuel economy. Use tires that are appropriate for the season.

### Luggage

Carrying heavy luggage will lead to poor fuel economy. Avoid carrying unnecessary luggage. Installing a large roof rack will also cause poor fuel economy.

### Warming up before driving

Since the gasoline engine starts up and cuts out automatically when cold, warming up the engine is unnecessary. Moreover, frequently driving short distances will cause the engine to repeatedly warm up, which can lead to excess fuel consumption.

## Winter driving tips

**Carry out the necessary preparations and inspections before driving the vehicle in winter. Always drive the vehicle in a manner appropriate to the prevailing weather conditions.**

### Pre-winter preparations

- Use fluids that are appropriate to the prevailing outside temperatures.
  - Engine oil
  - Engine coolant
  - Power control unit coolant
  - Washer fluid
- Have a service technician inspect the condition of the 12-volt battery.
- Have the vehicle fitted with four snow tires or purchase a set of tire chains for the front tires.\*

Ensure that all tires are the same size and brand, and that chains match the size of the tires.

\*: Tire chains cannot be mounted on vehicles with 235/55R19 tires.



#### WARNING

##### ■ Driving with snow tires

Observe the following precautions to reduce the risk of accidents. Failure to do so may result in a loss of vehicle control and cause death or serious injury.

- Use tires of the specified size.

- Maintain the recommended level of air pressure.

- Do not drive at speeds in excess of the speed limit or the speed limit specified for the snow tires being used.

- Use snow tires on all, not just some wheels.

##### ■ Driving with tire chains (except 235/55R19 tires)

Observe the following precautions to reduce the risk of accidents.

Failure to do so may result in the vehicle being unable to be driven safely, and may cause death or serious injury.

- Do not drive in excess of the speed limit specified for the tire chains being used, or 50 km/h (30 mph), whichever is lower.

- Avoid driving on bumpy road surfaces or over potholes.

- Avoid sudden acceleration, abrupt steering, sudden braking and shifting operations that cause sudden engine braking.

- Slow down sufficiently before entering a curve to ensure that vehicle control is maintained.

- Do not use LTA (Lane Tracing Assist) system (if equipped).

## Before driving the vehicle

Perform the following according to the driving conditions:

- Do not try to forcibly open a window or move a wiper that is frozen. Pour warm water over the frozen area to melt the ice. Wipe away the water immediately to prevent it from freezing.

- To ensure proper operation of the climate control system fan, remove any snow that has accumulated on the air inlet vents in front of the windshield.
- Check for and remove any excess ice or snow that may have accumulated on the exterior lights, outside rear view mirrors, windows, vehicle's roof, chassis, around the tires or on the brakes.
- Remove any snow or mud from the bottom of your shoes before getting in the vehicle.

### When driving the vehicle

Accelerate the vehicle slowly, keep a safe distance between you and the vehicle ahead, and drive at a reduced speed suitable to road conditions.

### When parking the vehicle

- Turn automatic mode of the parking brake off. Otherwise, the parking brake may freeze and not be able to be released automatically.

Also, avoid using the following as the parking brake may operate automatically, even if automatic mode is off.

- Brake hold system
- Park the vehicle and shift the shift lever to P without setting the parking brake. The parking brake may freeze up, preventing it from

being released. If the vehicle is parked without setting the parking brake, make sure to block the wheels. Failure to do so may be dangerous because it may cause the vehicle to move unexpectedly, possibly leading to an accident.

- When the parking brake is in automatic mode, release the parking brake after shifting the shift lever to P. (→P.188)
- If the vehicle is parked without setting the parking brake, confirm that the shift lever cannot be moved out of P.
- If the vehicle is left parked with the brakes damp in cold temperatures, there is a possibility of the brakes freezing.



### WARNING

#### ■ When parking the vehicle

When parking the vehicle without applying the parking brake, make sure to chock the wheels. If you do not chock the wheels, the vehicle may move unexpectedly, possibly resulting in an accident.

### Selecting tire chains

- ▶ Vehicles without 235/55R19 tires
- Use the correct tire chain size when mounting the tire chains. Chain size is regulated for each tire size.

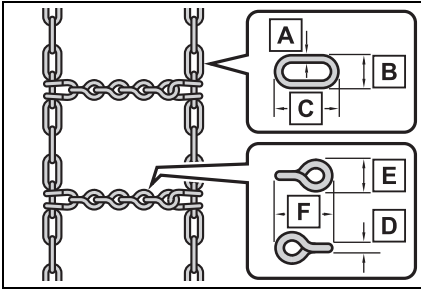

Side chain:

**A** 3 mm (0.12 in.) in diameter

**B** 10 mm (0.39 in.) in width

**C** 30 mm (1.18 in.) in length

Cross chain:

**D** 4 mm (0.16 in.) in diameter

**E** 14 mm (0.55 in.) in width

**F** 25 mm (0.98 in.) in length

► Vehicles with 235/55R19 tires

Tire chains cannot be mounted.

Snow tires should be used instead.

### Regulations on the use of tire chains (except 235/55R19 tires)

Regulations regarding the use of tire chains vary depending on location and type of road. Always check local regulations before installing chains.

#### ■ Tire chain installation

Observe the following precautions when installing and removing chains:

- Install and remove tire chains in a safe location.
- Install tire chains on the front tires

only. Do not install tire chains on the rear tires.

- Install tire chains on front tires as tightly as possible. Retighten chains after driving 0.5 - 1.0 km (1/4 - 1/2 mile).
- Install tire chains following the instructions provided with the tire chains.

## Utility vehicle precautions

**This vehicle belongs to the utility vehicle class, which has higher ground clearance and narrower tread in relation to the height of its center of gravity to make it capable of performing in a wide variety of off-road applications.**

### Utility vehicle feature

- Specific design characteristics give it a higher center of gravity than ordinary passenger cars. This vehicle design feature causes this type of vehicle to be more likely to rollover. And, utility vehicles have a significantly higher rollover rate than other types of vehicles.
- An advantage of the higher ground clearance is a better view of the road allowing you to anticipate problems.
- It is not designed for cornering at the same speeds as ordinary passenger cars any more than low-slung sports cars are designed to perform satisfactorily under off-road conditions. Therefore, sharp turns at excessive speeds may cause the vehicle to rollover.



### WARNING

#### ■ Utility vehicle precautions

Always observe the following precautions to minimize the risk of death, serious injury or damage to your vehicle:

- In a rollover crash, an unbelted person is significantly more likely to die than a person wearing a seat belt. Therefore, the driver and all passengers should always fasten their seat belts.
- Avoid sharp turns or abrupt maneuvers, if at all possible. Failure to operate this vehicle correctly may result in loss of control or vehicle rollover causing death or serious injury.
- Loading cargo on the roof luggage carrier (if equipped) will make the center of the vehicle gravity higher. Avoid high speeds, sudden starts, sharp turns, sudden braking or abrupt maneuvers, otherwise it may result in loss of control or vehicle rollover due to failure to operate this vehicle correctly.
- Always slow down in gusty crosswinds. Because of its profile and higher center of gravity, your vehicle is more sensitive to side winds than an ordinary passenger car. Slowing down will allow you to have better control.
- Do not drive horizontally across steep slopes. Driving straight up or straight down is preferred. Your vehicle (or any similar off-road vehicle) can tip over sideways much more easily than forward or backward.

### Off-road driving

When driving your vehicle off-road, please observe the following pre-

cautions to ensure your driving enjoyment and to help prevent the closure of areas to off-road vehicles:

- Drive your vehicle only in areas where off-road vehicles are permitted to travel.
- Respect private property. Get owner's permission before entering private property.
- Do not enter areas that are closed. Honor gates, barriers and signs that restrict travel.
- Stay on established roads. When conditions are wet, driving techniques should be changed or travel delayed to prevent damage to roads.



### WARNING

#### ■ Off-road driving precautions

Always observe the following precautions to minimize the risk of death, serious injury or damage to your vehicle:

- Drive carefully when off the road. Do not take unnecessary risks by driving in dangerous places.
- Do not grip the steering wheel spokes when driving off-road. A bad bump could jerk the wheel and injure your hands. Keep both hands and especially your thumbs on the outside of the rim.
- Always check your brakes for effectiveness immediately after driving in sand, mud, water or snow.

- After driving through tall grass, mud, rock, sand, rivers, etc., check that there is no grass, bush, paper, rags, stone, sand, etc. adhering or trapped on the underbody. Clear off any such matter from the underbody. If the vehicle is used with these materials trapped or adhering to the underbody, a breakdown or fire could occur.
- When driving off-road or in rugged terrain, do not drive at excessive speeds, jump, make sharp turns, strike objects, etc. This may cause loss of control or vehicle rollover causing death or serious injury. You are also risking expensive damage to your vehicle's suspension and chassis.



### NOTICE

#### ■ To prevent the water damage

Take all necessary safety measures to ensure that water damage to the hybrid battery (traction battery), hybrid system or other components does not occur.

- Water entering the engine compartment may cause severe damage to the hybrid system. Water entering the interior may cause the hybrid battery (traction battery) stowed under the rear seats to short circuit.
- Water entering the hybrid transmission will cause deterioration in transmission quality. The malfunction indicator may come on, and the vehicle may not be drivable.
- Water can wash the grease from wheel bearings, causing rusting and premature failure, and may also enter the hybrid transaxle case, reducing the gear oil's lubricating qualities.





## NOTICE

**■ When you drive through water**

If driving through water, such as when crossing shallow streams, first check the depth of the water and the bottom of the riverbed for firmness. Drive slowly and avoid deep water.

**■ Inspection after off-road driving**

- Sand and mud that has accumulated around brake discs may affect braking efficiency and may damage brake system components.
- Always perform a maintenance inspection after each day of off-road driving that has taken you through rough terrain, sand, mud, or water.



**5-1. Using the air conditioning system and defogger**

Automatic air conditioning system .....**298**

Seat heaters/Seat ventilators .....**304**

**5-2. Using the interior lights**

Interior lights list.....**306**

**5-3. Using the storage features**

List of storage features .....**308**

Luggage compartment features .....**312**

**5-4. Using the other interior features**

Other interior features.....**317**

## Automatic air conditioning system

Air outlets and fan speed are automatically adjusted according to the temperature setting.

### Air conditioning controls

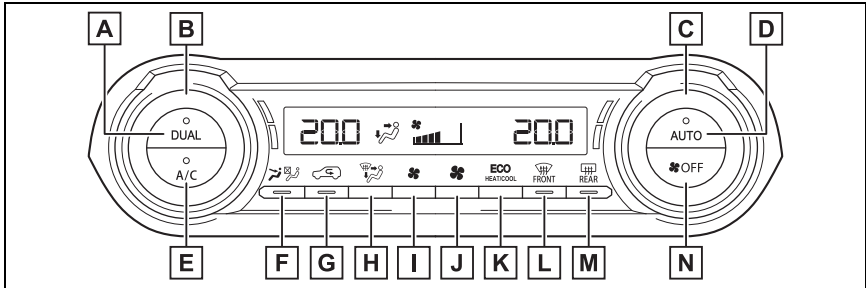

- A** “DUAL” switch
- B** Left-hand side temperature control switch
- C** Right-hand side temperature control switch
- D** Automatic mode switch
- E** “A/C” switch
- F** Front seat concentrated airflow mode (S-FLOW) switch
- G** Outside/recirculated air mode switch
- H** Airflow mode control switch
- I** Fan speed decrease switch
- J** Fan speed increase switch
- K** Eco air conditioning mode switch
- L** Windshield defogger switch
- M** Rear window and outside rear view mirror defoggers switch
- N** “OFF” switch

### ■ Adjusting the temperature setting

Turn driver's side temperature control dial clockwise to increase the temperature and turn the dial counterclockwise to decrease the temperature.

The air conditioning system switches between individual and simultaneous modes each time the "DUAL" switch is pressed.

Simultaneous mode (the indicator on the "DUAL" switch is off):

The driver's side temperature control dial can be used to adjust the temperature for the driver's and passenger's side. At this time, operate the passenger's side temperature control dial to enter individual mode.

Individual mode (the indicator on the "DUAL" switch is on):

The temperature for the driver's and passenger's side can be adjusted separately.

### ■ Setting the fan speed

Press the fan speed increase switch to increase the fan speed and the fan speed decrease switch to decrease the fan speed.

Pressing the "OFF" switch turns off the fan.

### ■ Change the airflow mode

Press the airflow mode control switch.

The airflow mode changes as follows each time the switch is pressed.

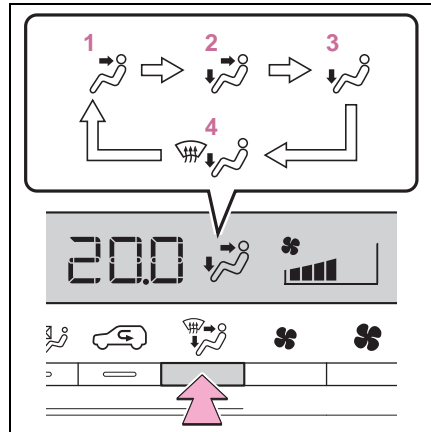

- 1 Upper body
- 2 Upper body and feet
- 3 Feet
- 4 Feet and the windshield defogger operates

### ■ Switching between outside air and recirculated air modes

Press the outside/recirculated air mode switch.

The mode switches between outside air mode and recirculated air mode each time the switch is operated.

When recirculated air mode is selected, the indicator illuminates on the outside/recirculated air mode switch.

### ■ Set cooling and dehumidification function

Press the "A/C" switch.

When the function is on, the indicator illuminates on the "A/C" switch.

### ■ Defogging the windshield

Defoggers are used to defog the windshield and front side windows.

Press the windshield defogger

switch.

Set the outside/recirculated air mode switch to outside air mode if the recirculated air mode is used. (It may switch automatically.)

To defog the windshield and the side windows quickly, turn the air flow and temperature up.

To return to the previous mode, press the windshield defogger switch again when the windshield is defogged.

When the windshield defogger switch is on, the indicator illuminates on the windshield defogger switch.

### ■ Defogging the rear window and outside rear view mirrors

Defoggers are used to defog the rear window, and to remove raindrops, dew and frost from the outside rear view mirrors.

Press the rear window and outside rear view mirror defoggers switch.

The defoggers will automatically turn off after 15 minutes.

When the rear window and outside rear view mirror defoggers switch is on, the indicator illuminates on the rear window and outside rear view mirror defoggers switch.

### ■ Eco air conditioning mode

The air conditioning is controlled with low fuel consumption prioritized such as reducing fan speed, etc.

Press the eco air conditioning mode switch.

When the eco air conditioning mode is on, the indicator illuminates on the eco

air conditioning mode switch.

### ■ Fogging up of the windows

- The windows will easily fog up when the humidity in the vehicle is high. Turning "A/C" switch on will dehumidify the air from the outlets and defog the windshield effectively.
- If you turn "A/C" switch off, the windows may fog up more easily.
- The windows may fog up if the recirculated air mode is used.

### ■ When driving on dusty roads

Close all windows. If dust thrown up by the vehicle is still drawn into the vehicle after closing the windows, it is recommended that the air intake mode be set to outside air mode and the fan speed to any setting except off.

### ■ Outside/recirculated air mode

- Setting to the recirculated air mode temporarily is recommended in preventing dirty air from entering the vehicle interior and helping to cool the vehicle when the outside air temperature is high.
- Outside/recirculated air mode may automatically switch depending on the temperature setting or the inside temperature.

### ■ Operation of the air conditioning system in Eco drive mode

- In Eco drive mode, the air conditioning system is controlled as follows to prioritize fuel efficiency:
  - Engine speed and compressor operation controlled to restrict heating/cooling capacity
  - Fan speed restricted when automatic mode is selected
- To improve air conditioning performance, perform the following operations:
  - Adjust the fan speed
  - Turn off Eco drive mode (→P.278)
  - Turn off Eco air conditioning mode
- When the driving mode is set to Eco

driving mode, the fan speed setting mode will be changed to Eco air conditioning mode automatically. Even in this case, the fan speed control mode can be changed by pressing the Eco air conditioning switch.

#### ■ When the outside temperature falls to nearly 0°C (32°F)

The dehumidification function may not operate even when “A/C” switch is pressed.

#### ■ Ventilation and air conditioning odors

- To let fresh air in, set the air conditioning system to the outside air mode.
- During use, various odors from inside and outside the vehicle may enter into and accumulate in the air conditioning system. This may then cause odor to be emitted from the vents.
- To reduce potential odors from occurring:
  - It is recommended that the air conditioning system be set to outside air mode prior to turning the vehicle off.
  - The start timing of the blower may be delayed for a short period of time immediately after the air conditioning system is started in automatic mode.
- When parking, the system automatically switches to outside air mode to encourage better air circulation throughout the vehicle, helping to reduce odors that occur when starting the vehicle.

#### ■ Using the voice control system (if equipped)

Air conditioning system can be operated using the voice control system. For details regarding the voice control system, refer to the “Multimedia Owner’s Manual”.

#### ■ Air conditioning filter

→P.353

#### ■ Customization

Settings (e.g. A/C Auto switch operation) can be changed.

(Customizable features: →P.440)



#### WARNING

##### ■ To prevent the windshield from fogging up

Do not use the windshield defogger switch during cool air operation in extremely humid weather.

The difference between the temperature of the outside air and that of the windshield can cause the outer surface of the windshield to fog up, blocking your vision.

##### ■ When the outside rear view mirror defoggers are operating

Do not touch the rear view mirror surfaces when the outside rear view mirror defoggers are on.



#### NOTICE

##### ■ To prevent 12-volt battery discharge

Do not leave the air conditioning system on longer than necessary when the hybrid system is off.

### Using automatic mode

- 1 Press the “AUTO” switch.

The dehumidification function begins to operate. Air outlets and fan speed are automatically adjusted according to the temperature setting and humidity.

- 2 Adjust the temperature setting.

- 3 To stop the operation, press the “OFF” switch.

If the fan speed setting or air flow modes are operated, the automatic mode indicator goes off. However, automatic mode for functions other than that operated is maintained.

### ■ Using automatic mode

Fan speed is adjusted automatically according to the temperature setting and the ambient conditions.

Therefore, the fan may stop for a while until warm or cool air is ready to flow immediately after the automatic mode switch is pressed.

### Front seat concentrated airflow mode (S-FLOW)

This function automatically controls the air conditioning airflow so that priority is given to the front seats.

Unnecessary air conditioning is suppressed, contributing to increased fuel efficiency.

Front seat concentrated airflow mode operates in the following situations.

- No passengers are detected in the rear seats
- The windshield defogger is not operating

While operating,  illuminates.

### ■ Manually turning front seat concentrated airflow mode on/off

In front seat concentrated airflow mode, directing airflow to the front seats only and to all seats can be switched via switch operation.

When the mode has been switched manually, automatic airflow control stops operating.

Press  on the air conditioning

operation panel and switch the airflow.

- Indicator illuminated: Airflow to the front seats only
- Indicator off: Airflow to all the seats

### ■ Operation of automatic airflow control

- In order to maintain a comfortable interior, airflow may be directed to seats without passengers immediately after the hybrid system is started and at other times depending on the outside temperature.
- After the hybrid system is started, if passengers move around inside or enter/exit the vehicle, the system cannot accurately detect the presence of passengers and automatic airflow control will not operate.

### ■ Operation of manual airflow control

Even if the function is manually switched to directing airflow to only the front seats, when a rear seat is occupied, it may automatically direct airflow to all seats.

### ■ To return to automatic airflow control

- 1 With the indicator off, turn the power switch to OFF.
- 2 After 60 minutes or more elapse, turn the power switch to ON.

### Air outlet layout and operations

#### ■ Location of air outlets

The air outlets and air volume change according to the selected air flow mode.



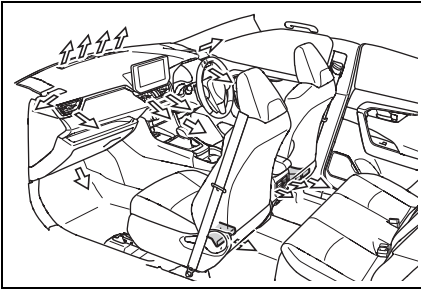

## ■ Adjusting the air flow direction and opening/closing the air outlets

### ► Front

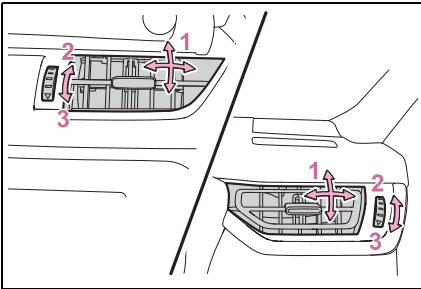

- 1 Direct air flow to the left or right, up or down
- 2 Open the vent\*
- 3 Close the vent\*

\*: If equipped (center air outlets only)

### ► Rear

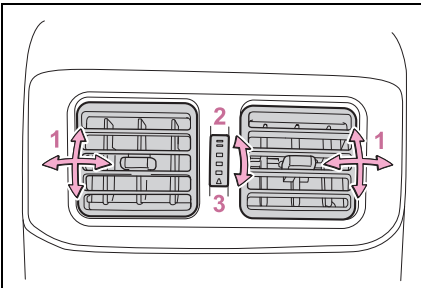

- 1 Direct air flow to the left or right, up or down

- 2 Open the vent
- 3 Close the vent

## ⚠ WARNING

### ■ To not interrupt the windshield defogger from operating

Do not place anything on the instrument panel which may cover the air outlets. Otherwise, air flow may be obstructed, preventing the windshield defoggers from defogging.

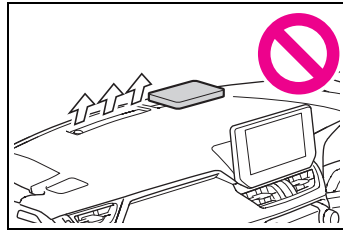

## Seat heaters<sup>\*</sup> / Seat ventilators<sup>\*</sup>

\*: If equipped

### ● Seat heaters

Warm up the seat upholstery

### ● Seat ventilators

Maintain good ventilation by pulling air through the seat upholstery



### WARNING

#### ■ To prevent minor burn injuries

Care should be taken if anyone in the following categories comes in contact with the seats when the heater is on:

- Babies, small children, the elderly, the sick and the physically challenged
- Persons with sensitive skin
- Persons who are fatigued
- Persons who have taken alcohol or drugs that induce sleep (sleeping drugs, cold remedies, etc.)



### NOTICE

#### ■ To prevent damage to the seat heaters and seat ventilators

Do not put heavy objects that have an uneven surface on the seat and do not stick sharp objects (needles, nails, etc.) into the seat.

#### ■ To prevent 12-volt battery discharge

Do not use the functions when the hybrid system is off.

## Operating the seat heaters

Turns the seat heaters on/off

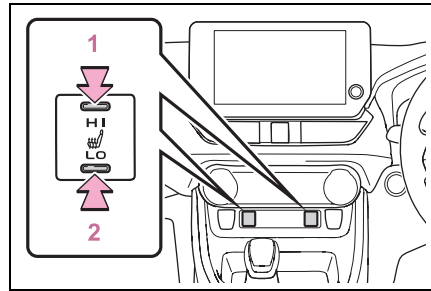

1 High temperature

2 Low temperature

When the seat heater is on, the indicator illuminates on the seat heater switch.

When not in use, put the switch in the neutral position. The indicator will turn off.

### ■ Operation condition

The seat heaters can be used when the power switch is in ON.



### WARNING

#### ■ To prevent causes of overheating and minor burn injuries

Observe the following precautions when using a seat heater:

- Do not cover the seat with a blanket or cushion when using the seat heater.
- Do not use seat heater more than necessary.

## Operating the seat heaters and ventilators

Turns the seat heaters and ventilators on/off

The level indicators A come on during operation.

Each time the switch is pressed, the operation condition changes as follows.

Hi (3 segments lit) → Mid (2 segments lit) → Lo (1 segment lit) → Off

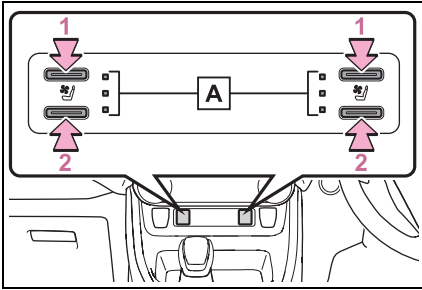

**1** Turns the seat heater on

The level indicators **A** come on yellow during operation.

**2** Turns the seat ventilator on

The level indicators **A** come on green during operation.

#### ■ Operation condition

The power switch is in ON.

#### ■ Air conditioning system-linked control mode

When a seat ventilator is set to Hi, the fan speed of the seat ventilator may increase according to the fan speed of the air conditioning system.



#### WARNING

##### ■ To prevent causes of overheating and minor burn injuries

Observe the following precautions when using a seat heater:

- Do not cover the seat with a blanket or cushion when using the seat heater.
- Do not use seat heater more than necessary.

## Interior lights list

### Location of the interior lights

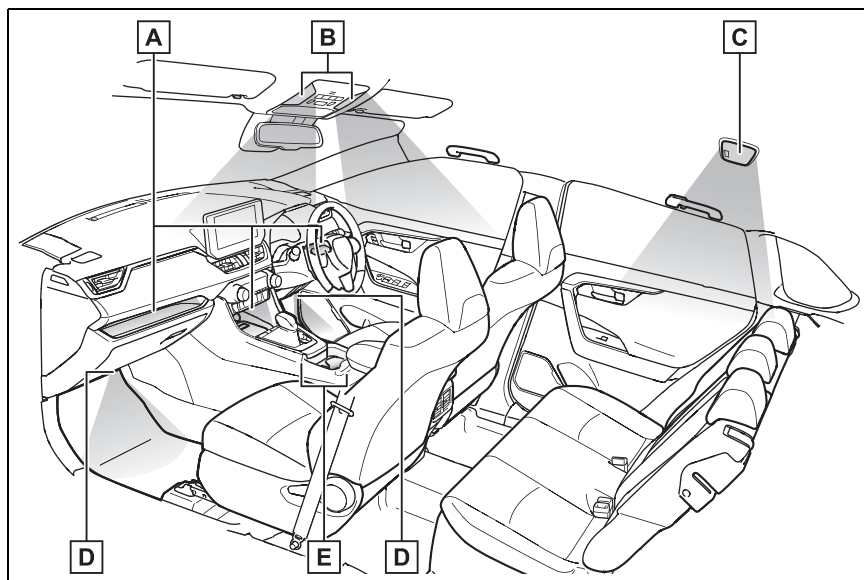

- A** Open tray lights (if equipped)\*
- B** Front interior lights/personal lights (→P.307)
- C** Rear interior light (→P.307)
- D** Footwell lights (if equipped)\*
- E** Front cup holder lights (if equipped)\*

\*: These lights turn on when a door is unlocked.

When the shift lever is in a position other than P, the brightness of these lights will reduce intensity.

#### ■ Illuminated entry system

The lights automatically turn on/off according to the power switch mode, the presence of the electronic key, whether the doors are locked/unlocked, and whether the doors are opened/closed.

#### ■ To prevent the 12-volt battery from being discharged

If the interior lights remain on when the

power switch is turned to OFF, the lights will go off automatically after 20 minutes.

#### ■ The interior lights may turn on automatically when

If any of the SRS airbags deploy (inflate) or in the event of a strong rear impact, the interior lights will turn on automatically.

The interior lights will turn off automati-

cally after approximately 20 minutes.

The interior lights can be turned off manually. However, in order to help prevent further collisions, it is recommended that they be left on until safety can be ensured.

(The interior lights may not turn on automatically depending on the force of the impact and conditions of the collision.)

### ■ Customization

Setting (e.g. the time elapsed before the lights turn off) can be changed. (Customizable features: →P.440)



### NOTICE

#### ■ To prevent 12-volt battery discharge

Do not leave the lights on longer than necessary when the hybrid system is off.

## Operating the interior lights

### ■ Front interior lights

Turns the lights on/off

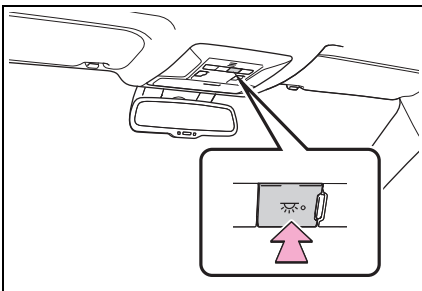

Turns the switch to the door position (door linked)

When a door is opened while the door position is on, the lights turn on.

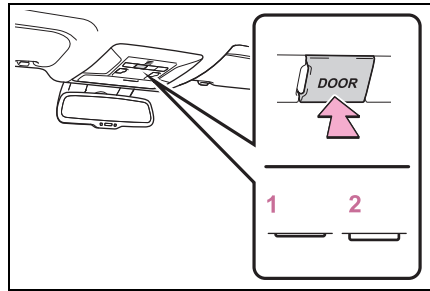

1 Turns the door position on

2 Turns the lights off

### ■ Rear interior light

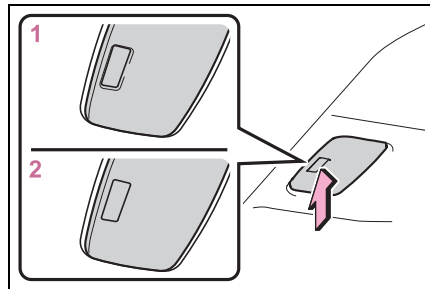

1 Turns the light on

2 Turns the door-linked function on (door position)

The light turns on/off according to the opening/closing of the doors.

## Operating the personal lights

Turns the lights on/off

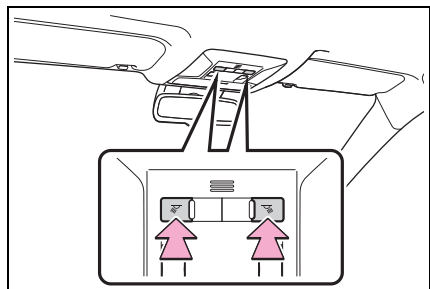

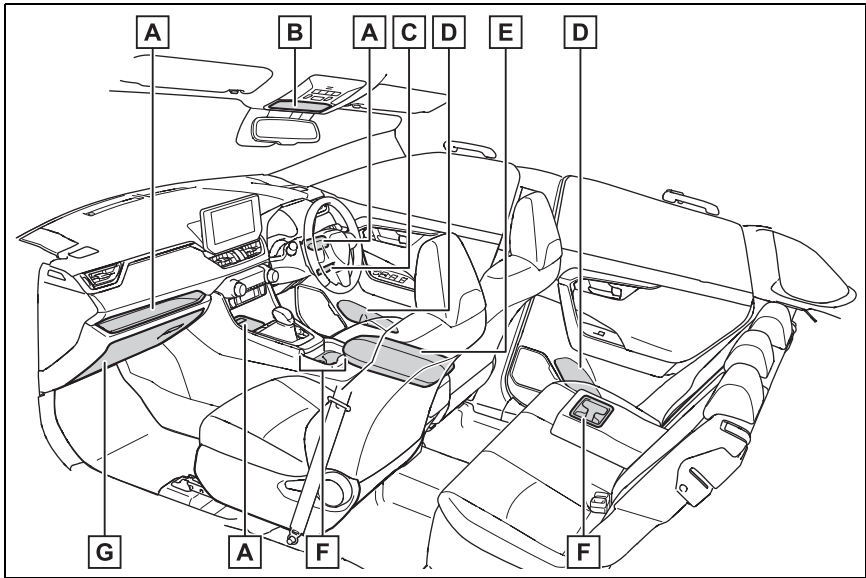
**List of storage features****Location of the storage features**

- A** Open tray (→P.311)
- B** Auxiliary box (→P.310)
- C** Card holder (→P.311)
- D** Bottle holders (→P.310)
- E** Console box (→P.309)
- F** Cup holders (→P.309)
- G** Glove box (→P.309)

### **! WARNING**

#### **■ Items that should not be left in the vehicle**

Do not leave glasses, lighters or spray cans in the storage spaces, as this may cause the following when cabin temperature becomes high:

- Glasses may be deformed by heat or cracked if they come into contact with other stored items.
- Lighters or spray cans may explode. If they come into contact with other stored items, the lighter may catch fire or the spray can may release gas, causing a fire hazard.

### **Glove box**

Pull up the lever to open the glove box.

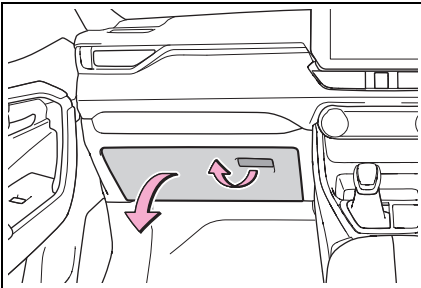

### **! WARNING**

#### **■ Caution while driving**

Keep the glove box closed. In the event of sudden braking or sudden swerving, an accident may occur due to an occupant being struck by the open glove box or the items stored inside.

### **Console box**

Lift the lid while pushing the button to release the lock.

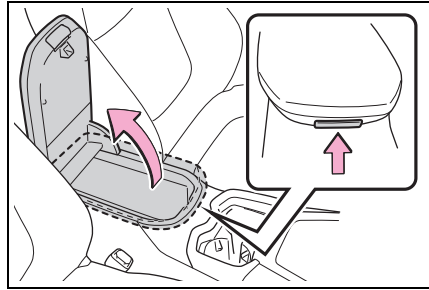

#### **■ Console box tray (if equipped)**

The tray can be removed and stored in the bottom of the console box.

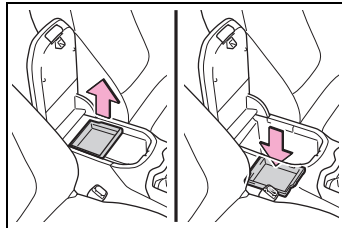

### **! WARNING**

#### **■ Caution while driving**

Keep the console box closed. Injuries may result in the event of an accident or sudden braking.

### **Cup holders**

#### ► Front

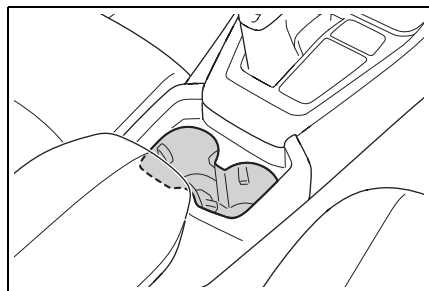

#### ► Rear

Pull the armrest down

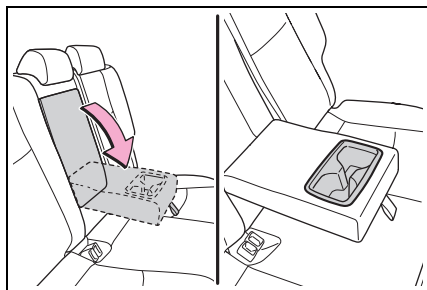

**⚠ WARNING**

**■ Items unsuitable for the cup holders**

Do not place anything other than cups or beverage cans in the cup holders. Inappropriate items must not be stored in the cup holders even if the lid is closed.

Other items may be thrown out of the holders in the event of an accident or sudden braking and cause injury. If possible, cover hot drinks to prevent burns.

**Bottle holders**

► Front

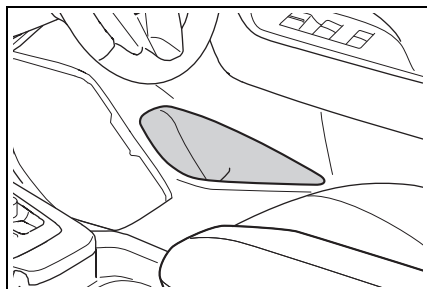

► Rear

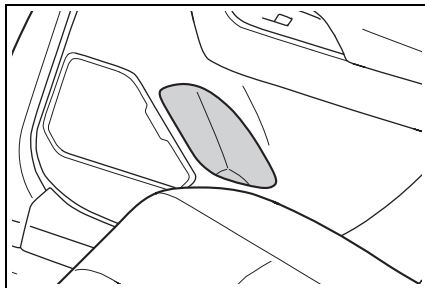

■ **Bottle holders**

- When storing a bottle, close the cap.
- The bottle may not be stored depending on its size or shape.

**⚠ WARNING**

**■ Items unsuitable for the bottle holders**

Do not place anything other than a bottle in the bottle holders. Other items may be thrown out of the holders in the event of an accident or sudden braking and cause injury.

**⚠ NOTICE**

**■ Items that should be not stowed in the bottle holders**

Do not place open bottles or glass and paper cups containing liquid in the bottle holders. The contents may spill and glasses may break.

**Auxiliary box**

Push the lid.



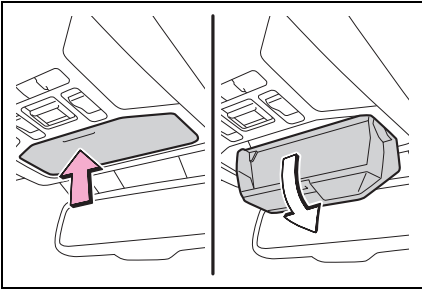

**⚠ WARNING**

**■ Caution while driving**

Do not leave the auxiliary box open while driving.

Injuries may result in the event of an accident or sudden braking.

**■ Items unsuitable for storing**

Do not store items heavier than 200 g (0.44 lb.).

Doing so may cause the auxiliary box to open and the items inside may fall out, resulting in an accident.

**Card holder**

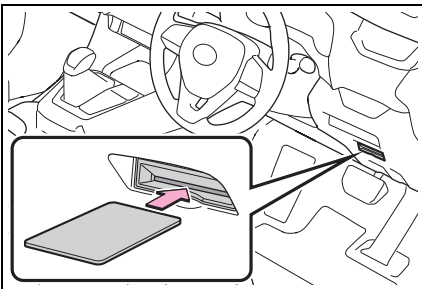

**Open tray**

► Driver's side

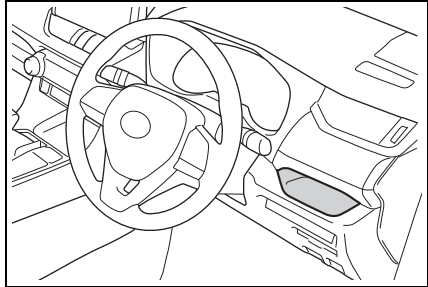

► Front passenger's side

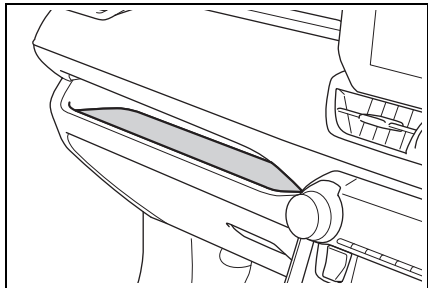

► Front of console

Vehicles with wireless charger:

→P.319

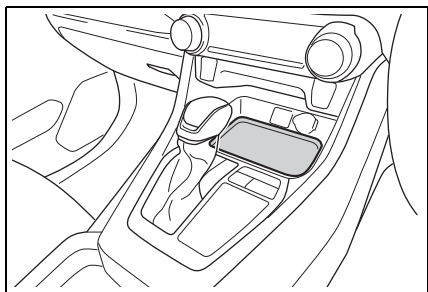

**WARNING**

■ **Items unsuitable for the open tray**

Observe the following precautions when putting items in the open tray. Failure to do so may cause items to be thrown out of the tray in the event of sudden braking or steering. In these cases, the items may interfere with pedal operation or cause driver distraction, resulting in an accident.

- Do not store items in the tray that can easily shift or roll out.
- Do not stack items in the tray higher than the tray's edge.
- Do not put items in the tray that may protrude over the tray's edge.

## Luggage compartment features

### Cargo hooks

Raise the hook to use.

The cargo hooks are provided for securing loose items.

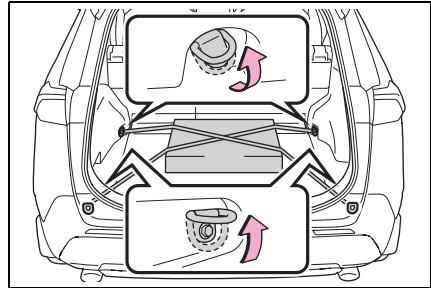
**WARNING**

■ **When cargo hooks are not in use**

To avoid injury, always return the hooks to their stowed positions when not in use.

### Deck board

- **Flipping the deck board upside down (except for vehicles with full-size spare tire)**

The deck board can be flipped upside down (resin side up) depending on the situation.

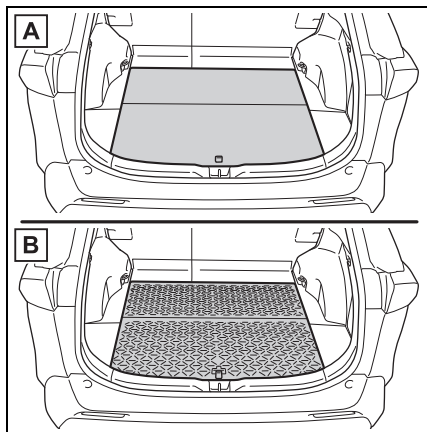

**A** Original position

**B** Underside (resin side)

■ **Changing the deck board positions (except for vehicles with full-size spare tire)**

Height of the deck floor can be changed by setting the deck board under the floor.

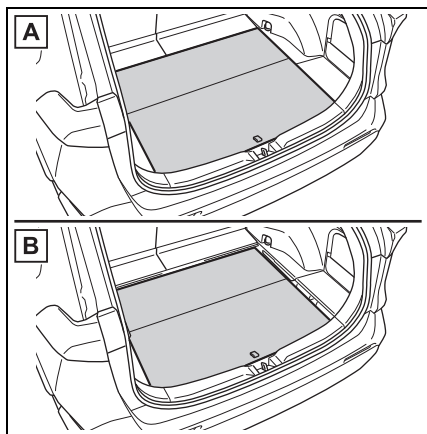

**A** Upper

**B** Lower

- 1 Pull up the tab to raise the deck board and move it toward you to remove.

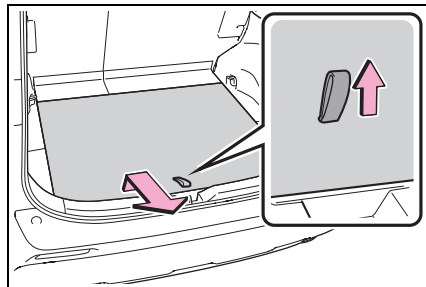

- 2 Place the deck board through the groove and move forward.

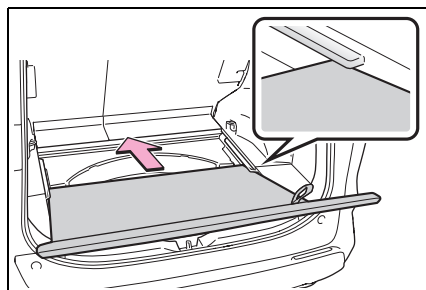

■ **Setting the deck board upright (except for vehicles with full-size spare tire)**

When taking out the tools, the deck board can be set upright.

When the back surface (resin surface) of the deck board is facing up, flip it back to the original position.

- 1 Pull up the tab to raise the deck board and fold it forward.

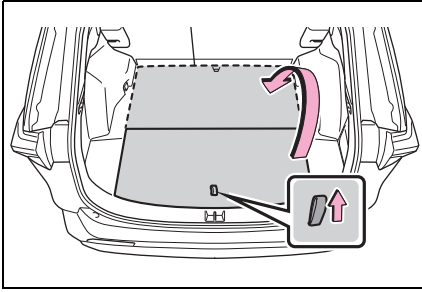

- 2 Place the edge into the groove (A), and with the deck board in a standing state, put the edge into the holes (B).

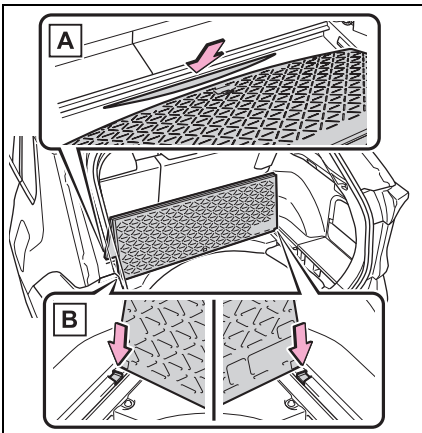

**⚠ WARNING**

**■ When operating the deck board**

Do not place anything on the deck board when operating the board. Otherwise, your fingers may be caught or an accident may result causing injuries.

**■ Caution while driving**

Keep the deck board closed.

In the event of sudden braking, an accident may occur due to an occupant being struck by the deck board or the items stored under the deck board.

**Side auxiliary box**

► Type A

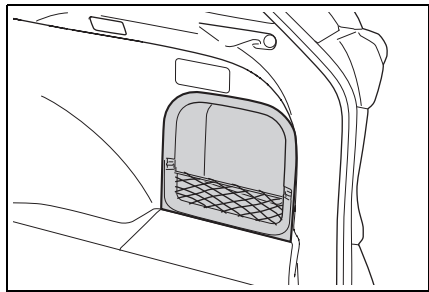

► Type B

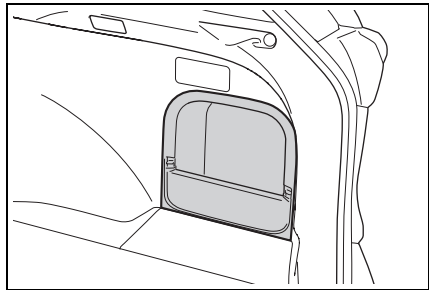

**■ Removing the partition plate**

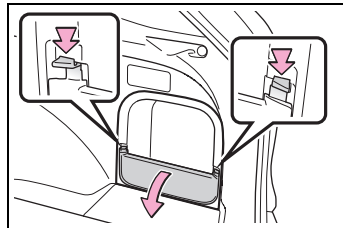

Disengage the claws

## Luggage cover (if equipped)

### ■ Installing the luggage cover

- 1 Compress the both ends of the luggage cover and insert into the recess to install.

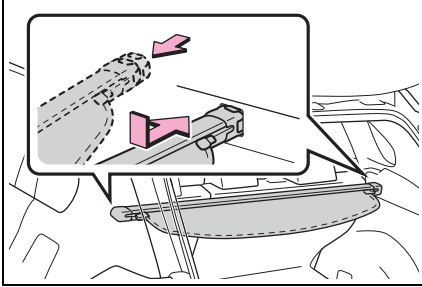

- 2 Pull out the luggage cover and hook it onto the anchors.

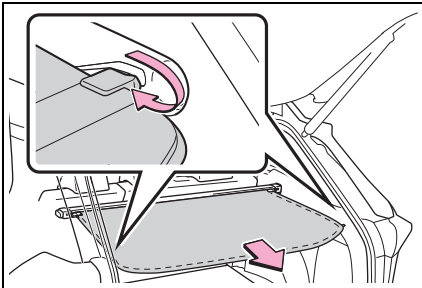

### ■ Removing the luggage cover

- 1 Release the cover from the left and right anchors and allow it to retract.

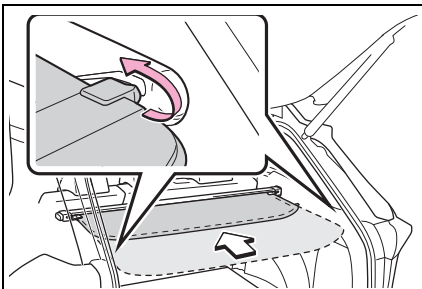

- 2 Compress the end of the luggage cover and lift the luggage cover up.

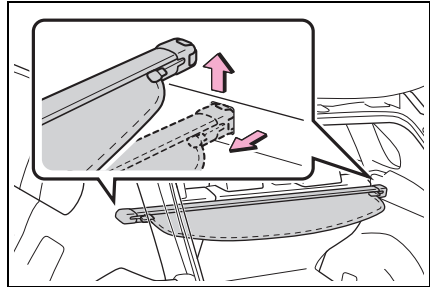

### ■ Stowing the luggage cover (except for vehicles with full-size spare tire)

- 1 Open the rear deck board and remove the side deck covers.

When the back surface (resin surface) of the deck board is facing up, remove the deck board.

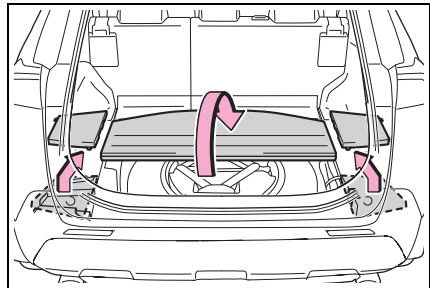

- 2 Place the both ends of the luggage cover into the holder.

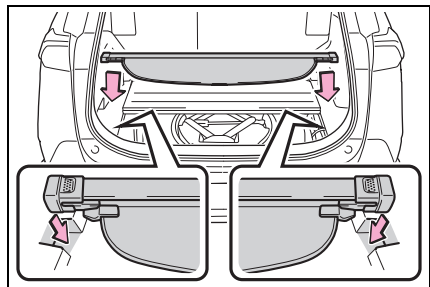

**WARNING****■ Luggage cover**

- When installing/stowing the luggage cover, make sure that the luggage cover is securely installed/stowed. Failure to do so may result in serious injury in the event of sudden braking or a collision.
- Do not place anything on the luggage cover. In the event of sudden braking or turning, the item may go flying and strike an occupant. This could lead to an unexpected accident, resulting in death or serious injury.
- Do not allow children to climb on the luggage cover. Climbing on the luggage cover could result in damage to the luggage cover, possibly causing death or serious injury to the child.

**NOTICE****■ To prevent damage to the luggage cover**

Do not place anything on top of the luggage cover. When rolling up the luggage cover, objects may be caught in the cover, damaging the cover and generating noise.

## Other interior features

### Sun visors

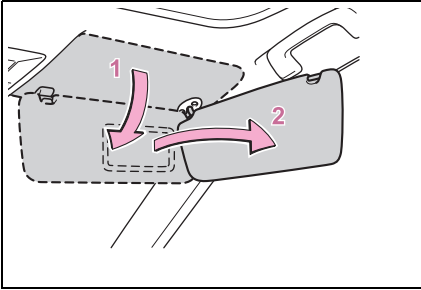

- 1** To set the visor in the forward position, flip it down.
- 2** To set the visor in the side position, flip down, unhook, and swing it to the side.

### Vanity mirrors

Slide the cover to open.

The light turns on when the cover is opened.

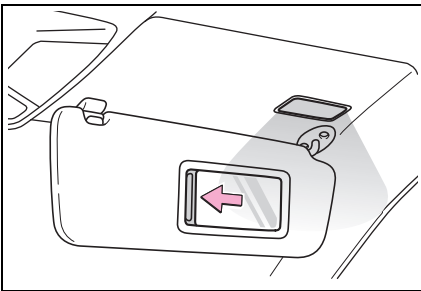

#### ■ Automatic light off to prevent 12-volt battery discharge

If the vanity lights remain on when the power switch is turned to OFF, the lights will go off automatically after 20 minutes.

#### ⚠ NOTICE

#### ■ To prevent 12-volt battery discharge

Do not leave the vanity lights on for extended periods while the hybrid system is off.

### Power outlet

Please use a power supply for electronic goods that use less than 12 VDC /10 A (power consumption of 120 W).

When using electronic goods, make sure that the power consumption of all the connected power outlets is less than 120 W.

#### ■ Front

Open the lid.

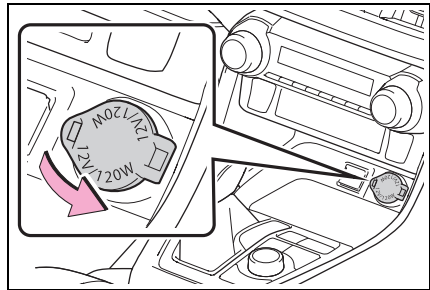

#### ■ Luggage compartment

Open the lid.

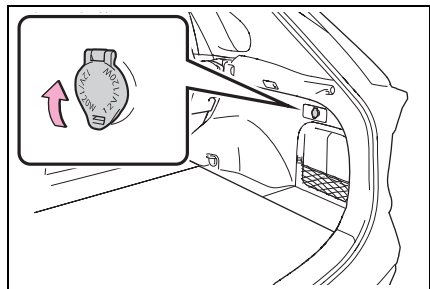

### ■ The power outlet can be used when

The power switch is in ACC or ON.

### ■ When stopping the hybrid system

Disconnect electrical devices with charging functions, such as mobile battery packs.

If such devices are left connected, the hybrid system may not stop normally.



### NOTICE

#### ■ When power outlet is not in use

To avoid damaging the power outlet, close the power outlet lid when the power outlet is not in use.

Foreign objects or liquids that enter the power outlet may cause a short circuit.

#### ■ To prevent blown fuse

Do not use an accessory that uses more than 12 V 10 A.

#### ■ To prevent 12-volt battery discharge

Do not use the power outlet longer than necessary when the hybrid system is off.

## USB Type-C charging ports

The USB Type-C charging ports are used to supply 3 A of electricity at 5 V to external devices.

The USB Type-C charging ports are for charging only. They are not designed for data transfer or other purposes.

Depending on the external device, it may not charge properly. Refer to the manual included with the device before using a USB charging port.

## ■ Using the USB Type-C charging ports

### ▶ Console box

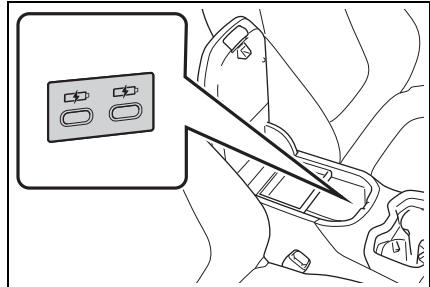

### ▶ Rear

Open the lid.

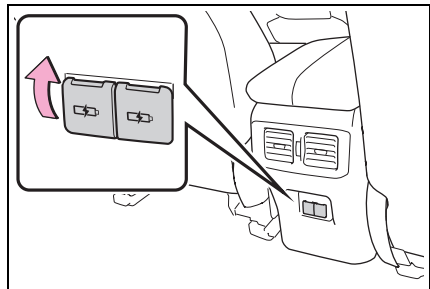

## ■ The USB Type-C charging ports can be used when

The power switch is in ACC or ON.

## ■ Situations in which the USB Type-C charging ports may not operate correctly

- If a device which consumes more than 3 A at 5 V is connected
- If a device designed to communicate with a personal computer, such as a USB memory device, is connected
- If the connected external device is turned off (depending on device)
- If the temperature inside the vehicle is high, such as after the vehicle has been parked in the sun



### ■ About connected external devices

Depending on the connected external device, charging may occasionally be suspended and then start again. This is not a malfunction.



#### NOTICE

#### ■ To prevent damage to the USB Type-C charging ports

- Do not insert foreign objects into the ports.
- Do not spill water or other liquids into the ports.
- When the USB Type-C charging ports are not in use, close the lids. If a foreign object or liquid enters a port may cause a short circuit.
- Do not apply excessive force to or impact the USB Type-C charging ports.
- Do not disassemble or modify the USB Type-C charging ports.

#### ■ To prevent damage to external devices

- Do not leave external devices in the vehicle. The temperature inside the vehicle may become high, resulting in damage to an external device.
- Do not push down on or apply unnecessary force to an external device or the cable of an external device while it is connected.

#### ■ To prevent 12-volt battery discharge

Do not use the USB Type-C charging ports for a long period of time when the hybrid system is off.

### Wireless charger (if equipped)

A portable device can be charged by just placing Qi standard wireless

charge compatible portable devices according to the Wireless Power Consortium, such as smartphones and mobile batteries, etc., on the charge area.

This function cannot be used with portable devices that are larger than the charging tray. Also, depending on the portable device, it may not operate as normal. Please read the operation manual for portable devices to be used.

### ■ The “Qi” logo

The “Qi” logo is a trademark of the Wireless Power Consortium.



### ■ Name for all parts

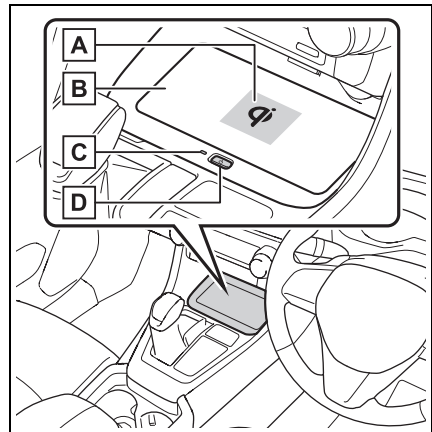

- A** Charge area\*
- B** Charging tray
- C** Operation indicator light
- D** Power supply switch

\*: Portable devices and wireless chargers contain charging coils. The charging coil in the wireless charger can be moved within the charge area near the center of the charging tray. If the charging coil inside a portable device is detected in the charge area, the charging coil inside the wireless charger will move toward it and start charging. If the charging coil inside a portable device moves outside of the charge area, charging will automatically stop.

If 2 or more portable devices are placed on the charging tray, their charging coils may not be properly detected and they may not be charged.

### ■ Using the wireless charger

- 1 Press the power supply switch of the wireless charger.

Switches on and off with each press of the power supply switch.

When turned on, the operation indicator light (green) comes on.

Even with the hybrid system off, the on/off state of the power supply switch is memorized.

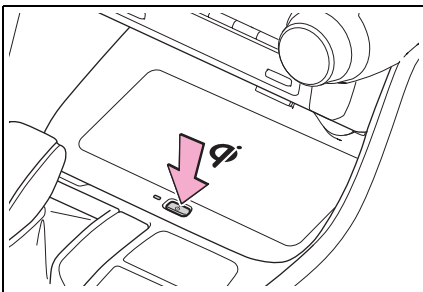

- 2 Place the portable device on the charging tray

Place the charging side of the portable device down with the center of the device in the center of the charge area. Depending on the portable device, its

charging coil may not be in the center of the device. In this case, place the portable device so that its charging coil is centered in the charging area.

When charging, the operation indicator light (orange) comes on.

If charging is not occurring, try placing the portable device as close to the center of the charging area as possible. If charging is not performed, the operation indicator light will slowly illuminate in green and orange alternatively and a sound of charging coil operation may be heard repeatedly.

When charging is complete, the operation indicator light (green) comes on.

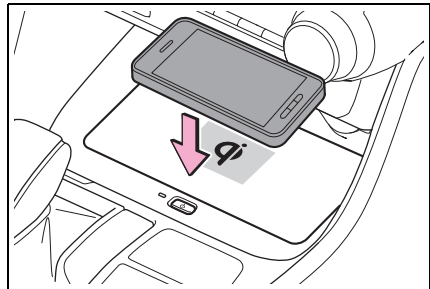

### ■ Recharging function

- When charging is complete and after a fixed time in the charge suspension state, charging restarts.
- If a portable device is moved significantly within the charging area, the charging coil may disconnect and charging may temporarily be stopped. However, if a charging coil is detected within the charging area, the charging coil inside the wireless charger will move near the other coil and charging will resume.

### ■ Rapid charging function

- The following portable devices

support rapid charging.

- Portable devices compliant with WPC Ver1.2.4 and compatible with rapid charging
- iPhone's with an iOS version that supports 7.5 W charging (iPhone 8 and later models)
- To switch to the rapid charging function, press the power supply switch 3 times while charging. When rapid charging is possible, the operation indicator light will switch from orange to flashing between green and orange.
- When charging is complete, the rapid charging function will stop. Switch again to the rapid charging function to use rapid charging again.

#### ■ Lighting conditions of operation indicator light

Operation indicator light	Conditions
Turning off	When the Wireless charger power supply is off
Green (comes on)	On Standby (charging possible state) <sup>*1</sup>
	When charging is complete <sup>*2</sup>

Operation indicator light	Conditions
Orange (comes on)	When placing the portable device on the charging area (detecting the portable device)
	Charging
Flashing between green and orange	When any of the following portable devices is using rapid charging <ul style="list-style-type: none"> <li>• Portable devices compliant with WPC Ver1.2.4 and compatible with rapid charging</li> <li>• iPhone's with an iOS version that supports 7.5 W charging (iPhone 8 and later models)</li> </ul>

<sup>\*1</sup>: Charging power will not be output during standby. A metallic object will not be heated, if it is placed on the charging tray in this state.

<sup>\*2</sup>: Depending on the portable device, there are cases where the operation indicator light will continue being lit up orange even after the charging is complete.

#### ■ When the operation indicator light flashes

When an error occurs, the operation indicator light flashes an orange color.

Handle the error based on the following tables.

- Flashing repeatedly once every second (Orange)

Suspected causes	Handling method
Vehicle to charger communication failure.	If the hybrid system is running, stop and then restart the hybrid system. If the power switch is in ACC, start the hybrid system. (→P.177)

- Repeatedly flashes 3 times continuously (Orange)

Suspected causes	Handling method
Foreign substance detection: A metallic foreign substance is in the charge area, and so the abnormal heating prevention function operated	Remove the foreign substance from the charge area.
Portable device misaligned: The charging coil in the portable device moved outside of the charge area, and so the abnormal heating prevention function operated	Remove the portable device from the charging tray, check that the operation indicator light switches back to green, and then once again place the device near the center of the charging tray. If there is a case or cover attached to the portable device, remove it.

- Repeatedly flashes 4 times continuously (Orange)

Suspected causes	Handling method
Safety shutdown resulting when the temperature within the wireless charger exceeded the set value	Stop charging, remove the portable device from the charging tray, wait for the temperature to drop, and then start charging again.

■ **The wireless charger can be operated when**

The power switch is in ACC or ON.

■ **Usable portable devices**

- Qi standard wireless charge standard can be used on compatible devices. However, not all Qi standard devices and compatibility are guaranteed.
- Starting with mobile phones and smartphones, it is aimed for low power electrically supplied portable devices of no more than 5W.
- However, charging exceeding 5 W is supported by the following portable devices.
  - Charging at 7.5 W or less is supported by iPhone's that support 7.5 W charging.
  - Charging at 10 W or less is supported by portable devices compliant with EPP output as defined by WPC standard Ver1.2.4.

■ **Using the smart entry & start system**

If the smart entry & start system detects the key while a device is being charged, charging will be temporarily stopped.

■ **When covers and accessories are attached to portable devices**

Do not charge in situations where cover and accessories not able to handle Qi are attached to the portable device. Depending on the type of cover (includ-

ing the certain genuine manufacture parts) and accessory, it may not be possible to charge. When charging is not performed even with the portable device placed on the charge area, remove the cover and accessories.

#### ■ While charging, noise enters the AM radio

- Turn off the wireless charger and confirm that the noise has decreased. If the noise decreases, continuously pushing the power supply switch of the wireless charger for 2 seconds, the frequency of the charger can be changed and the noise can be reduced. Also, on that occasion, the operation indicator light will flash orange 2 times.
- iPhone's use a particular frequency for rapid charging. Depending on the iOS version, rapid charging may not be performed while switching frequencies.

#### ■ Important points of the wireless charger

- If the electronic key cannot be detected within the vehicle interior, charging cannot be done. When the door is opened and closed, charging may be temporarily suspended.
- When charging, the wireless charging device and portable device will get warmer, however this is not a malfunction. When a portable device gets warm while charging, charging may stop due to the protection function on the portable device side. In this case, when the temperature of the portable device drops significantly, charge again.

The fan may start operating to lower the temperature inside the wireless charger, however this is not a malfunction.

#### ■ Operation sounds

A buzzing noise may be heard when pressing the power supply switch to turn the power supply on, when turning the

power switch to ACC or ON while the wireless charger power supply is on, or when detecting a portable device. However, this is not a malfunction.

#### ■ If the smartphone OS has been updated

If the smartphone OS has been updated to a newer version, its charging specifications may have changed significantly. For details, check the information on the manufacturer's website.

#### ■ Trademark information

iPhone is a trademark of Apple Inc., registered in the U.S. and other countries.



#### WARNING

##### ■ Caution while driving

When charging a portable device, for safety reasons, the driver should not operate the main part of the portable device while driving.

##### ■ Caution while in motion

Do not charge lightweight devices such as wireless headphones while in motion. These devices are very light and may be ejected from the charging tray, which may lead to unforeseen accidents.

##### ■ Caution regarding interference with electronic devices

People with implantable cardiac pacemakers, cardiac resynchronization therapy-pacemakers or implantable cardioverters, as well as any other electrical medical device, should consult their physician about the usage of the wireless charger.

**WARNING****■ To prevent malfunctions or burns**

Observe the following precautions. Failure to do so may result in a equipment failure and damage, catch fire, burns due to overheat or electric shock.

- Do not insert any metallic objects between the charge area and the portable device while charging
- Do not attach an aluminum sticker or other metallic object to the charge area
- Do not attach an aluminum sticker or other metallic object to the side of the portable device (or to its case or cover) that touches the charge area
- Do not use the charging tray as a small storage space
- Do not subject to a strong force or impact
- Do not disassemble, modify or remove
- Do not charge devices other than specified portable devices
- Keep away from magnetic items
- Do not charge devices if the charge area is covered in dust
- Do not cover with a cloth or similar material

**NOTICE****■ Situations in which the function may not operate normally**

Devices may not be charged normally in the following situations.

- The portable device is fully charged
- The portable device is being charged with a cable connected

- There is foreign matter between the charge area and portable device
- Charging has caused the portable device to heat up
- The temperature around the charging tray is 35°C (95°F) or higher, such as in extreme heat
- The portable device is placed with its charging side facing up
- When the charging coil for the portable device is misaligned from the charge area (In particular, small portable devices such as foldable devices may be misaligned from the charging area while driving)
- The portable device is larger than the charging tray
- The camera lens protrudes 3 mm (0.12 in) or more from the surface of the portable device
- The vehicle is in an area where strong electrical waves or noise are emitted, such as near a television tower, power plant, gasoline station, broadcasting station, large display, airport, etc.
- Any of the following objects that is 2 mm (0.08 in) or thicker is between the charging side of the portable device and the charge area
  - Thick cases or covers
  - Thick decorations
  - Accessories, such as finger rings, straps, etc.
- When the portable device is in contact with, or is covered by any of the following metallic objects:
  - A card that has metal on it, such as aluminum foil, etc.
  - A pack of cigarettes that includes aluminum foil

**NOTICE**

- A wallet or bag that is made of metal
- Coins
- A heating pad
- CDs, DVDs or other media
- A metal accessory
- A case or cover made of metal
- Casing which has magnet in it on the charging side of the portable device
- Electric wave type wireless remote controls are being used nearby
- The electronic key is not inside the vehicle
- 2 or more portable devices are placed on the charging tray at the same time

If charging is abnormal or the operation indicator light continues to flash for any other reason, the wireless charger may be malfunctioning. Contact your Toyota dealer.

■ **To prevent malfunctions and data corruptions**

- When charging, bringing a credit, or other magnetic card, or magnetic storage media close to the charge area may clear any stored data due to magnetic influence. Also, do not bring a wristwatch or other precision instrument close to the charge area since doing so may cause it to malfunction.

- Do not charge with a non-contact IC card such as a transportation system IC card inserted between the charging side of a portable device and the charge area. The IC chip may become extremely hot and damage the portable device or IC card. Be especially careful not to charge a portable device inside a case or cover with a non-contact IC card attached.

- Do not leave portable devices inside the vehicle. The inside of the vehicle can become hot in extreme heat, which could cause a malfunction.

■ **To prevent 12-volt battery discharge**

Do not use the wireless charger for a long period of time when the hybrid system is stopped.

## Armrest

Fold down the armrest for use.

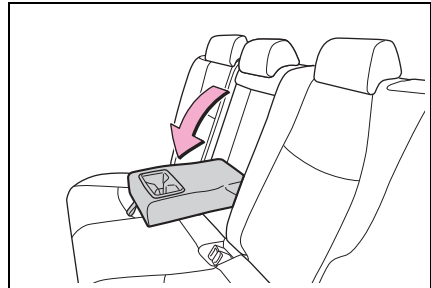
**NOTICE**

■ **To prevent damage to the armrest**

Do not apply too much load on the armrest.

## Assist grips

An assist grip installed on the ceil-

ing can be used to support your body while sitting on the seat.

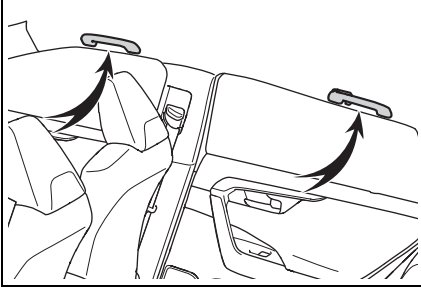

#### WARNING

##### ■ Assist grips

Do not use the assist grip when getting in or out of the vehicle or rising from your seat.



#### NOTICE

##### ■ To prevent damage to the assist grip

Do not hang any heavy object or put a heavy load on the assist grip.

### Coat hooks

The coat hooks are provided with the rear assist grips.

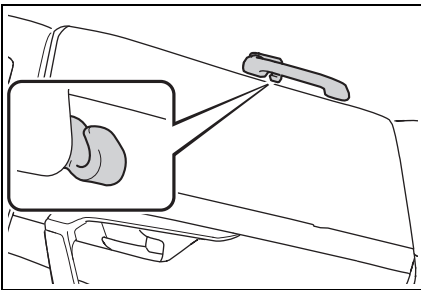

#### WARNING

##### ■ Items that must not be hanged on the hook

Do not hang coat hangers or other hard or sharp objects on the hook. If the SRS curtain shield airbags deploy, these items may become projectiles, causing death or serious injury.



**6-1. Maintenance and care**

Cleaning and protecting the  
vehicle exterior ..... **328**

Cleaning and protecting the  
vehicle interior ..... **332**

**6-2. Maintenance**

Maintenance requirements  
..... **335**

**6-3. Do-it-yourself maintenance**

Do-it-yourself service precau-  
tions ..... **337**

Hood ..... **339**

Positioning a floor jack..... **340**

Engine compartment ..... **342**

12-volt battery ..... **347**

Tires..... **349**

Tire inflation pressure ..... **351**

Wheels..... **352**

Air conditioning filter ..... **353**

Cleaning the hybrid battery  
(traction battery) air intake  
vent..... **355**

Wiper insert replacement.. **359**

Electronic key battery ..... **363**

Checking and replacing fuses  
..... **365**

Light bulbs ..... **367**

## Cleaning and protecting the vehicle exterior

Perform the following to protect the vehicle and maintain it in prime condition:

### Cleaning instructions

- Working from top to bottom, liberally apply water to the vehicle body, wheel wells and underside of the vehicle to remove any dirt and dust.
- Wash the vehicle body using a sponge or soft cloth, such as a chamois.
- For hard-to-remove marks, use car wash soap and rinse thoroughly with water.
- Wipe away any water.
- Wax the vehicle when the waterproof coating deteriorates.

If water does not bead on a clean surface, apply wax when the vehicle body is cool.

### Automatic car washes

- Before washing the vehicle:
  - Fold the mirrors
  - Turn off the power back door (if equipped)

Start washing from the front of the vehicle. Make sure to extend the mirrors before driving.

- Brushes used in automatic car washes may scratch the vehicle surface, parts (wheel, etc.) and harm your vehicle's paint.

- Rear spoiler may not be washable in some automatic car washes. There may also be an increased risk of damage to vehicle.

### High pressure car washes

As water may enter the cabin, do not bring the nozzle tip near the gaps around the doors or perimeter of the windows, or spray these areas continuously.

### Note for a smart entry & start system (vehicles with entry function)

If the door handle becomes wet while the electronic key is within the effective range, the door may lock and unlock repeatedly. In that case, follow the following correction procedures to wash the vehicle:

- Place the key in a position 2 m (6 ft.) or more separate from the vehicle while the vehicle is being washed. (Take care to ensure that the key is not stolen.)
- Set the electronic key to battery-saving mode to disable the smart entry & start system. (→P.130)

### Wheels and wheel ornaments (vehicles without matte painted wheels)

- Remove any dirt immediately by using a neutral detergent.
- Wash detergent off with water immediately after use.
- To protect the paint from damage, make sure to observe the following precautions.
  - Do not use acidic, alkaline or abrasive detergent.
  - Do not use hard brushes.
  - Do not use detergent on the wheels when they are hot, such as after driving or parking in hot weather.

### Wheels and wheel ornaments (vehicles with matte painted wheels)

A different set of care is necessary for matte painted wheels and wheel ornaments.

Contact your Toyota dealer for details.

- Remove dirt using water as early as possible.  
If the wheels are excessively dirty, use diluted neutral detergent.
- When using detergent, make sure to rinse it off with water immediately.  
Then use a soft cloth to wipe off the water.
- Use a sponge or soft cloth to remove the dirt by hand.
- To prevent the matte paint from being damaged or glossy, make sure to observe the following precautions:
  - Do not apply any coatings or wax.
  - Do not use acidic, alkaline or abrasive detergents.
  - When using tire cleaners or tire wax, do not allow them to be applied to the wheels.
  - Do not scrub or polish the wheels using a brush or dry cloth, etc.
  - When using an automatic car wash, do not select the wheel brush function.
  - Do not use a high pressure washer or steam cleaner.
  - Do not use detergent on the wheels when they are hot, such as after driving or parking in hot weather.

#### ■ Brake pads and calipers

Rust may form if the vehicle is parked with wet brake pads or disc rotors, causing them to stick. Before parking the vehicle after it is washed, drive slowly and apply the brakes several times to dry the parts.

#### ■ Bumpers

Do not scrub with abrasive cleaners.

#### ■ Plated portions

If dirt cannot be removed, clean the parts as follows:

- Use a soft cloth dampened with an approximately 5% solution of neutral detergent and water to clean the dirt off.
- Wipe the surface with a dry, soft cloth to remove any remaining moisture.
- To remove oily deposits, use alcohol

wet wipes or a similar product.

### ⚠ WARNING

#### ■ When washing the vehicle

Do not apply water to the inside of the engine compartment. Doing so may cause the electrical components, etc. to catch fire.

#### ■ When cleaning the windshield

Set the wiper switch to off.

If the wiper switch is in "AUTO", the wipers may operate unexpectedly in the following situations, and may result in hands being caught or other serious injuries and cause damage to the wiper blades.

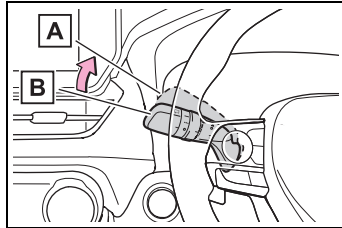

A Off

B "AUTO"

- When the upper part of the windshield where the raindrop sensor is located is touched by hand
- When a wet rag or similar is held close to the raindrop sensor
- If something bumps against the windshield
- If you directly touch the raindrop sensor body or if something bumps into the raindrop sensor

**WARNING****■ Precautions regarding the exhaust pipes**

Exhaust gasses cause the exhaust pipes to become quite hot.

When washing the vehicle, be careful not to touch the pipes until they have cooled sufficiently, as touching hot exhaust pipes can cause burns.

**■ Precaution regarding the rear bumper**

If the paint of the rear bumper is chipped or scratched, the following systems may not function correctly. If this occurs, consult your Toyota dealer.

- BSM (if equipped)
- RCTA (if equipped)
- PKSB (if equipped)
- Toyota parking assist-sensor

**NOTICE****■ To prevent paint deterioration and corrosion on the body and components (aluminum wheels, etc.)**

- Wash the vehicle immediately in the following cases:
  - After driving near the sea coast
  - After driving on salted roads
  - If coal tar or tree sap is present on the paint surface
  - If dead insects, insect droppings or bird droppings are present on the paint surface
  - After driving in an area contaminated with soot, oily smoke, mine dust, iron powder or chemical substances
  - If the vehicle becomes heavily soiled with dust or mud
  - If liquids such as benzene and gasoline are spilled on the paint surface
- If the paint is chipped or scratched, have it repaired immediately.
- To prevent the wheels from corroding, remove any dirt and store in a place with low humidity when storing the wheels.

**■ Cleaning the exterior lights**

- Wash carefully. Do not use organic substances or scrub with a hard brush.  
This may damage the surfaces of the lights.
- Do not apply wax to the surfaces of the lights.  
Wax may cause damage to the lenses.



## NOTICE

**■ When using an automatic car wash**

Set the wiper switch to off position. If the wiper switch is in "AUTO", the wipers may operate and the wiper blades may be damaged.

**■ When using a high pressure car wash**

- When washing the vehicle, do not let water from the high-pressure washer directly hit the camera (if equipped) or the area around the camera. Due to the shock from the high pressure water, it is possible that the device may not operate normally.
- Do not spray water directly on the radar which is equipped behind the radar sensor cover. Otherwise it may cause the device to be damaged.
- Do not bring the nozzle tip close to boots (rubber or resin manufactured cover), or connectors or the following parts.  
The parts may be damaged if they come into contact with high-pressure water.
  - Traction related parts
  - Steering parts
  - Suspension parts
  - Brake parts
- Keep the cleaning nozzle at least 30 cm (11.9 in.) away from the vehicle body. Otherwise resin section, such as moldings and bumpers, may be deformed and damaged. Also, do not continuously hold the nozzle in the same place.
- Do not spray the lower part of the windshield continuously. If water enters the air conditioning system intake located near the lower part of the windshield, the air conditioning system may not operate correctly.

- Do not wash the underside of the vehicle using a high pressure car washer.

## Cleaning and protecting the vehicle interior

Perform cleaning in a manner appropriate to each component and its material.

### Protecting the vehicle interior

- Remove dirt and dust using a vacuum cleaner. Wipe dirty surfaces with a cloth dampened with lukewarm water.
- If dirt cannot be removed, wipe it off with a soft cloth dampened with neutral detergent diluted to approximately 1%.  
Wring out any excess water from the cloth and thoroughly wipe off remaining traces of detergent and water.

#### ■ Shampooing the carpets

There are several commercial foaming-type cleaners available. Use a sponge or brush to apply the foam. Rub in overlapping circles. Do not use water. Wipe dirty surfaces and let them dry. Excellent results are obtained by keeping the carpet as dry as possible.

#### ■ Handling the seat belts

Clean with mild soap and lukewarm water using a cloth or sponge. Also check the belts periodically for excessive wear, fraying or cuts.

### WARNING

#### ■ Water in the vehicle

- Do not splash or spill liquid in the vehicle, such as on the floor, on the rear seats, in the hybrid battery (traction battery) air intake vent or in the luggage compartment.  
(→P.66)  
Doing so may cause the hybrid battery, electrical components, etc. to malfunction or catch fire.
- Do not get any of the SRS components or wiring in the vehicle interior wet.  
(→P.32)  
An electrical malfunction may cause the airbags to deploy or not function properly, resulting in death or serious injury.
- Vehicles with wireless charger:  
Do not let the wireless charger (→P.319) get wet. Failure to do so may cause the charger to become hot and cause burns or could cause electric shock resulting in death or serious injury.

#### ■ Cleaning the interior (especially instrument panel)

Do not use a polish wax or polish cleaner. The instrument panel may reflect off the windshield, obstructing the driver's view and leading to an accident, resulting in death or serious injury.

**NOTICE****■ Cleaning detergents**

- Do not use the following types of detergent, as they may discolor the vehicle interior or cause streaks or damage to painted surfaces:
  - Non-seat portions: Organic substances such as benzene or gasoline, alkaline or acidic solutions, dye, and bleach
  - Seats: Alkaline or acidic solutions, such as thinner, benzene, and alcohol
- Do not use a polish wax or polish cleaner. The instrument panel's or other interior part's painted surface may be damaged.

**■ Preventing damage to leather surfaces**

Observe the following precautions to avoid damage to and deterioration of leather surfaces:

- Remove any dust or dirt from leather surfaces immediately.
- Do not expose the vehicle to direct sunlight for extended periods of time. Park the vehicle in the shade, especially during summer.
- Do not place items made of vinyl, plastic, or containing wax on the upholstery, as they may stick to the leather surface if the vehicle interior heats up significantly.

**■ Water on the floor**

Do not wash the vehicle floor with water.

Vehicle systems such as the audio system may be damaged if water comes into contact with electrical components such as the audio system above or under the floor of the vehicle. Water may also cause the body to rust.

**■ When cleaning the inside of the windshield (vehicles with Toyota Safety Sense)**

Do not allow glass cleaner to contact the lens. Also, do not touch the lens. (→P.205)

**■ Cleaning the inside of the rear window**

- Do not use a glass cleaner to clean the rear window, as this may cause damage to the rear window defogger heater wires. Use a cloth dampened with lukewarm water to gently wipe the window clean. Wipe the window in strokes running parallel to the heater wires.
- Be careful not to scratch or damage the heater wires.

**Cleaning the leather areas**

- Remove dirt and dust using a vacuum cleaner.
- Wipe off any excess dirt and dust with a soft cloth dampened with diluted detergent.

Use a diluted water solution of approximately 5% neutral wool detergent.

- Wring out any excess water from the cloth and thoroughly wipe off all remaining traces of detergent.
- Wipe the surface with a dry, soft cloth to remove any remaining moisture. Allow the leather to dry in a shaded and ventilated area.

**■ Caring for leather areas**

Toyota recommends cleaning the interior of the vehicle at least twice a year to maintain the quality of the vehicle's interior.

### **Cleaning the synthetic leather areas**

- Remove dirt and dust using a vacuum cleaner.
- Wipe it off with a soft cloth dampened with neutral detergent diluted to approximately 1%.
- Wring out any excess water from the cloth and thoroughly wipe off remaining traces of detergent and water.



## Maintenance requirements

**To ensure safe and economical driving, day-to-day care and regular maintenance are essential. Toyota recommends the following maintenance:**



### WARNING

#### ■ If your vehicle is not properly maintained

Improper maintenance could result in serious damage to the vehicle and possible death or serious injury.

#### ■ Handling of the 12-volt battery

12-volt battery posts, terminals and related accessories contain lead and lead compounds which are known to cause brain damage. Wash your hands after handling. (→P.347)

## Scheduled maintenance

Scheduled maintenance should be performed at specified intervals according to the maintenance schedule.

For full details of your maintenance schedule, refer to the “Warranty and Service Booklet”.

## Do-it-yourself maintenance

What about do-it-yourself maintenance?

Many of the maintenance items are easy to do yourself if you have a little mechanical ability and a few basic automotive tools.

Note, however, that some maintenance tasks require special tools and skills. These are best performed by qualified technicians. Even if you are an experienced do-it-yourself mechanic, we recommend that repairs and maintenance be conducted by your Toyota dealer who will keep a record of maintenance on your vehicle. This record could be helpful should you ever require Warranty Service.

### ■ Where to go for the maintenance service?

It makes good sense to take your vehicle to your local Toyota dealer for the maintenance service as well as other inspections and repairs.

Toyota technicians are well-trained specialists receiving the latest service information through technical bulletins, service tips and in-dealership training programs. They learn to work on Toyota before they work on your vehicle, rather than while they are working on it. Doesn't that seem like the best way?

Your Toyota dealer has invested a lot of money in special Toyota tools and service equipment. It helps them to do the job better and at less cost.

Your Toyota dealer's service department will perform all of the scheduled maintenance on your vehicle reliably and economically.

### ■ Does your vehicle need repairs?

Be on the alert for changes in performance and sounds, and visual tip-offs that indicate service is needed. Some important clues are:

- Engine missing, stumbling or ping-pong
- Appreciable loss of power
- Strange engine noises
- A fluid leak under the vehicle (However, water dripping from the air conditioning system after use is normal.)
- Change in exhaust sound (This may

indicate a dangerous carbon monoxide leak. Drive with the windows open and have the exhaust system checked immediately.)

- Flat-looking tires, excessive tire squeal when cornering, uneven tire wear
- Vehicle pulls to one side when driven straight on a level road
- Strange noises related to suspension movement
- Loss of brake effectiveness, spongy feeling brake pedal, pedal almost touches the floor, vehicle pulls to one side when braking
- Engine coolant temperature continually higher than normal (→P.78, 83)

If you notice any of these clues, take your vehicle to your Toyota dealer as soon as possible. Your vehicle may need adjustment or repair.

## Do-it-yourself service precautions

If you perform maintenance by yourself, be sure to follow the correct procedure as given in these sections.

## Maintenance

Items	Parts and tools
12-volt battery condition (→P.347)	<ul style="list-style-type: none"> <li>• Grease</li> <li>• Conventional wrench (for terminal clamp bolts)</li> </ul>
Engine/power control unit coolant level (→P.345)	<ul style="list-style-type: none"> <li>• “Toyota Super Long Life Coolant” or a similar high quality ethylene glycol-based non-silicate, non-amine, non-nitrite and non-borate coolant with long-life hybrid organic acid technology</li> <li>• “Toyota Super Long Life Coolant” is premixed with 50% coolant and 50% deionized water.</li> <li>• Funnel (used only for adding coolant)</li> </ul>
Engine oil level (→P.343)	<ul style="list-style-type: none"> <li>• “Toyota Genuine Motor Oil” or equivalent</li> <li>• Rag or paper towel</li> <li>• Funnel (used only for adding engine oil)</li> </ul>

Items	Parts and tools
Fuses (→P.365)	<ul style="list-style-type: none"> <li>• Fuse with same amperage rating as original</li> </ul>
Hybrid battery (traction battery) air intake vent (→P.355)	<ul style="list-style-type: none"> <li>• Vacuum cleaner, etc,</li> <li>• Phillips screwdriver</li> </ul>
Light bulbs (→P.367)	<ul style="list-style-type: none"> <li>• Bulb with same number and wattage rating as original</li> <li>• Phillips-head screwdriver</li> <li>• Flathead screwdriver</li> <li>• Wrench</li> </ul>
Radiator and condenser (→P.346)	—
Tire inflation pressure (→P.351)	<ul style="list-style-type: none"> <li>• Tire pressure gauge</li> <li>• Compressed air source</li> </ul>
Washer fluid (→P.346)	<ul style="list-style-type: none"> <li>• Water or washer fluid containing antifreeze (for winter use)</li> <li>• Funnel (used only for adding water or washer fluid)</li> </ul>



### WARNING

The engine compartment contains many mechanisms and fluids that may move suddenly, become hot, or become electrically energized. To avoid death or serious injury, observe the following precautions.

**WARNING****■ When working on the engine compartment**

- Make sure that “IGNITION ON” on the multi-information display and the “READY” indicator are both off.
- Keep hands, clothing and tools away from the moving fan.
- Be careful not to touch the engine, power control unit, radiator, exhaust manifold, etc. right after driving as they may be hot. Oil and other fluids may also be hot.
- Do not leave anything that may burn easily, such as paper and rags, in the engine compartment.
- Do not smoke, cause sparks or expose an open flame to fuel. Fuel fumes are flammable.
- Take care because brake fluid can harm your hands or eyes and damage painted surfaces. If fluid gets on your hands or in your eyes, flush the affected area with clean water immediately. If you still experience discomfort, consult a doctor.

**■ When working near the electric cooling fan or radiator grille**

Be sure the power switch is off. With the power switch in ON, the electric cooling fan may automatically start to run if the air conditioning is on and/or the coolant temperature is high. (→P.346)

**■ Safety glasses**

Wear safety glasses to prevent flying or falling material, fluid spray, etc., from getting in your eyes.

**NOTICE****■ If you remove the air cleaner filter**

Driving with the air cleaner filter removed may cause excessive engine wear due to dirt in the air.

**■ If the fluid level is low or high**

It is normal for the brake fluid level to go down slightly as the brake pads wear or when the fluid level in the accumulator is high. If the reservoir needs frequent refilling, it may indicate a serious problem.

## Hood

Release the lock from the inside of the vehicle to open the hood.

### Opening the hood

- 1 Pull the hood lock release lever.

The hood will pop up slightly.

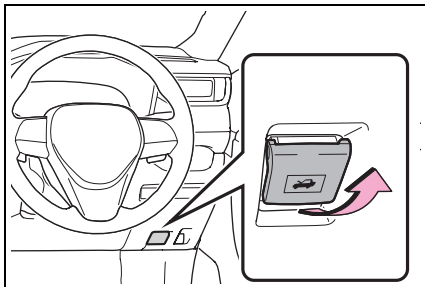

- 2 Push the auxiliary catch lever to the left and lift the hood.

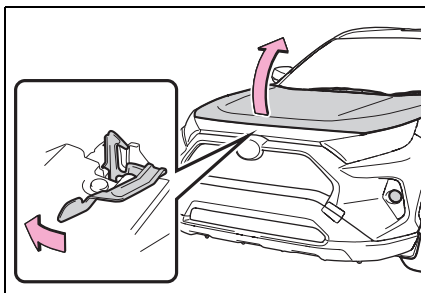

- 3 Hold the hood open by inserting the supporting rod into the slot.

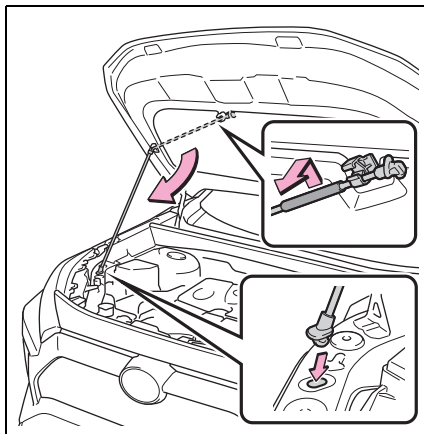

### ⚠ WARNING

#### ■ Pre-driving check

Check that the hood is fully closed and locked.

If the hood is not locked properly, it may open while the vehicle is in motion and cause an accident, which may result in death or serious injury.

#### ■ To prevent injuries

The support rod may be hot after driving the vehicle. Touching the hot support rod may lead to burns or other serious injuries.

#### ■ After installing the support rod into the slot

Make sure the rod supports the hood securely from falling down on to your head or body.

**WARNING**

■ **When closing the hood**

When closing the hood, take extra care to prevent your fingers etc. from being caught.

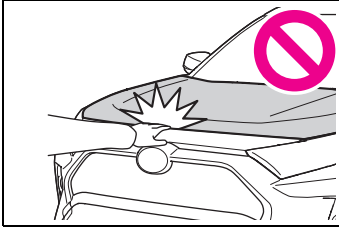
**NOTICE**

■ **When closing the hood**

Be sure to return the support rod to its clip before closing the hood. Closing the hood without returning the support rod properly could cause the hood to bend.

## Positioning a floor jack

When using a floor jack, follow the instructions in the manual provided with the jack and perform the operation safely.

When raising your vehicle with a floor jack, position the jack correctly.

Improper placement may damage your vehicle or cause injury.

## Location of the jack point

■ **Front**

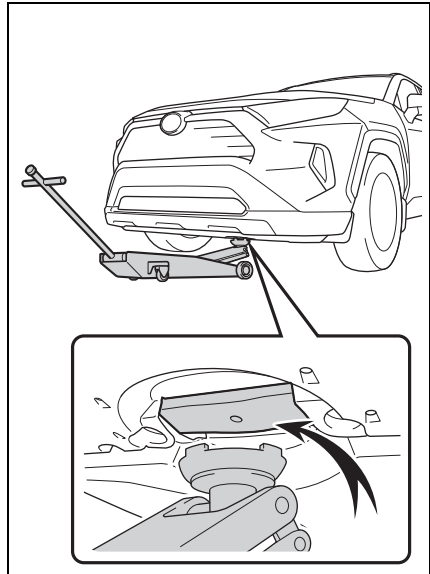

■ Rear

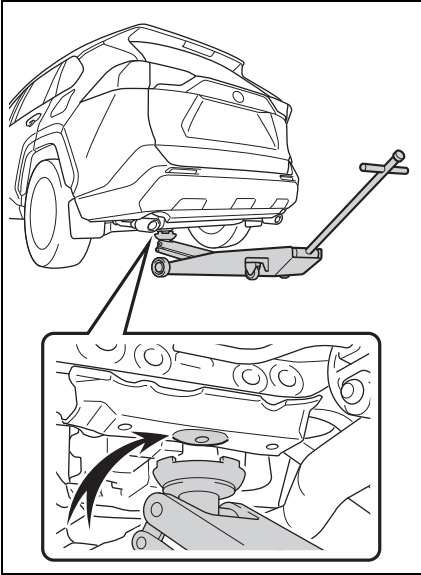

## Engine compartment

### Components

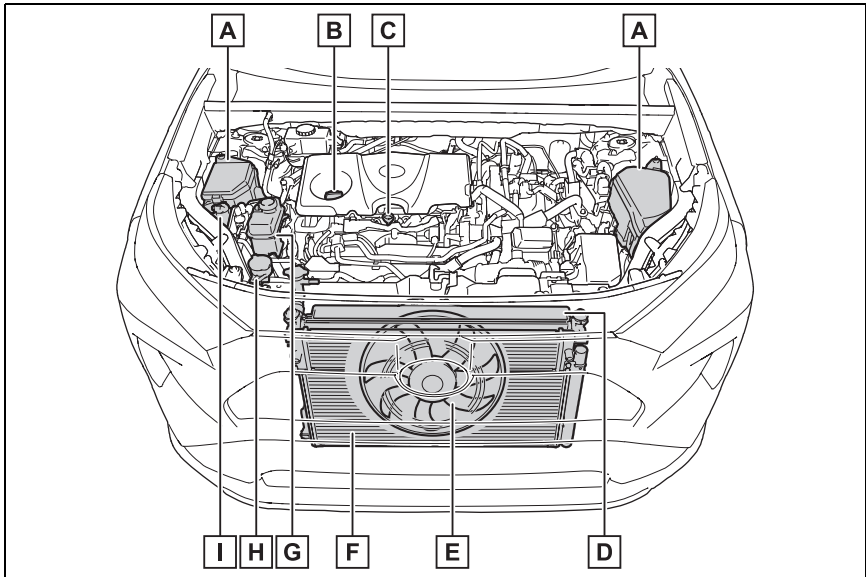

- A** Fuse boxes (→P.365)
- B** Engine oil filler cap (→P.344)
- C** Engine oil level dipstick (→P.343)
- D** Radiator (→P.346)
- E** Electric cooling fan
- F** Condenser (→P.346)
- G** Power control unit coolant reservoir (→P.345)
- H** Washer fluid tank (→P.346)
- I** Engine coolant reservoir (→P.345)

---

#### ■ 12-volt battery

→P.347



## Checking the engine oil

With the engine at operating temperature and turned off, check the oil level on the dipstick.

- 1 Park the vehicle on level ground. After warming up the engine and turning off the hybrid system, wait about 5 minutes for the oil to drain back into the bottom of the engine.
- 2 Holding a rag under the end, pull the dipstick out.

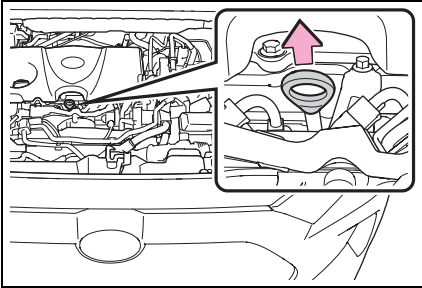

- 3 Wipe the dipstick clean.
- 4 Reinsert the dipstick fully.
- 5 Holding a rag under the end, pull the dipstick out and check whether the oil level is above low level mark.

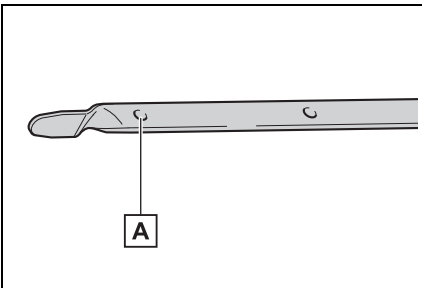

**A** Low level mark

The shape of the dipstick may differ depending on the type of vehicle or engine.

- 6 Wipe the dipstick and reinsert it fully.



### NOTICE

**To prevent serious engine damage**

Check the oil level on a regular basis.

### ■ Engine oil consumption

A certain amount of engine oil will be consumed while driving. In the following situations, oil consumption may increase, and engine oil may need to be refilled in between oil maintenance intervals.

- When the engine is new, for example directly after purchasing the vehicle or after replacing the engine
- If low quality oil or oil of an inappropriate viscosity is used
- When driving at high engine speeds or with a heavy load, when towing, or when driving while accelerating or decelerating frequently
- When leaving the engine idling for a long time, or when driving frequently through heavy traffic

### ■ Engine oil level rise

If the vehicle is repeatedly driven without the engine warmed up, moisture caused by dew condensation inside the engine or fuel which did not burn mixes into the engine oil, resulting in a rise in engine oil level. However, this is not a malfunction. For example, the engine become difficult to be warmed up in the following situations.

- When driving a short distance
  - When driving at a low speed
  - When the outside temperature is low
- When checking the engine oil, make sure that the engine is warmed up. If the

engine oil level exceeds the refill upper limit mark, contact your Toyota dealer.

## Adding engine oil

### ■ Checking the oil type and preparing the items needed

Make sure to check the oil type and prepare the items needed before adding oil.

- Engine oil selection

→P.422

- Oil quantity (Low level mark → Refill upper limit mark)

1.5 L (1.6 qt., 1.3 Imp. qt.)

- Item

Clean funnel

### ■ Adding engine oil

If the oil level is below or near the low level mark, add engine oil of the same type as that already in the engine.

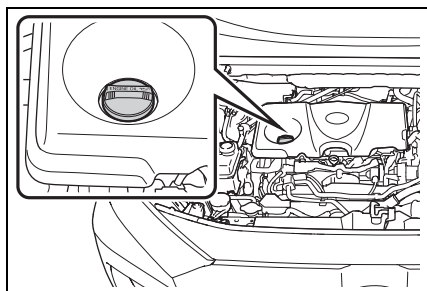

- 1 Remove the oil filler cap by turning it counterclockwise.
- 2 Add engine oil slowly, checking the dipstick.

Make sure that the oil level does not exceed the refill upper limit mark and is between the low level mark and refill

upper limit mark.

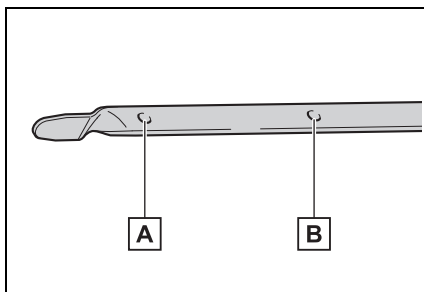

**A** Low level mark

**B** Refill upper limit mark

The shape of the dipstick may differ depending on the type of vehicle or engine.

- 3 Install the oil filler cap by turning it clockwise.

### ⚠ WARNING

#### ■ Used engine oil

- Used engine oil contains potentially harmful contaminants which may cause skin disorders such as inflammation and skin cancer, so care should be taken to avoid prolonged and repeated contact. To remove used engine oil from your skin, wash thoroughly with soap and water.
- Dispose of used oil and filters only in a safe and acceptable manner. Do not dispose of used oil and filters in household trash, in sewers or onto the ground. Call your Toyota dealer, service station or auto parts store for information concerning recycling or disposal.
- Do not leave used engine oil within the reach of children.

**NOTICE**

■ **When replacing the engine oil**

- Be careful not to spill engine oil on the vehicle components.
- Avoid overfilling, or the engine could be damaged.
- Check the oil level on the dipstick every time you refill the vehicle.
- Be sure the engine oil filler cap is properly tightened.

■ **If oil is spilled on the engine cover**

To prevent the engine cover from being damaged, remove any engine oil from the engine cover as soon as possible using a neutral detergent. Do not use an organic solvent such as brake cleaner.

### Checking the coolant

The coolant level is satisfactory if it is between the “FULL” and “LOW” lines on the reservoir when the hybrid system is cold.

■ **Engine coolant reservoir**

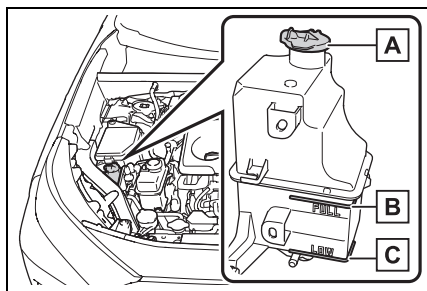

**A** Reservoir cap

**B** “FULL” line

**C** “LOW” line

If the level is on or below the “LOW”

line, add coolant up to the “FULL” line.  
(→P.413)

■ **Power control unit coolant reservoir**

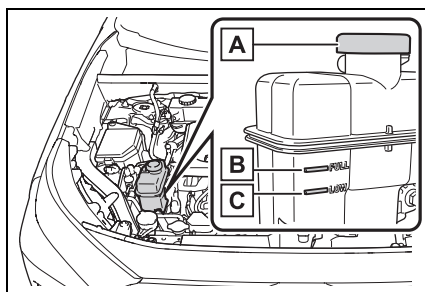

**A** Reservoir cap

**B** “FULL” line

**C** “LOW” line

If the level is on or below the “LOW” line, add coolant up to the “FULL” line.  
(→P.414)

■ **Coolant selection**

Only use “Toyota Super Long Life Coolant” or a similar high quality ethylene glycol based non-silicate, non-amine, non-nitrite, and non-borate coolant with long-life hybrid organic acid technology. “Toyota Super Long Life Coolant” is a mixture of 50% coolant and 50% deionized water. (Minimum temperature: -35°C [-31°F])

For more details about coolant, contact your Toyota dealer.

■ **If the coolant level drops within a short time of replenishing**

Visually check the radiators, hoses, engine/power control unit coolant reservoir caps, drain cock and water pump. If you cannot find a leak, have your Toyota dealer, test the cap and check for leaks in the cooling system.

**WARNING****■ When the hybrid system is hot**

Do not remove the engine/power control unit coolant reservoir caps.

The cooling system may be under pressure and may spray hot coolant if the cap is removed, causing serious injuries, such as burns.

**NOTICE****■ When adding coolant**

Coolant is neither plain water nor straight antifreeze. The correct mixture of water and antifreeze must be used to provide proper lubrication, corrosion protection and cooling. Be sure to read the antifreeze or coolant label.

**■ If you spill coolant**

Be sure to wash it off with water to prevent it from damaging parts or paint.

**Checking the radiator and condenser**

Check the radiator and condenser, and clear away any foreign objects. If either of the above parts is extremely dirty or you are not sure of their condition, have your vehicle inspected by your Toyota dealer.

**WARNING****■ When the hybrid system is hot**

Do not touch the radiator or condenser as they may be hot and cause serious injuries, such as burns.

**■ When the electric cooling fan is operating**

Do not touch the engine compartment.

With the power switch in ON, the electric cooling fan may automatically start to run if the air conditioning is on and/or the coolant temperature is high. Be sure the power switch is off when working near the electric cooling fan or radiator grille.

**Checking and adding the washer fluid**

If the washer fluid level is at “LOW”, add washer fluid.

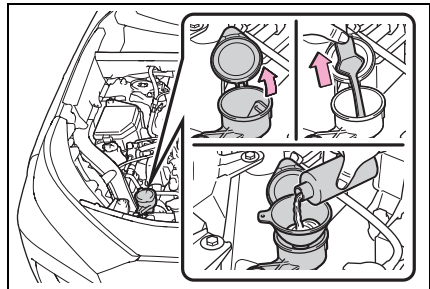
**■ Using the gauge**

The washer fluid level can be checked by observing the position of the level on the liquid-covered holes in the gauge.

If the level falls below the second hole from the bottom (the “LOW” position), refill the washer fluid.

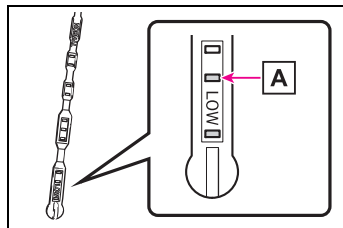

**A** Current fluid level

**WARNING****■ When adding washer fluid**

Do not add washer fluid when the hybrid system is hot or operating as washer fluid contains alcohol and may catch fire if spilled on the hybrid system, etc.

**NOTICE****■ Do not use any fluid other than washer fluid**

Do not use soapy water or engine antifreeze instead of washer fluid. Doing so may cause streaking on the vehicle's painted surfaces, as well as damaging the pump leading to problems of the washer fluid not spraying.

**■ Diluting washer fluid**

Dilute washer fluid with water as necessary.

Refer to the freezing temperatures listed on the label of the washer fluid bottle.

**12-volt battery****Location**

The 12-volt battery is located in the right-hand side of luggage compartment.

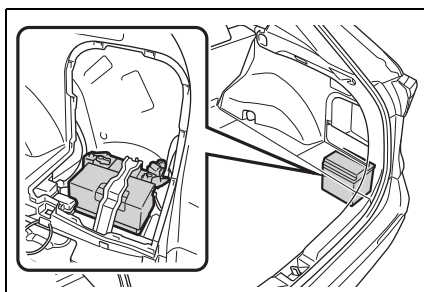
**■ Before recharging**

When recharging, the 12-volt battery produces hydrogen gas which is flammable and explosive. Therefore, observe the following precautions before recharging:

- If recharging with the 12-volt battery installed on the vehicle, be sure to disconnect the ground cable.
- Make sure the power switch on the charger is off when connecting and disconnecting the charger cables to the 12-volt battery.

**■ After recharging/reconnecting the 12-volt battery**

- Unlocking the doors using the smart entry & start system may not be possible immediately after reconnecting the 12-volt battery. If this happens, use the wireless remote control or the mechanical key to lock/unlock the doors.
- Start the hybrid system with the power switch in ACC. The hybrid system may not start with the power switch turned off. However, the hybrid system will operate normally from the second attempt.

- The power switch mode is recorded by the vehicle. If the 12-volt battery is reconnected, the vehicle will return the power switch mode to the status it was in before the 12-volt battery was disconnected. Make sure to turn off the power switch before disconnect the 12-volt battery. Take extra care when connecting the 12-volt battery if the power switch mode prior to discharge is unknown.

If the hybrid system will not start even after multiple attempts at all methods above, contact your Toyota dealer.



### WARNING

#### ■ Chemicals in the 12-volt battery

The 12-volt battery contains poisonous and corrosive sulfuric acid and may produce hydrogen gas which is flammable and explosive. To reduce the risk of death or serious injury, take the following precautions while working on or near the 12-volt battery:

- Do not cause sparks by touching the 12-volt battery terminals with tools.
- Do not smoke or light a match near the 12-volt battery.
- Avoid contact with eyes, skin and clothes.
- Never inhale or swallow electrolyte.
- Wear protective safety glasses when working near the 12-volt battery.
- Keep children away from the 12-volt battery.

#### ■ Where to safely charge the 12-volt battery

Always charge the 12-volt battery in an open area. Do not charge the 12-volt battery in a garage or closed room where there is not sufficient ventilation.

#### ■ Emergency measures regarding electrolyte

- If electrolyte gets in your eyes  
Flush your eyes with clean water for at least 15 minutes and get immediate medical attention. If possible, continue to apply water with a sponge or cloth while traveling to the nearest medical facility.
- If electrolyte gets on your skin  
Wash the affected area thoroughly. If you feel pain or burning, get medical attention immediately.
- If electrolyte gets on your clothes  
It can soak through clothing on to your skin. Immediately take off the clothing and follow the procedure above if necessary.
- If you accidentally swallow electrolyte  
Drink a large quantity of water or milk. Get emergency medical attention immediately.

#### ■ When there is insufficient 12-volt battery fluid

Do not use if there is insufficient fluid in the 12-volt battery. There is a possible danger that the 12-volt battery may explode.



### NOTICE

#### ■ When recharging the 12-volt battery

Never recharge the 12-volt battery while the hybrid system is operating. Also, be sure all accessories are turned off.

### Removing the 12-volt battery cover

- 1 Open the deck board (→P.312)

- 2 Disengage the 12 claws and pull the luggage side cover to remove it.

When installing the luggage side cover, make sure that the claws are installed securely.

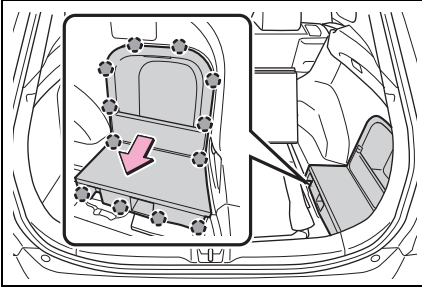

## Exterior

Make sure that the 12-volt battery terminals are not corroded and that there are no loose connections, cracks, or loose clamps.

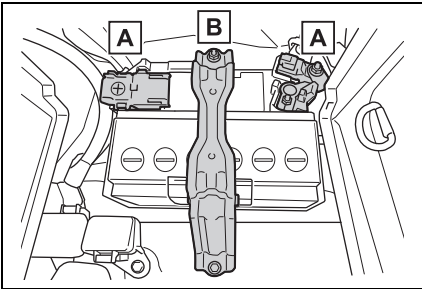

**A** Terminals

**B** Hold-down clamp

## Tires

Replace or rotate tires in accordance with maintenance schedules and treadwear.

## Checking tires

Check if the treadwear indicators are showing on the tires. Also check the tires for uneven wear, such as excessive wear on one side of the tread.

Check the spare tire condition and pressure if not rotated.

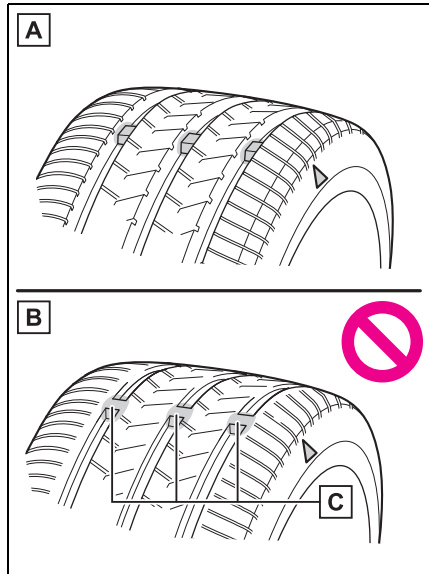

**A** New tread

**B** Worn tread

**C** Treadwear indicator

The location of treadwear indicators is shown by a "TWI" or "△" mark, etc.,

molded into the sidewall of each tire. Replace the tires if the treadwear indicators are showing on a tire.

### ■ When to replace your vehicle's tires

Tires should be replaced if:

- The treadwear indicators are showing on a tire.
- You have tire damage such as cuts, splits, cracks deep enough to expose the fabric, and bulges indicating internal damage.
- A tire goes flat repeatedly or cannot be properly repaired due to the size or location of a cut or other damage.

If you are not sure, consult with your Toyota dealer.

### ■ Tire life

Any tire over 6 years old must be checked by a qualified technician even if it has seldom or never been used or damage is not obvious.

### ■ If the tread on snow tires wears down below 4 mm (0.16 in.)

The effectiveness of the tires as snow tires is lost.



### WARNING

#### ■ When inspecting or replacing tires

Observe the following precautions to prevent accidents.

Failure to do so may cause damage to parts of the drive train as well as dangerous handling characteristics, which may lead to an accident resulting in death or serious injury.

- Do not mix tires of different makes, models or tread patterns. Also, do not mix tires of remarkably different treadwear.
- Do not use tire sizes other than those recommended by Toyota.

- Do not mix differently constructed tires (radial, bias-belted or bias-ply tires).

- Do not mix summer, all season and snow tires.

- Do not use tires that have been used on another vehicle. Do not use tires if you do not know how they were used previously.

- Vehicles with compact spare tire: Do not tow if your vehicle has a compact spare tire installed.



### NOTICE

#### ■ Driving on rough roads

Take particular care when driving on roads with loose surfaces or potholes. These conditions may cause losses in tire inflation pressure, reducing the cushioning ability of the tires. In addition, driving on rough roads may cause damage to the tires themselves, as well as the vehicle's wheels and body.

#### ■ If tire inflation pressure of each tire becomes low while driving

Do not continue driving, or your tires and/or wheels may be ruined.

### Tire rotation

Rotate the tires in the order shown.

2WD models:

To equalize tire wear and help extend tire life, Toyota recommends that tire rotation is carried out approximately every 10000 km (6000 miles).

AWD models:

To equalize tire wear and help extend tire life, Toyota recommends that tire rotation is carried out approximately every 5000 km (3000 miles).



- ▶ Vehicles without full-size spare tire

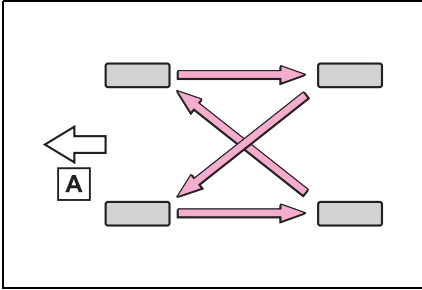

**A** Front

- ▶ Vehicles with full-size spare tire

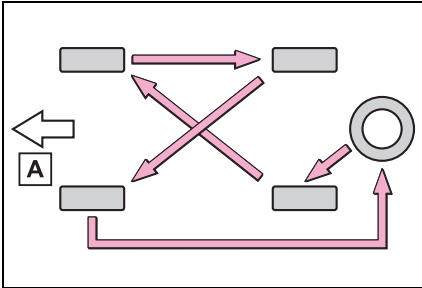

**A** Front

## Tire inflation pressure

**Make sure to maintain the proper tire inflation pressure. Tire inflation pressure should be checked at least once per month. However, Toyota recommends that tire inflation pressure be checked once every two weeks. (→P.426)**

### ■ Effects of incorrect tire inflation pressure

Driving with incorrect tire inflation pressure may result in the following:

- Reduced fuel economy
- Reduced driving comfort and poor handling
- Reduced tire life due to wear
- Reduced safety
- Damage to the drive train

If a tire needs frequent inflating, have it checked by your Toyota dealer.

### ■ Instructions for checking tire inflation pressure

When checking tire inflation pressure, observe the following:

- Check only when the tires are cold. If your vehicle has been parked for at least 3 hours or has not been driven for more than 1.5 km or 1 mile, you will get an accurate cold tire inflation pressure reading.
- Always use a tire pressure gauge. It is difficult to judge if a tire is properly inflated based only on its appearance.
- It is normal for the tire inflation pressure to be higher after driving as heat is generated in the tire. Do not reduce tire inflation pressure after driving.
- Passengers and luggage weight should be placed so that the vehicle is balanced.

**WARNING****■ Proper inflation is critical to save tire performance**

Keep your tires properly inflated. If the tires are not properly inflated, the following conditions may occur which could lead to an accident resulting in death or serious injury:

- Excessive wear
- Uneven wear
- Poor handling
- Possibility of blowouts resulting from overheated tires
- Air leaking from between tire and wheel
- Wheel deformation and/or tire damage
- Greater possibility of tire damage while driving (due to road hazards, expansion joints, sharp edges in the road, etc.)

**NOTICE****■ When inspecting and adjusting tire inflation pressure**

Be sure to put the tire valve caps back on.

If a valve cap is not installed, dirt or moisture may get into the valve and cause an air leak, resulting in decreased tire inflation pressure.

**Wheels**

**If a wheel is bent, cracked or heavily corroded, it should be replaced. Otherwise, the tire may separate from the wheel or cause a loss of handling control.**

**Wheel selection**

When replacing wheels, care should be taken to ensure that they are equivalent to those removed in load capacity, diameter, rim width and inset\*.

Replacement wheels are available at your Toyota dealer.

\*: Conventionally referred to as offset.

Toyota does not recommend using the following:

- Wheels of different sizes or types
- Used wheels
- Bent wheels that have been straightened

**WARNING****■ When replacing wheels**

- Do not use wheels that are a different size from those recommended in the Owner's Manual, as this may result in a loss of handling control.
- Never use an inner tube in a leaking wheel which is designed for a tubeless tire. Doing so may result in an accident, causing death or serious injury.

## ⚠ WARNING

### ■ When installing the wheel nuts

Never use oil or grease on the wheel bolts or wheel nuts. Oil and grease may cause the wheel nuts to be excessively tightened, leading to bolt or disc wheel damage. In addition, the oil or grease can cause the wheel nuts to loosen and the wheel may fall off, causing an accident and resulting in death or serious injury. Remove any oil or grease from the wheel bolts or wheel nuts.

### ■ Use of defective wheels prohibited

Do not use cracked or deformed wheels.

Doing so could cause the tire to leak air during driving, possibly causing an accident.

## Aluminum wheel precautions

- Use only Toyota wheel nuts and wrenches designed for use with your aluminum wheels.
- When rotating, repairing or changing your tires, check that the wheel nuts are still tight after driving 1600 km (1000 miles).
- Be careful not to damage the aluminum wheels when using tire chains.
- Use only Toyota genuine balance weights or equivalent and a plastic or rubber hammer when balancing your wheels.

## Air conditioning filter

The air conditioning filter must be changed regularly to maintain air conditioning efficiency.

### Removal method

- 1 Turn the power switch to OFF.
- 2 Open the glove box and slide off the damper.

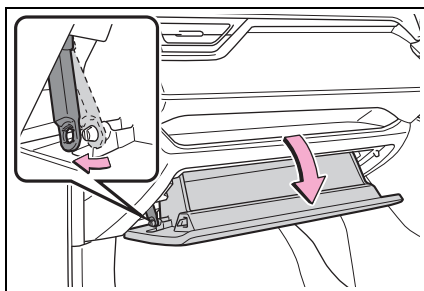

- 3 Push in each side of the glove box to disconnect the claws, and then slowly and fully open the glove box while supporting it.

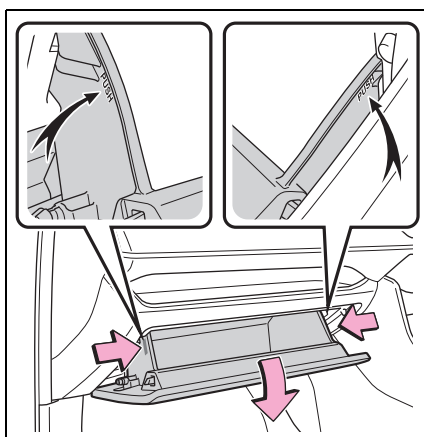

- 4 With the glove box fully open, slightly lift up the glove box and

pull toward the seat to detach the bottom of the glove box.

Do not use excessive force if the glove box does not detach when lightly pulled. Instead, pull toward the seat while slightly adjusting the height of the glove box.

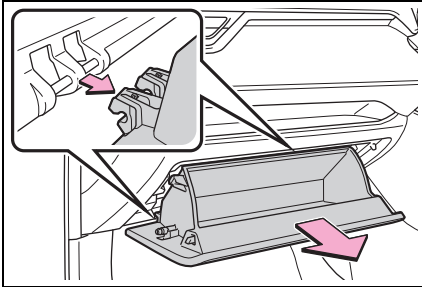

- 5 Unlock the filter cover (A), pull the filter cover out of the claws (B), and remove the filter cover.

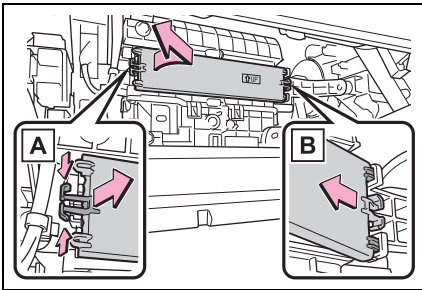

- 6 Remove the air conditioning filter and replace it with a new one.

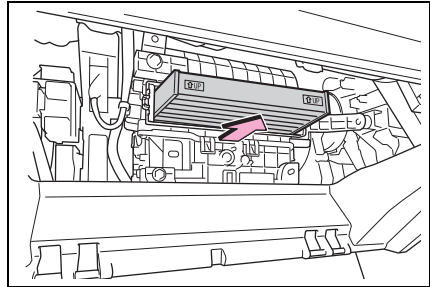

- 7 When installing, reverse the steps listed.

#### ■ Checking interval

Inspect and replace the air conditioning filter according to the maintenance schedule. In dusty areas or areas with heavy traffic flow, early replacement may be required. (For scheduled maintenance information, please refer to the "Warranty and Service Booklet")

#### ■ If air flow from the vents decreases dramatically

The filter may be clogged. Check the filter and replace if necessary.

#### ⚠ NOTICE

##### ■ When using the air conditioning system

Make sure that a filter is always installed.

Using the air conditioning system without a filter may cause damage to the system.

##### ■ When removing the glove box

Always follow the specified procedure to remove the glove box (→P.353). If the glove box is removed without following the specified procedure, the hinge of the glove box may become damaged.



## NOTICE

■ **To prevent damage to the filter cover**

When moving the filter cover in the direction of arrow to release the fitting, pay attention not to apply excessive force to the claws. Otherwise, the claws may be damaged.

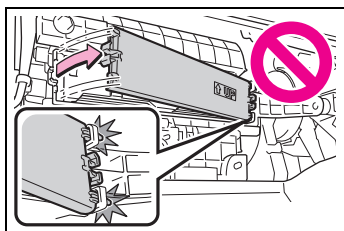

## Cleaning the hybrid battery (traction battery) air intake vent

**To prevent the fuel economy from being affected, visually inspect the hybrid battery (traction battery) air intake vent periodically for clogs.**

**If it is dusty or clogged or if “Maintenance Required for Traction Battery Cooling Parts See Owner’s Manual” is displayed on the multi-information display, clean the air intake vent using the following procedures:**

■ **Scheduled maintenance of the air intake vent is necessary when**

In some situations such as when the vehicle is used frequently or in heavy traffic or dusty areas, the air intake vent may need to be cleaned more regularly. (For scheduled maintenance information, please refer to the “Warranty and Service Booklet”)

■ **Cleaning the air intake vent**

Improper handling of the air intake vent cover and filter may result in damage to them. If you have any concerns about cleaning the filter, contact your Toyota dealer.



## NOTICE

■ If “Maintenance Required for Traction Battery Cooling Parts See Owner’s Manual” is displayed on the multi-information display

Clean the air intake vent immediately. If the vehicle is continuously driven with the warning message displayed, it may cause a malfunction or output restriction of the hybrid battery (traction battery).

### Cleaning procedure

- 1 Turn the power switch off.
- 2 Using a Phillips screwdriver, remove the clip.

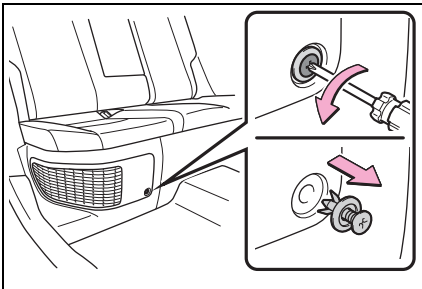

- 3 Remove the air intake vent cover.

Pull the right corner of the air intake vent cover, remove the claws in the 8 locations shown in the illustration and pull the air intake vent cover to the front

of the vehicle to remove it.

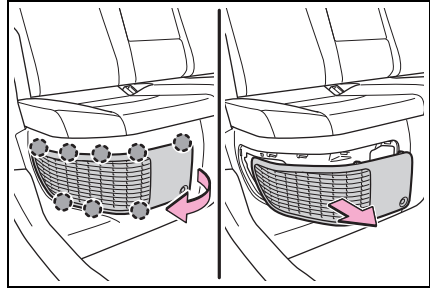

- 4 Remove the filter from the air intake vent cover.

Detach the claws in the order of the center (4 locations), **A** and **B**.

If dust has accumulated on the air intake vent cover, remove the dust with a vacuum cleaner, etc.

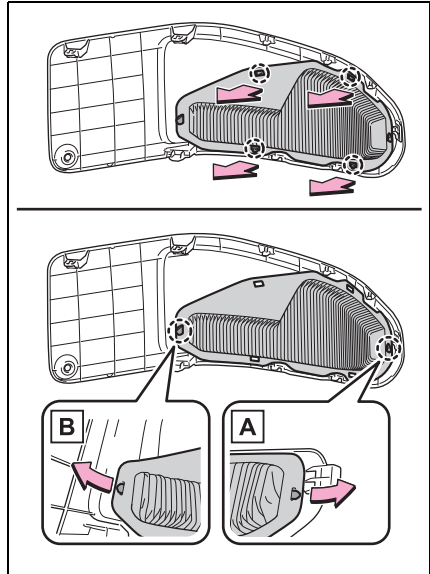

- 5 Remove the dust and sand from the filter.

Using a vacuum cleaner, etc., absorb dust and sand from the filter by profiling

the nozzle lightly along the fold.

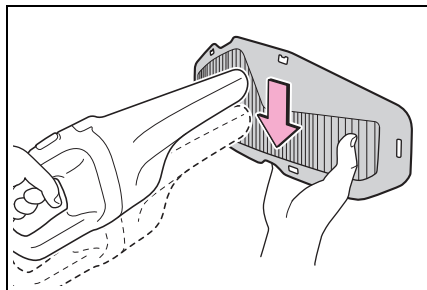

- 6** Hold the filter to the light and check if it is not clogged.

If the dust or sand cannot be removed completely, contact your Toyota dealer.

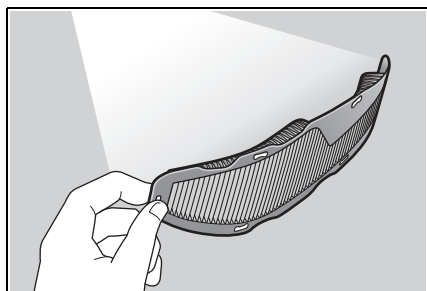

- 7** Reinstall the filter to the cover.

Attach the claws to the air intake cover in the order of **B**, **A** and the center (4 locations).

Make sure that the filter is not crooked

or deformed when installing it.

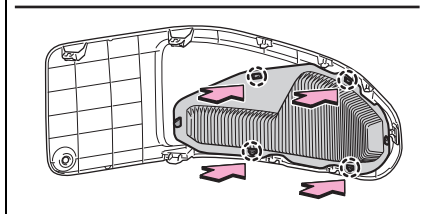
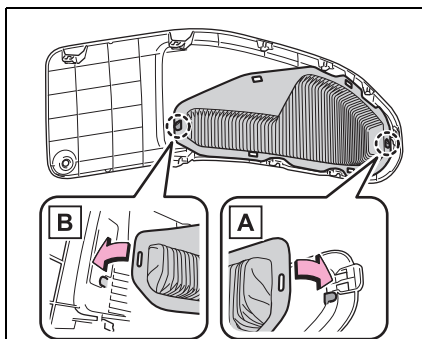

- 8** Install the air intake vent cover.

Insert the claw of the left corner of the air intake vent cover, and then attach the claws in the 8 locations shown in the illustration.

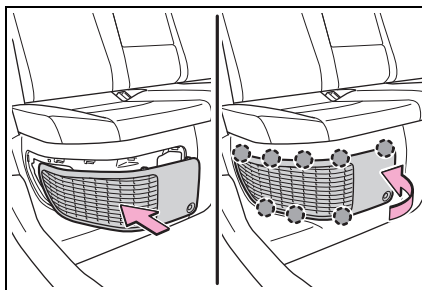

## 9 Install the clip.

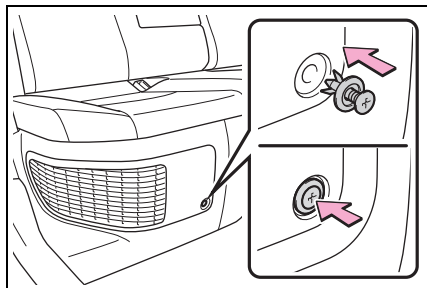

- ▶ If “Maintenance Required for Traction Battery Cooling Parts See Owner’s Manual” was displayed on the multi-information display

## 10 Start the hybrid system and check that the warning message is no longer displayed.

It may be necessary to drive the vehicle for approximately 20 minutes before the warning message is displayed again then disappears.

If the warning message does not disappear after some time, have the vehicle inspected by your Toyota dealer.

### ■ If the dust or sand on the filter cannot be removed

It is recommended to use a vacuum cleaner with plastic brushes.



### WARNING

#### ■ When cleaning the air intake vent

- Do not use water or other liquids to clean the air intake vent. If water is applied to the hybrid battery (traction battery) or other components, a malfunction or fire may occur.
- Do not touch the service plug located near the air intake vent. (→P.64)

- Before cleaning the air intake vent, make sure to turn the power switch off to stop the hybrid system.
- Do not put a hand or leg in the air intake vent. If it is caught in a cooling fan, or if it touches a high voltage part that results in an electric shock, death or serious injuries may result.



### NOTICE

#### ■ When cleaning the air intake vent

Do not use an air blow gun, etc.

Dust may be blown out, possibly causing a malfunction or output restriction of the hybrid battery (traction battery).

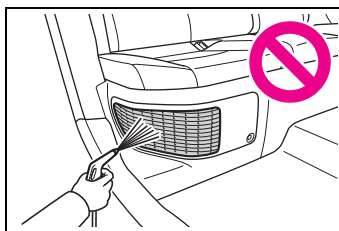

#### ■ To prevent damage to the vehicle

Observe the following precautions:

- Do not allow water or foreign matter to enter the air intake vent.
- Make sure to reinstall the filter and cover to their original positions after cleaning.
- Do not install anything to the air intake vent other than the exclusive filter for this vehicle or use the vehicle without the filter installed.

#### ■ To prevent damage to the filter

Observe the following precautions.

If the filter is damaged, have it replaced with a new filter by your Toyota dealer.

- Do not use an air blow gun, etc.



**NOTICE**

- Do not press hard a vacuum cleaner, etc. against the filter.
- Do not use a hard brush, such as a metal brush.
- Do not break the fold of the filter.

## Wiper insert replacement

When replacing the wiper insert, perform the following procedure to operate each wiper.

### Windshield wipers

#### ■ Windshield wiper blade removal and installation

- 1 While holding the hook portion **A** of the wiper arm, first lift up the driver side, and then lift up the passenger side.

When returning the wiper arms to their original positions, first lower the passenger side, and then lower the driver side.

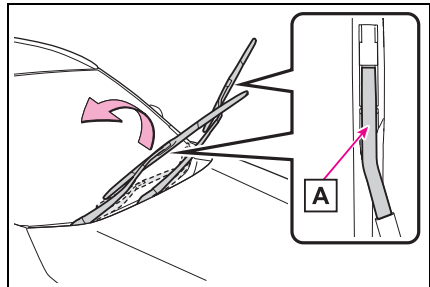

- 2 Lift the stopper using a flat-head screwdriver as shown in the illustration.

To prevent damage to the wiper arm, protect the tip of the screwdriver with a

rag.

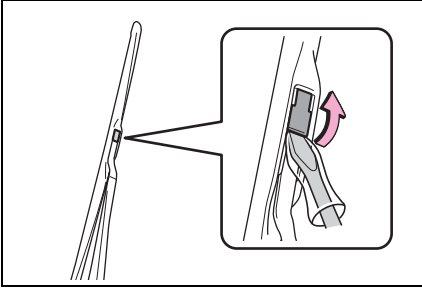

- 3** Slide the wiper blade to remove it from the wiper arm.

When installing, reverse the steps listed.

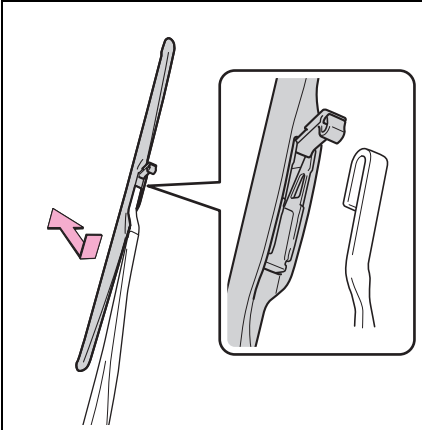

### ■ Wiper insert replacement

- 1** Pull the wiper insert to remove the claw of the wiper blade from

the stopper, and pull out the wiper insert.

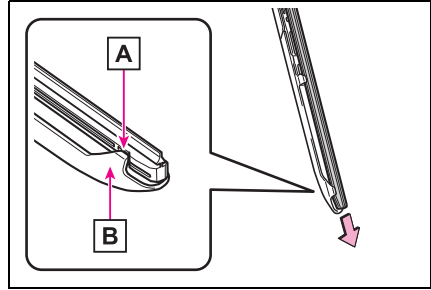

**A** Stopper

**B** Claw

- 2** Remove the 2 metal plates from the wiper insert pulled out, and install the plates to a new wiper insert.

Make sure that the cutout location and warp direction of the metal blades are same as the original.

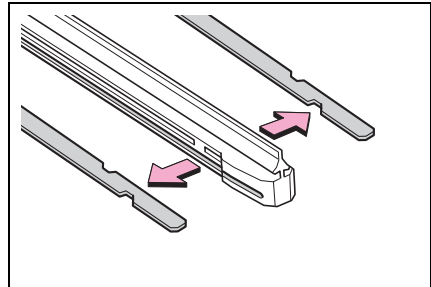

- 3** Install the wiper insert to the wiper blade from the side without the stopper.
- 4** Secure the stopper of the wiper insert with the claw of the wiper blade.

## Rear window wiper

- 1 Move the wiper blade until a click sound can be heard and the claw detaches, and then remove the wiper blade from the wiper arm.

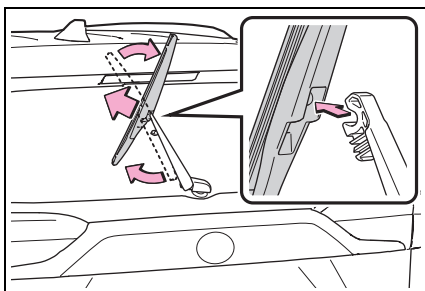

- 2 Pull the wiper insert out past the stopper on the wiper blade, and then continue to pull until it is completely removed.

Lightly grasp between the claws of the wiper blade to allow the wiper insert to lift up, making it easier to remove.

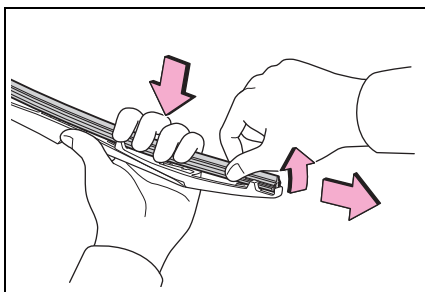

- 3 Remove the 2 metal plates from the old wiper insert and install

them to the replacement wiper insert.

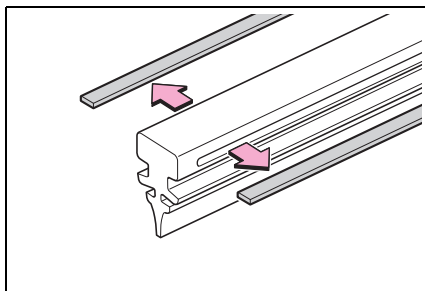

- 4 Insert the wiper insert starting from the claw at the center of the wiper blade. Pass the wiper insert through the 3 claws so that it sticks out from the stopper, and then pass the wiper insert through the final remaining claw.

Applying a small amount of washer fluid to the wiper insert can make it easier to insert the claws into the grooves.

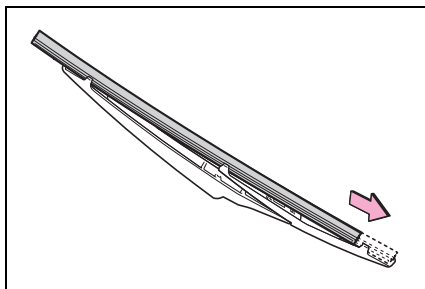

- 5 Check that the wiper blade claws are fitted in the grooves of the wiper insert.

If the wiper blade claws are not fitted in the grooves of the wiper insert, grasp the wiper insert and slide it back and forth multiple times to insert the claws into the grooves.

Lightly lift up the center of the wiper insert to make the rubber easier to

slide.

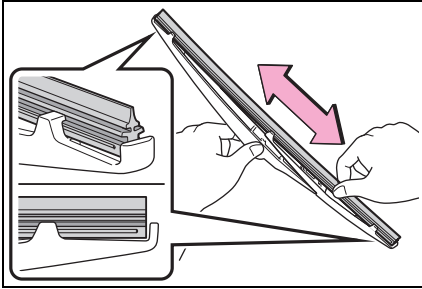

- 6** When installing a wiper blade, reverse the procedure in step **1**.

After installing the wiper blade, check that the connection is locked.

#### ■ Wiper blade and wiper insert handling

Improper handling may result in damage to the wiper blades or wiper insert. If you have any concerns about replacing the wiper blades or wiper insert yourself, contact your Toyota dealer.



#### NOTICE

##### ■ When lifting the windshield wipers

- When raising the wiper arms off the windshield, lift up the driver side first, and then lift up passenger side. When returning the wipers to their original position, return the passenger side first.
- Do not lift a windshield wiper by the wiper blade. Otherwise, the wiper blade may be deformed.
- Do not operate the wiper lever when the windshield wipers are lifted. Otherwise, the windshield wipers may contact the hood, possibly resulting in damage to the windshield wipers and/or hood.

##### ■ To prevent damage

- Be careful not to damage the claws when replacing the wiper insert.

- After the wiper blade is removed from the wiper arm, place a cloth, etc., between the rear window and wiper arm to prevent damage to the rear window.
- Be sure not to pull excessively on the wiper insert or deform its metal plates.

## Electronic key battery

Replace the battery with a new one if it is depleted.

### ■ If the key battery is depleted

The following symptoms may occur:

- The smart entry & start system and wireless remote control will not function properly.
- The operational range will be reduced.

## Items to prepare

Prepare the following before replacing the battery:

- Flathead screwdriver
- Small flathead screwdriver
- Lithium battery CR2032

### ■ Use a CR2032 lithium battery

- Batteries can be purchased at your Toyota dealer, local electrical appliance shops or camera stores.
- Replace only with the same or equivalent type recommended by the manufacturer.
- Dispose of used batteries according to the local laws.

## Replacing the battery

- 1 Release the lock and remove the mechanical key.

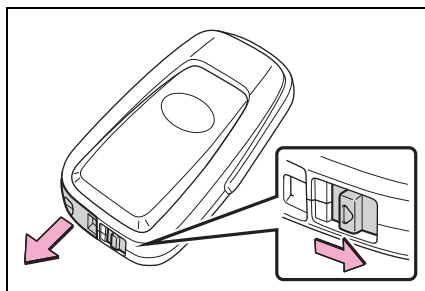

- 2 Remove the key cover.

Use a screwdriver of an appropriate size. Forcedly prying may cause the cover damaged.

To prevent damage to the key, cover the tip of the flathead screwdriver with a rag.

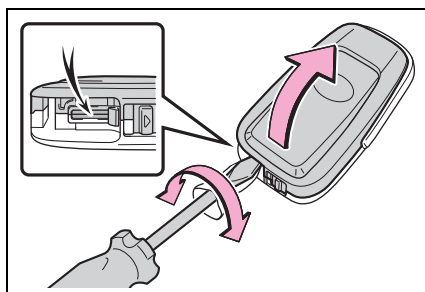

- 3 Remove the depleted battery using a small flathead screwdriver.

When removing the cover, the electronic key module may stick to the cover and the battery may not be visible. In this case, remove the electronic key module in order to remove the battery.

When removing the battery, use a screwdriver of an appropriate size.

Insert a new battery with the “+” termi-

nal facing up.

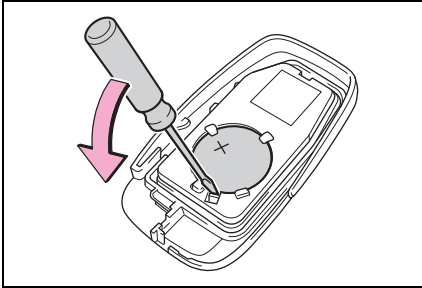

- 4 When installing, reverse the steps listed.



### WARNING

#### ■ Battery precautions

Observe the following precautions. Failure to do so may result in death or serious injury.

- Do not swallow the battery. Doing so may cause chemical burns.
- A coin battery or button battery is used in the electronic key. If a battery is swallowed, it may cause severe chemical burns in as little as 2 hours and may result in death or serious injury.
- Keep away new and removed batteries from children.
- If the cover cannot be firmly closed, stop using the electronic key and stow the key in the place where children cannot reach, and then contact your Toyota dealer.
- If you accidentally swallow a battery or put a battery into a part of your body, get emergency medical attention immediately.

#### ■ To prevent battery explosion or leakage of flammable liquid or gas

- Replace the battery with a new battery of the same type. If a wrong type of battery is used, it may explode.

- Do not expose batteries to extremely low pressure due to high altitude or extremely high temperatures.
- Do not burn, break or cut a battery.



### NOTICE

#### ■ For normal operation after replacing the battery

Observe the following precautions to prevent accidents:

- Always work with dry hands. Moisture may cause the battery to rust.
- Do not touch or move any other component inside the remote control.
- Do not bend either of the battery terminals.

## Checking and replacing fuses

If any of the electrical components do not operate, a fuse may have blown. If this happens, check and replace the fuses as necessary.

## Checking and replacing fuses

- 1 Turn the power switch to OFF.
  - 2 Open the fuse box cover.
- ▶ Engine compartment: Type A fuse box

Push claws **A** and **B** to completely release the lock, and then lift up the cover.

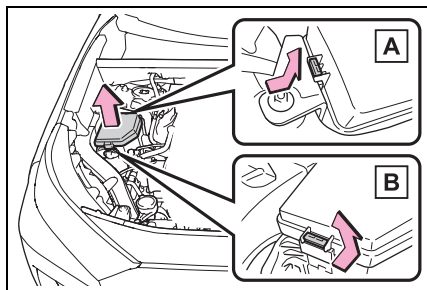

- ▶ Engine compartment: Type B fuse box

Push claws **A** and **B** to completely release the lock, and then lift up the cover.

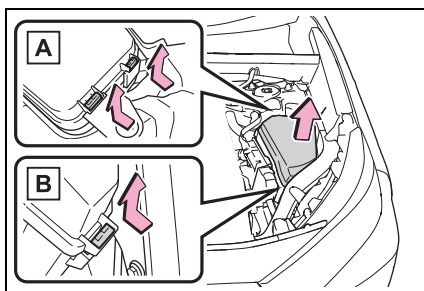

- ▶ Left side instrument panel

Push the tab in and remove the cover, and then remove the lid.

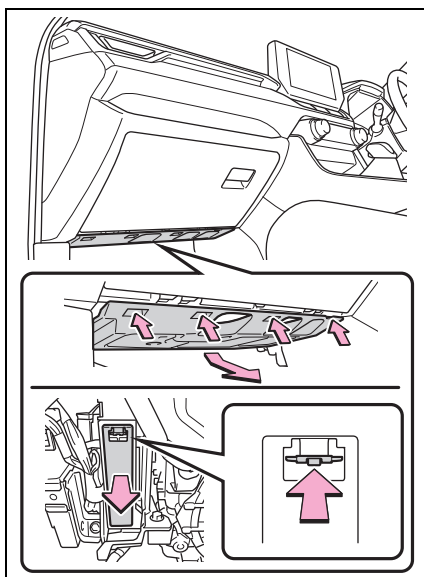

- ▶ Right side luggage compartment

Open the deck board. (→P.312)

Disengage the 12 claws and pull the luggage side cover to remove it.

When installing the luggage side cover, make sure that the claws are installed securely.

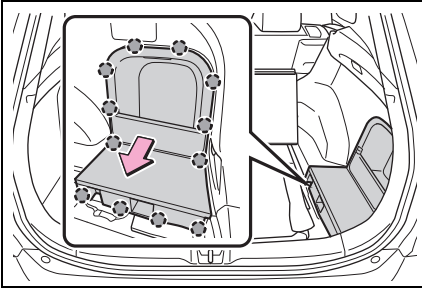

Remove the cover

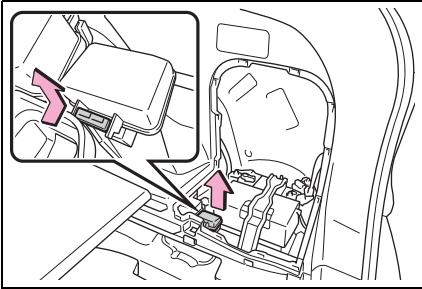

**3** Remove the fuse.

Only type A fuse can be removed using the pullout tool.

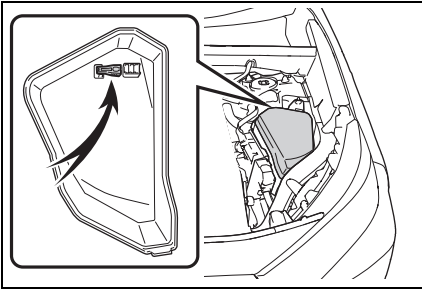

**4** Check if the fuse is blown.

Replace the blown fuse with a new fuse of an appropriate amperage rating. The amperage rating can be found on the fuse box lid.

► Type A

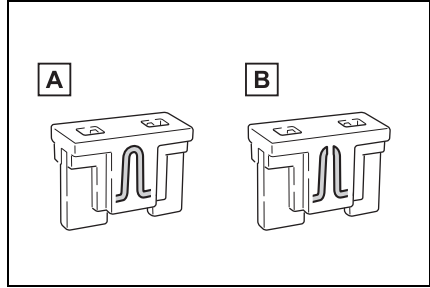

**A** Normal fuse

**B** Blown fuse

► Type B

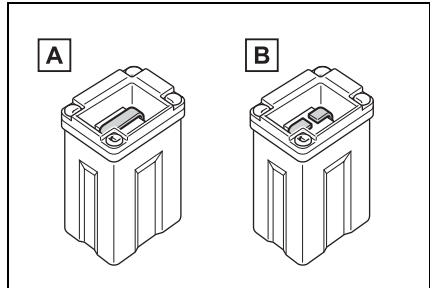

**A** Normal fuse

**B** Blown fuse

► Type C

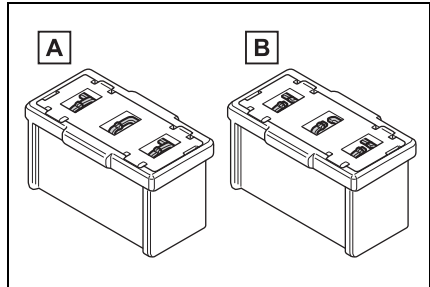

**A** Normal fuse

**B** Blown fuse



### ■ After a fuse is replaced

- When installing the lid, make sure that the tab is installed securely.
- If the lights do not turn on even after the fuse has been replaced, a bulb may need replacement. (→P.367)
- If the replaced fuse blows again, have the vehicle inspected by your Toyota dealer.

### ■ If there is an overload in a circuit

The fuses are designed to blow, protecting the wiring harness from damage.



### WARNING

#### ■ To prevent system breakdowns and vehicle fire

Observe the following precautions. Failure to do so may cause damage to the vehicle, and possibly a fire or injury.

- Never use a fuse of a higher amperage rating than that indicated, or use any other object in place of a fuse.
- Always use a genuine Toyota fuse or equivalent. Never replace a fuse with a wire, even as a temporary fix.
- Do not modify the fuses or fuse boxes.



### NOTICE

#### ■ Before replacing fuses

Have the cause of electrical overload determined and repaired by your Toyota dealer as soon as possible.

#### ■ To prevent damage to the engine compartment fuse box cover

When opening the fuse box, completely release the claw locks before lifting up the cover. Otherwise, the claws may be damaged.

## Light bulbs

You may replace the following bulbs by yourself. The difficulty level of replacement varies depending on the bulb. As there is a danger that components may be damaged, we recommend that replacement is carried out by your Toyota dealer.

### Preparing for light bulb replacement

Check the wattage of the light bulb to be replaced. (→P.427)

### Bulb location

- ▶ Outside rear view mirrors

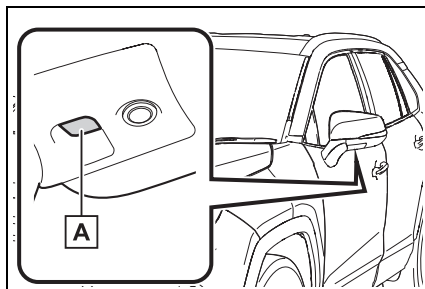

- A Outer foot lights (if equipped)

## ► Rear

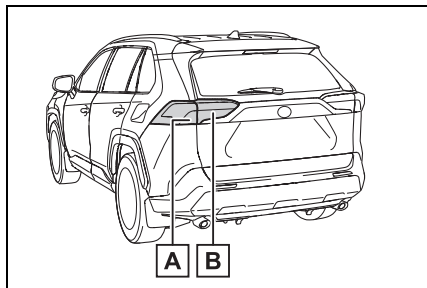

**A** Rear turn signal lights

**B** Back-up lights

■ **Lights that need to be replaced by your Toyota dealer**

- Headlights
- Front turn signal lights
- Daytime running lights
- Front position lights
- Fog lights
- Side turn signal lights
- Tail lights
- Stop lights
- High mounted stoplight
- License plate lights

■ **LED lights**

The lights other than the following lights each consist of a number of LEDs. If any of the LEDs burn out, take your vehicle to your Toyota dealer to have the light replaced.

- Rear turn signal lights
- Back-up lights
- Outer foot lights (if equipped)

■ **Condensation build-up on the inside of the lens**

Temporary condensation build-up on the inside of the light lens does not indicate a malfunction. Contact your Toyota dealer for more information in the following situations:

- Large drops of water have built up on the inside of the lens.
- Water has built up inside the light.

**Replacing light bulb**

■ **Rear turn signal lights**

- 1 Open the back door and remove the cover.

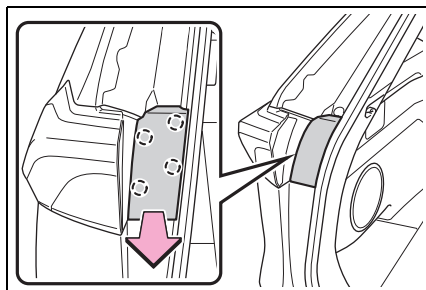

- 2 Remove the screws and remove the unit.

Remove the lamp assembly by pulling it directly backward from the rear of the vehicle.

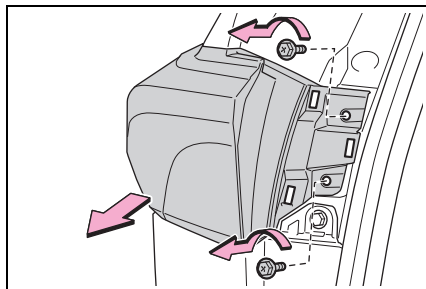

- 3** Turn the bulb base counter-clockwise.

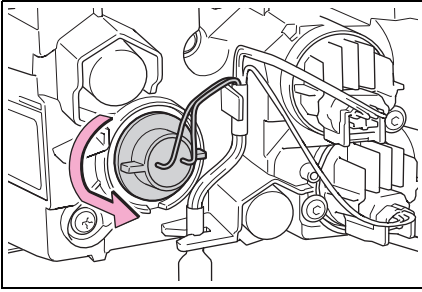

- 4** Remove the light bulb.

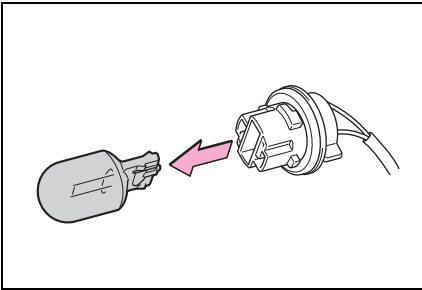

- 5** Install a new light bulb then install the bulb base to the light unit by inserting it and turning the bulb base clockwise.

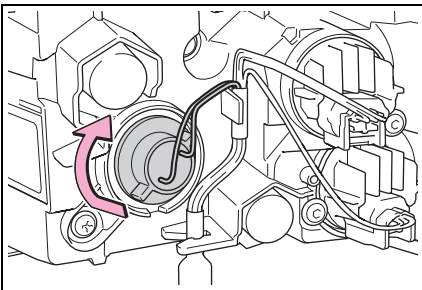

- 6** Align the grooves on the light unit with the claws, and insert the light unit straight so that the pin on the light unit fit into the hole.

Confirm that the light unit is completely secured.

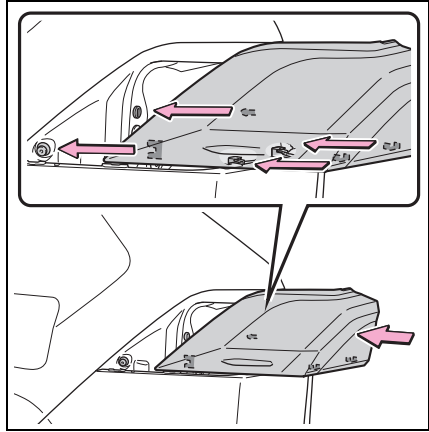

- 7** Reinstall the screws.

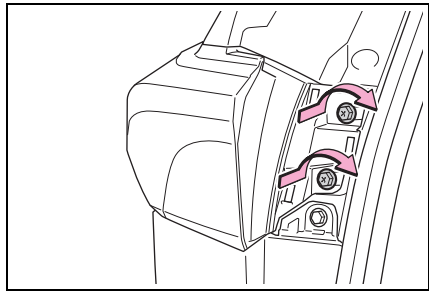

- 8** Reinstall the cover.

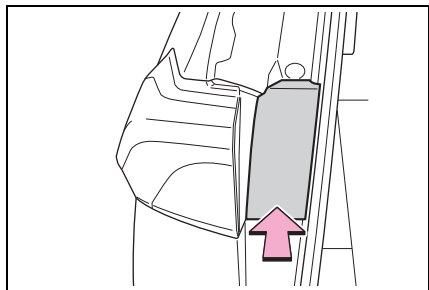

### ■ Back-up lights

- 1** Open the back door and remove the cover.

To prevent damage to the cover, pro-

Wipe the tip of the screwdriver with a rag.

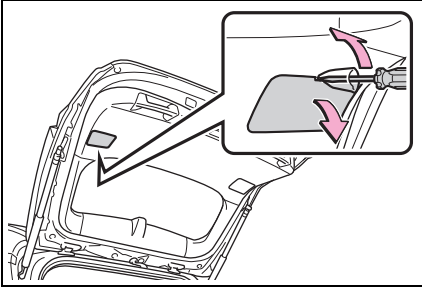

**2** Turn the bulb base counter-clockwise.

Remove the cord from the clip before turning the bulb base.

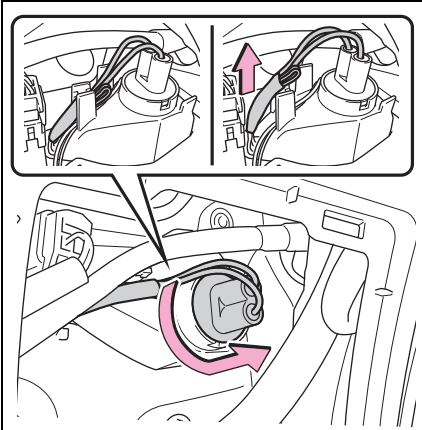

**3** Remove the light bulb.

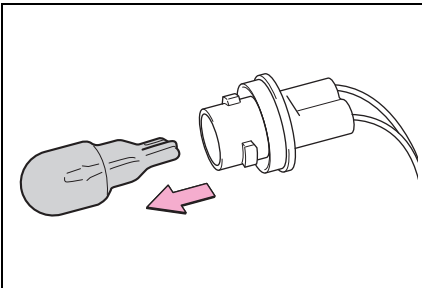

**4** Install a new light bulb.

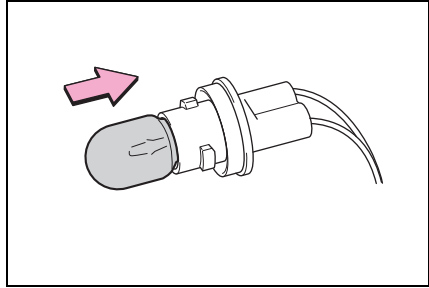

**5** Install the bulb base to the light unit by inserting it and turning the bulb base clockwise.

Secure the cord with the clip back again after installing the bulb base.

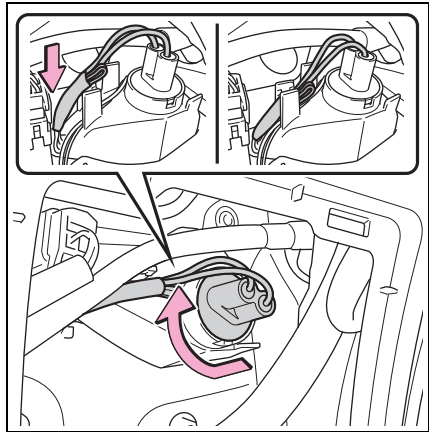

**6** Reinstall the cover.

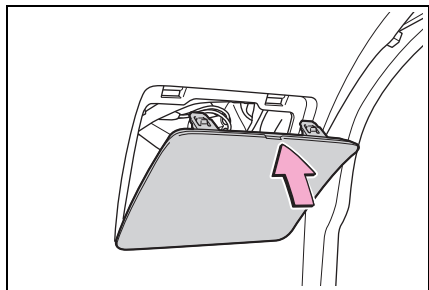

### ■ Outer foot lights (if equipped)

- 1 Press the upper part of the outside rear view mirror to tilt the mirror face upward, and disconnect the four tabs behind the mirror.

Pry the mirror out toward you, and disconnect two tabs at a time.

Work carefully, ensuring that you do not drop the mirror.

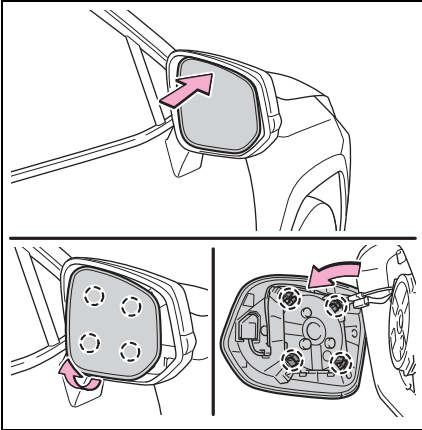

- 2 Disconnect the connectors behind the mirror, and remove the mirror.

Make sure to check the connectors, to avoid connecting upside down when reinstalling.

Work carefully, ensuring that you do not

drop the mirror.

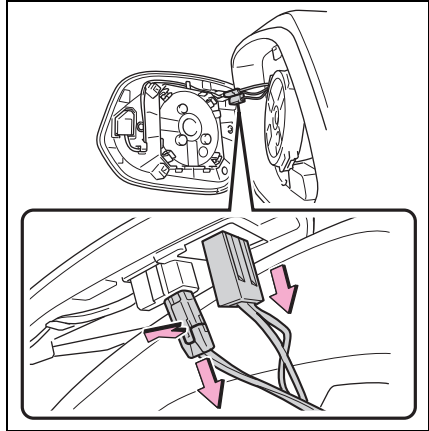

- 3 Disconnect the tabs behind the mirror cover, and remove the mirror cover.

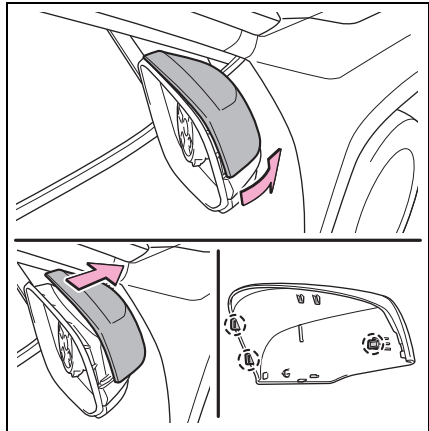

- 4** Fold the mirror before removing the light unit.

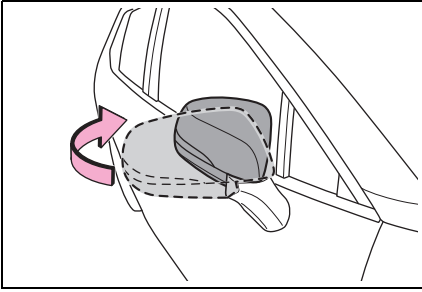

- 5** Remove the light unit.

Remove the two screws, and disengage the two tabs with a flat-head screwdriver.

Work carefully, ensuring that you do not damage the tabs.

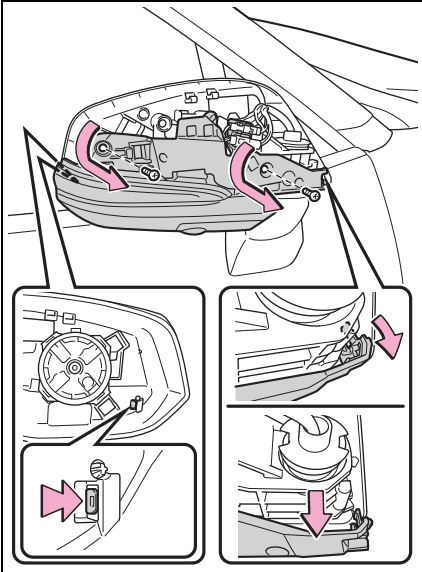

- 6** Turn the bulb base counter-clockwise.

Remove the cord from the clip before

turning the bulb base.

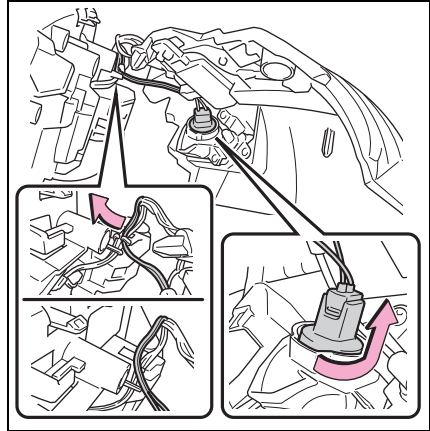

- 7** Remove the light bulb.

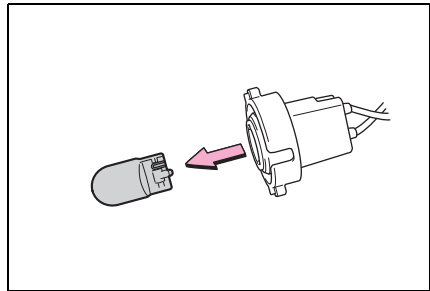

- 8** Install a new light bulb then install the bulb base to the light unit by inserting it and turning the bulb base clockwise.

Secure the cord with the clip back again

after installing the bulb base.

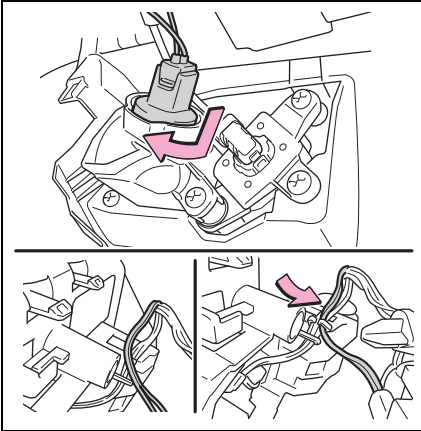

### 9 Install the light unit.

Make sure that the two tabs of the light unit are engaged securely, and install the two screws.

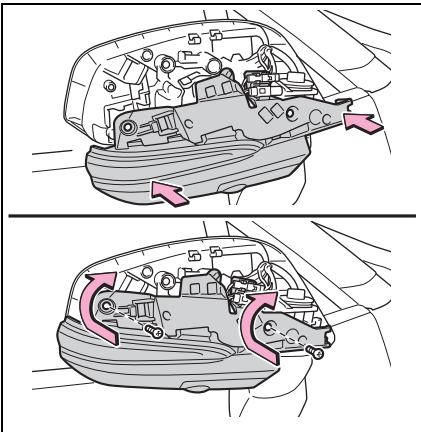

### 10 Extend the mirror.

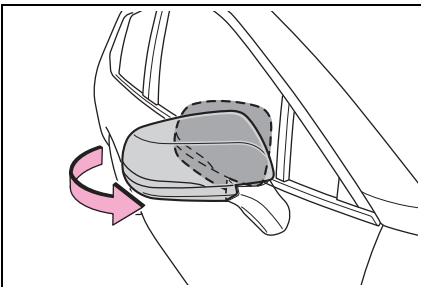

### 11 Install the mirror cover.

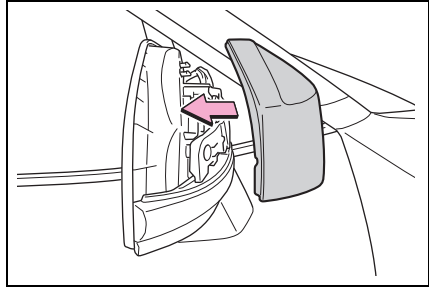

### 12 Reconnect the connectors of the mirror.

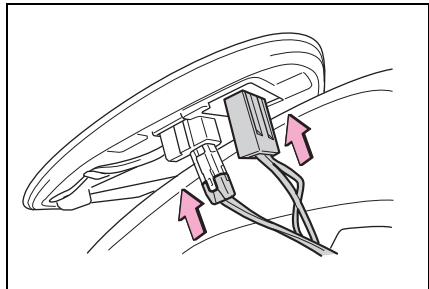

### 13 Align the tabs, and secure the mirror by pushing in each diagonally-opposite pair of tabs in order.

Make sure to insert the tabs in order as shown in the illustration, and push them in until a click is heard.

If you do not hear the click, do not force the tabs in. Instead, remove the mirror

and check that the tabs are aligned.

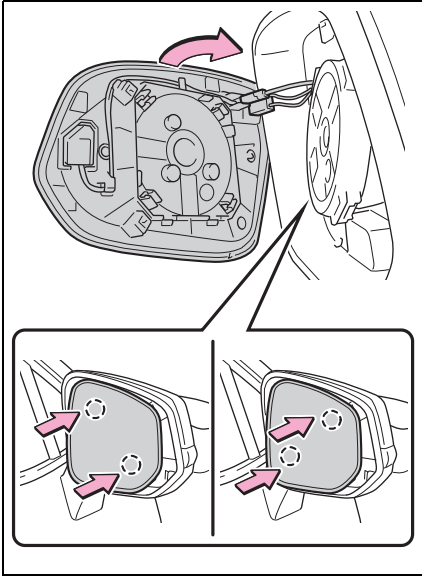

- Do not attempt to repair or disassemble light bulbs, connectors, electric circuits or component parts. Doing so may result in death or serious injury due to electric shock.

■ **To prevent damage or fire**

- Make sure bulb is fully seated and locked.
- Check the wattage of the bulb before installing to prevent heat damage.



**WARNING**

■ **Replacing light bulb**

- Turn off the light. Do not attempt to replace the bulb immediately after turning off the light. The bulb become very hot and may cause burns.
- Do not touch the glass portion of the light bulb with bare hands. When it is unavoidable to hold the glass portion, use and hold with a clean dry cloth to avoid getting moisture and oils on the bulb. Also, if the bulb is scratched or dropped, it may blow out or crack.
- Fully install light bulb and any parts used to secure it. Failure to do so may result in heat damage, fire, or water entering the light unit. This may damage the light or cause condensation to build up on the lens.



## When trouble arises

# 7

### 7-1. Essential information

Emergency flashers .....**376**

If your vehicle has to be  
stopped in an emergency  
.....**376**

If the vehicle is submerged or  
water on the road is rising  
.....**377**

### 7-2. Steps to take in an emergency

If your vehicle needs to be  
towed.....**379**

If you think something is wrong  
.....**383**

If a warning light turns on or a  
warning buzzer sounds...**385**

If a warning message is displayed.....**392**

If you have a flat tire .....**396**

If the hybrid system will not  
start .....**404**

If you lose your keys.....**405**

If the fuel filler door cannot be  
opened .....**406**

If the electronic key does not  
operate properly .....**406**

If the 12-volt battery is discharged .....**408**

If your vehicle overheats...**413**

If the vehicle becomes stuck  
.....**416**

## Emergency flashers

The emergency flashers are used to warn other drivers when the vehicle has to be stopped in the road due to a breakdown, etc.

### Operating instructions

Press the switch.

All the turn signal lights will flash.

To turn them off, press the switch once again.

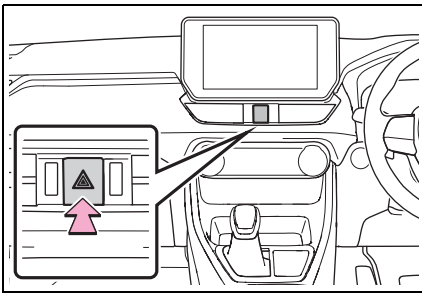

### Emergency flashers

- If the emergency flashers are used for a long time while the hybrid system is not operating (while the “READY” indicator is not illuminated), the 12-volt battery may discharge.
- If any of the SRS airbags deploy (inflate) or in the event of a strong rear impact, the emergency flashers will turn on automatically. The emergency flashers will turn off automatically after operating for approximately 20 minutes. To manually turn the emergency flashers off, press the switch twice. (The emergency flashers may not turn on automatically depending on the force of the impact and conditions of the collision.)

## If your vehicle has to be stopped in an emergency

Only in an emergency, such as if it becomes impossible to stop the vehicle in the normal way, stop the vehicle using the following procedure:

### Stopping the vehicle

- 1 Steadily step on the brake pedal with both feet and firmly depress it.

Do not pump the brake pedal repeatedly as this will increase the effort required to slow the vehicle.

- 2 Shift the shift lever to N.
  - ▶ If the shift lever is shifted to N
- 3 After slowing down, stop the vehicle in a safe place by the road.
- 4 Stop the hybrid system.
  - ▶ If the shift lever cannot be shifted to N
- 3 Keep depressing the brake pedal with both feet to reduce vehicle speed as much as possible.
- 4 To stop the hybrid system, press and hold the power switch for 2 consecutive seconds or more,

or press it briefly 3 times or more in succession.

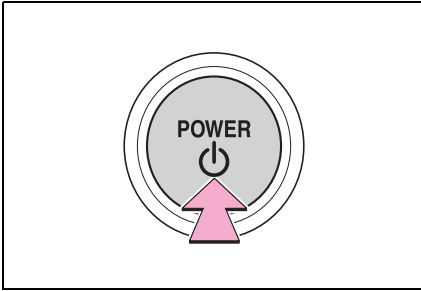

- 5 Stop the vehicle in a safe place by the road.



### WARNING

**■ If the hybrid system has to be turned off while driving**

Power assist for the steering wheel will be lost, making the steering wheel heavier to turn. Decelerate as much as possible before turning off the hybrid system.

## If the vehicle is submerged or water on the road is rising

**This vehicle is not designed to be able to drive on roads that are deeply flooded with water. Do not drive on roads where the roads may be submerged or the water may be rising. It is dangerous to remain in the vehicle, if it is anticipated that the vehicle will be flooded or set adrift. Remain calm and follow the following.**

- If the door can be opened, open the door and exit the vehicle.
- If the door cannot be opened, open the window using the power window switch and ensure an escape route.
- If the window can be opened, exit the vehicle through the window.
- If the door and window cannot be opened due to the rising water, remain calm, wait until the water level inside the vehicle rises to the point that the water pressure inside of the vehicle equals the water pressure outside of the vehicle and then open the door after waiting for the rising water to enter the vehicle, and exit the vehicle.

When the outside water level exceeds half the height of the door, the door cannot be opened from the inside due

to water pressure.

---

■ **Water level exceeds the floor**

When the water level exceeds the floor and time has passed, the electrical equipment will get damaged, the power windows will not operate, the engine and motor stop, and the vehicle may not be able to get moving.

■ **Using an emergency escape hammer\***

Laminated glass is used in the windshield on this vehicle. Laminated glass cannot be shattered with an emergency hammer\*. Tempered glass is used in the windows on this vehicle.

\*: Contact your Toyota dealer or after-market accessory manufacturer for further information about an emergency hammer.



**WARNING**

■ **Caution while driving**

Do not drive on roads where the roads may be submerged or the water may be rising. Otherwise the vehicle may be damaged and cannot move, as well as become flooded and set adrift, which may lead to death.

## If your vehicle needs to be towed

If towing is necessary, we recommend having your vehicle towed by your Toyota dealer or commercial towing service, using a wheel-lift type truck or flatbed truck.

Use a safety chain system for all towing, and abide by all state/provincial and local laws.

## Situations when it is necessary to contact dealers before towing

The following may indicate a problem with your transmission. Contact your Toyota dealer or commercial towing service before towing.

- The hybrid system warning message is shown on the multi-information display and the vehicle does not move.
- The vehicle makes an abnormal sound.

## Towing with a wheel-lift type truck

- ▶ From the front (2WD models)

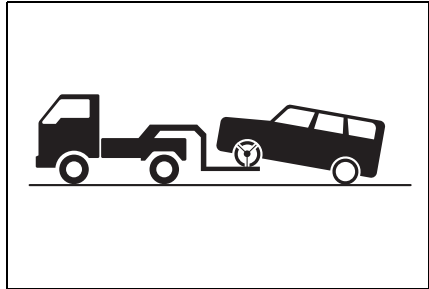

Release the parking brake.

Turn automatic mode off. (→P.188)

- ▶ From the front (AWD models)

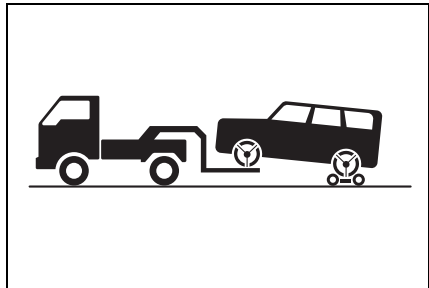

Use a towing dolly under the rear wheels.

- ▶ From the rear

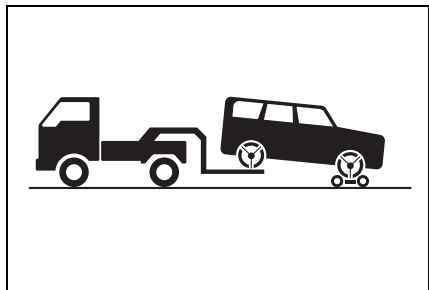

Use a towing dolly under the front wheels.

**WARNING**

Observe the following precautions. Failure to do so may result in death or serious injury.

■ **When towing the vehicle**

▶ 2WD models

Be sure to transport the vehicle with the front wheels raised or with all four wheels raised off the ground. If the vehicle is towed with the front wheels contacting the ground, the drivetrain and related parts may be damaged or electricity generated by the operation of the motor may cause a fire to occur depending on the nature of the damage or malfunction.

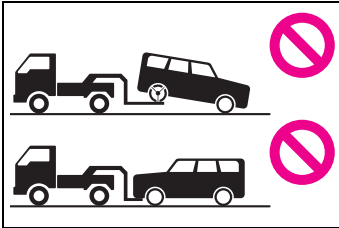

▶ AWD models

Be sure to transport the vehicle with all four wheels raised off the ground. If the vehicle is towed with the tires contacting the ground, the drivetrain or related parts may be damaged, the vehicle may fly off the truck, or electricity generated by the operation of the motor may cause a fire to occur depending on the nature of the damage or malfunction.

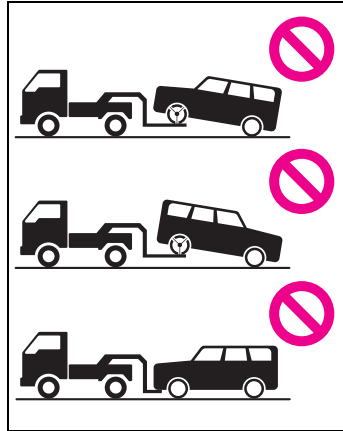
**NOTICE**

■ **To prevent damage to the vehicle when towing using a wheel-lift type truck**

When raising the vehicle, ensure adequate ground clearance for towing at the opposite end of the raised vehicle. Without adequate clearance, the vehicle could be damaged while being towed.

**NOTICE****■ Towing with a sling-type truck**

Do not tow with a sling-type truck to prevent body damage.

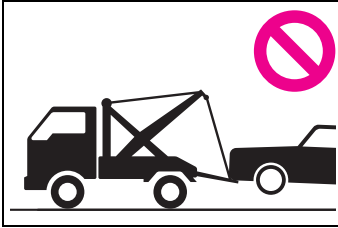
**Using a flatbed truck**

If your vehicle is transported by a flatbed truck, it should be tied down at the locations shown in the illustration.

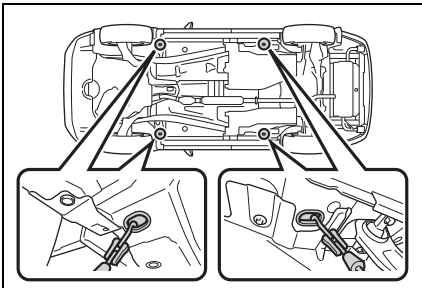

If you use chains or cables to tie down your vehicle, the angles shaded in black must be 45°.

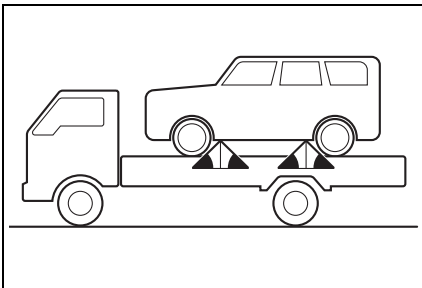

If you cannot tie down the vehicle using

the method above, use tire strapping belts.

**NOTICE****■ Using a flatbed truck**

Do not overly tighten the tie downs or the vehicle may be damaged.

**Emergency towing**

If a tow truck is not available in an emergency, your vehicle may be temporarily towed using cables or chains secured to the emergency towing eyelets. This should only be attempted on hard surfaced roads for short distances at under 30 km/h (18 mph).

A driver must be in the vehicle to steer and operate the brakes. The vehicle's wheels, drive train, axles, steering and brakes must be in good condition.

**Emergency towing procedure**

To have your vehicle towed by another vehicle, the towing eyelet must be installed to your vehicle. Install the towing eyelet using the following procedure.

- 1 Take out the wheel nut wrench and towing eyelet. (→P.397)
- 2 Using a flathead screwdriver, remove eyelet cover (A), and then remove eyelet cover (B).

To protect the bodywork, place a rag between the screwdriver and the vehi-

cle body as shown in the illustration.

► Type A

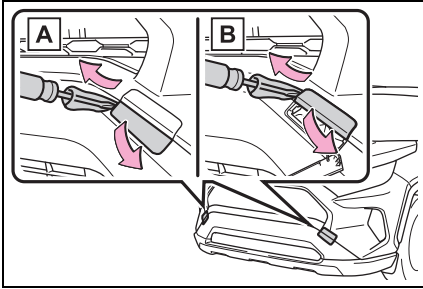

► Type B

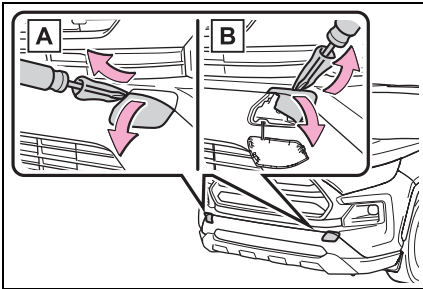

**3** Insert the towing eyelet into the hole and tighten partially by hand.

► Type A

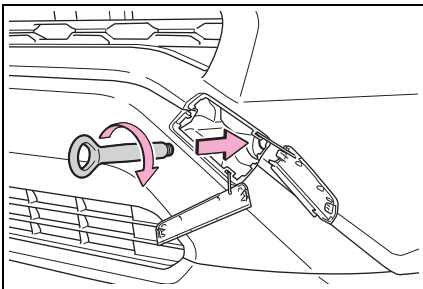

► Type B

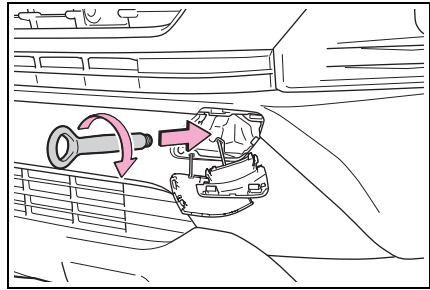

**4** Tighten down the towing eyelet securely using a wheel nut wrench or hard metal bar.

► Type A

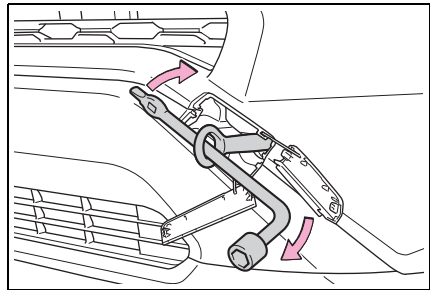

► Type B

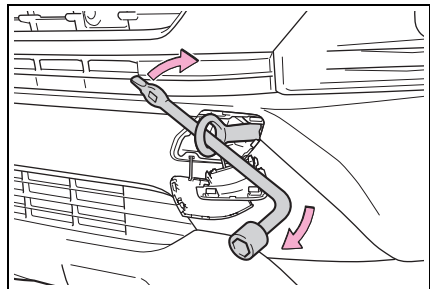

**5** Securely attach cables or chains to the towing eyelet.

Take care not to damage the vehicle body.

**6** Enter the vehicle being towed and start the hybrid system.



If the hybrid system does not start, turn the power switch to ON.

- 7** Shift the shift lever to N and release the parking brake.

Turn automatic mode off. (→P.188)

When the shift lever cannot be shifted:  
→P.184

#### ■ While towing

If the hybrid system is not running, the power assist for the brakes and steering will not function, making steering and braking more difficult.

#### ■ Wheel nut wrench

Wheel nut wrench is installed in the tool bag. (→P.397)



#### WARNING

Observe the following precautions. Failure to do so may result in death or serious injury.

#### ■ While towing

When towing using cables or chains, avoid sudden starts, etc. which place excessive stress on the towing eyelets, cables or chains. The towing eyelets, cables or chains may become damaged, broken debris may hit people, and cause serious damage.

#### ■ Installing towing eyelets to the vehicle

Make sure that towing eyelets are installed securely. If not securely installed, towing eyelets may come loose during towing.



#### NOTICE

#### ■ To prevent damage to the vehicle during emergency towing

Do not secure cables or chains to the suspension components.

### If you think something is wrong

**If you notice any of the following symptoms, your vehicle probably needs adjustment or repair. Contact your Toyota dealer as soon as possible.**

#### Visible symptoms

- Fluid leaks under the vehicle (Water dripping from the air conditioning after use is normal.)
- Flat-looking tires or uneven tire wear
- Engine coolant temperature gauge needle continually points higher than normal.

#### Audible symptoms

- Changes in exhaust sound
- Excessive tire squeal when cornering
- Strange noises related to the suspension system
- Pinging or other noises related to the hybrid system

#### Operational symptoms

- Engine missing, stumbling or running roughly
- Appreciable loss of power
- Vehicle pulls heavily to one side when braking

- Vehicle pulls heavily to one side when driving on a level road
- Loss of brake effectiveness, spongy feeling, pedal almost touches the floor

## If a warning light turns on or a warning buzzer sounds

Calmly perform the following actions if any of the warning lights comes on or flashes. If a light comes on or flashes, but then goes off, this does not necessarily indicate a malfunction in the system. However, if this continues to occur, have the vehicle inspected by your Toyota dealer.

### Actions to the warning lights or warning buzzers

#### ■ Brake system warning light (warning buzzer)

Warning light	Details/Actions
 (Red)	Indicates that: <ul style="list-style-type: none"> <li>● The brake fluid level is low; or</li> <li>● The brake system is malfunctioning</li> </ul> → <b>Immediately stop the vehicle in a safe place and contact your Toyota dealer. Continuing to drive the vehicle may be dangerous.</b>

#### ■ Brake system warning light

Warning light	Details/Actions
 (Yellow)	Indicates a malfunction in: <ul style="list-style-type: none"> <li>● The parking brake system;</li> <li>● The regenerative braking system; or</li> <li>● The electronically controlled brake system</li> </ul> → <b>Have the vehicle inspected by your Toyota dealer immediately.</b>

#### ■ Charging system warning light\*

Warning light	Details/Actions
	Indicates a malfunction in the vehicle's charging system → <b>Immediately stop the vehicle in a safe place and contact your Toyota dealer.</b>

\*: Vehicles with 12.3-inch multi-information display: This light illuminates on the multi-information display with a message.

### ■ High coolant temperature warning light\* (warning buzzer)

Warning light	Details/Actions
	Indicates that the engine is overheating → <b>Immediately stop the vehicle in a safe place.</b> <b>Handling method (→P.413)</b>

\*: This light illuminates on the multi-information display with a message.

### ■ Hybrid system overheat warning light\* (warning buzzer)

Warning light	Details/Actions
	Indicates that the hybrid system has overheated → <b>Stop the vehicle in a safe place.</b> <b>Handling method (→P.413)</b>

\*: This light illuminates on the multi-information display with a message.

### ■ Low engine oil pressure warning light\* (warning buzzer)

Warning light	Details/Actions
	Indicates that the engine oil pressure is too low → <b>Immediately stop the vehicle in a safe place and contact your Toyota dealer.</b>

\*: This light illuminates on the multi-information display with a message.

### ■ Malfunction indicator lamp

Warning light	Details/Actions
	Indicates a malfunction in: <ul style="list-style-type: none"> <li>● The hybrid system;</li> <li>● The electronic engine control system;</li> <li>● The electronic throttle control system; or</li> <li>● The emission control system (if equipped)</li> </ul> → <b>Have the vehicle inspected by your Toyota dealer immediately.</b>



### ■ SRS warning light

Warning light	Details/Actions
	<p>Indicates a malfunction in:</p> <ul style="list-style-type: none"> <li>● The SRS airbag system; or</li> <li>● The seat belt pretensioner system</li> </ul> <p>→ <b>Have the vehicle inspected by your Toyota dealer immediately.</b></p>

### ■ ABS warning light

Warning light	Details/Actions
	<p>Indicates a malfunction in:</p> <ul style="list-style-type: none"> <li>● The ABS; or</li> <li>● The brake assist system</li> </ul> <p>→ <b>Have the vehicle inspected by your Toyota dealer immediately.</b></p>

### ■ Electric power steering system warning light (warning buzzer)

Warning light	Details/Actions
 <p>(Red)</p>  <p>(Yellow)</p>	<p>Indicates a malfunction in the EPS (Electric Power Steering) system</p> <p>→ <b>Have the vehicle inspected by your Toyota dealer immediately.</b></p>

### ■ PCS warning light (warning buzzer)

Warning light	Details/Actions
 <p>(Flashes or illuminates) (If equipped)</p>	<p>When a buzzer sounds simultaneously: Indicates a malfunction has occurred in the PCS (Pre-Collision System). → <b>Have the vehicle inspected by your Toyota dealer immediately.</b></p> <p>When a buzzer does not sound: The PCS (Pre-Collision System) has become temporarily unavailable, corrective action may be necessary. → <b>Follow the instructions displayed on the multi-information display (→P.208, 394)</b></p> <p>If the PCS (Pre-Collision System) or VSC (Vehicle Stability Control) system is disabled, the PCS warning light will illuminate. → <b>P.220</b></p>

### ■ LTA indicator (warning buzzer)

Warning light	Details/Actions
 <p>(Orange) (If equipped)</p>	<p>Indicates a malfunction in the LTA (Lane Tracing Assist) → <b>Follow the instructions displayed on the multi-information display. (→P.230)</b></p>

### ■ Toyota parking assist-sensor OFF indicator (warning buzzer)

Warning light	Details/Actions
 <p>(Flashes) (If equipped)</p>	<p>When a buzzer sounds: Indicates a malfunction in the Toyota parking assist-sensor function → <b>Have the vehicle inspected by your Toyota dealer immediately.</b></p> <p>When a buzzer does not sound: Indicates that the system is temporarily unavailable, possibly due to a sensor being dirty or covered with ice, etc. → <b>Follow the instructions displayed on the multi-information display. (→P.255, 392)</b></p>

### ■ PKSB OFF indicator

Warning light	Details/Actions
 <p>(Flashes) (If equipped)</p>	<p>When a buzzer sounds: Indicates a malfunction in the PKSB (Parking Support Brake) system</p> <p>→ <b>Have the vehicle inspected by any authorized Toyota retailer or Toyota authorized repairer, or any reliable repairer immediately.</b></p> <p>When a buzzer does not sound: Indicates that the system is temporarily unavailable, possibly due to a sensor being dirty or covered with ice, etc.</p> <p>→ <b>Follow the instructions displayed on the multi-information display. (→P.208, 392)</b></p>

### ■ RCTA OFF indicator (warning buzzer)

Warning light	Details/Actions
 <p>(Flashes) (If equipped)</p>	<p>When a buzzer sounds: Indicates a malfunction in the RCTA (Rear Cross Traffic Alert) function</p> <p>→ <b>Have the vehicle inspected by your Toyota dealer immediately.</b></p> <p>When a buzzer does not sound: Indicates that the rear bumper around the radar sensor is covered with dirt, etc. (→P.250)</p> <p>→ <b>Follow the instructions displayed on the multi-information display. (→P.263, 392)</b></p>

### ■ Slip indicator light

Warning light	Details/Actions
	<p>Indicates a malfunction in:</p> <ul style="list-style-type: none"> <li>● The VSC/Trailer Sway Control system;</li> <li>● The TRC system;</li> <li>● The Trail Mode function (if equipped); or</li> <li>● The hill-start assist control system</li> </ul> <p>→ <b>Have the vehicle inspected by your Toyota dealer immediately.</b></p>

### ■ Inappropriate pedal operation warning light\* (warning buzzer)

Warning light	Details/Actions
	<p>When a buzzer sounds:</p> <ul style="list-style-type: none"> <li>● Brake Override System is malfunctioning</li> <li>● Drive-Start Control is malfunctioning</li> <li>● Drive-Start Control is operating</li> </ul> <p>→ <b>Follow the instructions displayed on the multi-information display.</b></p> <p>When a buzzer does not sound:</p> <p>Brake Override System is operating</p> <p>→ <b>Release the accelerator pedal and depress the brake pedal.</b></p>

\*: This light illuminates on the multi-information display with a message.

### ■ Brake hold operated indicator (warning buzzer)

Warning light	Details/Actions
 <p>(Flashes)</p>	<p>Indicates a malfunction in the brake hold system</p> <p>→ <b>Have the vehicle inspected by your Toyota dealer immediately.</b></p>

### ■ Parking brake indicator

Warning light	Details/Actions
 <p>(Flashes)</p>	<p>It is possible that the parking brake is not fully engaged or released</p> <p>→ <b>Operate the parking brake switch once again.</b></p> <p>This light comes on when the parking brake is not released. If the light turns off after the parking brake is fully released, the system is operating normally.</p>

### ■ Low fuel level warning light

Warning light	Details/Actions
	<p>Indicates that remaining fuel is approximately 8.3 L (2.2 gal., 1.8 Imp. gal.) or less</p> <p>→ <b>Refuel the vehicle.</b></p>



## ■ Driver's and front passenger's seat belt reminder light\*<sup>1</sup> (warning buzzer)\*<sup>2</sup>

Warning light	Details/Actions
	<p>Warns the driver and/or front passenger to fasten their seat belts</p> <p>→ <b>Fasten the seat belt.</b></p> <p><b>If the front passenger's seat is occupied, the front passenger's seat belt also needs to be fastened to make the warning light (warning buzzer) turn off.</b></p>

\*<sup>1</sup>: This light illuminates on the multi-information display.

\*<sup>2</sup>: Driver's and front passenger's seat belt warning buzzer:

The driver's and front passenger's seat belt warning buzzer sounds to alert the driver and front passenger that his or her seat belt is not fastened. If the seat belt is unfastened, the buzzer sounds intermittently for a certain period of time after the vehicle reaches a certain speed.

## ■ Rear passengers' seat belt reminder lights\*<sup>1</sup> (warning buzzer)\*<sup>2</sup>

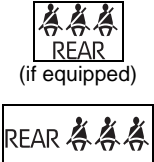
Warning light	Details/Actions
	<p>Warns the rear passengers to fasten their seat belts</p> <p>→ <b>Fasten the seat belt.</b></p>

\*<sup>1</sup>: These lights illuminate on the multi-information display.

\*<sup>2</sup>: Rear passengers' seat belt warning buzzer:

The rear passengers' seat belt warning buzzer sounds to alert the rear passenger that his or her seat belt is not fastened. If the seat belt is unfastened, the buzzer sounds intermittently for a certain period of time after the vehicle reaches a certain speed.

### ■ Warning buzzer

In some cases, the buzzer may not be heard because of noisy place or an audio sound.

### ■ Front passenger detection sensor, seat belt reminder and warning buzzer

● If luggage is placed on the front pas-

senger seat, the front passenger detection sensor may cause the warning light to flash and the warning buzzer to sound even if a passenger is not sitting in the seat.

● If a cushion is placed on the seat, the sensor may not detect a passenger, and the warning light may not operate properly.

### ■ If the malfunction indicator lamp comes on while driving

The malfunction indicator lamp will come on if the fuel tank becomes completely empty. If the fuel tank is empty, refuel the vehicle immediately. The malfunction indicator lamp will go off after several trips.

If the malfunction indicator lamp does not go off, contact your Toyota dealer as soon as possible.

### ■ Electric power steering system warning light (warning buzzer)

When the 12-volt battery charge becomes insufficient or the voltage temporarily drops, the electric power steering system warning light may come on and the warning buzzer may sound.



#### WARNING

### ■ If a warning light comes on or a warning buzzer sounds when a warning message is shown on the multi-information display\*

Check and follow the message shown on the multi-information display.

Failure to do so may result in death or serious injury.

\*: Warning lights illuminate in red or yellow and the warning buzzer beeps once or sounds continuously.

### ■ When the electric power steering system warning light comes on

When the light comes on yellow, the assist to the power steering is restricted. When the light comes on red, the assist to the power steering is lost and handling operations of the steering wheel become extremely heavy.

If the steering wheel becomes heavier than usual when operating, hold firmly and operate using more force than usual.

### If a warning message is displayed

The multi-information display shows warnings of system malfunctions, incorrectly performed operations, and messages that indicate a need for maintenance. When a message is shown, perform the correction procedure appropriate to the message.

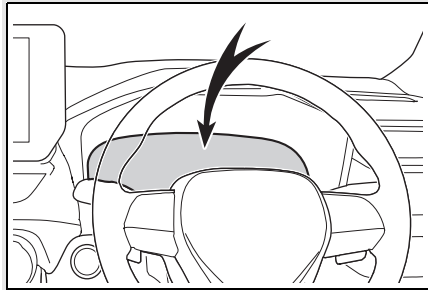

If a warning message is displayed again after the appropriate actions have been performed, contact your Toyota dealer.

### ■ Warning messages

The warning messages explained below may differ from the actual messages according to operation conditions and vehicle specifications.

#### ■ If a message about an operation is shown

- If a message about an operation of the accelerator pedal or brake pedal is shown
- A warning message about an operation of the brake pedal may be shown while the driving assist systems such as PCS (Pre-Collision system) (if equipped) or the dynamic radar cruise

control with full-speed range (if equipped) is operating. If a warning message is shown, be sure to decelerate the vehicle or follow the instruction shown on the multi-information display.

- A warning message is shown when Brake Override System operates. (→P.163)
- A warning message is shown when Drive-Start Control or Parking Support Brake (if equipped) (→P.167, 268) operates. Follow the instructions on the multi-information display.
- If a message about an operation of the power switch is shown

An instruction for operation of the power switch is shown when the incorrect procedure for starting the hybrid system is performed or the power switch is operated incorrectly. Follow the instructions shown on the multi-information display to operate the power switch again.

- If a message about a shift lever operation is shown

To prevent the shift lever from being operated incorrectly or the vehicle from moving unexpectedly, a message that requires shifting the shift lever may be shown on the multi-information display. In that case, follow the instruction of the message and shift the shift lever.

- If a message or image about an open/close state of a part or replenishment of a consumable is shown  
Confirm the part indicated by the multi-information display or a warning light, and then perform the coping method such as closing the open door or replenishing a consumable.

**■ If a message that indicates the need for visiting your Toyota dealer is displayed**

The system or part shown on the multi-information display is malfunctioning. Have the vehicle inspected by your

Toyota dealer immediately.

**■ If a message that indicates the need for referring to Owner's Manual is displayed**

- If the following messages are shown, there may be a malfunction. Immediately have the vehicle inspected by your Toyota dealer.
  - "Hybrid System Malfunction"
  - "Check Engine"
  - "Hybrid Battery System Malfunction"
  - "Accelerator System Malfunction"
  - "Smart Entry & Start System Malfunction"
  - "Engine Coolant Temp High" (→P.413)
- If the following messages are shown, there may be a malfunction. Immediately stop the vehicle in a safe place and contact your Toyota dealer. Continuing to drive the vehicle may be dangerous.
  - "Oil Pressure Low"
  - "Braking Power Low"
- If "Maintenance Required for Traction Battery Cooling Parts See Owner's Manual" is shown, the filter may be clogged, the air intake vent may be blocked, or there may be a gap in the duct. Therefore, perform the following correction procedure.
  - If the air intake vent or filter of the hybrid battery (traction battery) are dirty, perform the procedures on P.355 to clean them.
  - If the warning message is shown when the air intake vent and filter of the hybrid battery (traction battery) are not dirty, have the vehicle inspected at your Toyota dealer.

**■ If "Hybrid System Overheated Output Power Reduced" is shown**

The message may be shown when driving under severe operating conditions. (For example, when driving up a long steep hill or driving up a steep hill in reverse.)

Coping method: →P.413

■ If **“Traction Battery Needs to be Protected Refrain from the Use of N Position”** is shown

This message may be displayed when the shift lever is in N.

As the hybrid battery (traction battery) cannot be charged when the shift lever is in N, shift the shift lever to P when the vehicle is stopped.

■ If **“Traction Battery Needs to be Protected Shift into P to Restart”** is shown

This message is displayed when the hybrid battery (traction battery) charge has become extremely low because the shift lever has been left in N for a certain amount of time.

When operating the vehicle, shift to P and restart the hybrid system.

■ If **“Shift to P when Parked”** is shown

Message is displayed when the driver's door is opened without turning the power switch to OFF with the shift lever in any position other than P.

Shift the shift lever to P.

■ If **“Shift is in N Release Accelerator Before Shifting”** is shown

Message is displayed when the accelerator pedal has been depressed and the shift lever is in N. Release the accelerator pedal and shift the shift lever to D or R.

■ If **“Press Brake when Vehicle is Stopped Hybrid System may Overheat”** is shown

Message is displayed when the accelerator pedal is depressed to maintain the vehicle position when stopped on an upward slope, etc.

If this continues, the hybrid system may overheat.

Release the accelerator pedal and depress the brake pedal.

■ If **“Auto Power OFF to Conserve Battery”** is shown

Power was turned off due to the auto-

matic power off function.

Next time when starting the hybrid system, operate the hybrid system for approximately 5 minutes to recharge the 12-volt battery.

■ If **“Engine Oil Level Low Add or Replace”** is displayed

The engine oil level may be low. Check the level of the engine oil, and add engine oil if necessary. (→P.344) This message may be displayed if the vehicle is stopped on a slope. Move the vehicle to a level surface and check if the message disappears.

■ If a message that indicates the malfunction of front camera is displayed

The following systems may be suspended until the problem shown in the message is resolved. (→P.208, 385)

- PCS (Pre-Collision System)\*
- LTA (Lane Tracing Assist)\*
- AHB (Automatic High Beam)\*
- RSA (Road Sign Assist)\*
- Dynamic radar cruise control with full-speed range\*

\*: If equipped

■ If a message that indicates the malfunction of radar sensor is displayed

The following systems may be suspended until the problem shown in the message is resolved. (→P.208, 385)

- PCS (Pre-Collision System)\*
- LTA (Lane Tracing Assist)\*
- Dynamic radar cruise control with full-speed range\*

\*: If equipped

■ If **“Radar Cruise Control Unavailable See Owner's Manual”** is shown

The dynamic radar cruise control with full-speed range (if equipped) system is

suspended temporarily or until the problem shown in the message is resolved. (causes and coping methods: →P.208)

■ **If “Radar Cruise Control Unavailable” is shown**

The dynamic radar cruise control with full-speed range (if equipped) system cannot be used temporarily. Use the system when it becomes available again.

■ **Warning buzzer**

→P.391



**WARNING**

- **If a warning light comes on or a warning buzzer sounds when a warning message is shown on the multi-information display**

→P.392



**NOTICE**

- **“High Power Consumption Partial Limit On AC/Heater Operation” is frequently shown**

There is a possible malfunction relating to the charging system or the 12-volt battery may be deteriorating. Have the vehicle inspected by your Toyota dealer.

## If you have a flat tire

Your vehicle is equipped with a spare tire. The flat tire can be replaced with the spare tire.

For details about tires: →P.349



### WARNING

#### ■ If you have a flat tire

Do not continue driving with a flat tire.

Driving even a short distance with a flat tire can damage the tire and the wheel beyond repair, which could result in an accident.

## Before jacking up the vehicle

- Stop the vehicle in a safe place on a hard, flat surface.
- Set the parking brake.
- Shift the shift lever to P.
- Stop the hybrid system.
- Turn on the emergency flashers. (→P.376)
- For vehicles with power back door: Turn off the power back door system. (→P.128)

## Location of the spare tire, jack and tools

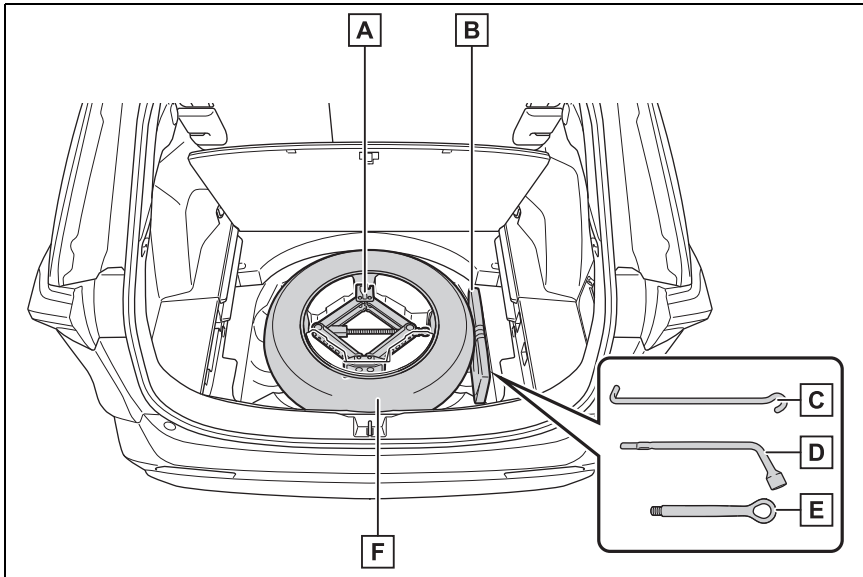

**A** Jack

**B** Tool bag

**C** Jack handle

**D** Wheel nut wrench

**E** Towing eyelet

**F** Spare tire



### WARNING

#### ■ Using the tire jack

Observe the following precautions. Improper use of the tire jack may cause the vehicle to suddenly fall off the jack, leading to death or serious injury.

- Do not use the tire jack for any purpose other than replacing tires or installing and removing tire chains.
- The equipped jack can only be used with your vehicle. Do not use it with other vehicles.

- And do not use jacks from other vehicles with your vehicle.
- Put the jack properly in its jack point.

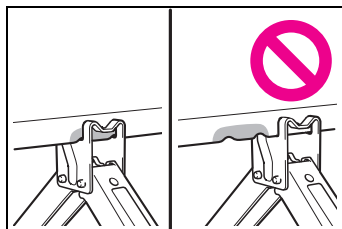

**WARNING**

- Do not put any part of your body under the vehicle while it is supported by the jack.
- Do not start the hybrid system or drive the vehicle while the vehicle is supported by the jack.
- Do not raise the vehicle while someone is inside.
- When raising the vehicle, do not put an object on or under the jack.
- Do not raise the vehicle to a height greater than that required to replace the tire.
- Use a jack stand if it is necessary to get under the vehicle.
- Stop the vehicle on firm, flat and level ground, firmly set the parking brake and shift the shift lever to P. Block the wheel diagonally opposite to the one being changed if necessary.
- When lowering the vehicle, make sure that there is no-one near the vehicle. If there are people nearby, warn them vocally before lowering.

**Taking out the jack**

- 1 Vehicles without full-size spare tire: Open the deck board (→P.312).  
Vehicles with full-size spare tire: Take out the deck board.
- 2 Take out the jack.  
Do not touch the threaded portion of the

jack as it is greased.

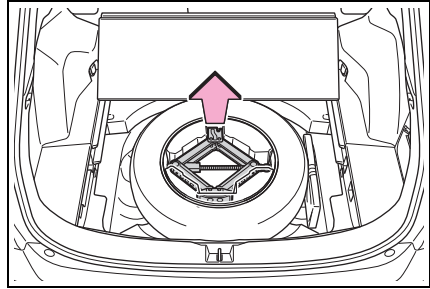
**Taking out the tool bag**

Take out the tool bag.

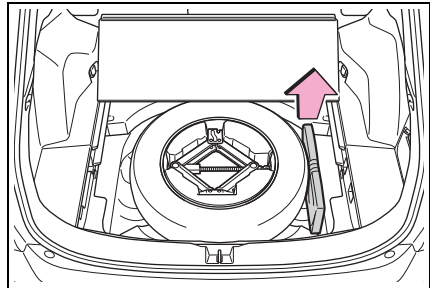
**Taking out the spare tire**

- 1 Take out the jack holder.

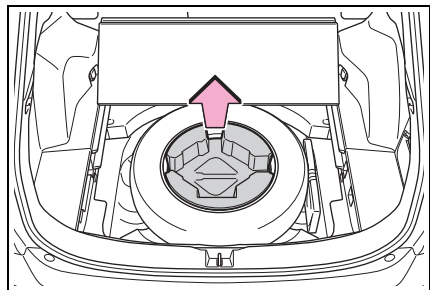

Loosen the center fastener that secures the spare tire.



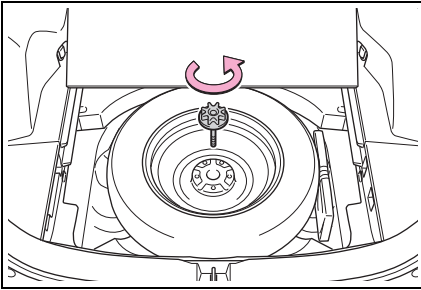

**⚠ WARNING**

**■ When storing the spare tire**

Be careful not to catch fingers or other body parts between the spare tire and the body of the vehicle.

## Replacing a flat tire

### 1 Check the tires.

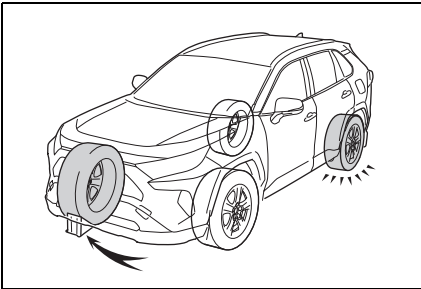

Flat tire	Wheel chock positions
Front left-hand side	Behind the rear right-hand side tire
Front right-hand side	Behind the rear left-hand side tire
Rear left-hand side	In front of the front right-hand side tire
Rear right-hand side	In front of the front left-hand side tire

### 2 Slightly loosen the wheel nuts (one turn).

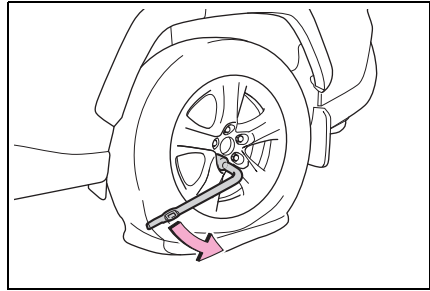

### 3 Turn the tire jack portion **A** by hand until the notch of the jack is in contact with the jack point.

After removing the jack from the jack holder, turn the jack portion **A** in the opposite direction to lower the jack, and then adjust the jack set position.

The jack point guides are located under the rocker panel. They indicate the jack positions.

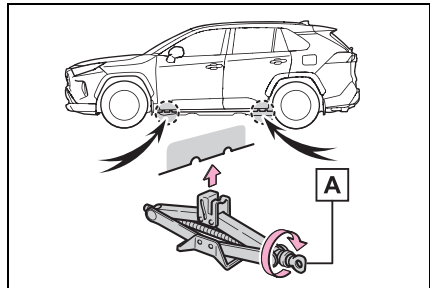

- 4 Assemble the jack handle and the wheel nut wrench as shown in the illustration.

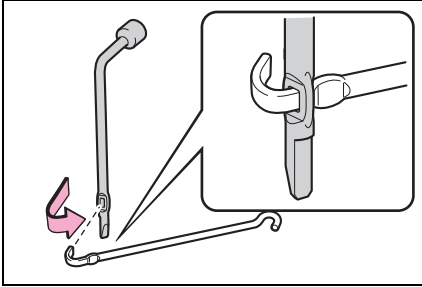

- 5 Raise the vehicle until the tire is slightly raised off the ground.

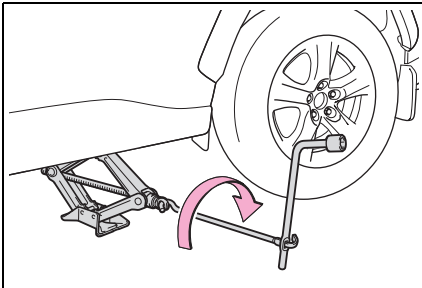

- 6 Remove all the wheel nuts and the tire.

When resting the tire on the ground, place the tire so that the wheel design faces up to avoid scratching the wheel surface.

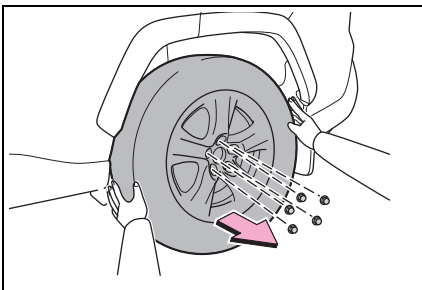

### ⚠ WARNING

#### ■ Replacing a flat tire

- Do not touch the disc wheels or the area around the brakes immediately after the vehicle has been driven.

After the vehicle has been driven the disc wheels and the area around the brakes will be extremely hot. Touching these areas with hands, feet or other body parts while changing a tire, etc. may result in burns.

- Failure to follow these precautions could cause the wheel nuts to loosen and the tire to fall off, resulting in death or serious injury.

- After replacing a tire, check the tightening torque as soon as possible.

Wheel nut torque: 103 N•m (10.5 kgf•m, 76 ft•lbf)

- When installing a tire, only use wheel nuts that have been specifically designed for that wheel.
- If there are any cracks or deformations in the bolt screws, nut threads or bolt holes of the wheel, have the vehicle inspected by your Toyota dealer.
- When installing the wheel nuts, be sure to install them with the tapered ends facing inward.

- For vehicles with power back door: In cases such as when replacing tires, make sure to turn off the power back door system (→P.128). Failure to do so may cause the back door to operate unintentionally if the power back door switch is accidentally touched, resulting in hands and fingers being caught and injured.

## Installing the spare tire

- 1 Remove any dirt or foreign matter from the wheel contact surface.

If foreign matter is on the wheel contact surface, the wheel nuts may loosen while the vehicle is in motion, causing the tire to come off.

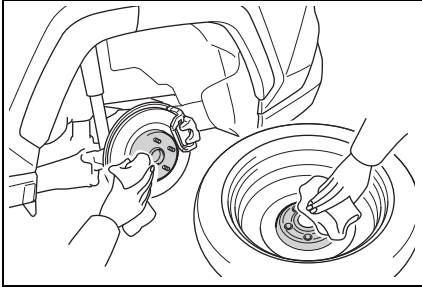

- 2 Install the spare tire and loosely tighten each wheel nut by hand by approximately the same amount.

When replacing an aluminum wheel with a steel wheel, tighten the wheel nuts until the tapered portion (A) comes into loose contact with the disc wheel seat (B).

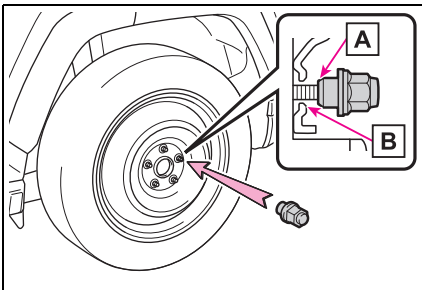

When replacing an aluminum wheel with an aluminum wheel, turn the wheel nuts until the washers (A) come into

contact with the disc wheel (B).

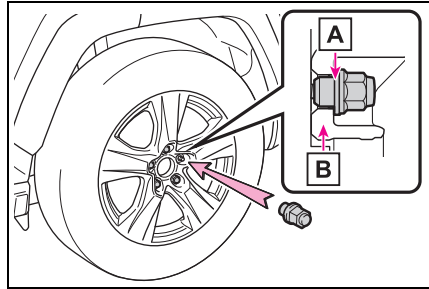

- 3 Lower the vehicle.

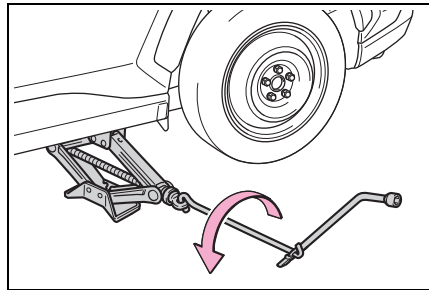

- 4 Securely tighten the wheel nuts two or three times in the order shown in the illustration using a wheel nut wrench.

Tightening torque:  
103 N•m (10.5 kgf•m, 76 ft•lb)

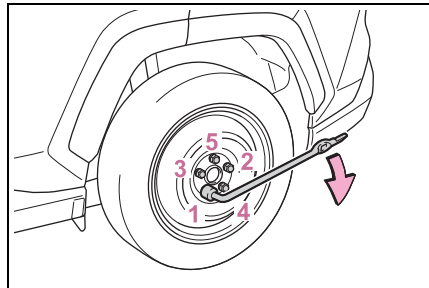

- 5 Stow the flat tire, tire jack and all tools.

■ **The compact spare tire (if equipped)**

- The compact spare tire is identified by the label “TEMPORARY USE ONLY” on the tire sidewall. Use the compact spare tire temporarily, and only in an emergency.
- Make sure to check the tire inflation pressure of the compact spare tire. (→P.426)

■ **When the compact spare tire (if equipped) is attached**

The vehicle height may become lower when driving with the compact spare tire compared to when driving with standard tires.

■ **If you have a flat front tire on a road covered with snow or ice (vehicles with compact spare tire)**

Install the compact spare tire on one of the rear wheels of the vehicle. Perform the following steps and fit tire chains to the front tires:

- 1 Replace a rear tire with the compact spare tire.
- 2 Replace the flat front tire with the tire removed from the rear of the vehicle.
- 3 Fit tire chains to the front tires.

■ **When stowing the jack**

Before storing the jack, adjust the height of the jack to match the shape of the jack holder.

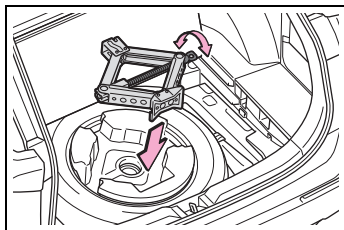

**! WARNING**

■ **When using the compact spare tire (if equipped)**

- Remember that the compact spare tire provided is specifically designed for use with your vehicle. Do not use your compact spare tire on another vehicle.
- Do not use more than one compact spare tire simultaneously.
- Replace the compact spare tire with a standard tire as soon as possible.
- Avoid sudden acceleration, abrupt steering, sudden braking and shifting operations that cause sudden engine braking.

■ **When the compact spare tire (if equipped) is attached**

The vehicle speed may not be correctly detected, and the following systems may not operate correctly:

- ABS & Brake assist
- VSC/Trailer Sway Control
- TRC
- Cruise control (if equipped)
- Dynamic radar cruise control with full-speed range (if equipped)
- PCS (Pre-Collision System) (if equipped)
- EPS
- LTA (Lane Tracing Assist) (if equipped)
- Tire pressure warning system (if equipped)
- AHB (Automatic High Beam) (if equipped)
- BSM (if equipped)
- RCTA (if equipped)

**WARNING**

- PKSB (if equipped)
- Toyota parking assist-sensor
- Rear view monitor system (if equipped)
- Panoramic view monitor (if equipped)
- Toyota parking assist monitor (if equipped)
- Navigation system (if equipped)

Also, not only can the following system not be utilized fully, but it may actually negatively affect the drivetrain components:

- E-Four (Electronic On-Demand AWD system) (if equipped)

■ **Speed limit when using the compact spare tire (if equipped)**

Do not drive at speeds in excess of 80 km/h (50 mph) when a compact spare tire is installed on the vehicle.

The compact spare tire is not designed for driving at high speeds. Failure to observe this precaution may lead to an accident causing death or serious injury.

■ **After using the tools and jack**

Before driving, make sure all the tools and jack are securely in place in their storage location to reduce the possibility of personal injury during a collision or sudden braking.

**NOTICE**

■ **Be careful when driving over bumps with the compact spare tire installed on the vehicle (if equipped)**

The vehicle height may become lower when driving with the compact spare tire compared to when driving with standard tires. Be careful when driving over uneven road surfaces.

■ **Driving with tire chains and the compact spare tire (if equipped)**

- Compact spare tires fitted to this vehicle must have a maximum load rating of not less than 900 kg or a load index of 104 and a speed category symbol of not less than M (130 km/h).
- Do not fit tire chains to the compact spare tire. Tire chains may damage the vehicle body and adversely affect driving performance.

### **If the hybrid system will not start**

Reasons for the hybrid system not starting vary depending on the situation. Check the following and perform the appropriate procedure:

#### **The hybrid system will not start even though the correct starting procedure is being followed (→P.177)**

One of the following may be the cause of the problem:

- The electronic key may not be functioning properly. (→P.406)
- There may not be sufficient fuel in the vehicle's tank.  
Refuel the vehicle. (→P.203)
- There may be a malfunction in the immobilizer system. (→P.68)
- The hybrid system may be malfunctioning due to an electrical problem such as electronic key battery depletion or a blown fuse. However, depending on the type of malfunction, an interim measure is available to start the hybrid system. (→P.404)

#### **The interior lights and headlights are dim, or the horn does not sound or sounds at a low volume**

One of the following may be the cause of the problem:

- The 12-volt battery may be discharged. (→P.408)
- The 12-volt battery terminal connections may be loose or corroded. (→P.349)

#### **The interior lights and headlights do not turn on, or the horn does not sound**

One of the following may be the cause of the problem:

- The 12-volt battery may be discharged. (→P.408)
- One or both of the 12-volt battery terminals may be disconnected. (→P.349)

Contact your Toyota dealer if the problem cannot be repaired, or if repair procedures are unknown.

#### **Starting the hybrid system in an emergency**

When the hybrid system does not start, the following steps can be used as an interim measure to start the hybrid system if the power switch is functioning normally. Do not use this starting procedure except in cases of emergency.

- 1 Pull the parking brake switch to check that the parking brake is set. (→P.187)

Parking brake indicator will come on.

- 2 Shift the shift lever to P.
- 3 Turn the power switch to ACC.
- 4 Press and hold the power switch for about 15 seconds while depressing the brake pedal firmly.

Even if the hybrid system can be started using the above steps, the system may be malfunctioning. Have the vehicle inspected by your Toyota dealer.

## If you lose your keys

**New genuine keys can be made by your Toyota dealer using the other key and the key number stamped on your key number plate. Keep the plate in a safe place such as your wallet, not in the vehicle.**



### NOTICE

■ **When an electronic key is lost**

If the electronic key remains lost, the risk of vehicle theft increases significantly. Visit your Toyota dealer immediately with all remaining electronic keys that were provided with your vehicle.

### If the fuel filler door cannot be opened

If the fuel filler door opener switch cannot be operated, the following procedure can be used to open the fuel filler door.

#### Opening the fuel filler door

- 1 Remove the cover inside the luggage compartment by inserting a screwdriver.

When removing the cover, to prevent damage, cover the tip of the screwdriver with a rag.

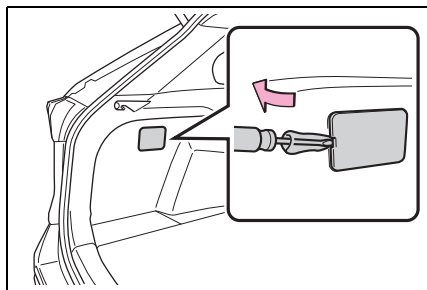

- 2 Pull the lever.

After removing the cover, pull the lever to unlock the fuel filler door and it will be ready to open as usual.

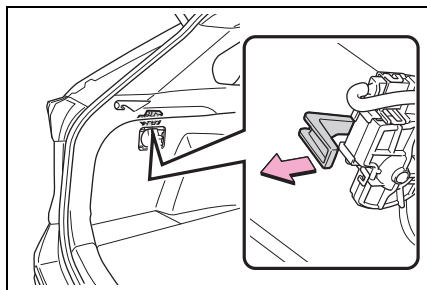

### If the electronic key does not operate properly

If communication between the electronic key and vehicle is interrupted (→P.131) or the electronic key cannot be used because the battery is depleted, the smart entry & start system and wireless remote control cannot be used. In such cases, the doors can be opened and the hybrid system can be started by following the procedure below.

#### ■ When the electronic key does not work properly

- Make sure that the smart entry & start system has not been deactivated in the customization setting. If it is off, turn the function on. (Customizable features: →P.434)
- Check if battery-saving mode is set. If it is set, cancel the function. (→P.131)
- The electronic key function may have stopped. (→P.131)

#### ⚠ NOTICE

#### ■ In case of a smart entry & start system malfunction, or other key related problems

Take your vehicle with all the electronic keys provided with your vehicle to your Toyota dealer.

#### Locking and unlocking the doors

Use the mechanical key (→P.114)



in order to perform the following operations.

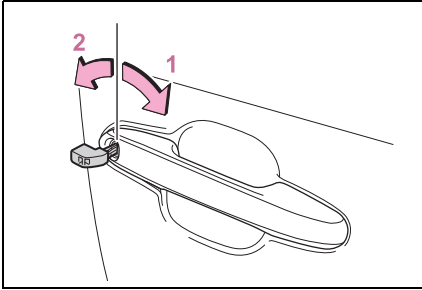

- 1 Locks all the doors
- 2 Unlocks all the doors

### ■ Key linked functions

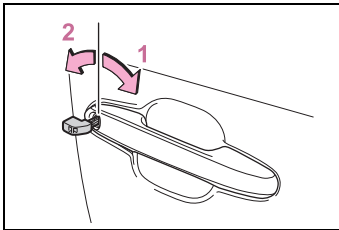

- 1 Closes the windows and the moon roof\*<sup>1</sup> (turn and hold)\*<sup>2</sup>
- 2 Opens the windows and the moon roof\*<sup>1</sup> (turn and hold)\*<sup>2</sup>

\*<sup>1</sup>: If equipped

\*<sup>2</sup>: These settings must be customized at your Toyota dealer.

### ! WARNING

- When using the mechanical key and operating the power windows or the moon roof (if equipped)

Operate the power window or the moon roof after checking to make sure that there is no possibility of any passenger having any of their body parts caught in the window or the moon roof. Also, do not allow children to operate the mechanical key. It is possible for children and other passengers to get caught in the power window or the moon roof.

### Starting the hybrid system

- 1 Ensure that the shift lever is in P and depress the brake pedal.
- 2 Touch the Toyota emblem side of the electronic key to the power switch.

When the electronic key is detected, a buzzer sounds and the power switch will turn to ON.

When the smart entry & start system is deactivated in customization setting, the power switch will turn to ACC.

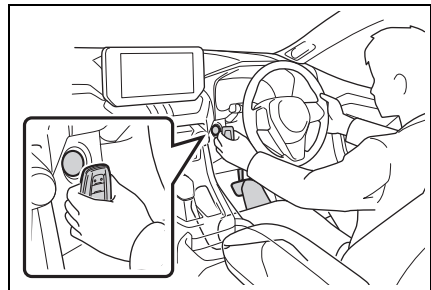

- 3 Firmly depress the brake pedal and check that  is displayed on the multi-information display.

- 4 Press the power switch shortly and firmly.

In the event that the hybrid system still cannot be started, contact your Toyota dealer.

**■ Stopping the hybrid system**

Shift the shift lever to P, set the parking brake and press the power switch as you normally do when stopping the hybrid system.

**■ Replacing the key battery**

As the above procedure is a temporary measure, it is recommended that the electronic key battery be replaced immediately when the battery is depleted. (→P.363)

**■ Changing power switch modes**

Release the brake pedal and press the power switch in step 3 above. The engine does not start and modes will be changed each time the switch is pressed. (→P.179)

**If the 12-volt battery is discharged**

The following procedures may be used to start the hybrid system if the vehicle's 12-volt battery is discharged.

You can also call your Toyota dealer or a qualified repair shop.

**Restarting the hybrid system**

If you have a set of jumper (or booster) cables and a second vehicle with a 12-volt battery, you can jump start your vehicle by following the steps below.

- 1 Open the hood (→P.339) and fuse box cover.

Push claws **A** and **B** to completely release the lock, and then lift up the cover.

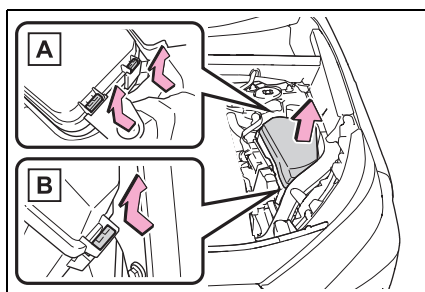

- 2 Open the exclusive jump starting terminal cover.

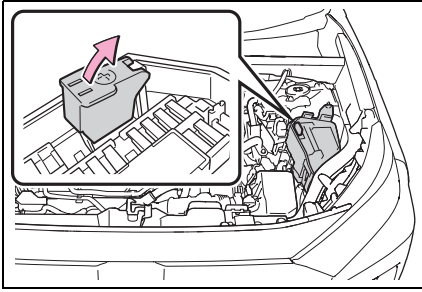

- 3 Connect a positive jumper cable clamp to **A** on your vehicle and connect the clamp on the other end of the positive cable to **B** on the second vehicle. Then, connect a negative cable clamp to **C** on the second vehicle and connect the clamp at the other end of the negative cable to **D**.

Use jumper cables that can reach the specified terminals and connecting point.

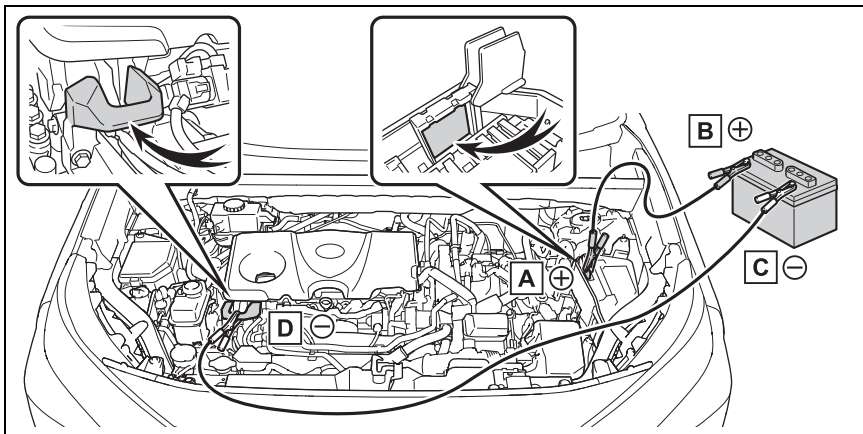

- A** Exclusive jump starting terminal (your vehicle)
- B** Positive (+) battery terminal (second vehicle)
- C** Negative (-) battery terminal (second vehicle)
- D** Metallic point shown in the illustration

- 4 Start the engine of the second vehicle. Increase the engine speed slightly and maintain at that level for approximately 5

minutes to recharge the 12-volt battery of your vehicle.

- 5 Maintain the engine speed of the second vehicle and start the hybrid system of your vehicle by turning the power switch to ON.
- 6 Make sure the “READY” indicator comes on. If the indicator light does not come on, contact your Toyota dealer.
- 7 Once the hybrid system has started, remove the jumper cables in the exact reverse order from which they were connected.
- 8 Close the exclusive jump starting terminal cover, and reinstall the fuse box cover to its original position.

Once the hybrid system starts, have the vehicle inspected at your Toyota dealer as soon as possible.

---

#### ■ Starting the hybrid system when the 12-volt battery is discharged

The hybrid system cannot be started by push-starting.

#### ■ To prevent 12-volt battery discharge

- Turn off the headlights and the audio system while the hybrid system is off.
- Turn off any unnecessary electrical components when the vehicle is running at a low speed for an extended period, such as in heavy traffic.

#### ■ When the 12-volt battery is removed or discharged

- Information stored in the ECU is cleared. When the 12-volt battery is depleted, have the vehicle inspected

at your Toyota dealer.

- Some systems may require initialization. (→P.442)

#### ■ When removing the 12-volt battery terminals

When the 12-volt battery terminals are removed, the information stored in the ECU is cleared. Before removing the 12-volt battery terminals, contact your Toyota dealer.

#### ■ Charging the 12-volt battery

The electricity stored in the 12-volt battery will discharge gradually even when the vehicle is not in use, due to natural discharge and the draining effects of certain electrical appliances. If the vehicle is left for a long time, the 12-volt battery may discharge, and the hybrid system may be unable to start. (The 12-volt battery recharges automatically while the hybrid system is operating.)

#### ■ When recharging or replacing the 12-volt battery

- In some cases, it may not be possible to unlock the doors using the smart entry & start system when the 12-volt battery is discharged. Use the wireless remote control or the mechanical key to lock or unlock the doors.
- The hybrid system may not start on the first attempt after the 12-volt battery has recharged but will start normally after the second attempt. This is not a malfunction.
- The power switch mode is memorized by the vehicle. When the 12-volt battery is reconnected, the system will return to the mode it was in before the 12-volt battery was discharged. Before disconnecting the 12-volt battery, turn the power switch to OFF. If you are unsure what mode the power switch was in before the 12-volt battery discharged, be especially careful when reconnecting the 12-volt battery.

#### ■ When replacing the 12-volt battery

- Use a 12-volt battery that conforms to

European regulations.

- Use a 12-volt battery that the case size is same as the previous one (LN1), 20 hours rate capacity (20HR) is equivalent (45Ah) or greater, and performance rating (CCA) is equivalent (285A) or greater.
- If the sizes differ, the 12-volt battery cannot be properly secured.
- If the 20 hour rate capacity is low, even if the time period where the vehicle is not used is a short time, the 12-volt battery may discharge and hybrid system may not be able to start.
- Use a ventilation type calcium battery
- Use a 12-volt battery with a handle. If a 12-volt battery without a handle is used, removal is more difficult.
- When removing the 12-volt battery: →P.348
- After replacing, firmly attach the following items to the exhaust hole of the 12-volt battery.
- Use the exhaust hose that was attached to the 12-volt battery before replacing and confirm that it is firmly connected to the hole section of the vehicle.
- Use the exhaust hole plug included with the new 12-volt battery or the one installed on the battery prior to the replacement. (Depending on the new 12-volt battery installed, the exhaust hole may be plugged.)

For details, consult your Toyota dealer.

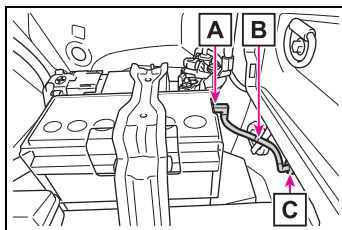

**A** Exhaust hole

**B** Exhaust hose

**C** Hole section of the vehicle

## WARNING

### ■ When removing the battery terminals

Always remove the negative (-) terminal first. If the positive (+) terminal contacts any metal in the surrounding area when the positive (+) terminal is removed, a spark may occur, leading to a fire in addition to electrical shocks and death or serious injury.

### ■ Avoiding 12-volt battery fires or explosions

Observe the following precautions to prevent accidentally igniting the flammable gas that may be emitted from the 12-volt battery:

- Make sure each jumper cable is connected to the correct terminal and that it is not unintentionally in contact with any other than the intended terminal.
- Do not allow the other end of the jumper cable connected to the “+” terminal to come into contact with any other parts or metal surfaces in the area, such as brackets or unpainted metal.
- Do not allow the + and - clamps of the jumper cables to come into contact with each other.
- Do not smoke, use matches, cigarette lighters or allow open flame near the 12-volt battery.

### ■ 12-volt battery precautions

The 12-volt battery contains poisonous and corrosive acidic electrolyte, while related parts contain lead and lead compounds. Observe the following precautions when handling the 12-volt battery:

- When working with the 12-volt battery, always wear safety glasses and take care not to allow any battery fluids (acid) to come into contact with skin, clothing or the vehicle body.

**WARNING**

- Do not lean over the 12-volt battery.
- In the event that 12-volt battery fluid comes into contact with the skin or eyes, immediately wash the affected area with water and seek medical attention.  
Place a wet sponge or cloth over the affected area until medical attention can be received.
- Always wash your hands after handling the 12-volt battery support, terminals, and other battery-related parts.
- Do not allow children near the 12-volt battery.

■ **After recharging the 12-volt battery**

Have the 12-volt battery inspected at your Toyota dealer as soon as possible.

If the 12-volt battery is deteriorating, continued use may cause the 12-volt battery to emit a malodorous gas, which may be detrimental to the health of passengers.

■ **When replacing the 12-volt battery**

- For information regarding 12-volt battery replacement, contact your Toyota dealer.

- After replacing, securely attach the exhaust hose and exhaust hole plug to the exhaust hole of the replaced 12-volt battery. If not properly installed, gases (hydrogen) may leak into the vehicle interior, and there is the possible danger of the gas igniting and exploding.

**NOTICE**

■ **When handling jumper cables**

When connecting the jumper cables, ensure that they do not become entangled in the cooling fan, etc.

■ **When connecting jumper cables**

Make sure to connect jumper cables to the specified terminals and connecting point. Failure to do so may adversely affect the electronic devices or damage to them.

■ **To prevent damaging the vehicle**

The exclusive jump starting terminal is to be used when charging the 12-volt battery from another vehicle in an emergency. It cannot be used to jump start another vehicle.

## If your vehicle overheats

The following may indicate that your vehicle is overheating.

- The engine coolant temperature gauge (→P.78, 83) shows the red zone or a loss of hybrid system power is experienced. (For example, the vehicle speed does not increase.)
- “Engine Coolant Temp High Stop in a Safe Place See Owner’s Manual” or “Hybrid System Overheated Output Power Reduced” is shown on the multi-information display.
- Steam comes out from under the hood.

## Correction procedures

- **If the engine coolant temperature gauge enters the red zone or “Engine Coolant Temp High Stop in a Safe Place See Owner’s Manual” is shown on the multi-information display**

- 1 Stop the vehicle in a safe place and turn off the air conditioning system, and then stop the hybrid system.
- 2 If you see steam:  
Carefully lift the hood after the steam subsides.  
If you do not see steam:  
Carefully lift the hood.

- 3 After the hybrid system has cooled down sufficiently, inspect the hoses and radiator core (radiator) for any leaks.

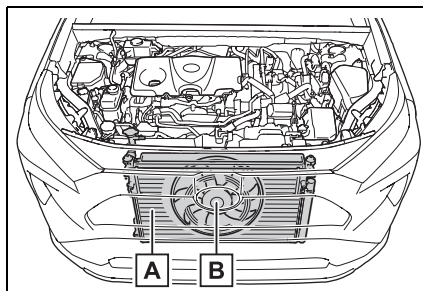

- A** Radiator
- B** Cooling fan

If a large amount of coolant leaks, immediately contact your Toyota dealer.

- 4 The coolant level is satisfactory if it is between the “FULL” and “LOW” lines on the reservoir.

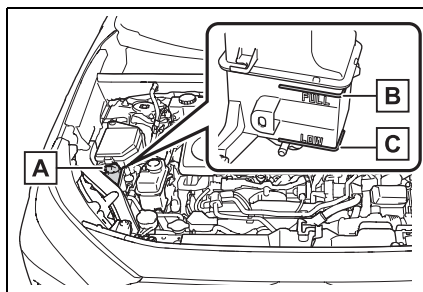

- A** Reservoir
- B** “FULL” line
- C** “LOW” line

- 5 Add coolant if necessary.

Water can be used in an emergency if engine coolant is unavailable. If water was added in an emergency, have the vehicle inspected at your

Toyota dealer as soon as possible.

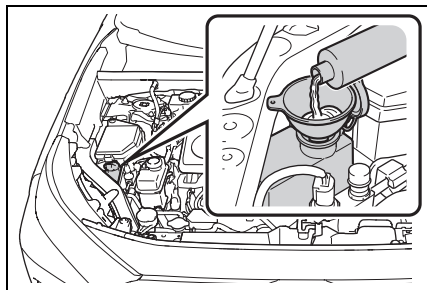

- 6 Start the hybrid system and turn the air conditioning system on to check that the radiator cooling fan operates and to check for coolant leaks from the radiator or hoses.

The fan operates when the air conditioning system is turned on immediately after a cold start. Confirm that the fan is operating by checking the fan sound and air flow. If it is difficult to check these, turn the air conditioning system on and off repeatedly. (The fan may not operate in freezing temperatures.)

- 7 If the fan is not operating:  
Stop the hybrid system immediately and contact your Toyota dealer.

If the fan is operating:  
Have the vehicle inspected at the nearest Toyota dealer.

- 8 Check if “Engine Coolant Temp High Stop in a Safe Place See Owner’s Manual” is shown on the multi-information display.  
If the message does not disappear:  
Stop the hybrid system and contact your Toyota dealer.  
If the message is not displayed:

Have the vehicle inspected at the nearest Toyota dealer.

■ If “Hybrid System Overheated Output Power Reduced” is shown on the multi-information display

- 1 Stop the vehicle in a safe place.
- 2 Stop the hybrid system and carefully lift the hood.
- 3 After the hybrid system has cooled down, inspect the hoses and radiator core (radiator) for any leaks.

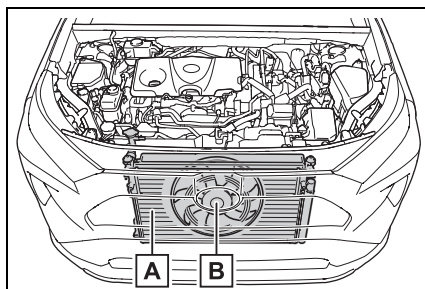

- A Radiator
- B Cooling fan

If a large amount of coolant leaks, immediately contact your Toyota dealer.



- 4 The coolant level is satisfactory if it is between the “FULL” and “LOW” lines on the reservoir.

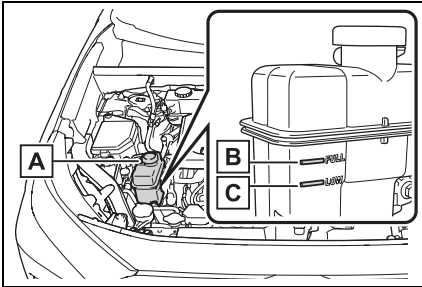

- A** Reservoir  
**B** “FULL” line  
**C** “LOW” line

- 5 Add coolant if necessary.

Water can be used in an emergency if power control unit coolant is unavailable.

If water was added in an emergency, have the vehicle inspected at your Toyota dealer as soon as possible.

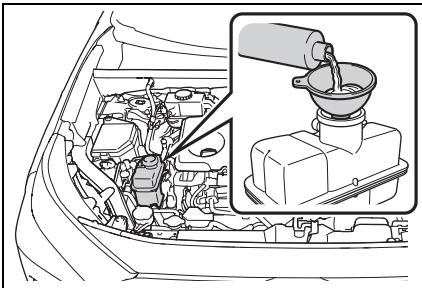

- 6 After stopping the hybrid system and waiting for 5 minutes or more, start the hybrid system again and check for the multi-information display.

If the message does not disappear:  
 Stop the hybrid system and contact your Toyota dealer.

If the message is not displayed: The

hybrid system temperature has dropped and the vehicle may be driven normally.

However, if the message appears again frequently, contact your Toyota dealer.

**⚠ WARNING**

**■ When inspecting under the hood of your vehicle**

Observe the following precautions. Failure to do so may result in serious injury such as burns.

- If steam is seen coming from under the hood, do not open the hood until the steam has subsided. The engine compartment may be very hot.
- After the hybrid system has been turned off, check that the “READY” indicator is off. When the hybrid system is operating, the gasoline engine may automatically start, or the cooling fan may suddenly operate even if the gasoline engine stops. Do not touch or approach rotating parts such as the fan, which may lead to fingers or clothing (especially a tie, a scarf or a muffler) getting caught, resulting in serious injury.
- Do not loosen the coolant reservoir cap while the hybrid system and radiator are hot. High temperature steam or coolant could spray out.

**⚠ NOTICE**

**■ When adding engine/power control unit coolant**

Add coolant slowly after the hybrid system has cooled down sufficiently. Adding cool coolant to a hot hybrid system too quickly can cause damage to the hybrid system.



**NOTICE**

**To prevent damage to the cooling system**

Observe the following precautions:

- Avoid contaminating the coolant with foreign matter (such as sand or dust, etc.).
- Do not use any coolant additive.

**If the vehicle becomes stuck**

**Carry out the following procedures if the tires spin or the vehicle becomes stuck in mud, dirt or snow:**

**Recovering procedure**

- 1 Stop the hybrid system. Set the parking brake and shift the shift lever to P.
- 2 Remove the mud, snow or sand from around the stuck tire.
- 3 Place wood, stones or some other material to help provide traction under the tires.
- 4 Restart the hybrid system
- 5 Shift the shift lever to D or R and release the parking brake. Then, while exercising caution, depress the accelerator pedal.

**When it is difficult to free the vehicle**

Press  to turn off TRC. (→P.282)

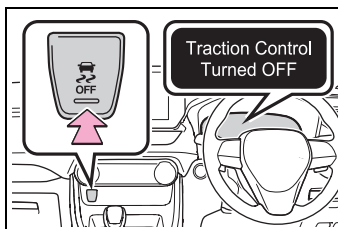

**WARNING****■ When attempting to free a stuck vehicle**

If you choose to push the vehicle back and forth to free it, make sure the surrounding area is clear to avoid striking other vehicles, objects or people. The vehicle may also lunge forward or lunge back suddenly as it becomes free. Use extreme caution.

**■ When shifting the shift lever**

Be careful not to shift the shift lever with the accelerator pedal depressed. This may lead to unexpected rapid acceleration of the vehicle that may cause an accident resulting in death or serious injury.

**NOTICE****■ To avoid damaging the transmission and other components**

- Avoid spinning the wheels and depressing the accelerator pedal more than necessary.
- If the vehicle remains stuck even after these procedures are performed, the vehicle may require towing to be freed.



# Vehicle specifications

## 8

### 8-1. Specifications

Maintenance data (fuel, oil level, etc.) .....420

Fuel information .....428

### 8-2. Customization

Customizable features .....429

### 8-3. Initialization

Items to initialize .....442

## Maintenance data (fuel, oil level, etc.)

### Dimensions

Overall length* <sup>1</sup>		4600 mm (181.1 in.) <sup>*2</sup>
		4610 mm (181.5 in.) <sup>*3</sup>
Overall width* <sup>1</sup>		1855 mm (73.0 in.) <sup>*2</sup>
		1865 mm (73.4 in.) <sup>*3</sup>
Overall height* <sup>1</sup>		1685 mm (66.3 in.) <sup>*4</sup>
		1690 mm (66.5 in.) <sup>*5</sup>
Wheelbase* <sup>1</sup>		2690 mm (105.9 in.)
Tread* <sup>1</sup>	Front	1605 mm (63.2 in.) <sup>*4</sup>
		1595 mm (62.8 in.) <sup>*5</sup>
	Rear	1625 mm (64.0 in.) <sup>*4</sup>
		1615 mm (63.6 in.) <sup>*5</sup>

\*1: Unladen vehicle

\*2: Except for AXAH54R-ANXVBQ models\*<sup>6</sup>

\*3: For AXAH54R-ANXVBQ models\*<sup>6</sup>

\*4: Vehicles without 235/55R19 tires

\*5: Vehicles with 235/55R19 tires

\*6: The model code is indicated on the manufacturer's label. (→P.420)

### Vehicle identification

#### ■ Vehicle identification number

The vehicle identification number (VIN) is the legal identifier for your vehicle. This is the primary identification number for your Toyota. It is used in registering the ownership of your vehicle.

This number is also on the manufacturer's label.

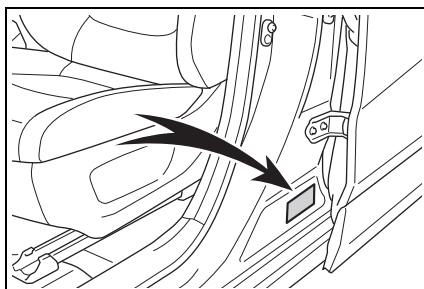

This number is also stamped under the right-hand front seat.

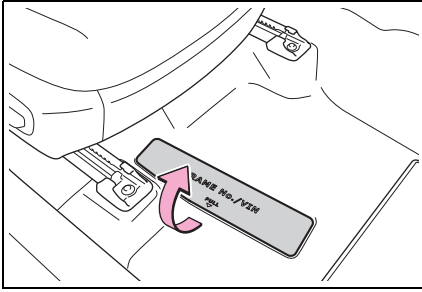

### ■ Engine number

The engine number is stamped on the engine block as shown.

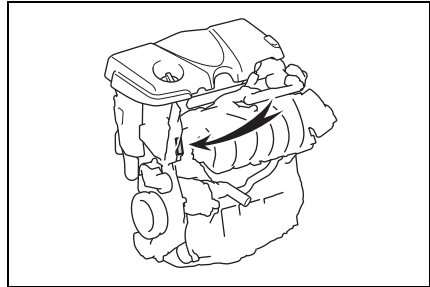

## Engine

Model	A25A-FXS
Type	4-cylinder in line, 4-cycle, gasoline
Bore and stroke	87.50 × 103.48 mm (3.44 × 4.07 in.)
Displacement	2487 cm <sup>3</sup> (151.8 cu. in.)
Valve clearance	Automatic adjustment

## Fuel

Fuel type	Unleaded gasoline only
Research Octane Number	91 or higher
Fuel tank capacity (Reference)	55 L (14.5 gal., 12.1 Imp.gal.)

## Electric motor (traction motor)

### ► Front

Type	Permanent magnet synchronous motor
Maximum output	88 kW
Maximum torque	202 N•m (20.6 kgf•m, 149 ft•lbf)

## ▶ Rear (AWD models)

Type	Permanent magnet synchronous motor
Maximum output	40 kW
Maximum torque	121 N•m (12.3 kgf•m, 89.2 ft•lbf)

**Hybrid battery (traction battery)**

Type	Nickel-Metal hydride battery
Voltage	7.2 V/module
Capacity	6.5 Ah (3HR)
Quantity	34 modules
Nominal voltage	244.8 V

**Lubrication system**■ **Oil capacity (Drain and refill — reference\*)**

With filter	4.3 L (4.5 qt., 3.8 Imp. qt.)
Without filter	4.0 L (4.2 qt., 3.5 Imp. qt.)

\*: The engine oil capacity is a reference quantity to be used when changing the engine oil. When actually adding the engine oil, make sure that the oil level is between the low level mark and refill upper limit mark (→P.344). Warm up the engine and turn off the hybrid system, wait about 5 minutes, and check the oil level on the dipstick.

■ **Engine oil selection**

“Toyota Genuine Motor Oil” is used in your Toyota vehicle. Use Toyota approved “Toyota Genuine Motor Oil” or equivalent to satisfy the following grade and viscosity.

Oil grade:

0W-16:

API grade SN “Resource-Conserving”, SN PLUS “Resource-Conserving” or SP “Resource-Conserving”; or ILSAC GF-6B multigrade engine

oil

0W-20, 5W-20, 5W-30 and 10W-30:

API grade SL “Energy-Conserving”, SM “Energy-Conserving”, SN “Resource-Conserving”, SN PLUS “Resource-Conserving” or SP “Resource-Conserving”; or ILSAC GF-6A multigrade engine oil

Recommended viscosity (SAE):

SAE 0W-16 is filled into your Toyota vehicle at manufacturing,



and the best choice for good fuel economy and good starting in cold weather.

If you use SAE 10W-30 or a higher viscosity engine oil in extremely low temperatures, the engine may become difficult to start, so SAE 0W-16, 0W-20, 5W-20 or 5W-30 engine oil is recommended.

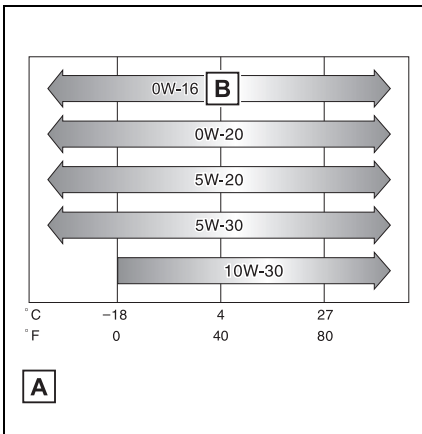

**A** Temperature range anticipated before next oil change

**B** Preferred

Oil viscosity (0W-16 is explained here as an example):

- The 0W in 0W-16 indicates the characteristic of the oil which allows cold startability. Oils with a lower value before the W allow for easier starting of the engine in cold weather.
- The 16 in 0W-16 indicates the viscosity characteristic of the oil when the oil is at high temperature. An oil with a higher viscosity (one with a higher value) may

be better suited if the vehicle is operated at high speeds, or under extreme load conditions.

How to read oil container labels:

Either or both API registered marks are added to some oil containers to help you select the oil you should use.

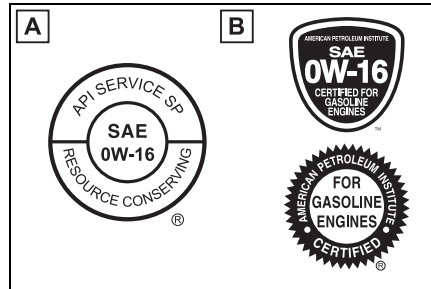

**A** API Service Symbol

Top portion: “API SERVICE SP” means the oil quality designation by American Petroleum Institute (API).

Center portion: “SAE 0W-16” means the SAE viscosity grade.

Lower portion: “Resource-Conserving” means that the oil has fuel-saving and environmental protection capabilities.

**B** ILSAC Certification Mark

The International Lubricant Specification Advisory Committee (ILSAC) Certification Mark is displayed on the front of the container.

## Cooling system

Capacity *	Gasoline engine	6.1 L (6.4 qt., 5.4 Imp. qt.)
	Power control unit	1.6 L (1.7 qt., 1.4 Imp. qt.)
Coolant type	Use either of the following: <ul style="list-style-type: none"> <li>• “Toyota Super Long Life Coolant”</li> <li>• Similar high-quality ethylene glycol-based non-silicate, non-amine, non-nitrite, and non-borate coolant with long-life hybrid organic acid technology</li> </ul> Do not use plain water alone.	

\*: The coolant capacity is the quantity of reference.  
If replacement is necessary, contact your Toyota dealer.

## Ignition system (spark plug)

Make	DENSO FC16HR-Q8
Gap	0.8 mm (0.031 in.)



### NOTICE

#### ■ Iridium-tipped spark plugs

Use only iridium-tipped spark plugs. Do not adjust the spark plug gap.

## Electrical system (12-volt Battery)

Specific voltage reading at 20°C (68°F):	12.0 V or higher (Turn the power switch to OFF and turn on the high beam headlights for 30 seconds.) If the voltage is lower than the standard value, charge the 12-volt battery.	
Charging rates	Quick charge	15 A max.
	Slow charge	5 A max.

## Hybrid transmission

Fluid capacity *	3.9 L (4.1 qt., 3.4 Imp. qt.)
Fluid type	Toyota Genuine ATF WS

- \*: The fluid capacity is the quantity of reference.  
If replacement is necessary, contact your Toyota dealer.

**NOTICE****Hybrid transmission fluid type**

Using transmission fluid other than the above type may cause abnormal noise or vibration, or ultimately damage the transmission of your vehicle.

**Rear differential (rear electric motor) (AWD models)**

Fluid capacity*	1.7 L (1.8 qt., 1.5 Imp. qt.)
Fluid type	Toyota Genuine ATF WS

- \*: The fluid capacity is the quantity of reference.  
If replacement is necessary, contact your Toyota dealer.

**NOTICE****Rear differential fluid type**

Using transmission fluid other than the above type may cause abnormal noise or vibration, or ultimately damage the transmission of your vehicle.

**Brakes**

Pedal clearance*	146 mm (5.7 in.) Min.
Pedal free play	1.0 — 6.0 mm (0.04 — 0.24 in.)
Fluid type	SAE J1703 or FMVSS No. 116 DOT 3 SAE J1704 or FMVSS No. 116 DOT 4

- \*: Minimum pedal clearance when depressed with a force of 300 N (30.5 kgf, 67.4 lbf) while the hybrid system is operating.

**Steering**

Free play	Less than 30 mm (1.2 in.)
-----------	---------------------------

## Tires and wheels

### ■ Full-size tire

#### ▶ Type A

Tire size		225/65R17 102H
Tire inflation pressure (Recommended cold tire inflation pressure)	Front	230 kPa (2.3 kgf/cm <sup>2</sup> or bar, 33 psi)
	Rear	230 kPa (2.3 kgf/cm <sup>2</sup> or bar, 33 psi)
Wheel size		17 × 7J
Wheel nut torque		103 N•m (10.5 kgf•m, 76 ft•lbf)

#### ▶ Type B

Tire size		225/60R18 100H
Tire inflation pressure (Recommended cold tire inflation pressure)	Front	230 kPa (2.3 kgf/cm <sup>2</sup> or bar, 33 psi)
	Rear	230 kPa (2.3 kgf/cm <sup>2</sup> or bar, 33 psi)
Wheel size		18 × 7J
Wheel nut torque		103 N•m (10.5 kgf•m, 76 ft•lbf)

#### ▶ Type C

Tire size		235/55R19 101V
Tire inflation pressure (Recommended cold tire inflation pressure)	Front	230 kPa (2.3 kgf/cm <sup>2</sup> or bar, 33 psi)
	Rear	230 kPa (2.3 kgf/cm <sup>2</sup> or bar, 33 psi)
Wheel size		19 × 7 1/2J
Wheel nut torque		103 N•m (10.5 kgf•m, 76 ft•lbf)

### ■ Compact spare tire (if equipped)

#### ▶ Type A

Tire size	T165/80D17 104M
Tire inflation pressure (Recommended cold tire inflation pressure)	420 kPa (4.2 kgf/cm <sup>2</sup> or bar, 60 psi)
Wheel size	17 × 4T
Wheel nut torque	103 N•m (10.5 kgf•m, 76 ft•lbf)

#### ▶ Type B

Tire size	T165/90D18 107M
Tire inflation pressure (Recommended cold tire inflation pressure)	420 kPa (4.2 kgf/cm <sup>2</sup> or bar, 60 psi)
Wheel size	18 × 4T
Wheel nut torque	103 N•m (10.5 kgf•m, 76 ft•lbf)

### Light bulbs

Light bulbs	W	Type
Rear turn signal lights	21	A
Back-up lights	16	B
Outer foot lights*	5	B

A: Wedge base bulbs (amber)

B: Wedge base bulbs (clear)

\*: If equipped

## Fuel information

**You must only use unleaded gasoline in your vehicle.**

**For optimum engine performance, select unleaded gasoline with a Research Octane Number of 91 or higher.**

### ■ Use of ethanol blended gasoline in a gasoline engine

Toyota allows the use of ethanol blended gasoline where the ethanol content is up to 10%. Make sure that the ethanol blended gasoline to be used has a Research Octane Number that follows the above.

### ■ If your engine knocks

- Consult your Toyota dealer.
- You may occasionally notice light knocking for a short time while accelerating or driving uphill. This is normal and there is no need for concern.



### NOTICE

#### ■ Notice on fuel quality

- Do not use improper fuels. If improper fuels are used, the engine will be damaged.
- Do not use gasoline with metallic additives, for example manganese, iron or lead, otherwise it may cause damage on your engine or emission control system.
- Do not add aftermarket fuel additives which contain metallic additives.
- Do not use the methanol blended gasoline such as M15, M85, M100. The use of gasoline containing methanol may cause engine damage or failure.

## Customizable features



Your vehicle includes a variety of electronic features that can be personalized to suit your preferences. The settings of these features can be changed using the multi-information display, navigation/multimedia system, or at your Toyota dealer.

## Customizing vehicle features

### ■ Changing using the Multimedia Display





- 1 Select  on the main menu.
- 2 Select "Vehicle customize" on the sub menu.
- 3 Select the item to change the settings of from the list.



Various setting can be changed. Refer to the list of settings that can be changed for details.

For functions that can be turned on/off, select  (ON)/  (OFF).

The settings, such as the volume and sensor sensitivity can be changed by dragging the round icon on the display.

### ■ Changing using the multi-information display (with 7-inch display)









- 1 Press  or  of the meter control switches and select .
- 2 Press  or  of the meter control switches, select the item.

- 3 To switch the function on and off, press  to switch to the desired setting.
- 4 To perform detailed setting of functions that support detailed settings, press and hold  and display the setting screen.

The method of performing detailed setting differs for each screen. Please refer to the advice sentence displayed on the screen.

To go back to the previous screen or exit the customize mode, press .

### ■ Changing using the multi-information display (with 12.3-inch display)

- 1 Press and hold  to display the cursor on the content display area (center) of the multi-information display.
- 2 Press  or  of the meter control switches to select  and press .
- 3 Press  or  of the meter control switches, select the item.
- 4 To switch the function on and off, press  to switch to the desired setting.
- 5 To perform detailed setting of functions that support detailed settings, press and hold  and display the setting screen.

The method of performing detailed setting differs for each screen. Please refer to the advice sentence displayed on the screen.

To go back to the previous screen or exit the customize mode, press .

**■ When customizing using the navigation/multimedia system or multi-information display**

Stop the vehicle in a safe place, apply the parking brake, and shift the shift lever to P. Also, to prevent 12-volt battery discharge, leave the hybrid system operating while customizing the features.

 **WARNING**

**■ During customization**

As the hybrid system needs to be operating during customization, ensure that the vehicle is parked in a place with adequate ventilation. In a closed area such as a garage, exhaust gases including harmful carbon monoxide (CO) may collect and enter the vehicle. This may lead to death or a serious health hazard.

 **NOTICE**

**■ During customization**

To prevent 12-volt battery discharge, ensure that the hybrid system is operating while customizing features.

**Customizable Features**

Some function settings are changed simultaneously with other functions being customized. Contact your Toyota dealer for further details.

**A** Vehicles with navigation system or multimedia system: Settings that can be changed using the navigation system or multimedia system

**B** Settings that can be changed using the multi-information display

**C** Settings that can be changed by your Toyota dealer

Definition of symbols: O = Available, – =Not available

**■ Gauges, meters and multi-information display (with 7-inch display) (→P.78, 88)**

Function *1	Default setting	Customized setting	<b>A</b>	<b>B</b>	<b>C</b>
Language	English	French	–	O	–
Units	L/100 km	km/L	–	O	–
Speedometer display	Analog	Digital	–	O	–
EV indicator	On	Off	–	O	–
“Eco Guidance” (ECO Accelerator Guidance)	On	Off	–	O	–



Function *1	Default setting	Customized setting	A	B	C
"Fuel Economy"	"Total Average"	"Trip Average"	-	O	-
		"Tank Average"			
Audio system linked display	On	Off	-	O	-
Energy monitor	On	Off	-	O	-
AWD system display*2	On	Off	-	O	-
Drive information type	Trip	Total	-	O	-
Drive information items (first item)	Distance	Average Speed	-	O	-
		Total Time			
Drive information items (second item)	Total Time	Average Speed	-	O	-
		Distance			
"Trip Summary"	"ECO Guidance"	"Drive Info"	-	O	-
Pop-up display	On	Off	-	O	-
Multi-Information display off	Off	On	-	O	-
Convenience Services (Suggestion function)	On	On (when the vehicle is stopped)	O	-	O
		Off			

\*1: For details about each function: →P.94

\*2: AWD models only

### ■ Gauges, meters and multi-information display (with 12.3-inch display) (→P.83, 98)

Function *1	Default setting	Customized setting	A	B	C
Language	English	French	-	O	-
Units*2	L/100 km	km/L	-	O	-

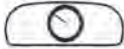
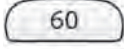
Function *1	Default setting	Customized setting	A	B	C
Meter Type		 *3	-	O	-
		 *3			
Meter Style	smart	casual	-	O	-
		tough			
		sporty			
Tachometer display*4	Hybrid system indicator	Speedometer	-	O	-
EV indicator	On	Off	-	O	-
Fuel Economy	The average fuel economy since the function was reset	The average fuel economy after starting	-	O	-
ECO Guidance (ECO Accelerator Guidance)	On	Off	-	O	-
Drive information items (top row)*5	Distance	Average Speed	-	O	-
		Total Time			
Drive information items (bottom row)*5	Total Time	Average Speed	-	O	-
		Distance			
TRIP A Items (top row)*5	Distance	Average Speed	-	O	-
		Total Time			
TRIP A Items (bottom row)*5	Average Speed	Total Time	-	O	-
		Distance			
TRIP B Items (top row)*5	Distance	Average Speed	-	O	-
		Total Time			
TRIP B Items (bottom row)*5	Average Speed	Total Time	-	O	-
		Distance			
Pop-up display	On	Off	-	O	-

Function *1	Default setting	Customized setting	A	B	C
Adjust Meter Brightness	Standard	User setting	–	O	–
Convenience Services (Suggestion function)	On	On (when the vehicle is stopped)	O	–	O
		Off			

\*1: For details about each function: →P.103

\*2: The default setting varies according to country.

\*3: The on/off operation of the widget can be changed.

\*4: The setting may not be changed depending on currently selected meter type.

\*5: The same item cannot be displayed on the top row and bottom row.

### ■ Door lock (→P.115, 406)

Function	Default setting	Customized setting	A	B	C
Unlocking using a mechanical key	All doors unlocked in first step	Driver's door unlocked in first step, all doors unlocked in second step	–	–	O
Speed linked door locking function	On	Off	O	–	O
Shift position linked door locking function	Off	On	O	–	O
Shift position linked door unlocking function	Off	On	O	–	O
Driver's door linked door unlocking function	On	Off	O	–	O

### ■ Rear seat reminder (→P.117)

Function	Default setting	Customized setting	A	B	C
Rear seat reminder function	On	Off	–	O	–

### ■ Smart entry & start system and wireless remote control (→P.113, 129)

Function	Default setting	Customized setting	A	B	C
			<input type="radio"/>	<input type="radio"/>	<input type="radio"/>
Operation signal (emergency flashers)	On	Off	<input type="radio"/>	<input type="radio"/>	<input type="radio"/>
Operation buzzer volume	5	Off	<input type="radio"/>	<input type="radio"/>	<input type="radio"/>
		1 to 7	<input type="radio"/>	<input type="radio"/>	<input type="radio"/>
Time elapsed before the automatic door lock function is activated if a door is not opened after being unlocked	30 seconds	60 seconds	<input type="radio"/>	<input type="radio"/>	<input type="radio"/>
		120 seconds	<input type="radio"/>	<input type="radio"/>	<input type="radio"/>
Open door reminder buzzer (When locking the vehicle)	On	Off	<input type="radio"/>	<input type="radio"/>	<input type="radio"/>

### ■ Smart entry & start system (→P.129)

Function	Default setting	Customized setting	A	B	C
			<input type="radio"/>	<input type="radio"/>	<input type="radio"/>
Smart entry & start system	On	Off	<input type="radio"/>	<input type="radio"/>	<input type="radio"/>
Smart door unlocking	All the doors	Driver's door	<input type="radio"/>	<input type="radio"/>	<input type="radio"/>
Number of consecutive door lock operations	2 times <sup>*1</sup>	As many as desired <sup>*1</sup>	<input type="radio"/>	<input type="radio"/>	<input type="radio"/>
	As many as desired <sup>*2</sup>	2 times <sup>*2</sup>	<input type="radio"/>	<input type="radio"/>	<input type="radio"/>
Time elapsed before unlocking all the door when gripping and holding the driver's door handle <sup>*3</sup>	Off	1.5 seconds	<input type="radio"/>	<input type="radio"/>	<input type="radio"/>
		2 seconds	<input type="radio"/>	<input type="radio"/>	<input type="radio"/>
		2.5 seconds	<input type="radio"/>	<input type="radio"/>	<input type="radio"/>

\*1: For vehicles without double locking system

\*2: For vehicles with double locking system

\*3: This setting can be changed when the smart door unlocking setting is set to "Driver's door".

### ■ Wireless remote control (→P.113)

Function	Default setting	Customized setting	A	B	C
Wireless remote control	On	Off	-	-	0
Unlocking operation	All doors unlocked in first step	Driver's door unlocked in first step, all doors unlocked in second step	0	-	0
The function that activates the  switch of the wireless remote control when locking the door* (→P.123)	Off	On (Unlocking all the door)	-	-	0
		On (Unlocking back door only)	-	-	0

\*: If equipped

### ■ Power back door\*<sup>1</sup> (→P.123)

Function	Default setting	Customized setting	A	B	C
Power back door operations	On	Off	-	0	-
Operations of the power back door switch on the instrument panel	Press and hold	One short press	-	-	0
 switch of the wireless remote control operation	Press and hold	One short press	-	-	0
		Push twice	-	-	0
		Off	-	-	0
Operation buzzer volume	3	1	-	0	-
		2	-	0	-
Operation buzzer while the back door is operating* <sup>2</sup>	On	Off	-	-	0
Opening angle	5	1 to 4	-	0	-
		User setting* <sup>3</sup>	-	0	-
Power back door open operation when the back door opener switch is pressed	On	Off	-	-	0
Back door closing assist	On	Off	-	-	0

\*1: If equipped

\*2: The operation buzzer that sounds when the back door begins to operate cannot be turned off.

\*3: The open position is set by the power back door switch. (→P.128)

■ **Driving position memory\*** (→P.137)

Function	Default setting	Customized setting	A	B	C
Function to prevent contact between the head restraint and ceiling (while moving to memory location)	On	Off	-	-	O

\*: If equipped

■ **Outside rear view mirrors** (→P.153)

Function	Default setting	Customized setting	A	B	C
Automatic folding and extending operation*	Linked to locking/unlocking of the doors	Off	-	-	O
		Linked to power switch operation			

\*: If equipped

■ **Power windows, and moon roof\*** (→P.155, 158)

Function	Default setting	Customized setting	A	B	C
Key linked operation (open)	Off	On	-	-	O
Key linked operation (close)	Off	On	-	-	O
Wireless remote control linked operation (open)	Off	On	-	-	O
Wireless remote control linked operation (close)	Off	On	-	-	O
Wireless remote control linked operation signal (buzzer)	On	Off	-	-	O
Side windows open warning function	On	Off	-	-	O
Sliding roof open warning function	On	Off	-	-	O

\*: If equipped

## ■ Moon roof\* (→P.158)

Function	Default setting	Customized setting	A	B	C
			<input type="checkbox"/>	<input type="checkbox"/>	<input type="checkbox"/>
Automatic mode	On	Off	-	-	O
Opening direction when using the key linked operation	Slide	Tilt up	-	-	O
Opening direction when using the wireless remote control-linked operation	Slide	Tilt up	-	-	O

\*: If equipped

## ■ Lights (→P.193)

Function	Default setting	Customized setting	A	B	C
			<input type="checkbox"/>	<input type="checkbox"/>	<input type="checkbox"/>
Light reminder buzzer	On	Off	-	-	O

## ■ Automatic light control system (→P.193)

Function	Default setting	Customized setting	A	B	C
			<input type="checkbox"/>	<input type="checkbox"/>	<input type="checkbox"/>
Light sensor sensitivity	Standard	Brighter			
		Bright	O	-	O
		Dark			
		Darker			
Time elapsed before headlights automatically turn off after doors are closed	30 seconds	Off			
		60 seconds	O	-	O
		90 seconds			
Time elapsed before headlights automatically turn on*	Standard	Long	-	-	O

\*: If equipped

### ■ Rear window wiper (→P.201)

Function	Default setting	Customized setting	A	B	C
Back door opening linked rear window wiper stop function	Off	On	-	-	O
Washer linked rear window wiper operation	On	Off	-	-	O
Shift position linked rear window wiper operation (→P.201)	Only once	Off	-	-	O
		Continuous			

### ■ PCS (Pre-Collision System)\*<sup>1</sup> (→P.210)

Function	Customized setting	A	B	C
PCS (Pre-Collision System)* <sup>2</sup>	On, Off	-	O	-
Adjust alert timing	Early, Middle, Late	-	O	-

\*<sup>1</sup>: If equipped

\*<sup>2</sup>: The system is automatically enabled each time the power switch is turned to ON.

### ■ LTA (Lane Tracing Assist)\* (→P.220)

Function	Customized setting	A	B	C
Lane centering function	On, Off	-	O	-
Alert sensitivity	High, Standard	-	O	-
Vehicle sway warning function	On, Off	-	O	-
Vehicle sway warning sensitivity	High, Standard, Low	-	O	-

\*: If equipped

### ■ RSA (Road Sign Assist)\*<sup>1</sup> (→P.231)

Function	Customized setting	A	B	C
RSA (Road Sign Assist)* <sup>2</sup>	On, Off	-	O	-
Excess speed notification method* <sup>3</sup>	No notification, Display only, Display and buzzer	-	O	-
Excess speed notification level	1 km/h (1 mph), 3 km/h (2 mph), 5 km/h (3 mph)	-	O	-

\*<sup>1</sup>: If equipped



\*2: The system is automatically enabled each time the power switch is turned to ON.

\*3: If a Speed limit with supplemental mark is exceeded, the notification buzzer does not operate.

### ■ Dynamic radar cruise control with full-speed range\* (→P.234)

Function	Customized setting	A	B	C
Dynamic Radar Cruise Control with Road Sign Assist*	On, Off	-	O	-

\*: If equipped

### ■ BSM (Blind Spot Monitor)\* (→P.249)

Function	Default setting	Customized setting	A	B	C
BSM (Blind Spot Monitor)	On	Off	-	O	-
Outside rear view mirror indicator brightness	Bright	Dim	-	O	-
Alert timing for presence of approaching vehicle (sensitivity)	Intermediate	Early	-	O	-
		Late			
		Only when vehicle detected in blind spot			

\*: If equipped

### ■ RCTA (Rear Crossing Traffic Alert) function\*<sup>1</sup> (→P.263)

Function	Default setting	Customized setting	A	B	C
RCTA (Rear Crossing Traffic Alert) function	On	Off	-	O	-
Buzzer volume* <sup>2</sup>	Level 2	Level 1	-	O	-
		Level 3			

\*<sup>1</sup>: If equipped

\*<sup>2</sup>: This setting is linked with the buzzer volume of the Toyota parking assist-sensor.

### ■ Toyota parking assist-sensor\*<sup>1</sup> (→P.253)

Function	Default setting	Customized setting	A	B	C
Toyota parking assist-sensor	On	Off	–	○	○
Buzzer volume* <sup>2</sup>	2	1	–	○	○
		3			

\*<sup>1</sup>: If equipped

\*<sup>2</sup>: This setting is linked with the buzzer volume of the RCTA (Rear Crossing Traffic Alert) function.

### ■ PKSB (Parking Support Brake)\* (→P.268)

Function	Default setting	Customized setting	A	B	C
PKSB (Parking Support Brake) function	On	Off	–	○	–

\*: If equipped

### ■ Automatic air conditioning system (→P.298)

Function	Default setting	Customized setting	A	B	C
Switching between outside air and recirculated air mode linked to "AUTO" switch operation	On	Off	○	–	○
A/C Auto switch operation	On	Off	○	–	○
Switching to the outside air mode when the vehicle is parked	On	Off	–	–	○

### ■ Illumination (→P.306)

Function	Default setting	Customized setting	A	B	C
Time elapsed before the interior lights turn off	15 seconds	Off	○	–	○
		7.5 seconds			
		30 seconds			
Operation after the power switch is turned off	On	Off	–	–	○

Function	Default setting	Customized setting	A	B	C
Operation when the doors are unlocked	On	Off	-	-	O
Operation when you approach the vehicle with the electronic key on your person	On	Off	-	-	O
Footwell lighting *	On	Off	-	-	O

\*: If equipped

### ■ Vehicle customization

- When the speed linked door locking function and shift position linked door locking function are both on, the door lock operates as follows.
- If the vehicle is started with all the doors locked, the speed linked door locking function would not operate.
- If the vehicle is started with any door unlocked, the speed linked door locking function will operate.
- When shifting the shift lever to any position other than P, all the doors will be locked.
- When the smart entry & start system is off, the selecting door to unlock cannot be customized.
- When the doors remain closed after unlocking the doors and the automatic door lock function is activated, the signals will be generated in accordance with the Operation signal (buzzer) and the Operation signal (emergency flashers) settings.

## Items to initialize

The following items must be initialized for normal system operation after such cases as the 12-volt battery being reconnected, or maintenance being performed on the vehicle:

### List of the items to initialize

Item	When to initialize	Reference
Power back door*	<ul style="list-style-type: none"> <li>After reconnecting or changing the 12-volt battery</li> <li>After changing a fuse</li> </ul>	P.126
Power windows	<ul style="list-style-type: none"> <li>When functioning abnormally</li> </ul>	P.155
Moon roof*		P.158
Toyota parking assist monitor*	<ul style="list-style-type: none"> <li>After reconnecting or changing the 12-volt battery</li> <li>After changing a fuse</li> </ul>	Refer to "Multimedia Owner's Manual"
Panoramic view monitor*		

\*: If equipped

Index

What to do if... (Troubleshooting) .....444  
Alphabetical Index .....446

## What to do if... (Troubleshooting)

If you have a problem, check the following before contacting your Toyota dealer.

### The doors cannot be locked, unlocked, opened or closed



#### You lose your keys

- If you lose your mechanical keys, new genuine mechanical keys can be made by your Toyota dealer. (→P.405)
- If you lose your electronic keys, the risk of vehicle theft increases significantly. Contact your Toyota dealer immediately. (→P.405)



#### The doors cannot be locked or unlocked

- Is the key battery weak or depleted? (→P.363)
- Is the power switch in ON? When locking the doors, turn the power switch to OFF. (→P.179)
- Is the electronic key left inside the vehicle? When locking the doors, make sure that you have the electronic key on your person.
- The function may not operate properly due to the condition of the radio wave. (→P.131)



#### The rear door cannot be opened

- Is the child-protector lock set? The rear door cannot be opened from inside the vehicle when the lock is set. Open the rear door from outside and then unlock the child-protector lock. (→P.118)

### If you think something is wrong



#### The hybrid system does not start

- Did you press the power switch while firmly depressing the brake pedal? (→P.177)
- Is the shift lever in P? (→P.177)
- Is the electronic key anywhere detectable inside the vehicle? (→P.130)
- Is the electronic key battery weak or depleted? In this case, the hybrid system can be started in a temporary way. (→P.407)
- Is the 12-volt battery discharged? (→P.408)



#### The shift lever cannot be shifted from P even if you depress the brake pedal

- Is the power switch in ON? If you cannot release the shift

lever by depressing the brake pedal with the power switch in ON (→P.184)



**The windows do not open or close by operating the power window switches**

- Is the window lock switch pressed?  
The power window except for the one at the driver's seat cannot be operated if the window lock switch is pressed. (→P.157)



**The power switch is turned off automatically**

- The auto power off function will be operated if the vehicle is left in ACC or ON (the hybrid system is not operating) for a period of time. (→P.179)



**A warning buzzer sounds during driving**

- The seat belt reminder light is flashing

Are the driver and the passengers wearing the seat belts? (→P.391)

- The parking brake indicator is on  
Is the parking brake released? (→P.187)

Depending on the situation, other types of warning buzzer may also sound. (→P.385, 392)



**A warning buzzer sounds when leaving the vehicle**

- Is the message displayed on the multi-information display?  
Check the message on the multi-information display. (→P.392)



**A warning light turns on or a warning message is displayed**

- When a warning light turns on or a warning message is displayed, refer to P.385, 392.

**When a problem has occurred**



**If you have a flat tire**

- Stop the vehicle in a safe place and replace the flat tire with the spare tire. (→P.396)



**The vehicle becomes stuck**

- Try the procedure for when the vehicle becomes stuck in mud, dirt, or snow. (→P.416)

# Alphabetical Index

## A

<b>A/C</b> .....	<b>298</b>
Air conditioning filter.....	353
Automatic air conditioning system .....	298
Eco air conditioning mode.....	300
Front seat concentrated airflow mode (S-FLOW) .....	302
<b>ABS (Anti-lock Brake System)</b> ....	<b>281</b>
Function .....	281
Warning light .....	387
<b>ACA (Active Cornering Assist)</b> ....	<b>282</b>
<b>Active Cornering Assist (ACA)</b> ....	<b>282</b>
<b>Airbags</b> .....	<b>32</b>
Airbag operating conditions .....	34
Airbag precautions for your child ..	36
Airbag warning light .....	387
Correct driving posture.....	27
Curtain shield airbag operating conditions .....	34
Curtain shield airbag precautions ..	36
General airbag precautions.....	36
Locations of airbags.....	32
Modification and disposal of airbags .....	39
Side airbag operating conditions..	34
Side airbag precautions .....	36
Side and curtain shield airbags operating conditions.....	34
Side and curtain shield airbags precautions .....	36
SRS airbags.....	32
SRS warning light .....	387
<b>Air conditioning filter</b> .....	<b>353</b>
<b>Air conditioning system</b> .....	<b>298</b>
Air conditioning filter.....	353
Automatic air conditioning system .....	298
Eco air conditioning mode.....	300
Front seat concentrated airflow	

mode (S-FLOW).....302

## Alarm

Warning buzzer.....385

**Anchor fittings** .....

**Antenna (Smart entry & start system)**.....

**Anti-lock brake system (ABS)** .....

Function .....

Warning light .....

**Approach warning** .....

**Armrest**.....

**Assist grips** .....

**Audio system-linked display** .93, 102

**Automatic air conditioning system** .....

Air conditioning filter.....

Eco air conditioning mode.....

**Automatic headlight leveling system** .....

**Automatic High Beam** .....

**Automatic light control system**...193

**Auxiliary box** .....

**Average fuel economy** .....

**Average vehicle speed**.....

## B

**Back door** .....

Power back door .....

Wireless remote control .....

**Back-up lights**

Replacing light bulbs.....

Wattage.....

**Battery (12-volt battery)** .....

If the 12-volt battery is discharged .....

Preparing and checking before winter.....

Replacing .....

Warning light .....

**Battery (traction battery)**.....

**Blind Spot Monitor (BSM)** .....



Blind Spot Monitor function .....	251
<b>Bottle holders .....</b>	<b>310</b>
<b>Brake</b>	
Brake Hold .....	191
Parking brake .....	187
Regenerative braking .....	61
Warning light .....	385
<b>Brake assist .....</b>	<b>281</b>
<b>Brake Hold .....</b>	<b>191</b>
<b>Break-in tips .....</b>	<b>163</b>
<b>BSM (Blind Spot Monitor) .....</b>	<b>249</b>
Blind Spot Monitor function .....	251

## C

<b>Card holder .....</b>	<b>311</b>
<b>Care</b>	
Aluminum wheels .....	328
Exterior .....	328
Interior .....	332
Seat belts .....	332
<b>Cargo hooks .....</b>	<b>312</b>
<b>Chains .....</b>	<b>291</b>
<b>Child-protectors .....</b>	<b>118</b>
<b>Child restraint system .....</b>	<b>42</b>
Fixed with a seat belt .....	50
Fixed with an ISOFIX rigid anchor .....	52
Points to remember .....	42
Riding with children .....	41
Types of child restraint system installation method .....	49
Using a child restraint anchor fitting .....	53
<b>Child safety .....</b>	<b>41</b>
12-volt battery precautions .....	348, 411
Airbag precautions .....	36
Back door precautions .....	120
Child restraint system .....	42
How your child should wear the seat belt .....	30
Moon roof precautions .....	159
Power window lock switch .....	157
Power window precautions .....	156
Rear door child-protectors .....	118
Seat belt precautions .....	29
Seat heater precautions .....	304
<b>Cleaning .....</b>	<b>328, 332</b>
Aluminum wheels .....	328
Exterior .....	328
Interior .....	332
Radar sensor .....	205, 250
Seat belts .....	332
<b>Clock .....</b>	<b>83</b>
<b>Coat hooks .....</b>	<b>326</b>
<b>Condenser .....</b>	<b>346</b>
<b>Console box .....</b>	<b>309</b>
<b>Consumption screen .....</b>	<b>107</b>
<b>Convenience Services (Suggestion     function) .....</b>	<b>97, 106</b>
<b>Coolant</b>	
Checking .....	345
Preparing and checking before win- ter .....	290
Warning light .....	386
<b>Cooling system .....</b>	<b>345</b>
Hybrid system overheating .....	413
<b>Cruise control</b>	
Cruise control .....	246
Dynamic radar cruise control with full-speed range .....	234
<b>Cup holders .....</b>	<b>309</b>
<b>Current fuel economy .....</b>	<b>90, 102</b>
<b>Curtain shield airbags .....</b>	<b>32</b>
<b>Customizable features .....</b>	<b>429</b>

## D

<b>Daytime running light system .....</b>	<b>193</b>
Replacing light bulbs .....	367
<b>Deck board .....</b>	<b>312</b>
<b>Defogger</b>	
Outside rear view mirrors .....	300
Rear window .....	300
Windshield .....	299

**Differential** ..... 425

**Digital Rear-view Mirror** ..... 144

**Dimensions** ..... 420

**Display**

- BSM (Blind Spot Monitor) ..... 249
- Consumption screen ..... 107
- Cruise control ..... 246
- Drive information ..... 93, 102
- Driving information ..... 90, 102
- Dynamic radar cruise control with full-speed range ..... 234
- Energy monitor ..... 107
- LTA (Lane-Tracing Assist) ..... 226
- Multi-information display ..... 88, 98
- RCTA (Rear Cross Traffic Alert) function ..... 263
- Toyota parking assist-sensor ..... 253
- Warning messages ..... 392

**Do-it-yourself maintenance** ..... 337

**Door lock**

- Back door ..... 120
- Side doors ..... 115
- Smart entry & start system ..... 129
- Wireless remote control ..... 113

**Doors**

- Automatic door locking and unlocking system ..... 119
- Back door ..... 120
- Door glasses ..... 155
- Door lock ..... 115
- Open door warning buzzer ..... 118
- Outside rear view mirrors ..... 153
- Rear door child-protectors ..... 118
- Side doors ..... 115

**Double locking system** ..... 69

**Drive information** ..... 93, 102

**Driver's seat belt reminder light**.. 391

**Driver's seat position memory** .... 137

- Driving position memory ..... 137
- Memory recall function ..... 138

**Drive-Start Control (DSC)**

- Sudden start restraint control ..... 167

**Driving**

- Break-in tips ..... 163
- Correct posture ..... 27
- Driving mode select switch ..... 278
- Hybrid Electric Vehicle driving tips ..... 288
- Procedures ..... 162
- Winter drive tips ..... 290

**Driving information display** ..... 90, 99

**Driving mode select switch** ..... 278

**Driving position memory** ..... 137

- Memory recall function ..... 138

**Driving support system information display** ..... 92, 102

**DSC (Drive-Start Control)**

- Sudden start restraint control ..... 167

**Dynamic radar cruise control with full-speed range**

- Function ..... 234
- Warning message ..... 392

**E**

**ECB (Electronically Controlled Brake System)** ..... 281

**Eco drive mode** ..... 278

**EDR (Event data recorder)** ..... 8

**E-Four (Electronic On-Demand AWD system)** ..... 282

**Elapsed time** ..... 93, 102

**Electric motor**

- Location ..... 60
- Specification ..... 421

**Electric Power Steering (EPS)**

- Function ..... 282
- Warning light ..... 387

**Electronic key**

- Battery-saving function ..... 131
- If the electronic key does not operate properly ..... 406
- Replacing the battery ..... 363

**Emergency, in case of**

- If a warning buzzer sounds ..... 385
- If a warning light turns on ..... 385
- If a warning message is displayed  
..... 392
- If the 12-volt battery is discharged  
..... 408
- If the electronic key does not operate  
properly ..... 406
- If the fuel filler door cannot be  
opened ..... 406
- If the hybrid system will not start 404
- If the vehicle is submerged or water  
on the road is rising ..... 377
- If you have a flat tire ..... 396
- If you lose your keys ..... 405
- If you think something is wrong.. 383
- If your vehicle becomes stuck.... 416
- If your vehicle has to be stopped in  
an emergency ..... 376
- If your vehicle needs to be towed  
..... 379
- If your vehicle overheats ..... 413

**Emergency brake signal ..... 282****Emergency flashers ..... 376****Energy monitor ..... 107****Engine**

- Compartment ..... 342
- Hood ..... 339
- Identification number ..... 421
- Tachometer ..... 83

**Engine coolant**

- Capacity ..... 424
- Checking ..... 345
- Preparing and checking before win-  
ter ..... 290
- Warning light ..... 386

**Engine coolant temperature .... 78, 83****Engine oil**

- Capacity ..... 422
- Checking ..... 343

- Preparing and checking before win-  
ter ..... 290

Warning light ..... 386

**EPS (Electric Power Steering)**

Function ..... 282

Warning light ..... 387

**EV drive mode ..... 181****Event data recorder (EDR) ..... 8****EV indicator ..... 61****Exhaust gas precautions ..... 39****F****Flat tire ..... 396****Floor mats ..... 26****Fluid**

Brake ..... 425

Hybrid transmission ..... 424

Rear differential ..... 425

Washer ..... 346

**Fog lights**

Replacing light bulbs ..... 367

Switch ..... 198

**Footwell lights ..... 306****Front passenger's seat belt reminder  
light ..... 391****Front position lights**

Light switch ..... 193

Replacing light bulbs ..... 367

**Front seats ..... 134**

Adjustment ..... 134

Cleaning ..... 332

Correct driving posture ..... 27

Driving position memory ..... 137

Head restraints ..... 140

Memory recall function ..... 138

Seat heaters ..... 304

Seat position memory ..... 137

Seat ventilators ..... 304

**Front turn signal lights**

Replacing light bulbs ..... 367

Turn signal lever ..... 186

**Fuel**

Capacity .....	421
Fuel gauge .....	78, 83
Gas station information .....	460
Information .....	428
Refueling .....	203
Type .....	421
Warning light .....	390

**Fuel filler door ..... 204**

If the fuel filler door cannot be opened.....	406
Refueling .....	203

**Fuel gauge ..... 78, 83****Fuses ..... 365****G****Gas station information ..... 460****Gauges ..... 78, 83****Glove box ..... 309****H****Headlights ..... 193**

Automatic headlight leveling .....	194
Automatic High Beam system.....	195
Light switch .....	193
Replacing light bulbs.....	367

**Head restraints ..... 140****Heaters**

Automatic air conditioning system .....	298
Outside rear view mirrors.....	300
Seat heaters.....	304

**High mounted stoplight**

Replacing light bulbs.....	367
----------------------------	-----

**Hill-start assist control..... 282****Hood ..... 339****Hooks**

Cargo hooks.....	312
Coat hooks.....	326
Retaining hooks (floor mat).....	26

**Horn ..... 142****Hybrid battery (traction battery)**

Location.....	63
Specification.....	422

**Hybrid battery air vent..... 66****Hybrid system ..... 60**

Emergency shut off system.....	66
Energy monitor/consumption screen .....	107
EV drive mode.....	181
High voltage components.....	63
How to start the hybrid system... ..	177
Hybrid Electric Vehicle driving tips .....	288
Hybrid System Indicator .....	78
Hybrid system precautions.....	63
If the hybrid system will not start.....	404
If your vehicle has to be stopped in an emergency .....	376
Ignition switch (power switch) ....	177
Overheating.....	413
Power (ignition) switch .....	177
Regenerative braking.....	61
Starting the hybrid system.....	177

**Hybrid System Indicator ..... 78, 86****Hybrid transmission ..... 183**

S mode.....	185
-------------	-----

**I****Identification number**

Engine .....	421
Vehicle .....	420

**Ignition switch (power switch) .... 177**

Auto power off function .....	179
Changing the power switch modes .....	179
Starting the hybrid system.....	177

**Illuminated entry system..... 306****Immobilizer system ..... 68****Indicators..... 72****Initialization**

Items to initialize .....	442
Moon roof .....	158
Parking Support Brake .....	272
Power back door .....	126
Power windows .....	155
<b>Inside rear view mirror .....</b>	<b>143, 144</b>
<b>Installing a child restraint system to a front passenger seat .....</b>	<b>43</b>
<b>Interior lights .....</b>	<b>306</b>
Switch .....	307

## J

### Jack

Positioning a floor jack .....	340
Vehicle-equipped jack .....	397

### Jack handle .....

**397**

### Jam protection function

Moon roof .....	158
Power back door .....	125
Power windows .....	155

## K

### Keyless entry

Smart entry & start system .....	129
Wireless remote control .....	113

### Keys .....

**112**

Battery-saving function .....	131
Electronic key .....	112
If the electronic key does not operate properly .....	406
If you lose your keys .....	405
Key number plate .....	112
Keyless entry .....	113, 129
Mechanical key .....	114
Power switch .....	177
Replacing the battery .....	363
Warning buzzer .....	130
Wireless remote control key .....	113

### Knee airbags .....

**32**

## L

### Lane Tracing Assist (LTA) .....

**220**

Operation .....	220
Warning messages .....	230

### Language (multi-information display) .....

**96, 103, 430**

### Lever

Auxiliary catch lever .....	339
Hood lock release lever .....	339
Shift lever .....	183
Turn signal lever .....	186
Wiper lever .....	199, 201

### License plate lights

Light switch .....	193
Replacing light bulbs .....	367

### Light bulbs

Replacing .....	367
-----------------	-----

### Lights

Automatic High Beam system .....	195
Fog light switch .....	198
Front interior lights .....	307
Headlight switch .....	193
Illuminated entry system .....	306
Interior light list .....	306
Interior lights .....	307
Personal lights .....	307
Rear interior light .....	307
Replacing light bulbs .....	367
Turn signal lever .....	186
Vanity lights .....	317
Wattage .....	427

### LTA (Lane Tracing Assist) .....

**220**

Operation .....	220
Warning messages .....	230

### Luggage compartment light 122, 124

### Luggage cover .....

**315**

## M

### Maintenance

Do-it-yourself maintenance .....	337
----------------------------------	-----

Maintenance data ..... 420  
 Maintenance requirements ..... 335  
**Malfunction indicator lamp..... 386**  
**Menu icons..... 90**  
**Meter**  
 Clock ..... 83  
 Hybrid System Indicator ..... 86  
 Indicators ..... 72  
 Meter control switches ..... 89, 99  
 Meters ..... 78, 83  
 Multi-information display ..... 82, 88  
 Settings ..... 94, 103, 429  
 Units ..... 96, 430  
 Warning lights ..... 385  
 Warning messages ..... 392  
**Meter control switches..... 89, 99**  
**Mirrors**  
 Digital Rear-view Mirror ..... 144  
 Inside rear view mirror ..... 143  
 Outside rear view mirror defoggers  
 ..... 300  
 Outside rear view mirrors ..... 153  
 Vanity mirrors ..... 317  
**Moon roof**  
 Door lock linked moon roof operation  
 ..... 158  
 Jam protection function ..... 158  
 Operation ..... 158  
 Warning message ..... 159  
**Multi-information display..... 88, 98**  
 Audio system-linked display . 93, 102  
 Changing the display ..... 89, 99  
 Convenience Services (Suggestion  
 function) ..... 97, 106  
 Cruise control ..... 246  
 Display contents ..... 88, 98  
 Driving information display ..... 90, 99  
 Driving support system information  
 display ..... 92, 102  
 Dynamic radar cruise control with  
 full-speed range ..... 234

Energy monitor ..... 107  
 Hybrid System Indicator ..... 81  
 Language ..... 96, 430  
 LTA (Lane-Tracing Assist) ..... 226  
 Menu icons ..... 90  
 Meter control switches ..... 89, 99  
 Navigation system-linked display 93,  
 102  
 PCS (Pre-Collision System) ..... 210  
 Pop-up display ..... 96, 430  
 Settings ..... 94, 103, 429  
 Suggestion function ..... 106  
 Units ..... 96, 430  
 Vehicle information display ..... 93  
 Warning message display ..... 97  
 Warning messages ..... 392

**N**

**Navigation system-linked display 93,  
 102**  
**Normal mode..... 278**

**O**

**Odometer ..... 78, 88**  
**Odometer and trip meter display**  
 “ODO TRIP” switch ..... 82, 88  
 Display items ..... 88  
**“ODO TRIP” switch..... 82, 88**  
**Oil**  
 Engine oil ..... 422  
**Opener**  
 Back door ..... 122, 124  
 Fuel filler door ..... 204  
 Hood ..... 339  
**Outer foot lights**  
 Replacing light bulbs ..... 367  
 Wattage ..... 427  
**Outside rear view mirrors ..... 153**  
 Adjusting and folding ..... 153  
 BSM (Blind Spot Monitor) ..... 249

Outside rear view mirror defoggers .....	300
RCTA (Rear Cross Traffic Alert) function .....	263
<b>Outside temperature .....</b>	<b>81, 83</b>
<b>Outside temperature display .....</b>	<b>78</b>
<b>Overheating .....</b>	<b>413</b>

## P

<b>Parking assist sensors (Toyota park- ing assist-sensor) .....</b>	<b>253</b>
<b>Parking brake</b>	
Operation .....	187
Parking brake engaged warning buzzer .....	190
Warning light .....	390
Warning message .....	189
<b>Parking Support Brake (PKSB) ...</b>	<b>268</b>
Parking Support Brake function (rear-crossing vehicles) .....	276
Parking Support Brake function (static objects) .....	273
Warning light .....	389
<b>PCS (Pre-Collision System)</b>	
Enabling/disabling the pre-collision system .....	213
Function .....	210
Warning light .....	388
Warning message .....	208, 394
<b>Personal lights .....</b>	<b>307</b>
Switch .....	307
<b>PKSA (Parking Support Alert)</b>	
RCTA (Rear Cross Traffic Alert)	263
<b>PKSB (Parking Support Brake) ...</b>	<b>268</b>
Parking Support Brake function (rear-crossing vehicles) .....	276
Parking Support Brake function (static objects) .....	273
Warning light .....	389
<b>Power back door switch .....</b>	<b>123, 124</b>
<b>Power outlet .....</b>	<b>317</b>

<b>Power steering (Electric Power Steering system) .....</b>	<b>282</b>
Warning light .....	387
<b>Power switch .....</b>	<b>177</b>
Auto power off function .....	179
Changing the power switch modes .....	179
Starting the hybrid system.....	177
<b>Power windows</b>	
Door lock linked window operation .....	156
Jam protection function .....	155
Operation .....	155
Window lock switch .....	157
<b>Pre-Collision System (PCS)</b>	
Enabling/disabling the pre-collision system.....	213
Function .....	210
Warning light .....	388
Warning message .....	208, 394

## R

<b>Radar cruise control</b>	
Dynamic radar cruise control with full-speed range .....	234
<b>Radiator .....</b>	<b>346</b>
<b>RCTA (Rear Cross Traffic Alert)</b>	
function .....	264
<b>RCTA .....</b>	<b>263</b>
RCTA Function.....	264
<b>RCTA function.....</b>	<b>264</b>
<b>Rear Cross Traffic Alert (RCTA) ..</b>	<b>263</b>
<b>Rear passengers' seat belt reminder light .....</b>	<b>391</b>
<b>Rear seat</b>	
Folding down the rear seatbacks	136
Head restraints.....	140
<b>Rear turn signal lights</b>	
Replacing light bulbs .....	367
Turn signal lever.....	186
Wattage.....	427

**Rear view mirror**  
     Digital Rear-view Mirror ..... 144  
     Inside rear view mirror ..... 143  
     Outside rear view mirrors ..... 153  
**Rear window defogger** ..... **300**  
**Rear window wiper** ..... **201**  
**Refueling** ..... **203**  
     Capacity ..... 421  
     Fuel types ..... 421  
     If the fuel filler door cannot be  
         opened ..... 406  
     Opening the fuel tank cap ..... 203  
**Regenerative braking** ..... **61**  
**Replacing**  
     Electronic key battery ..... 363  
     Fuses ..... 365  
     Light bulbs ..... 367  
     Wiper insert ..... 359  
     Wireless remote control battery ..... 363  
**Road accident cautions** ..... **64**  
**Road Sign Assist** ..... **231**  
**RSA (Road Sign Assist)** ..... **231**

**S**

**Seat belt reminder light** ..... **391**  
**Seat belts** ..... **29**  
     Adjusting the seat belt shoulder  
         anchor height ..... 31  
     Child restraint system installation 50  
     Cleaning and maintaining the seat  
         belt ..... 332  
     Emergency Locking Retractor ..... 31  
     How to wear your seat belt ..... 30  
     How your child should wear the seat  
         belt ..... 30  
     Pregnant women, proper seat belt  
         use ..... 29  
     Reminder light and buzzer ..... 391  
     Seat belt pretensioners ..... 31  
     SRS warning light ..... 387  
**Seat heaters** ..... **304**

**Seat position memory** ..... **137**  
**Seats**  
     Adjustment precautions ..... 134, 135  
     Adjustment ..... 134, 135  
     Child restraint system installation. 42  
     Cleaning ..... 332  
     Driving position memory ..... 137  
     Folding down the rear seatbacks 136  
     Head restraint ..... 140  
     Properly sitting in the seat ..... 27  
     Seat heaters ..... 304  
     Seat position memory ..... 137  
     Seat ventilators ..... 304  
**Seat ventilators** ..... **304**  
**Secondary Collision Brake** ..... **282**  
**Sensor**  
     Automatic headlight system ..... 193  
     Automatic High Beam system ..... 195  
     BSM (Blind Spot Monitor) ..... 250  
     Digital Rear-view Mirror ..... 148  
     Inside rear view mirror ..... 144  
     LTA (Lane Tracing Assist) ..... 220  
     Parking Support Brake function  
         (rear-crossing vehicles) ..... 250  
     Rain-sensing windshield wipers ..... 200  
     RCTA (Rear Cross Traffic Alert) ..... 250  
     Toyota parking assist-sensor ..... 253  
     Toyota Safety Sense ..... 205  
**Service plug** ..... **63**  
**Service reminder indicators** ..... **72**  
**Shift lever** ..... **183**  
     If the shift lever cannot be shifted  
         from P ..... 184  
**Shift lock system** ..... **184**  
**Side airbags** ..... **32**  
**Side auxiliary box** ..... **314**  
**Side doors** ..... **115**  
**Side mirrors** ..... **153**  
     Adjustment ..... 153  
     BSM (Blind Spot Monitor) ..... 249  
     Folding ..... 154



- Heaters ..... 300
- RCTA (Rear Cross Traffic Alert)
  - function ..... 263
- Side turn signal lights**
- Replacing light bulbs ..... 367
- Turn signal lever ..... 186
- Side windows ..... 155**
- Smart entry & start system ..... 129**
- Antenna location ..... 129
- Entry functions ..... 115, 121
- Starting the hybrid system ..... 177
- Warning message ..... 392
- Snow tires ..... 290**
- “SOS” button ..... 56**
- Spare tire**
- Storage location ..... 397
- Specifications ..... 420**
- Speedometer ..... 78, 83**
- Sport mode ..... 278**
- Steering wheel**
- Adjustment ..... 142
- Meter control switches ..... 89, 99
- Stop lights**
- Replacing light bulbs ..... 367
- Storage feature ..... 308**
- Storage precautions ..... 309**
- Stuck**
- If the vehicle becomes stuck ..... 416
- Suggestion function ..... 106**
- Sunglass holder ..... 310**
- Sunshade ..... 158**
- Sun visors ..... 317**
- Switches**
- “ODO TRIP” switch ..... 82, 88
- “SOS” button ..... 56
- Automatic High Beam switch ..... 195
- Brake hold switch ..... 191
- BSM (Blind Spot Monitor) switch ..... 250
- Cruise control switch ..... 246
- Digital Rear-view Mirror control
  - switches ..... 144
- Door lock switch ..... 118
- Driving mode select switch ..... 278
- Driving position memory switches
  - ..... 137
- Dynamic radar cruise control with
  - full-speed range ..... 234
- Emergency flashers switch ..... 376
- EV drive mode switch ..... 181
- Fog light switch ..... 198
- Ignition switch ..... 177
- Light switch ..... 193
- LTA switch ..... 225
- Meter control switches ..... 89, 99
- Moon roof switches ..... 158
- Outside rear view mirror switches
  - ..... 153
- Parking brake switch ..... 187
- PKSB (Parking Support Brake) .. 270
- Power back door switch ..... 123, 124
- Power door lock switch ..... 118
- Power switch ..... 177
- Power window switch ..... 155
- RCTA switch ..... 263
- Rear window and outside rear view
  - mirror defoggers switch ..... 300
- Rear window wiper and washer
  - switch ..... 201
- Seat heaters ..... 304
- Seat ventilators ..... 304
- Toyota parking assist-sensor ..... 254
- Vehicle-to-vehicle distance switch
  - ..... 234
- VSC OFF switch ..... 282
- Window lock switch ..... 157
- Windshield defogger switch ..... 299
- Windshield wipers and washer
  - switch ..... 199
- Wireless charger switch ..... 319

## T

**Tachometer ..... 83**

- Tail lights**  
 Light switch ..... 193  
 Replacing light bulbs ..... 367
- Theft deterrent system**  
 Double locking system ..... 69  
 Immobilizer system ..... 68
- Tire inflation pressure ..... 426**
- Tires ..... 349**  
 Chains ..... 291  
 Checking ..... 349  
 If you have a flat tire ..... 396  
 Inflation pressure ..... 351  
 Replacing ..... 396  
 Rotating tires ..... 350  
 Snow tires ..... 290  
 Spare tire ..... 396
- Tools ..... 397**
- Towing**  
 Emergency towing ..... 379  
 Towing eyelet ..... 381, 397  
 Trailer sway control ..... 282  
 Trailer towing ..... 169
- Toyota Connected Services ..... 56**
- Toyota parking assist-sensor ..... 253**  
 Function ..... 253  
 Warning message ..... 255
- Toyota Safety Sense ..... 205**  
 Automatic High Beam ..... 195  
 Dynamic radar cruise control with  
 full-speed range ..... 234  
 LTA (Lane Tracing Assist) ..... 220  
 PCS (Pre-Collision System) ..... 210  
 RSA (Road Sign Assist) ..... 231
- Traction battery (Hybrid battery) ... 63**  
 Hybrid battery (traction battery) air  
 intake and discharge vents ..... 66  
 Location ..... 63  
 Specification ..... 422  
 Warning messages ..... 66
- Traction control (TRC) ..... 282**
- Traction motor (electric motor) ..... 60**
- Trailer sway control ..... 282**
- Trailer towing ..... 169**
- Trail Mode ..... 280**
- Transmission**  
 Driving mode select switch ..... 278  
 Hybrid transmission ..... 183  
 S mode ..... 185
- TRC (Traction Control) ..... 282**
- Trip meters ..... 78, 88**
- Turn signal lights**  
 Replacing light bulbs ..... 367  
 Turn signal lever ..... 186  
 Wattage ..... 427

## U

- USB charging ports ..... 318**
- Utility vehicle precautions ..... 293**

## V

- Vanity lights**  
 Vanity lights ..... 317
- Vanity mirrors ..... 317**
- Vehicle data recordings ..... 7**
- Vehicle identification number ..... 420**
- Vehicle Stability Control (VSC) .... 281**
- VSC (Vehicle Stability Control) .... 281**

## W

- Warning buzzers**  
 Approach warning ..... 241  
 Brake hold ..... 390  
 Brake Override System ..... 390  
 Brake system ..... 385  
 Downshifting ..... 185  
 Drive-Start Control ..... 390  
 Electric power steering ..... 387  
 High coolant temperature ..... 386  
 Low engine oil pressure ..... 386  
 LTA (Lane Tracing Assist) ..... 220

- LTA indicator ..... 388
- Open door ..... 118
- Open hood ..... 118
- Open window ..... 156
- PKSB OFF indicator ..... 389
- Pre-collision warning ..... 210
- RCTA OFF indicator ..... 389
- Seat belt reminder ..... 391
- Toyota parking assist-sensor OFF indicator ..... 388
- Vehicle sway warning ..... 224
- Warning lights**
- ABS ..... 387
- Brake hold operated indicator .... 390
- Brake Override System ..... 390
- Brake system ..... 385
- Charging system ..... 385
- Drive-Start Control ..... 390
- Electric power steering ..... 387
- High coolant temperature ..... 386
- Inappropriate pedal operation .... 390
- Low engine oil pressure ..... 386
- Low fuel level ..... 390
- LTA indicator ..... 388
- Malfunction indicator lamp ..... 386
- Parking brake indicator ..... 390
- PCS warning light ..... 388
- PKSB OFF indicator ..... 389
- RCTA OFF indicator ..... 389
- Seat belt reminder light ..... 391
- Slip indicator ..... 389
- SRS ..... 387
- Toyota parking assist-sensor OFF indicator (warning buzzer) ..... 388
- Warning messages** ..... **392**
- Washer**
- Checking ..... 346
- Low washer fluid warning message ..... 346, 392
- Preparing and checking before winter ..... 290
- Switch ..... 199, 201
- Washing and waxing** ..... **328**
- Wheels** ..... **352**
- Replacing wheels ..... 352
- Window glasses**
- Power windows ..... 155
- Window lock switch** ..... **157**
- Windows**
- Power windows ..... 155
- Rear window defogger ..... 300
- Washer ..... 199, 201
- Windshield defoggers** ..... **299**
- Windshield wipers**
- Intermittent windshield wipers .... 199
- Position ..... 199
- Rain-sensing windshield wipers . 199
- Replacing the wiper insert ..... 359
- Winter driving tips** ..... **290**
- Wiper insert** ..... **359**
- Wireless charger** ..... **319**
- Wireless remote control** ..... **113**
- Battery-saving function ..... 131
- Locking/Unlocking ..... 113
- Replacing the battery ..... 363

---

**For information regarding the equipment listed below, refer to the “Multimedia Owner’s Manual”.**

- Navigation system
- Audio system
- Rear view monitor system
- Toyota parking assist monitor
- Panoramic view monitor

**Certifications**

**Millimeter wave radar sensor**



**Wireless charger**



**Tire pressure warning system**

Approval Number: T-789/19



## GAS STATION INFORMATION

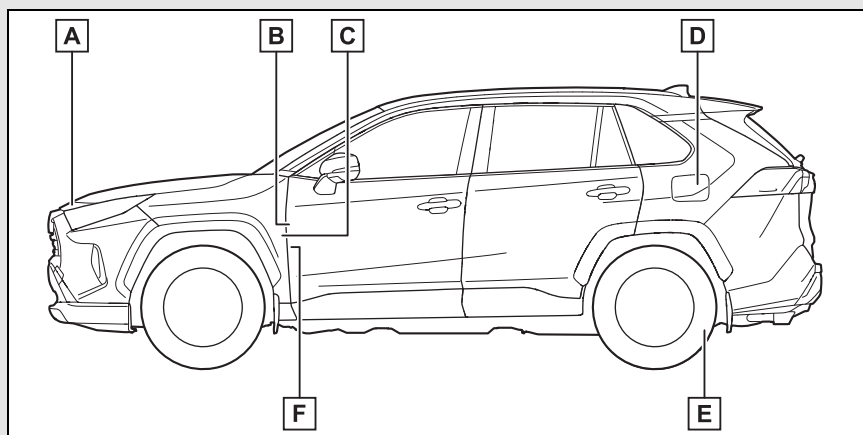

- A** Auxiliary catch lever (→P.339)
- B** Power back door switch\* (→P.123)
- C** Fuel filler door opener switch (→P.204)
- D** Fuel filler door (→P.204)
- E** Tire inflation pressure (→P.426)
- F** Hood lock release lever (→P.339)

\*: Vehicles with power back door

Fuel tank capacity (Reference)	55 L (14.5 gal., 12.1 Imp.gal.)	
Fuel type	Unleaded gasoline only	P.421
Cold tire inflation pressure		P.426
Engine oil capacity (Drain and refill — reference)		P.422
Engine oil type		P.422



