



Owner's Manual

For your safety and comfort, read carefully and keep in the vehicle.

HILUX



©2020 TOYOTA MOTOR CORPORATION

All rights reserved. This material may not be reproduced or copied, in whole or in part, without the written permission of Toyota Motor Corporation.

Pictorial index

Search by illustration

1

For safety and security

Make sure to read through them

2

Instrument cluster

How to read the gauges and meters, the variety of warning lights and indicators, etc.

3

Operation of each component

Opening and closing the doors and windows, adjustment before driving, etc.

4

Driving

Operations and advice which are necessary for driving

5

Interior features

Usage of the interior features, etc.

6

Maintenance and care

Caring for your vehicle and maintenance procedures

7

When trouble arises

What to do in case of malfunction or emergency

8

Vehicle specifications

Vehicle specifications, etc.

Index

Search by symptom

Search alphabetically

For your information	8
Reading this manual.....	12
How to search	13
Pictorial index	14

1 For safety and security

1-1. For safe use	
Before driving.....	26
For safe driving	28
Seat belts	30
SRS airbags.....	35
Exhaust gas precautions	45
1-2. Child safety	
Front passenger occupant classification system	46
Riding with children.....	51
Child restraint systems	52
1-3. Theft deterrent system	
Engine immobilizer system	77
Alarm	79

2 Instrument cluster

2. Instrument cluster	
Warning lights and indicators.....	82
Gauges and meters.....	89
Multi-information display	92
Fuel consumption information	101

3 Operation of each component

- 3-1. Key information**
 Keys 106
- 3-2. Opening, closing and locking the doors**
 Side doors 111
 Access panels (smart-cab models only) 116
 Tailgate 117
 Smart entry & start system 120
- 3-3. Adjusting the seats**
 Front seats 127
 Rear seats 129
 Head restraints 132
- 3-4. Adjusting the steering wheel and mirrors**
 Steering wheel 135
 Inside rear view mirror 137
 Outside rear view mirrors 139
- 3-5. Opening and closing the windows**
 Power windows 142
 Quarter windows (smart-cab models) 146

4 Driving

- 4-1. Before driving**
 Driving the vehicle 148
 Cargo and luggage 161
 Trailer towing 162
- 4-2. Driving procedures**
 Engine (ignition) switch (vehicles without smart entry & start system) 173
 Engine (ignition) switch (vehicles with smart entry & start system) 176
 Automatic transmission 184
 Manual transmission 191
 Turn signal lever 198
 Parking brake 199
- 4-3. Operating the lights and wipers**
 Headlight switch 200
 Fog light switch 204
 Windshield wipers and washer 205
- 4-4. Refueling**
 Opening the fuel tank cap 208

1

2

3

4

5

6

7

8

4-5. Using the driving support systems

Toyota Safety Sense	213
PCS (Pre-Collision System)	220
LDA (Lane Departure Alert With Yaw Assist Function).....	231
RSA (Road Sign Assist).....	242
Dynamic radar cruise control	246
Toyota parking assist-sensor	262
Four-wheel drive system.....	270
Rear differential lock system	280
Driving assist systems	284
Downhill assist control system	291
AUTO LSD.....	294
DPF (Diesel Particulate Filter) system	296

4-6. Driving tips

Winter driving tips	301
---------------------------	-----

5 Interior features

5-1. Using the air conditioning system and defogger

Manual air conditioning system.....	306
Automatic air conditioning system.....	311
Seat heaters.....	319

5-2. Using the interior lights

Interior lights list	320
• Personal/interior light main switch	321
• Personal/interior lights	321
• Interior light	321

5-3. Using the storage features

List of storage features.....	323
• Glove box.....	324
• Console box	324
• Cup holders	325
• Bottle holders	326
• Auxiliary boxes.....	327

Luggage compartment features	330
------------------------------------	-----

5-4. Using the other interior features

Other interior features	331
• Sun visors	331
• Vanity mirror	331
• Clock.....	332
• Power outlets	333
• Grocery bag hooks	335
• Coat hooks.....	335
• Armrest	336

6 Maintenance and care

- 6-1. Maintenance and care**
- Cleaning and protecting the vehicle exterior338
 - Cleaning and protecting the vehicle interior342
- 6-2. Maintenance**
- Maintenance requirements.....345
- 6-3. Do-it-yourself maintenance**
- Do-it-yourself service precautions347
 - Hood349
 - Engine compartment.....351
 - Tires364
 - Tire inflation pressure367
 - Wheels369
 - Air conditioning filter371
 - Wireless remote control/ electronic key battery.....373
 - Checking and replacing fuses376
 - Light bulbs381

7 When trouble arises

- 7-1. Essential information**
- Emergency flashers410
 - If your vehicle has to be stopped in an emergency411

7-2. Steps to take in an emergency

- If your vehicle needs to be towed 413
- If you think something is wrong 419
- Fuel pump shut off system (gasoline engine only) 420
- If a warning light turns on or a warning buzzer sounds 421
- If a warning message is displayed 426
- If you have a flat tire 431
- If the engine will not start 448
- If the electronic key does not operate properly (vehicles with smart entry & start system) 450
- If the vehicle battery is discharged 454
- If your vehicle overheats ... 459
- If you run out of fuel and the engine stalls (diesel engine only) 462
- If the vehicle becomes stuck..... 463

1

2

3

4

5

6

7

8

8 Vehicle specifications

8-1. Specifications

Maintenance data (fuel, oil level, etc.).....	466
Fuel information	481

8-2. Customization

Customizable features	483
-----------------------------	-----

Index

What to do if... (Troubleshooting)	490
Alphabetical index	494

Refer to the “Navigation and Multimedia System Owner’s Manual” or “Multimedia Owner’s Manual” for information regarding the equipment listed below.

- Navigation system
- Audio system
- Rear view monitor system



For your information

Main Owner's Manual

Please note that this manual applies to all models and all equipment, including options. Therefore, you may find some explanations for equipment not installed on your vehicle.

All specifications provided in this manual are current at the time of printing. However, because of the Toyota policy of continual product improvement, we reserve the right to make changes at any time without notice.

Depending on specifications, the vehicle shown in the illustrations may differ from your vehicle in terms of equipment.

Accessories, spare parts and modification of your Toyota

A wide variety of non-genuine spare parts and accessories for Toyota vehicles are currently available in the market. Using these spare parts and accessories which are not genuine Toyota products may adversely affect the safety of your vehicle, even though these parts may be approved by certain authorities in your country. Toyota Motor Corporation therefore cannot accept any liability or guarantee spare parts and accessories which are not genuine Toyota products, nor for replacement or installation involving such parts.

This vehicle should not be modified with non-genuine Toyota products. Modification with non-genuine Toyota products could affect its performance, safety or durability, and may even violate governmental regulations. In addition, damage or performance problems resulting from the modification may not be covered under warranty.

Installation of an RF-transmitter system

The installation of an RF-transmitter system in your vehicle could affect electronic systems such as:

- Multiport fuel injection system/sequential multiport fuel injection system
- Toyota Safety Sense
- Anti-lock brake system
- SRS airbag system
- Seat belt pretensioner system

Be sure to check with your Toyota dealer for precautionary measures or special instructions regarding installation of an RF-transmitter system.

Further information regarding frequency bands, power levels, antenna positions and installation provisions for the installation of RF-transmitters, is available on request at your Toyota dealer.

Vehicle data recording

The vehicle is equipped with sophisticated computers that will record certain data, such as:

- Engine speed/Electric motor speed (traction motor speed)
- Accelerator status
- Brake status
- Vehicle speed
- Operation status of the driving assist systems
- Images from the cameras

Your vehicle is equipped with cameras. Contact your Toyota dealer for the location of recording cameras.

The recorded data varies according to the vehicle grade level and options with which it is equipped.

These computers do not record conversations or sounds, and only record images outside of the vehicle in certain situations.

● Data usage

Toyota may use the data recorded in this computer to diagnose malfunctions, conduct research and development, and improve quality.

Toyota will not disclose the recorded data to a third party except:

- With the consent of the vehicle owner or with the consent of the lessee if the vehicle is leased
- In response to an official request by the police, a court of law or a government agency
- For use by Toyota in a lawsuit
- For research purposes where the data is not tied to a specific vehicle or vehicle owner

● Recorded image information can be erased by your Toyota dealer.

The image recording function can be disabled. However, if the function is disabled, data from when the system operates will not be available.

Event data recorder

This vehicle is equipped with an event data recorder (EDR). The main purpose of an EDR is to record, in certain crash or near crash-like situations, such as an airbag deployment or hitting a road obstacle, data that will assist in understanding how a vehicle's systems performed. The EDR is designed to record data related to vehicle dynamics and safety systems for a short period of time, typically 30 seconds or less. However, data may not be recorded depending on the severity and type of a crash.

The EDR in this vehicle is designed to record such data as:

- How various systems in your vehicle were operating;
- How far (if at all) the driver was depressing the accelerator and/or brake pedal; and,
- How fast the vehicle was traveling.

These data can help provide a better understanding of the circumstances in which crashes and injuries occur.

NOTE: EDR data are recorded by your vehicle only if a non-trivial crash situation occurs; no data are recorded by the EDR under normal driving conditions and no personal data (e.g., name, gender, age, and crash location) are recorded. However, other parties, such as law enforcement, could combine the EDR data with the type of personally identifying data routinely acquired during a crash investigation.

To read data recorded by an EDR, special equipment is required, and access to the vehicle or the EDR is needed. In addition to the vehicle manufacturer, other parties, such as law enforcement, that have the special equipment, can read the information if they have access to the vehicle or the EDR.

● Disclosure of the EDR data

Toyota will not disclose the data recorded in an EDR to a third party except when:

- An agreement from the vehicle's owner (or the lessee for a leased vehicle) is obtained
- In response to an official request by the police, a court of law or a government agency
- For use by Toyota in a lawsuit

However, if necessary, Toyota may:

- Use the data for research on vehicle safety performance
- Disclose the data to a third party for research purposes without disclosing information about the specific vehicle or vehicle owner

Scraping of your Toyota

The SRS airbag and seat belt pretensioner devices in your Toyota contain explosive chemicals. If the vehicle is scrapped with the airbags and seat belt pretensioners left as they are, this may cause an accident such as fire. Be sure to have the systems of the SRS airbag and seat belt pretensioner removed and disposed of by a qualified service shop or by your Toyota dealer before you scrap your vehicle.

WARNING

■ General precautions while driving

Driving under the influence: Never drive your vehicle when under the influence of alcohol or drugs that have impaired your ability to operate your vehicle. Alcohol and certain drugs delay reaction time, impair judgment and reduce coordination, which could lead to an accident that could result in death or serious injury.

Defensive driving: Always drive defensively. Anticipate mistakes that other drivers or pedestrians might make and be ready to avoid accidents.

Driver distraction: Always give your full attention to driving. Anything that distracts the driver, such as adjusting controls, talking on a cellular phone or reading can result in a collision with resulting death or serious injury to you, your occupants or others.

■ General precaution regarding children's safety

Never leave children unattended in the vehicle, and never allow children to have or use the key.

Children may be able to start the vehicle or shift the vehicle into neutral. There is also a danger that children may injure themselves by playing with the windows or other features of the vehicle. In addition, heat build-up or extremely cold temperatures inside the vehicle can be fatal to children.

Reading this manual



WARNING:

Explains something that, if not obeyed, could cause death or serious injury to people.



NOTICE:

Explains something that, if not obeyed, could cause damage to or a malfunction in the vehicle or its equipment.



1 2 3... Indicates operating or working procedures. Follow the steps in numerical order.



Indicates the action (pushing, turning, etc.) used to operate switches and other devices.

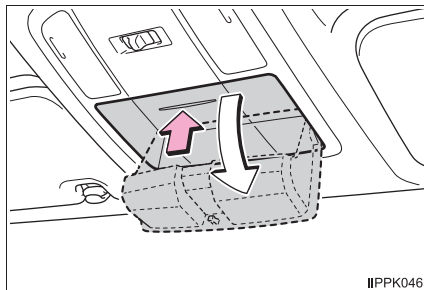

Indicates the outcome of an operation (e.g. a lid opens).



Indicates the component or position being explained.



Means “Do not”, “Do not do this”, or “Do not let this happen”.

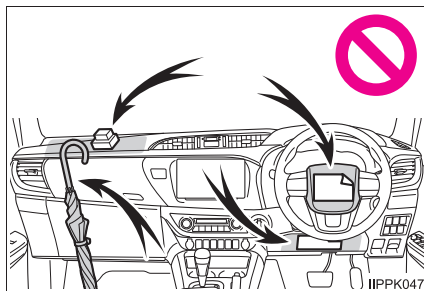

How to search

■ Searching by name

- Alphabetical index P. 494

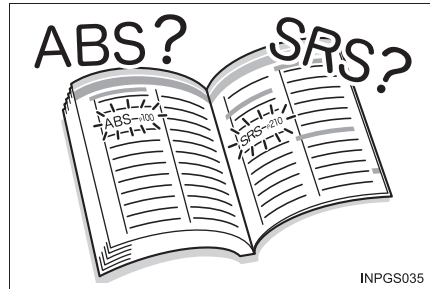

INPGS035

■ Searching by installation position

- Pictorial index P. 14



INPGS037

■ Searching by symptom or sound

- What to do if...
(Troubleshooting) P. 490



INPGS038

■ Searching by title

- Table of contents P. 2

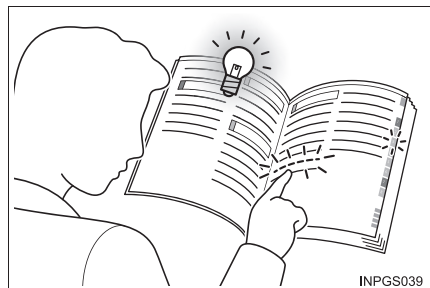

INPGS039

Pictorial index

Exterior

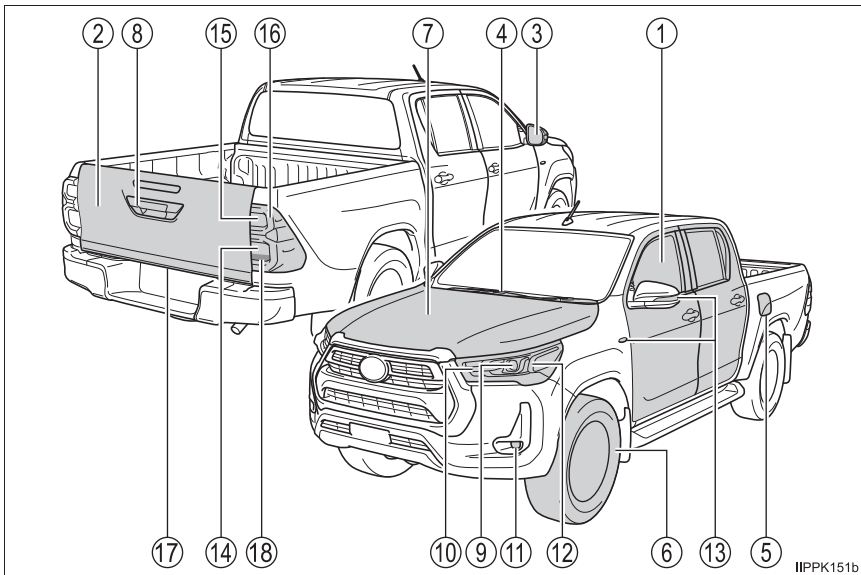

IIPPK151b

The shape of the exterior lights may differ depending on the grade etc. (→P. 381)

- | | | |
|---|---|---------------|
| ① | Side doors | P. 111 |
| | Access panels (smart-cab models only) | P. 116 |
| | Locking/unlocking | P. 111 |
| | Opening/closing the door glasses | P. 142 |
| | Locking/unlocking by using the mechanical key* ¹ | P. 450 |
| | Warning messages | P. 113 |
| ② | Tailgate * ¹ | P. 117 |
| ③ | Outside rear view mirrors | P. 139 |
| | Adjusting the mirror angle | P. 139 |
| | Folding the mirrors | P. 140 |
| | Defogging the mirrors* ¹ | P. 313 |
| ④ | Windshield wipers | P. 205 |
| | Precautions against winter season | P. 301 |

- ⑤ **Fuel filler door**^{*1} P. 208
 - Refueling method P. 208
 - Fuel type/fuel tank capacity P. 470
- ⑥ **Tires** P. 364
 - Tire size/inflation pressure P. 478
 - Winter tires/tire chain P. 301
 - Checking/rotation P. 365
 - Coping with flat tires P. 431
- ⑦ **Hood** P. 349
 - Opening P. 349
 - Engine oil P. 471
 - Coping with overheat P. 459
- ⑧ **Camera**^{*1, 2}

Light bulbs of the exterior lights for driving

(Replacing method: P. 381, Watts: P. 480)

- ⑨ **Headlights** P. 200
- ⑩ **Front position lights/daytime running lights** P. 200
- ⑪ **Fog lights**^{*1} P. 204
- ⑫ **Front turn signal lights** P. 198
- ⑬ **Side turn signal lights (fender-mounted type or mirror-mounted type)** P. 198
- ⑭ **Rear turn signal lights** P. 198
- ⑮ **Stop lights** P. 200
 - Downhill assist control system^{*1} P. 291
- ⑯ **Tail lights** P. 200
- ⑰ **License plate light** P. 200
- ⑱ **Back-up lights**
 - Shifting the shift lever to R. P. 184, 191

^{*1}: If equipped

^{*2}: Refer to "Navigation and Multimedia System Owner's Manual" or "Multimedia Owner's Manual".

Instrument panel

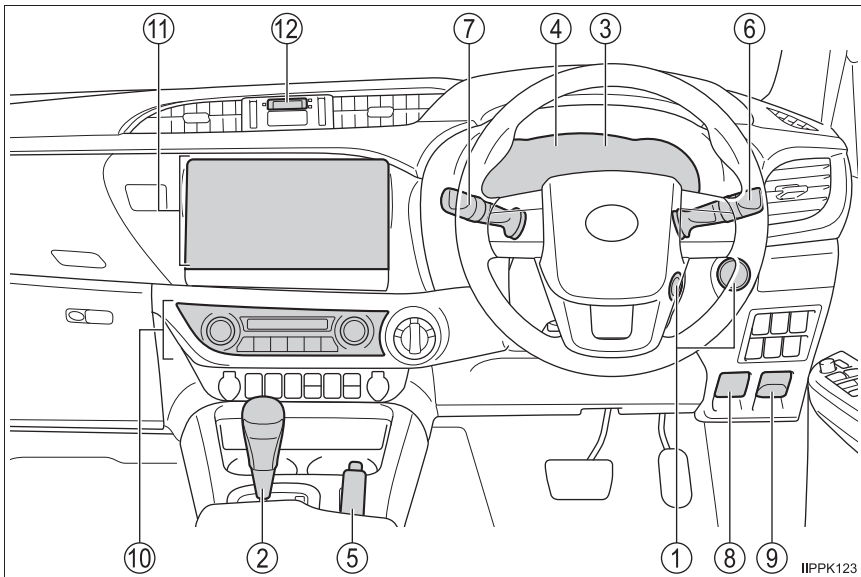

- ① **Engine switch** P. 173, 176
 Starting the engine/changing the positions or modes ... P. 173, 176
 Emergency stop of the engine P. 411
 When the engine will not start P. 448
 Warning messages P. 426
- ② **Shift lever (Automatic transmission)** P. 184
 Changing the shift position P. 184
 Precautions against towing P. 413
 When the shift lever does not move P. 189
- Shift lever (Manual transmission)** P. 191
 Changing the shift position P. 191
 Precautions against towing P. 413

③	Meters	P. 89
	Reading the meters	P. 89
	Adjusting the instrument panel light	P. 89
	Warning lights/indicator lights	P. 82
	When the warning lights come on	P. 421
④	Multi-information display	P. 92
	When the warning messages are displayed	P. 426
⑤	Parking brake lever	P. 199
	Applying/releasing	P. 199
	Precautions against winter season	P. 302
	Warning light/buzzer	P. 421
⑥	Turn signal lever	P. 198
	Headlight switch	P. 200
	Headlights/front position lights/tail lights/ daytime running lights	P. 200
	Fog lights* ¹	P. 204
⑦	Windshield wiper and washer switch	P. 205
	Usage	P. 205
	Adding washer fluid	P. 362
⑧	Hood lock release lever	P. 349
⑨	Fuel filler door opener * ¹	P. 210
⑩	Manual air conditioning system * ¹	P. 306
	Automatic air conditioning system * ¹	P. 311
⑪	Multimedia system * ^{1, 2}	
	Navigation system * ^{1, 2}	
	Rear view monitor system * ^{1, 2}	
⑫	Clock	P. 332

*¹: If equipped

*²: Refer to "Navigation and Multimedia System Owner's Manual" or
"Multimedia Owner's Manual".

Switches

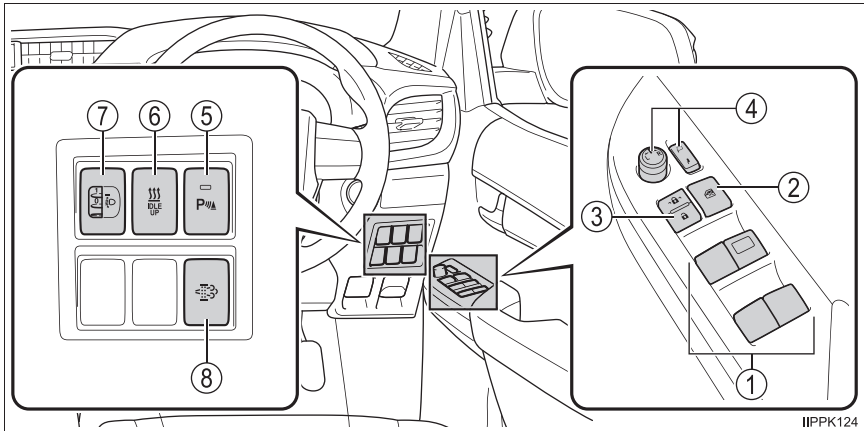

- ① Power window switches P. 142
- ② Window lock switch P. 143
- ③ Door lock switch P. 113
- ④ Outside rear view mirror switches P. 139
- ⑤ Toyota parking-assist sensor switch*¹ P. 262
- ⑥ Heater idle up switch*¹ P. 308, 314
- ⑦ Manual headlight leveling dial*¹ P. 201
- ⑧ DPF system switch*¹ P. 296

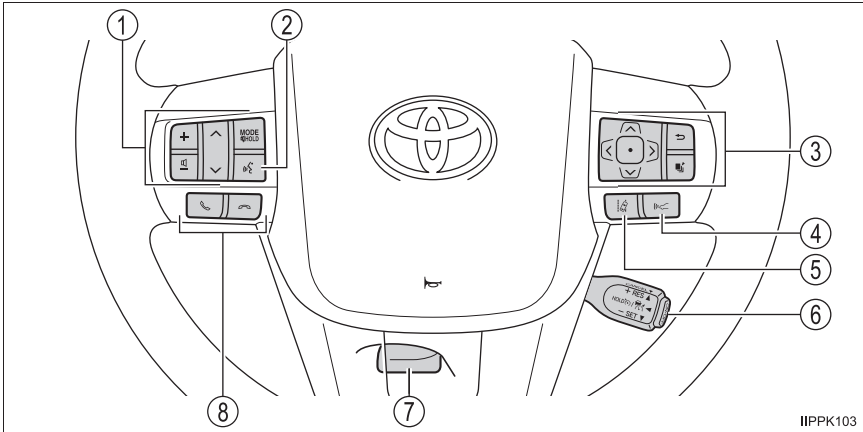

IIPPK103

- ① **Audio remote control switches***2
- ② **Talk switch***2
- ③ **Meter control switches** P. 93
- ④ **Vehicle-to-vehicle distance switch** P. 254
- ⑤ **LDA (Lane Departure Alert with Yaw Assist Function) switch** P. 231
- ⑥ **Cruise control switch**
Dynamic radar cruise control. P. 246
- ⑦ **Tilt steering lock release lever** P. 135
- ⑧ **Telephone switches***2 P. 93

*1: If equipped

*2: Refer to "Navigation and Multimedia System Owner's Manual" or "Multimedia Owner's Manual".

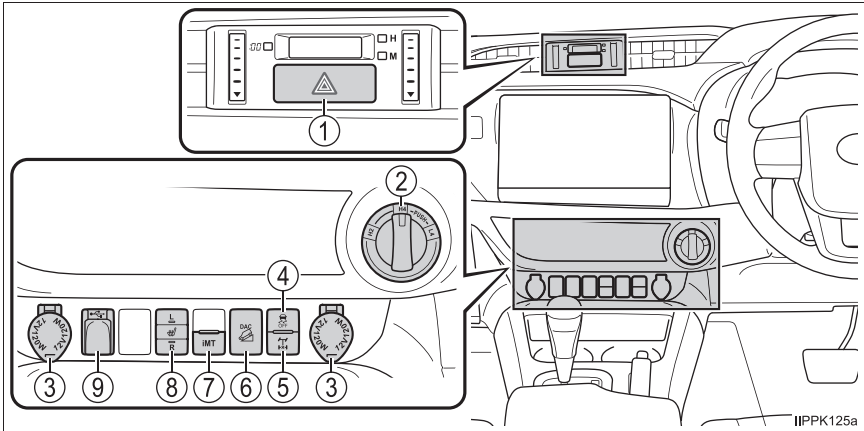

IIPPK125a

- ① Emergency flasher switch P. 410
- ② Front-wheel drive control switch*¹ P. 270
- ③ Power outlets*¹ P. 333
- ④ VSC OFF switch..... P. 286
- ⑤ Rear differential lock switch*¹ P. 280
- ⑥ “DAC” (Downhill Assist Control system) switch*¹ P. 291
- ⑦ “iMT” switch*¹ P. 193
- ⑧ Seat heater switches*¹ P. 319
- ⑨ USB port*²

Interior

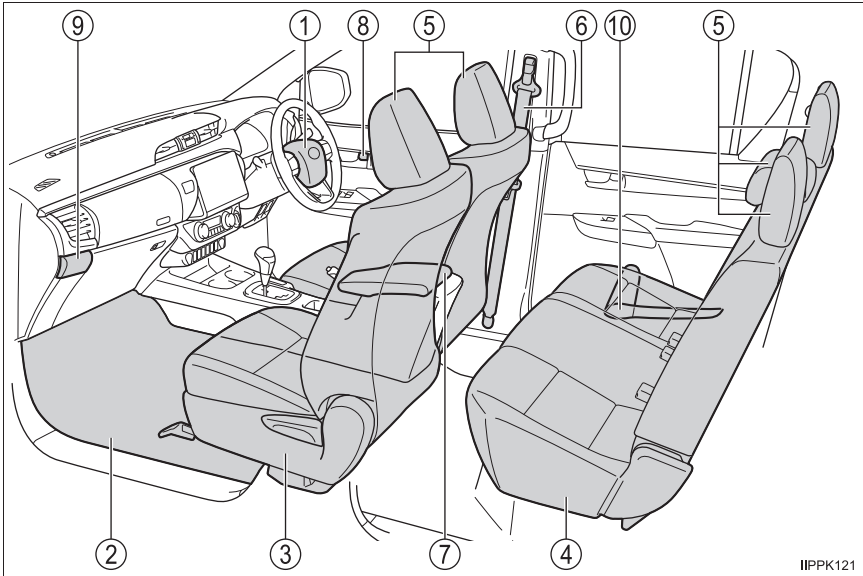

IIPPK121

①	SRS airbags	P. 35
②	Floor mats	P. 26
③	Front seats	P. 127
④	Rear seats *1	P. 129
⑤	Head restraints	P. 132
⑥	Seat belts	P. 30
⑦	Console box *1	P. 324
⑧	Inside lock buttons	P. 113
⑨	Cup holders	P. 325
	Auxiliary boxes	P. 327
⑩	Bottle holders *1	P. 326

*1: If equipped

*2: Refer to "Navigation and Multimedia System Owner's Manual" or "Multimedia Owner's Manual".

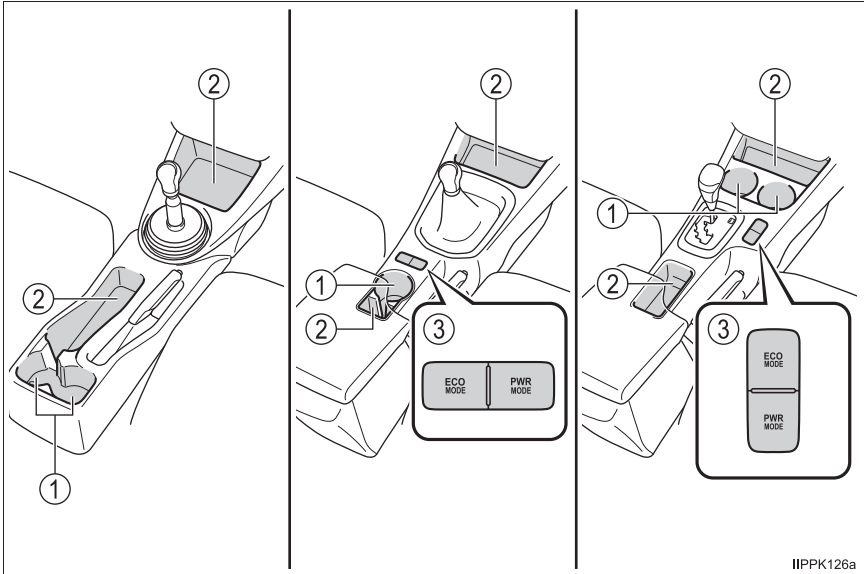

- ① Cup holders*1 P. 325
- ② Auxiliary boxes*1 P. 327
- ③ Driving mode select switches*1 P. 186, 192

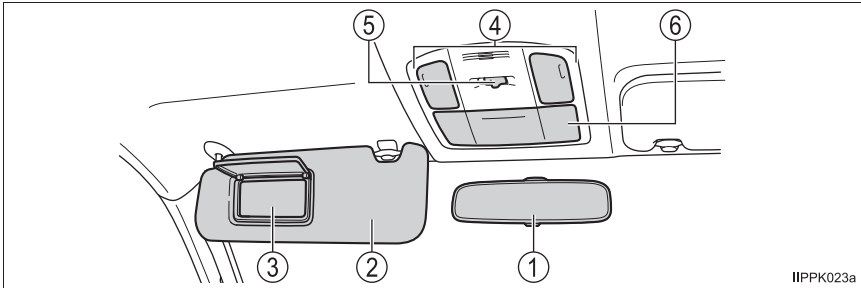

IIPPK023a

- ① Inside rear view mirror P. 137
- ② Sun visors*². P. 331
- ③ Vanity mirror*¹. P. 331
- ④ Personal lights. P. 321
Interior lights*^{1, 3}. P. 321
- ⑤ Personal/interior light main switch P. 321
- ⑥ Auxiliary boxes P. 327

*1: If equipped

*2: NEVER use a rearward facing child restraint on a seat protected by an ACTIVE AIRBAG in front of it, DEATH or SERIOUS INJURY to the CHILD can occur. (→P. 55)



*3: The illustration shows the front, but they are also equipped in the rear.

1-1. For safe use	
Before driving.....	26
For safe driving	28
Seat belts.....	30
SRS airbags.....	35
Exhaust gas precautions	45
1-2. Child safety	
Front passenger occupant classification system.....	46
Riding with children.....	51
Child restraint systems	52
1-3. Theft deterrent system	
Engine immobilizer system	77
Alarm	79

Before driving

Floor mat

Use only floor mats designed specifically for vehicles of the same model and model year as your vehicle. Fix them securely in place onto the carpet.

- 1 Insert the retaining hooks (clips) into the floor mat eyelets.

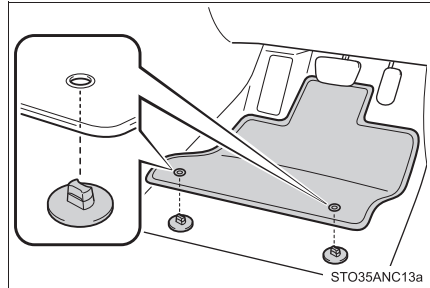

- 2 Turn the upper knob of each retaining hook (clip) to secure the floor mats in place.

*: Always align the \triangle marks.

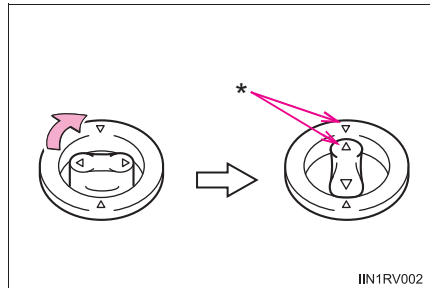

The shape of the retaining hooks (clips) may differ from that shown in the illustration.

⚠ WARNING

Observe the following precautions.

Failure to do so may cause the driver's floor mat to slip, possibly interfering with the pedals while driving. An unexpectedly high speed may result or it may become difficult to stop the vehicle. This could lead to an accident, resulting in death or serious injury.

■ When installing the driver's floor mat

- Do not use floor mats designed for other models or different model year vehicles, even if they are Toyota Genuine floor mats.
- Only use floor mats designed for the driver's seat.
- Always install the floor mat securely using the retaining hooks (clips) provided.
- Do not use two or more floor mats on top of each other.
- Do not place the floor mat bottom-side up or upside-down.

■ Before driving

- Check that the floor mat is securely fixed in the correct place with all the provided retaining hooks (clips). Be especially careful to perform this check after cleaning the floor.
- With the engine stopped and the shift lever in P (automatic transmission) or N (manual transmission), fully depress each pedal to the floor to make sure it does not interfere with the floor mat.

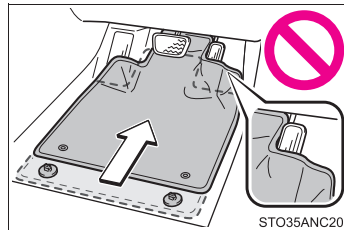

For safe driving

For safe driving, adjust the seat and mirror to an appropriate position before driving.

Correct driving posture

- ① Adjust the angle of the seat-back so that you are sitting straight up and so that you do not have to lean forward to steer. (→P. 127)
- ② Adjust the seat so that you can depress the pedals fully and so that your arms bend slightly at the elbow when gripping the steering wheel. (→P. 127)
- ③ Vehicles with adjustable type head restraint: Lock the head restraint in place with the center of the head restraint closest to the top of your ears. (→P. 132)
- ④ Wear the seat belt correctly. (→P. 30)

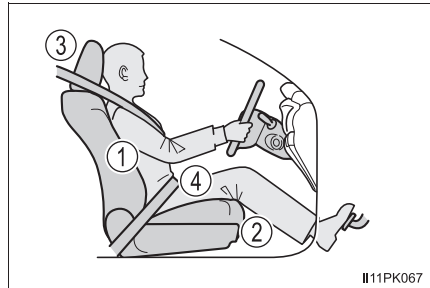

Correct use of the seat belts

Make sure that all occupants are wearing their seat belts before driving the vehicle. (→P. 30)

Use a child restraint system appropriate for the child until the child becomes large enough to properly wear the vehicle's seat belt.

(→P. 52)

Adjusting the mirrors

Make sure that you can see backward clearly by adjusting the inside and outside rear view mirrors properly. (→P. 137, 139)

WARNING

Observe the following precautions.

Failure to do so may result in death or serious injury.

- Do not adjust the position of the driver's seat while driving.
Doing so could cause the driver to lose control of the vehicle.
- Do not place a cushion between the driver or passenger and the seatback.
A cushion may prevent correct posture from being achieved, and reduce the effectiveness of the seat belt and head restraint.
- Do not place anything under the front seats.
Objects placed under the front seats may become jammed in the seat tracks and stop the seat from locking in place. This may lead to an accident and the adjustment mechanism may also be damaged.
- Always observe the legal speed limit when driving on public roads.
- When driving over long distances, take regular breaks before you start to feel tired.
Also, if you feel tired or sleepy while driving, do not force yourself to continue driving and take a break immediately.

Seat belts

Make sure that all occupants are wearing their seat belts before driving the vehicle.

Correct use of the seat belts

- Extend the shoulder belt so that it comes fully over the shoulder, but does not come into contact with the neck or slide off the shoulder.
- Position the lap belt as low as possible over the hips.
- Adjust the position of the seat-back. Sit up straight and well back in the seat.
- Do not twist the seat belt.

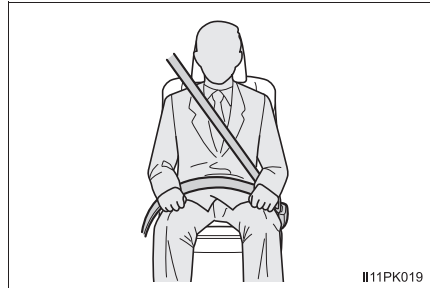

Fastening and releasing the seat belt

- ① To fasten the seat belt, push the plate into the buckle until a click sound is heard.
- ② To release the seat belt, press the release button.

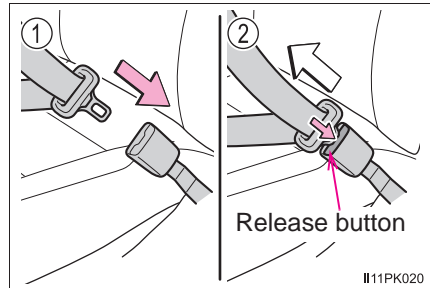

Adjusting the seat belt shoulder anchor height (if equipped for front seats)

- ① Push the seat belt shoulder anchor down while pulling the lock release knob.
- ② Push the seat belt shoulder anchor up.

Move the height adjuster up and down as needed until you hear a click.

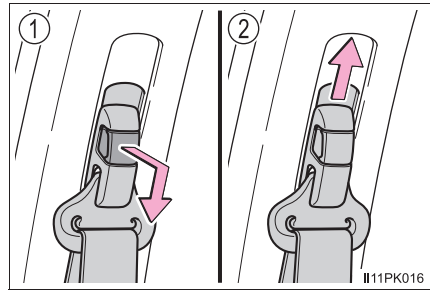

Seat belt pretensioners

► Single-cab models (front seats)

The pretensioners help the seat belts to quickly restrain the occupants by retracting the seat belts when the vehicle is subjected to certain types of severe frontal or side collision.

The pretensioners do not activate in the event of a minor frontal impact, a minor side impact, a rear impact or a vehicle rollover.

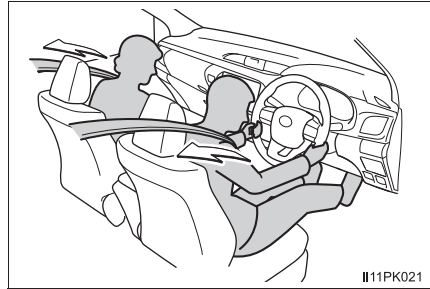

► Smart-cab and double-cab models (front and outboard rear seats)

The pretensioners help the seat belts to quickly restrain the occupants by retracting the seat belts when the vehicle is subjected to certain types of severe frontal or side collision.

The pretensioners do not activate in the event of a minor frontal impact, a minor side impact, a rear impact or a vehicle rollover.

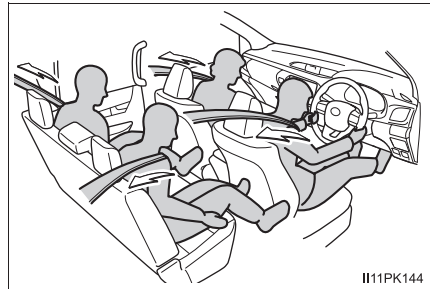

■ Emergency locking retractor (ELR)

The retractor will lock the belt during a sudden stop or on impact. It may also lock if you lean forward too quickly. A slow, easy motion will allow the belt to extend so that you can move around fully.

■ Child seat belt usage

The seat belts of your vehicle were principally designed for persons of adult size.

- Use a child restraint system appropriate for the child, until the child becomes large enough to properly wear the vehicle's seat belt. (→P. 52)
- When the child becomes large enough to properly wear the vehicle's seat belt, follow the instructions regarding seat belt usage. (→P. 30)

■ Replacing the belt after the pretensioner has been activated

If the vehicle is involved in multiple collisions, the pretensioner will activate for the first collision, but will not activate for the second or subsequent collisions.

■ Seat belt regulations

If seat belt regulations exist in the country where you reside, please contact your Toyota dealer for seat belt replacement or installation.

⚠ WARNING

Observe the following precautions to reduce the risk of injury in the event of sudden braking, sudden swerving or an accident.

Failure to do so may cause death or serious injury.

■ **Wearing a seat belt**

- Ensure that all passengers wear a seat belt.
- Always wear a seat belt properly.
- Each seat belt should be used by one person only. Do not use a seat belt for more than one person at once, including children.
- Toyota recommends that children be seated in the rear seat and always use a seat belt and/or an appropriate child restraint system.
- To achieve a proper seating position, do not recline the seat more than necessary. The seat belt is most effective when the occupants are sitting up straight and well back in the seats.
- Do not wear the shoulder belt under your arm.
- Always wear your seat belt low and snug across your hips.

■ **Pregnant women**

Obtain medical advice and wear the seat belt in the proper way. (→P. 30)

Women who are pregnant should position the lap belt as low as possible over the hips in the same manner as other occupants, extending the shoulder belt completely over the shoulder and avoiding belt contact with the rounding of the abdominal area.

If the seat belt is not worn properly, not only the pregnant woman, but also the fetus could suffer death or serious injury as a result of sudden braking or a collision.

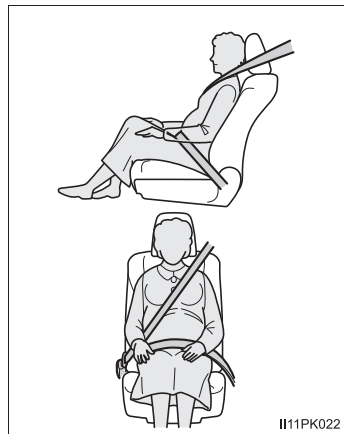

■ **People suffering illness**

Obtain medical advice and wear the seat belt in the proper way. (→P. 30)

 **WARNING****■ When children are in the vehicle**

→P. 71

■ Seat belt pretensioners

- Do not place anything, such as a cushion, on the front passenger's seat. Doing so will disperse the passenger's weight, which prevents the sensor from detecting the passenger's weight properly. As a result, the seat belt pretensioner for the front passenger's seat may not activate in the event of a collision.
- If the pretensioner has activated, the SRS warning light will come on. In that case, the seat belt cannot be used again and must be replaced at your Toyota dealer.

■ Adjustable shoulder anchor (if equipped)

Always make sure the shoulder belt is positioned across the center of your shoulder. The belt should be kept away from your neck, but not falling off your shoulder. Failure to do so could reduce the amount of protection in an accident and cause death or serious injuries in the event of a sudden stop, sudden swerve or accident. (→P. 31)

■ Seat belt damage and wear

- Do not damage the seat belts by allowing the belt, plate, or buckle to be jammed in the door.
- Inspect the seat belt system periodically. Check for cuts, fraying, and loose parts. Do not use a damaged seat belt until it is replaced. Damaged seat belts cannot protect an occupant from death or serious injury.
- Ensure that the belt and plate are locked and the belt is not twisted. If the seat belt does not function correctly, immediately contact your Toyota dealer.
- Replace the seat assembly, including the belts, if your vehicle has been involved in a serious accident, even if there is no obvious damage.
- Do not attempt to install, remove, modify, disassemble or dispose of the seat belts. Have any necessary repairs carried out by your Toyota dealer. Inappropriate handling may lead to incorrect operation.

SRS airbags

The SRS airbags inflate when the vehicle is subjected to certain types of severe impacts that may cause significant injury to the occupants. They work together with the seat belts to help reduce the risk of death or serious injury.

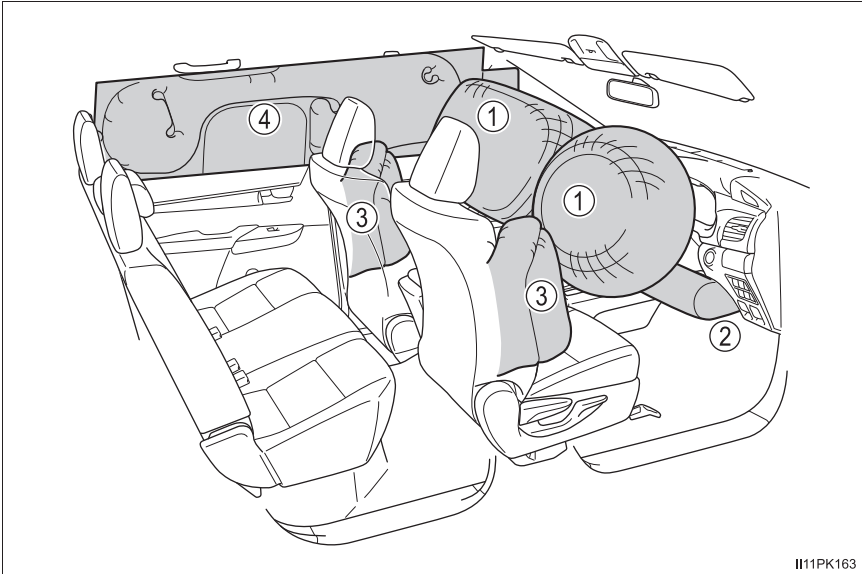

◆ SRS front airbags

- ① SRS driver airbag/front passenger airbag
Can help protect the head and chest of the driver and front passenger from impact with interior components
- ② SRS driver's knee airbag
Can help provide driver protection

◆ SRS side and curtain shield airbags

- ③ SRS side airbags
Can help protect the torso of the front seat occupants
- ④ SRS curtain shield airbags
Can help protect primarily the head of occupants in the outer seats

SRS airbag system components

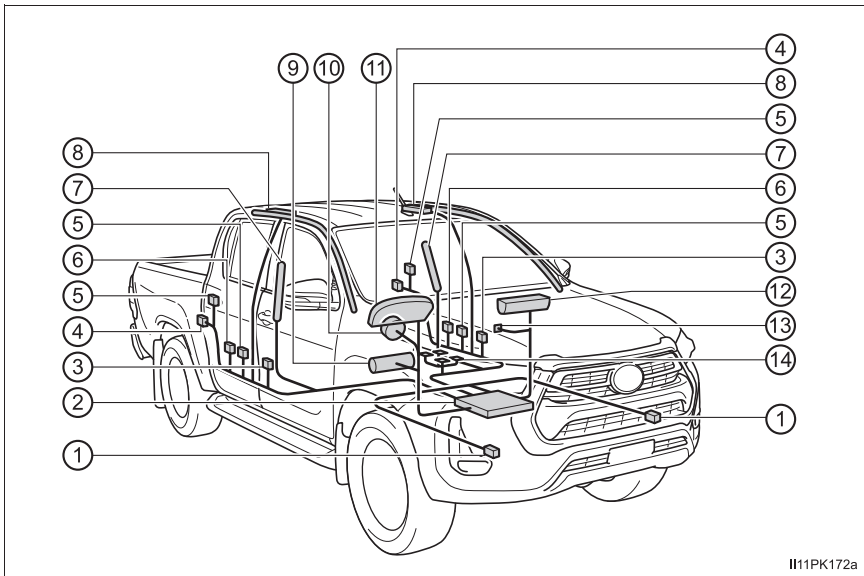

II11PK172a

- | | |
|--|--|
| ① Front impact sensors | ⑨ Driver's knee airbag |
| ② Airbag sensor assembly | ⑩ Driver airbag |
| ③ Side impact sensors (front door) | ⑪ SRS warning light |
| ④ Side impact sensors (rear) | ⑫ Front passenger airbag |
| ⑤ Seat belt pretensioners and force limiters | ⑬ "PASSENGER AIR BAG" indicator |
| ⑥ Safing sensor (front) | ⑭ Front passenger occupant classification system (ECU and sensors) |
| ⑦ Side airbags | |
| ⑧ Curtain shield airbags | |

The main SRS airbag system components are shown above. The SRS airbag system is controlled by the airbag sensor assembly. As the airbags deploy, a chemical reaction in the inflators quickly fills the airbags with non-toxic gas to help restrain the motion of the occupants.

 **WARNING****■ SRS airbag precautions**

Observe the following precautions regarding the SRS airbags. Failure to do so may cause death or serious injury.

- The driver and all passengers in the vehicle must wear their seat belts properly.

The SRS airbags are supplemental devices to be used with the seat belts.

- The SRS driver airbag deploys with considerable force, and can cause death or serious injury especially if the driver is very close to the airbag.

Since the risk zone for the driver's airbag is the first 50 - 75 mm (2 - 3 in.) of inflation, placing yourself 250 mm (10 in.) from your driver airbag provides you with a clear margin of safety. This distance is measured from the center of the steering wheel to your breastbone. If you sit less than 250 mm (10 in.) away now, you can change your driving position in several ways:

- Move your seat to the rear as far as you can while still reaching the pedals comfortably.
- Slightly recline the back of the seat. Although vehicle designs vary, many drivers can achieve the 250 mm (10 in.) distance, even with the driver seat all the way forward, simply by reclining the back of the seat somewhat. If reclining the back of your seat makes it hard to see the road, raise yourself by using a firm, non-slippery cushion, or raise the seat if your vehicle has that feature.
- If your steering wheel is adjustable, tilt it downward. This points the airbag toward your chest instead of your head and neck.

The seat should be adjusted as recommended above, while still maintaining control of the foot pedals, steering wheel, and your view of the instrument panel controls.

- The SRS front passenger airbag also deploys with considerable force, and can cause death or serious injury especially if the front passenger is very close to the airbag. The front passenger seat should be as far from the airbag as possible with the seatback adjusted, so the front passenger sits upright.
- Improperly seated and/or restrained infants and children can be killed or seriously injured by a deploying airbag. An infant or child who is too small to use a seat belt should be properly secured using a child restraint system. Toyota strongly recommends that all infants and children be placed in the rear seats (if equipped) of the vehicle and properly restrained. The rear seats (if equipped) are safer for infants and children than the front passenger seat. (→P. 52)

⚠ WARNING**■ SRS airbag precautions**

- Do not sit on the edge of the seat or lean against the dashboard.

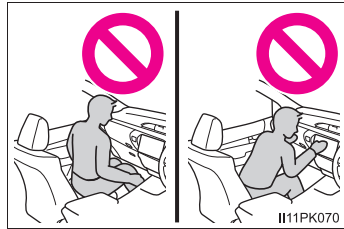

- Do not allow a child to stand in front of the SRS front passenger airbag unit or sit on the knees of a front passenger.
- Do not allow the front seat occupants to hold items on their knees.

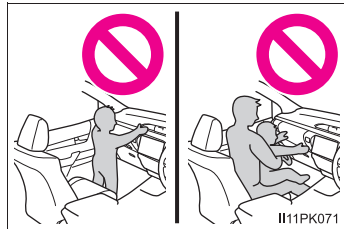

- Do not lean against the door, the roof side rail or the front, side and rear pillars.



- Do not allow anyone to kneel on the passenger seat toward the door or put their head or hands outside the vehicle.

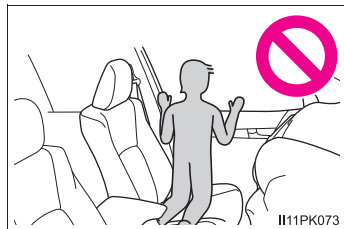

⚠ WARNING

■ SRS airbag precautions

- Do not attach anything to or lean anything against areas such as the dashboard, steering wheel pad and lower portion of the instrument panel. These items can become projectiles when the SRS driver, front passenger and knee airbags deploy.

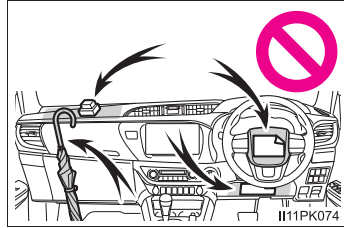

- Do not attach anything to areas such as a door, windshield, side door glass, front or rear pillar, roof side rail and assist grip.

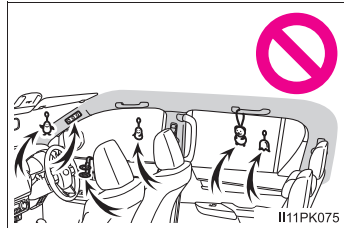

- Vehicles without smart entry & start system: Do not attach any heavy, sharp or hard objects such as keys or accessories to the key. The objects may restrict the SRS knee airbag inflation or be thrust into the driver's seat area by the force of the deploying airbag, thus causing a danger.

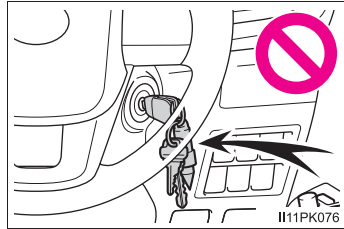

- Double-cab models: Do not hang coat hangers or other hard objects on the coat hooks. All of these items could become projectiles and may cause death or serious injury, should the SRS curtain shield airbags deploy.
- If the vinyl cover is put on the area where the SRS knee airbag will deploy, be sure to remove it.
- Do not use seat accessories which cover the parts where the SRS side airbags inflate as they may interfere with inflation of the SRS airbags. Such accessories may prevent the side airbags from activating correctly, disable the system or cause the side airbags to inflate accidentally, resulting in death or serious injury.

 **WARNING****■ SRS airbag precautions**

- Do not strike or apply significant levels of force to the area of the SRS airbag components.
Doing so can cause the SRS airbags to malfunction.
- Do not touch any of the component parts immediately after the SRS airbags have deployed (inflated) as they may be hot.
- If breathing becomes difficult after the SRS airbags have deployed, open a door or window to allow fresh air in, or leave the vehicle if it is safe to do so. Wash off any residue as soon as possible to prevent skin irritation.
- If the areas where the SRS airbags are stored, such as the steering wheel pad and front and rear pillar garnishes, are damaged or cracked, have them replaced by your Toyota dealer.
- Do not place anything, such as a cushion, on the front passenger's seat. Doing so will disperse the passenger's weight, which prevents the sensor from detecting the passenger's weight properly. As a result, the SRS front airbags for the front passenger may not deploy in the event of a collision.

■ Modification and disposal of SRS airbag system components

Do not dispose of your vehicle or perform any of the following modifications without consulting your Toyota dealer. The SRS airbags may malfunction or deploy (inflate) accidentally, causing death or serious injury.

- Installation, removal, disassembly and repair of the SRS airbags
- Repairs, modifications, removal or replacement of the steering wheel, instrument panel, dashboard, seats or seat upholstery, front, side and rear pillars or roof side rails
- Repairs or modifications of the front fender, front bumper, or side of the occupant compartment
- Installation of a grille guard (bull bars, kangaroo bar, etc.), snow plows or winches
- Modifications to the vehicle's suspension system
- Installation of electronic devices such as mobile two-way radios (RF-transmitter) and CD players

■ If the SRS airbags deploy (inflate)

- Slight abrasions, burns, bruising etc., may be sustained from SRS airbags, due to the extremely high speed deployment (inflation) by hot gases.
- A loud noise and white powder will be emitted.
- Parts of the airbag module (steering wheel hub, airbag cover and inflator) as well as the front seats, parts of the front and rear pillars, and roof side rails, may be hot for several minutes. The airbag itself may also be hot.
- The windshield may crack.
- Fuel supply to the engine will be stopped. (Gasoline engine) (→P. 420)

■ SRS airbag deployment conditions (SRS front airbags)

- The SRS front airbags will deploy in the event of an impact that exceeds the set threshold level (the level of force corresponding to an approximately 20 - 30 km/h [12 - 18 mph] frontal collision with a fixed wall that does not move or deform).

However, this threshold velocity will be considerably higher in the following situations:

- If the vehicle strikes an object, such as a parked vehicle or sign pole, which can move or deform on impact
- If the vehicle is involved in an underride collision, such as a collision in which the front of the vehicle “underrides”, or goes under, the bed of a truck
- Depending on the type of collision, it is possible that only the seat belt pretensioners will activate.
- The SRS front airbags for the front passenger will not activate if there is no passenger sitting in the front passenger seat. However, the SRS front airbags for the front passenger may deploy if luggage is put in the seat, even if the seat is unoccupied.

■ SRS airbag deployment conditions (SRS side and curtain shield airbags)

- The SRS side and curtain shield airbags will deploy in the event of an impact that exceeds the set threshold level (the level of force corresponding to the impact force produced by an approximately 1500 kg [3300 lb.] vehicle colliding with the vehicle cabin from a direction perpendicular to the vehicle orientation at an approximate speed of 20 - 30 km/h [12 - 18 mph]).
- All SRS side and curtain shield airbags will deploy in the event of a severe frontal collision.

■ Conditions under which the SRS airbags may deploy (inflate), other than a collision

The SRS front airbags, SRS side and curtain shield airbags may also deploy if a serious impact occurs to the underside of your vehicle. Some examples are shown in the illustration.

- Hitting a curb, edge of pavement or hard surface
- Falling into or jumping over a deep hole
- Landing hard or falling

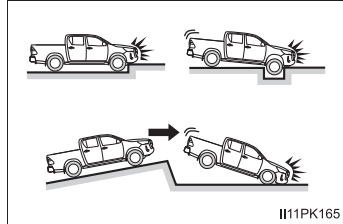

■ Types of collisions that may not deploy the SRS airbags (SRS front airbags)

The SRS front airbags do not generally inflate if the vehicle is involved in a side or rear collision, if it rolls over, or if it is involved in a low-speed frontal collision. But, whenever a collision of any type causes sufficient forward deceleration of the vehicle, deployment of the SRS front airbags may occur.

- Collision from the side
- Collision from the rear
- Vehicle rollover

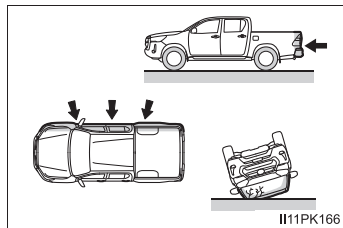

■ Types of collisions that may not deploy the SRS airbags (SRS side and curtain shield airbags)

The SRS side and curtain shield airbags may not activate if the vehicle is subjected to a collision from the side at certain angles, or a collision to the side of the vehicle body other than the passenger compartment.

- Collision from the side to the vehicle body other than the passenger compartment
- Collision from the side at an angle

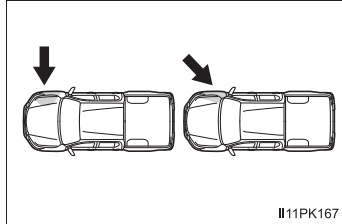

The SRS side and curtain shield airbags do not generally inflate if the vehicle is involved in a rear collision, if it rolls over, or if it is involved in a low-speed side or low-speed frontal collision.

- Collision from the rear
- Vehicle rollover

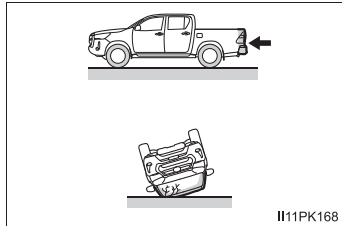

■ When to contact your Toyota dealer

In the following cases, the vehicle will require inspection and/or repair. Contact your Toyota dealer as soon as possible.

- Any of the SRS airbags have been inflated.
- The front of the vehicle is damaged or deformed, or was involved in an accident that was not severe enough to cause the SRS airbags to inflate.

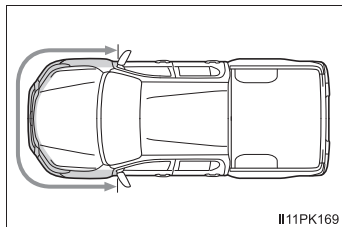

- A portion of a door or its surrounding area is damaged or deformed, or the vehicle was involved in an accident that was not severe enough to cause the SRS side and curtain shield airbags to inflate.

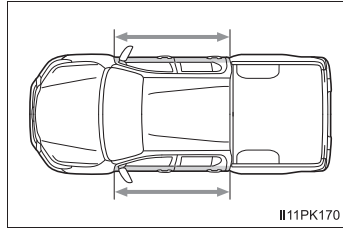

- The pad section of the steering wheel, dashboard near the front passenger airbag cover or lower portion of the instrument panel is scratched, cracked, or otherwise damaged.

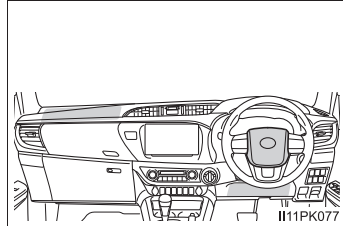

- The surface of the seats with the SRS side airbag is scratched, cracked, or otherwise damaged.

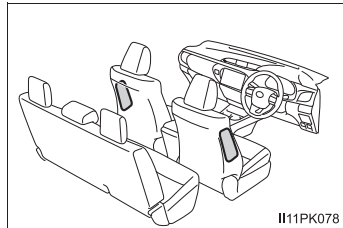

- The portion of the front pillars, rear pillars or roof side rail garnishes (padding) containing the SRS curtain shield airbags inside is scratched, cracked, or otherwise damaged.

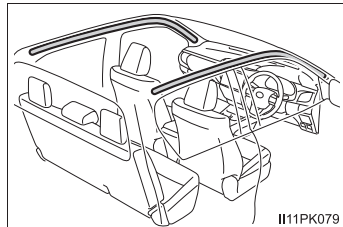

Exhaust gas precautions

Harmful substance to the human body is included in exhaust gases if inhaled.

WARNING

Exhaust gases include harmful carbon monoxide (CO), which is colorless and odorless. Observe the following precautions.

Failure to do so may cause exhaust gases enter the vehicle and may lead to an accident caused by light-headedness, or may lead to death or a serious health hazard.

■ Important points while driving

If you smell exhaust gases in the vehicle, open the windows and have the vehicle inspected at your Toyota dealer as soon as possible.

■ When parking

- If the vehicle is in a poorly ventilated area or a closed area, such as a garage, stop the engine.
- Do not leave the vehicle with the engine running for a long time.
If such a situation cannot be avoided, park the vehicle in an open space and ensure that exhaust fumes do not enter the vehicle interior.
- Do not leave the engine running in an area with snow build-up, or where it is snowing. If snowbanks build up around the vehicle while the engine is running, exhaust gases may collect and enter the vehicle.

■ Exhaust pipe

The exhaust system needs to be checked periodically. If there is a hole or crack caused by corrosion, damage to a joint or abnormal exhaust noise, be sure to have the vehicle inspected and repaired by your Toyota dealer.

Front passenger occupant classification system

Your vehicle is equipped with a front passenger occupant classification system. This system detects the conditions of the front passenger seat and activates or deactivates the front passenger airbag and front passenger's seat belt pretensioner.

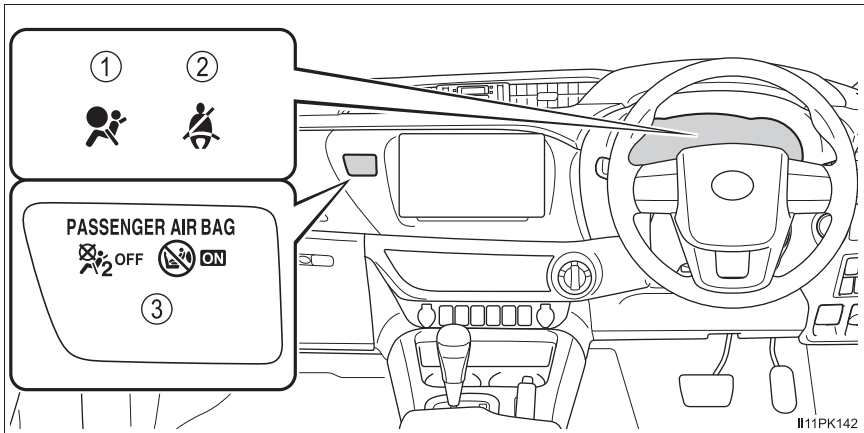

- ① SRS warning light
- ② Seat belt reminder light
- ③ “PASSENGER AIR BAG” indicator

Vehicles without smart entry & start system: The ON indicator light turns on when the airbag system is on (only when the engine switch is in the “ON” position).

Vehicles with smart entry & start system: The ON indicator light turns on when the airbag system is on (only when the engine switch is in IGNITION ON mode).

Condition and operation in the front passenger occupant classification system

■ Adult*¹

Indicator/ warning light	"PASSENGER AIR BAG" indicator	ON indicator
	SRS warning light	Off
	Seat belt reminder light	Off* ² or flashing* ³
Devices	Front passenger airbag	Activated
	Front passenger's seat belt pretensioner	

■ Child*⁴ or child restraint system*⁵

Indicator/ warning light	"PASSENGER AIR BAG" indicator	OFF indicator* ⁶
	SRS warning light	Off
	Seat belt reminder light	Off* ² or flashing* ³
Devices	Front passenger airbag	Deactivated
	Front passenger's seat belt pretensioner	Activated

■ Unoccupied

Indicator/ warning light	“PASSENGER AIR BAG” indicator	OFF indicator
	SRS warning light	Off
	Seat belt reminder light	
Devices	Front passenger airbag	Deactivated
	Front passenger’s seat belt pretensioner	Activated* ⁷ or deactivated* ⁸

■ There is a malfunction in the system

Indicator/ warning light	“PASSENGER AIR BAG” indicator	OFF indicator
	SRS warning light	On
	Seat belt reminder light	flashing
Devices	Front passenger airbag	Deactivated
	Front passenger’s seat belt pretensioner	Activated

- *1: The system judges a person of adult size as an adult. When a smaller adult sits in the front passenger seat, the system may recognize him/her as a child depending on his/her physique and posture.
- *2: In the event the front passenger is wearing a seat belt.
- *3: In the event the front passenger does not wear a seat belt.
- *4: When a larger child who has outgrown a child restraint system sits in the front passenger seat, the system may recognize him/her as an adult depending on his/her physique or posture.
- *5: For the child's safety, install the child restraint system to a rear seat. When it is unavoidable, a child restraint system can be installed on the front passenger seat. A rear-facing child restraint system should be installed when "OFF" of the "PASSENGER AIR BAG" indicator is illuminated. (→P. 52)
- *6: In case the indicator light is not illuminated, consult this manual on how to install the child restraint system properly. (→P. 52)
- *7: In the event of a side collision.
- *8: In the event of a frontal collision.

 **WARNING**

■ Front passenger occupant classification system precautions

Observe the following precautions regarding the front passenger occupant classification system.

Failure to do so may cause death or serious injury.

- Wear the seat belt properly.
- Make sure the front passenger's seat belt plate has not been left inserted into the buckle before someone sits in the front passenger seat.
- Do not apply a heavy load to the front passenger seat or equipment (e.g. seatback pocket or armrest).
- Do not put weight on the front passenger seat by putting your hands or feet on the front passenger seat seatback from the rear passenger seat.
- Do not let a rear passenger lift the front passenger seat with their feet or press on the seatback with their legs.
- Do not put objects under the front passenger seat.

 **WARNING****■ Front passenger occupant classification system precautions**

- Do not recline the front passenger seatback so far that it touches a rear seat. This may cause “OFF” of the “PASSENGER AIR BAG” indicator to be illuminated, which indicates that the SRS airbags for the front passenger will not activate in the event of a severe accident. If the seatback touches the rear seat, return the seatback to a position where it does not touch the rear seat. Keep the front passenger seatback as upright as possible when the vehicle is moving. Reclining the seatback excessively may lessen the effectiveness of the seat belt system.
- If an adult sits in the front passenger seat, “ON” of the “PASSENGER AIR BAG” indicator is illuminated. If “OFF” of the “PASSENGER AIR BAG” indicator is illuminated, ask the passenger to sit up straight, well back in the seat, feet on the floor, and with the seat belt worn correctly. If “OFF” of the “PASSENGER AIR BAG” indicator still remains illuminated, either ask the passenger to move to the rear seat, or if that is not possible, move the front passenger seat fully rearward.
- When it is unavoidable to install a forward-facing child restraint system on the front passenger seat, install the child restraint system on the front passenger seat in the proper order. (→P. 52)
- Do not modify or remove the front seats.
- Do not kick the front passenger seat or subject it to severe impact. Otherwise, the SRS warning light may come on to indicate a malfunction of the front passenger occupant classification system. In this case, contact your Toyota dealer immediately.
- Child restraint systems installed on the rear seat should not contact the front seatbacks.
- Do not use a seat accessory, such as a cushion and seat cover, that covers the seat cushion surface.
- Do not modify or replace the upholstery of the front seat.
- When it is unavoidable to install a rear-facing child restraint system on the front passenger seat, do not release the seat belt while the vehicle is moving. Doing so may cause the airbag system to be on.

Riding with children

Observe the following precautions when children are in the vehicle.

Use a child restraint system appropriate for the child, until the child becomes large enough to properly wear the vehicle's seat belt.

- It is recommended that children sit in the rear seats (if equipped) to avoid accidental contact with the shift lever, wiper switch etc.
- Use the rear door child-protector lock (double-cab models only) or the window lock switch to avoid children opening the door while driving or operating the power window accidentally.
- Do not let small children operate equipment which may catch or pinch body parts, such as the power window, hood, tailgate (if equipped), seats etc.



WARNING

Never leave children unattended in the vehicle, and never allow children to have or use the key.

Children may be able to start the vehicle or shift the vehicle into neutral. There is also a danger that children may injure themselves by playing with the windows or other features of the vehicle. In addition, heat build-up or extremely cold temperatures inside the vehicle can be fatal to children.

Child restraint systems

Before installing a child restraint system in the vehicle, there are precautions that need to be observed, different types of child restraint systems, as well as installation methods, etc., written in this manual.

Use a child restraint system when riding with a small child that cannot properly use a seat belt. For the child's safety, install the child restraint system to a rear seat. Be sure to follow the installation method that is in the operation manual enclosed with the restraint system.

Table of contents

Points to remember.....	P. 52
When using a child restraint system	P. 54
Child restraint system compatibility for each seating position....	P. 57
Child restraint system installation method	P. 69
• Fixed with a seat belt	P. 70
• Fixed with an ISOFIX rigid anchor (if equipped)	P. 72
• Using a child restraint anchor fitting (if equipped)	P. 74

Points to remember

- Prioritize and observe the warnings, as well as the laws and regulations for child restraint systems.
- Use a child restraint system until the child becomes large enough to properly wear the vehicle's seat belt.
- Choose a child restraint system appropriate to the age and size of the child.
- Note that not all child restraint systems can fit in all vehicles.

Before using or purchasing a child restraint system, check the compatibility of the child restraint system with seat positions. (→P. 57)

 **WARNING****■ When a child is riding**

Observe the following precautions.

Failure to do so may result in death or serious injury.

- For effective protection in automobile accidents and sudden stops, a child must be properly restrained, using a seat belt or child restraint system which is correctly installed. For installation details, refer to the operation manual enclosed with the child restraint system. General installation instruction is provided in this manual.
- Toyota strongly urges the use of a proper child restraint system that conforms to the weight and size of the child, installed on the rear seat. According to accident statistics, the child is safer when properly restrained in the rear seat than in the front seat.
- Holding a child in your or someone else's arms is not a substitute for a child restraint system. In an accident, the child can be crushed against the windshield or between the holder and the interior of the vehicle.

■ Handling the child restraint system

If the child restraint system is not properly fixed in place, the child or other passengers may be seriously injured or even killed in the event of sudden braking, sudden swerving, or an accident.

- If the vehicle were to receive a strong impact from an accident, etc., it is possible that the child restraint system has damage that is not readily visible. In such cases, do not reuse the restraint system.
- Depending on the child restraint system, installation may be difficult or impossible. In those cases, check whether the child restraint system is suitable for installment in the vehicle. (→P. 57) Be sure to install and observe the usage rules after carefully reading the child restraint system fixing method in this manual, as well as the operation manual enclosed with the child restraint system.
- Keep the child restraint system properly secured on the seat even if it is not in use. Do not store the child restraint system unsecured in the passenger compartment.
- If it is necessary to detach the child restraint system, remove it from the vehicle.

When using a child restraint system

■ When installing a child restraint system to a passenger seat

For the safety of a child, install child restraint systems to a rear seats. When installing child restraint system to a front passenger seat is unavoidable, adjust the seat as follows and install the child restraint system.

- Adjust the seatback angle to the most upright position.

When installing a forward-facing child seat, if there is a gap between the child seat and the seatback, adjust the seatback angle until good contact is achieved.

- Move the front seat fully rearward. If the passenger seat height can be adjusted, move it to the upper most position.
- If the head restraint interferes with your child restraint system, and the head restraint can be removed, remove the head restraint. Otherwise, put the head restraint in the upper most position.



⚠ WARNING

■ When using a child restraint system

Observe the following precautions.

Failure to do so may result in death or serious injury.

- Never use a rear-facing child restraint system on the front passenger seat when "ON" of the "PASSENGER AIR BAG" indicator is illuminated. (→P. 46)

The force of the rapid inflation of the front passenger airbag can cause death or serious injury to children in the event of an accident.

- There is a label(s) on the passenger side sun visor, indicating it is forbidden to attach a rear-facing child restraint system to the front passenger seat. Details of the label(s) are shown in the illustration below.

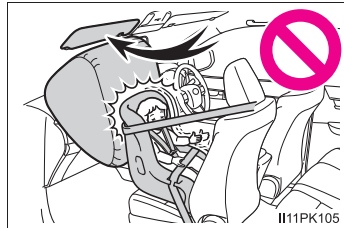

STY12ZY001

⚠ WARNING

■ When using a child restraint system

- Only put a forward-facing child restraint system on the front seat when unavoidable. When installing a forward-facing child restraint on the front passenger seat, move the seat as far back as possible. Failing to do so may result in death or serious injury if the airbags deploy (inflate).

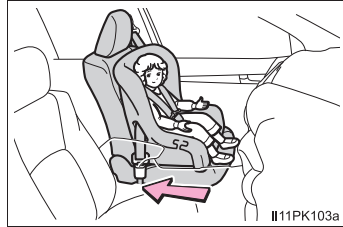

- Do not allow the child to lean his/her head or any part of his/her body against the door or the area of the seat, front or rear pillars, or roof side rails from which the SRS side airbags or SRS curtain shield airbags deploy even if the child is seated in the child restraint system. It is dangerous if the SRS side airbags and curtain shield airbags inflate, and the impact could cause death or serious injury to the child.

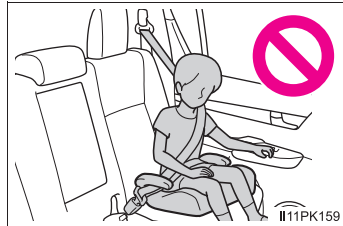

- When a junior seat (booster seat) is installed, always ensure that the shoulder belt is positioned across the center of the child's shoulder. The belt should be kept away from the child's neck, but not so that it could fall off the child's shoulder.
- Use child restraint system suitable to the age and size of the child and install it to the rear seat.

- Double-cab models: If the driver's seat interferes with the child restraint system and prevents it from being attached correctly, attach the child restraint system to the left-hand rear seat.
- Double-cab models: Adjust the front passenger seat so that it does not interfere with the child restraint system.

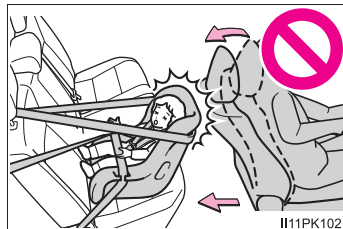

Child restraint system compatibility for each seating position

■ Child restraint system compatibility for each seating position

Compatibility of each seating position with child restraint systems (→P. 59) displays the type of child restraint systems that can be used and possible seating positions for installation using symbols.

Check the selected child restraint system together with the following [Before confirming the compatibility of each seating position with child restraint systems].

■ Before confirming the compatibility of each seating position with child restraint systems

1 Checking the child restraint system standards.

Use a child restraint system that conforms to UN(ECE) R44*¹ or UN(ECE) R129*^{1, 2}.

The following approval mark is displayed on child restraint systems which are conformed.

Check for an approval mark attached to the child restraint system.

Example of the displayed regulation number

① UN(ECE) R44 approval mark*³

The weight range of the child who is applicable for an UN(ECE) R44 approval mark is indicated.

② UN(ECE) R129 approval mark*³

The height range of the child who is applicable as well as available weights for an UN(ECE) R129 approval mark is indicated.

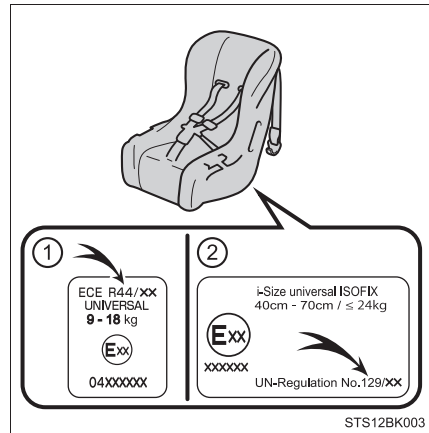

- *1: UN(ECE) R44 and UN(ECE) R129 are U.N. regulations for child restraint systems.
- *2: The child restraint systems mentioned in the table may not be available outside of the EU area.
- *3: The displayed mark may differ depending on the product.

2 Checking the category of the child restraint system.

Check the approval mark of the child restraint system for which of the following categories the child restraint system is suitable.

Also, if there are any uncertainties, check the user's guide included with the child restraint system or contact the retailer of the child restraint system.

- “universal”
- “semi-universal”
- “restricted”
- “vehicle specific”

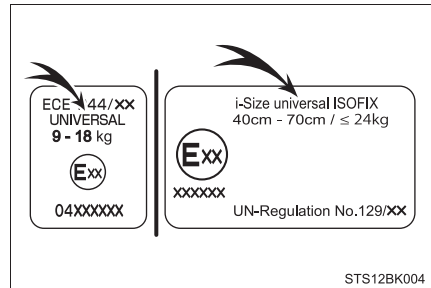

STS12BK004

■ Compatibility of each seating position with child restraint systems

▶ Single-cab models

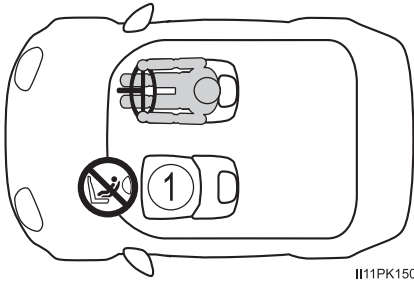

*1, 2, 3 ①	*4 U
---------------	---------



Suitable for “universal” category child restraint system fixed with the seat belt.



Never use a rear-facing child restraint system on the front passenger seat when “ON” of the “PASSENGER AIR BAG” indicator is illuminated.

*1: Move the front seat fully rearward. If the passenger seat height can be adjusted, move it to the upper most position.

*2: Adjust the seatback angle to the most upright position.

When installing a forward-facing child seat, if there is a gap between the child seat and the seatback, adjust the seatback angle until good contact is achieved.

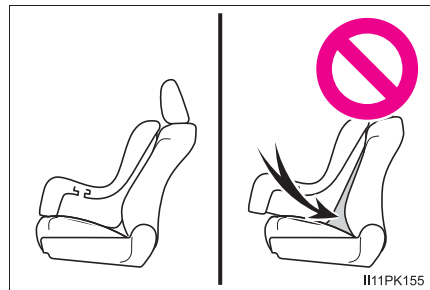

*3: If the head restraint interferes with your child restraint system, and the head restraint can be removed, remove the head restraint. Otherwise, put the head restraint in the upper most position.

*4: Use only a front-facing child restraint system when “ON” of the “PASSENGER AIR BAG” indicator is illuminated.

► Smart-cab models

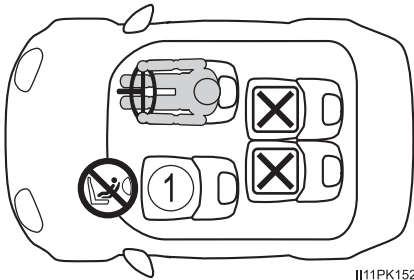

II11PK152

*1, 2, 3 ①	*4 U
---------------	---------



Suitable for “universal” category child restraint system fixed with the seat belt.



Not suitable for child restraint system.



Never use a rear-facing child restraint system on the front passenger seat when “ON” of the “PASSENGER AIR BAG” indicator is illuminated.

*1: Move the front seat fully rearward. If the passenger seat height can be adjusted, move it to the upper most position.

*2: Adjust the seatback angle to the most upright position. When installing a forward-facing child seat, if there is a gap between the child seat and the seatback, adjust the seatback angle until good contact is achieved.

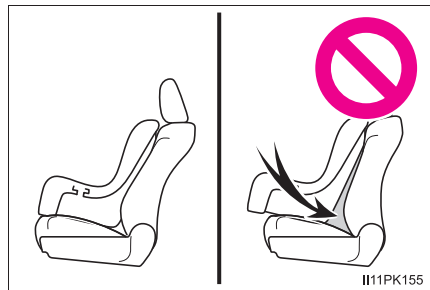

II11PK155



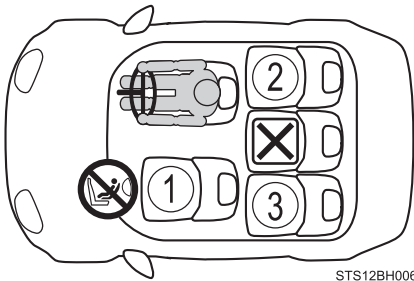

*3: If the head restraint interferes with your child restraint system, and the head restraint can be removed, remove the head restraint. Otherwise, put the head restraint in the upper most position.

*4: Use only a front-facing child restraint system when “ON” of the “PASSENGER AIR BAG” indicator is illuminated.

► Double-cab models



STS12BH006

*1, 2, 3 ①	*4 U
*3 ②	U  
*3 ③	U  



Suitable for “universal” category child restraint system fixed with the seat belt.



Suitable for i-Size and ISOFIX child restraint system.



Includes a top tether anchorage point.



Not suitable for child restraint system.



Never use a rear-facing child restraint system on the front passenger seat when “ON” of the “PASSENGER AIR BAG” indicator is illuminated.

*1: Move the front seat fully rearward. If the passenger seat height can be adjusted, move it to the upper most position.

*2: Adjust the seatback angle to the most upright position.

When installing a forward-facing child seat, if there is a gap between the child seat and the seatback, adjust the seatback angle until good contact is achieved.

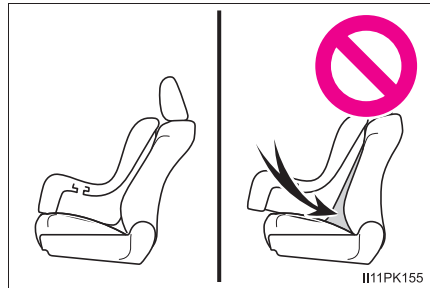

*3: If the head restraint interferes with your child restraint system, and the head restraint can be removed, remove the head restraint. Otherwise, put the head restraint in the upper most position.

*4: Use only a front-facing child restraint system when “ON” of the “PASSENGER AIR BAG” indicator is illuminated.

■ Detail information for child restraint systems installation

▶ Single-cab and smart-cab models

Seating position		
Seat position number	①	
	Vehicles with front passenger occupant classification system	
	“PASSENGER AIR BAG” indicator	
	ON	OFF*
Seating position suitable for universal belted (Yes/No)	Yes Forward facing only	Yes
i-Size seating position (Yes/No)	No	No
Seating position suitable for lateral fixture (L1/L2/No)	No	No
Suitable rearward facing fixture (R1/R2X/R2/R3/No)	No	No
Suitable forward facing fixture (F2X/F2/F3/No)	No	No
Suitable junior seat fixture (B2/B3/No)	No	No

*: When it is unavoidable to install a rear-facing child restraint system on the front passenger seat, a child restraint system can be installed if “OFF” of the “PASSENGER AIR BAG” indicator is illuminated.

ISOFIX child restraint systems are divided into different “fixture”. The child restraint system can be used in the seating positions for “fixture” mentioned in the table above. For kind of “fixture” relation, confirm the following table.

If your child restraint system has no kind of “fixture” (or if you cannot find information in the table below), please refer to the child restraint system “vehicle list” for compatibility information or ask the retailer of your child seat.

Fixture	Description
F3	Full-height, forward-facing child restraint systems
F2	Reduced-height forward-facing child restraint systems
F2X	Reduced-height forward-facing child restraint systems
R3	Full-size, rearward-facing child restraint systems
R2	Reduced-size, rearward-facing child restraint systems
R2X	Reduced-size, rearward-facing child restraint systems
R1	Rearward-facing infant seat
L1	Left lateral-facing (carrycot) infant seat
L2	Right lateral-facing (carrycot) infant seat
B2	Junior seat
B3	Junior seat

- When installing a child seat with support base, if the child seat interferes with the seatback when latching it into the support base, adjust the seatback rearward until there is no interference.
- If the seat belt shoulder anchor is ahead of the child seat belt guide, move the seat cushion forward.

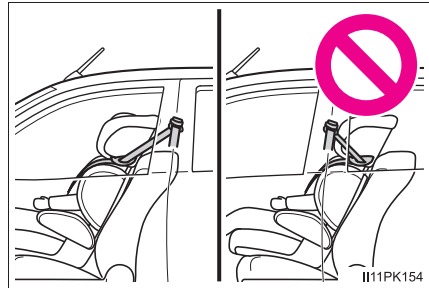

- When installing a junior seat, if the child in your child restraint system is in a very upright position, adjust the seatback angle to the most comfortable position. And if the seat belt shoulder anchor is ahead of the child seat belt guide, move the seat cushion forward.

► Double-cab models

Seating position				
Seat position number	①		②	③
	Vehicles with front passenger occupant classification system			
	“PASSENGER AIR BAG” indicator			
	ON	OFF*		
Seating position suitable for universal belted (Yes/No)	Yes Forward facing only	Yes	Yes	Yes
i-Size seating position (Yes/No)	No	No	Yes	Yes
Seating position suitable for lateral fixture (L1/L2/No)	No	No	No	No
Suitable rearward facing fixture (R1/R2X/R2/R3/No)	No	No	R1, R2X, R2, R3	R1, R2X, R2, R3
Suitable forward facing fixture (F2X/F2/F3/No)	No	No	F2X, F2, F3	F2X, F2, F3
Suitable junior seat fixture (B2/B3/No)	No	No	B2, B3	B2, B3

*: When it is unavoidable to install a rear-facing child restraint system on the front passenger seat, a child restraint system can be installed if “OFF” of the “PASSENGER AIR BAG” indicator is illuminated.

ISOFIX child restraint systems are divided into different “fixture”. The child restraint system can be used in the seating positions for “fixture” mentioned in the table above. For kind of “fixture” relation, confirm the following table.

If your child restraint system has no kind of “fixture” (or if you cannot find information in the table below), please refer to the child restraint system “vehicle list” for compatibility information or ask the retailer of your child seat.

Fixture	Description
F3	Full-height, forward-facing child restraint systems
F2	Reduced-height forward-facing child restraint systems
F2X	Reduced-height forward-facing child restraint systems
R3	Full-size, rearward-facing child restraint systems
R2	Reduced-size, rearward-facing child restraint systems
R2X	Reduced-size, rearward-facing child restraint systems
R1	Rearward-facing infant seat
L1	Left lateral-facing (carrycot) infant seat
L2	Right lateral-facing (carrycot) infant seat
B2	Junior seat
B3	Junior seat

When securing some types of child restraint systems in rear seat, it may not be possible to properly use the seat belts in positions next to the child restraint without interfering with it or affecting seat belt effectiveness. Be sure your seat belt fits snugly across your shoulder and low on your hips. If it does not, or if it interferes with the child restraint, move to a different position.

Failure to do so may result in death or serious injury.

- When installing a child restraint in the rear seats, adjust the front seat so that it does not interfere with the child or child restraint system.
- When installing a child seat with support base in the front seat, if the child seat interferes with the seatback when latching it into the support base, adjust the seatback rearward until there is no interference.
- If the seat belt shoulder anchor is ahead of the child seat belt guide, move the seat cushion forward.

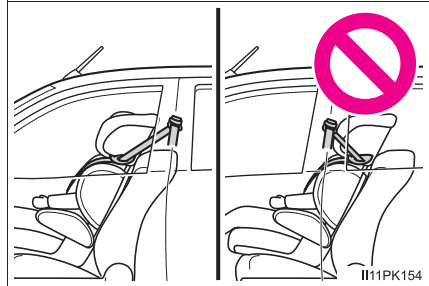

- When installing a junior seat in the front seat, if the child in your child restraint system is in a very upright position, adjust the seatback angle to the most comfortable position. And if the seat belt shoulder anchor is ahead of the child seat belt guide, move the seat cushion forward.

Child restraint system installation method

Confirm with the operation manual enclosed with the child restraint system about the installation of the child restraint system.

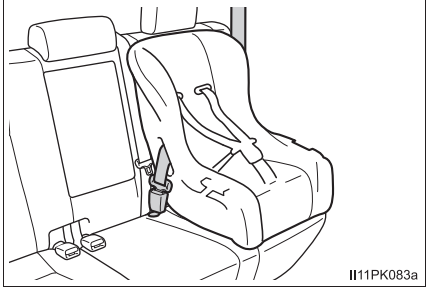
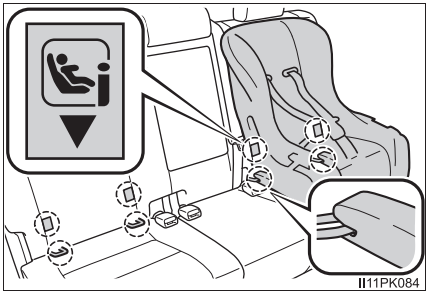
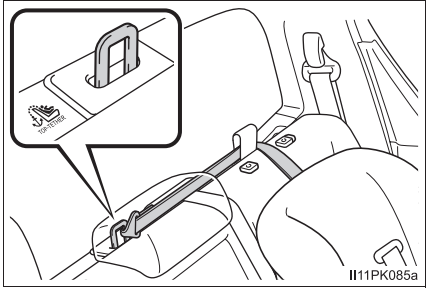
	Installation method	Page
<p>Seat belt attachment</p>		<p>P. 70</p>
<p>ISOFIX rigid anchor attachment</p>		<p>P. 72</p>
<p>Child restraint anchor fitting attachment</p>		<p>P. 74</p>

Child restraint system fixed with a seat belt

■ Installing child restraint system using a seat belt

Install the child restraint system in accordance to the operation manual enclosed with the child restraint system.

If the child restraint system on hand is not within the “universal” category (or the necessary information is not in the table), refer to the “Vehicle List” provided by the child restraint system maker for various possible installation positions, or check the compatibility after asking the retailer of the child restraint system. (→P. 58, 59)

- 1 If installing the child restraint system to the front passenger seat is unavoidable, refer to P. 54 for front passenger seat adjustment.
- 2 Double-cab models: If the head restraint interferes with the child restraint system installation and the head restraint can be removed, remove the head restraint. Otherwise, put the head restraint in the upper most position. (→P. 132)

- 3 Run the seat belt through the child restraint system and insert the plate into the buckle. Make sure that the belt is not twisted. Securely fix the seat belt to the child restraint system in accordance to the directions enclosed with the child restraint system.

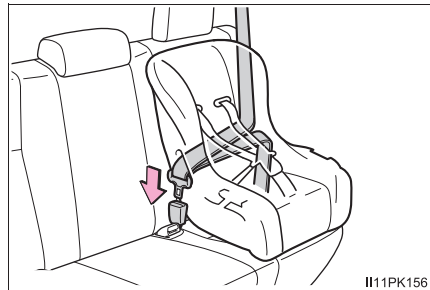

- 4 If your child restraint system is not equipped with a lock-off (a seat belt locking feature), secure the child restraint system using a locking clip.

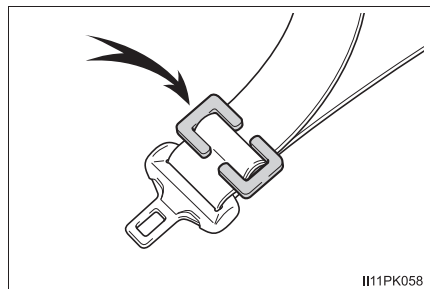

- 5 After installing the child restraint system, rock it back and forth to ensure that it is installed securely. (→P. 71)

■ Removing a child restraint system installed with a seat belt

Press the buckle release button and fully retract the seat belt.

When releasing the buckle, the child restraint system may spring up due to the rebound of the seat cushion. Release the buckle while holding down the child restraint system.

Since the seat belt automatically reels itself, slowly return it to the stowing position.

■ When installing a child restraint system

You may need a locking clip to install the child restraint system. Follow the instructions provided by the manufacturer of the system. If your child restraint system does not provide a locking clip, you can purchase the following item from your Toyota dealer: Locking clip for child restraint system (Part No. 73119-22010)

■ When removing the head restraint to install a child restraint system

After removing the child restraint system, make sure to reinstall the head restraint.

WARNING

■ When installing a child restraint system

Observe the following precautions.

Failure to do so may result in death or serious injury.

- Do not allow children to play with the seat belt. If the seat belt becomes twisted around a child's neck, it may lead to choking or other serious injuries that could result in death. If this occurs and the buckle cannot be unfastened, scissors should be used to cut the belt.
- Ensure that the belt and plate are securely locked and the seat belt is not twisted.
- Shake the child restraint system left and right, and forward and backward to ensure that it has been securely installed.
- After securing a child restraint system, never adjust the seat.
- When a junior seat (booster seat) is installed, always ensure that the shoulder belt is positioned across the center of the child's shoulder. The belt should be kept away from the child's neck, but not so that it could fall off the child's shoulder.
- Follow all installation instructions provided by the child restraint system manufacturer.

Child restraint system fixed with an ISOFIX rigid anchor (if equipped)

■ ISOFIX rigid anchors (ISOFIX child restraint system)

Lower anchors are provided for the outboard rear seats. (Tags displaying the location of the anchors are attached to the seats.)



■ Installation with ISOFIX rigid anchor (ISOFIX child restraint system)

Install the child restraint system in accordance to the operation manual enclosed with the child restraint system.

If the child restraint system on hand is not within the “universal” category (or the necessary information is not in the table), refer to the “Vehicle List” provided by the child restraint system maker for various possible installation positions, or check the compatibility after asking the retailer of the child restraint system. (→P. 58, 59)

- 1 If the head restraint interferes with the child restraint system installation and the head restraint can be removed, remove the head restraint. Otherwise, put the head restraint in the upper most position. (→P. 132)
- 2 Check the positions of the exclusive fixing bars, and install the child restraint system to the seat.

The bars are installed in the clearance between the seat cushion and seatback.



- 3 After installing the child restraint system, rock it back and forth to ensure that it is installed securely. (→P. 71)

■ When removing the head restraint to install a child restraint system

After removing the child restraint system, make sure to reinstall the head restraint.

⚠ WARNING

■ When installing a child restraint system

Observe the following precautions.

Failure to do so may result in death or serious injury.

- After securing a child restraint system, never adjust the seat.
- When using the lower anchors, be sure that there are no foreign objects around the anchors and that the seat belt is not caught behind the child restraint system.
- Follow all installation instructions provided by the child restraint system manufacturer.

■ Using child restraint anchorages

WARNING: child restraint anchorages are designed to withstand only those loads imposed by correctly fitted child restraints. Under no circumstances are they to be used for adult seatbelts, harnesses, or for attaching other items or equipment to the vehicle.

Using a child restraint anchor fitting (if equipped)

■ Child restraint anchor fitting

Anchor fitting is located the center of the rear seat and provided for the outboard rear seat.

Use anchor fitting when fixing the strap.

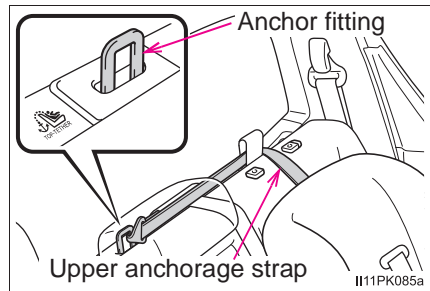

■ Fixing the strap to the anchor fitting

Install the child restraint system in accordance to the operation manual enclosed with the child restraint system.

- 1 Remove the head restraint.

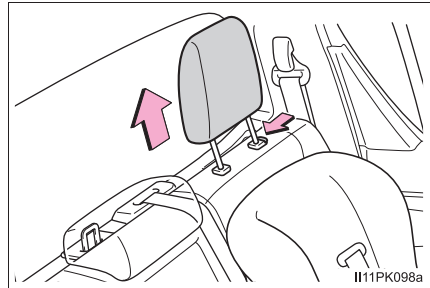

- 2 Pull up the anchor strap router.

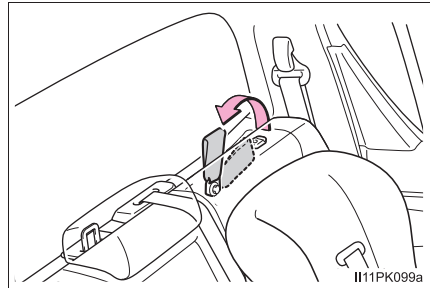

- 3 Route the upper anchorage strap through the anchor strap router as shown in the illustration.

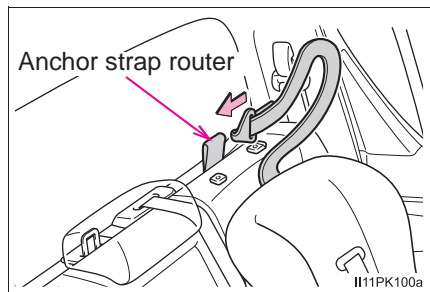

- 4 Latch the attaching clip onto the anchor fitting and tighten the upper anchorage strap.

Make sure the upper anchorage strap is securely latched.
(→P. 71)

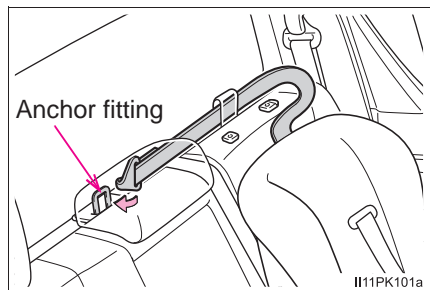

■ When removing the head restraint to install a child restraint system

After removing the child restraint system, make sure to reinstall the head restraint.

⚠ WARNING**■ When installing a child restraint system**

Observe the following precautions.

Failure to do so may result in death or serious injury.

- Firmly attach the top strap.
- Do not attach the upper anchorage strap to anything other than the anchor fitting.
- After securing a child restraint system, never adjust the seat.
- Follow all installation instructions provided by the child restraint system manufacturer.
- When installing the child restraint system, do not install the head restraint.

■ Using child restraint anchorages

WARNING: child restraint anchorages are designed to withstand only those loads imposed by correctly fitted child restraints. Under no circumstances are they to be used for adult seatbelts, harnesses, or for attaching other items or equipment to the vehicle.

Engine immobilizer system

The vehicle's keys have built-in transponder chips that prevent the engine from starting if a key has not been previously registered in the vehicle's on-board computer.

Never leave the keys inside the vehicle when you leave the vehicle.

This system is designed to help prevent vehicle theft but does not guarantee absolute security against all vehicle thefts.

Vehicles without smart entry & start system:

The indicator light flashes after the key has been removed from the engine switch to indicate that the system is operating.

The indicator light stops flashing after the registered key has been inserted into the engine switch to indicate that the system has been canceled.

Vehicles with smart entry & start system:

The indicator light flashes after the engine switch has been turned off to indicate that the system is operating.

The indicator light stops flashing after the engine switch has been turned to ACCESSORY or IGNITION ON mode to indicate that the system has been canceled.

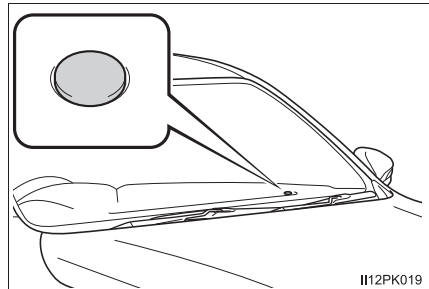

■ System maintenance

The vehicle has a maintenance-free type engine immobilizer system.

■ Conditions that may cause the system to malfunction

- If the grip portion of the key is in contact with a metallic object
- If the key is in close proximity to or touching a key to the security system (key with a built-in transponder chip) of another vehicle

**NOTICE****■ To ensure the system operates correctly**

Do not modify or remove the system. If modified or removed, the proper operation of the system cannot be guaranteed.

Alarm

The alarm

The alarm uses light and sound to give an alert when an intrusion is detected.

The alarm is triggered in the following situations when the alarm is set:

- A locked door is opened in any way other than using the entry function (vehicles with smart entry & start system), wireless remote control or mechanical key.
- The hood is opened.

Setting the alarm system

Close the doors and hood, and lock all the doors. The system will be set automatically after 30 seconds.

The indicator light changes from being on to flashing when the system is set.

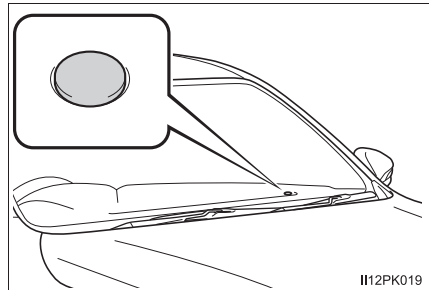

Deactivating or stopping the alarm

Do one of the following to deactivate or stop the alarms:

- Unlock the doors.
- Start the engine. (The alarm will be deactivated or stopped after a few seconds.)

■ System maintenance

The vehicle has a maintenance-free type alarm system.

■ Items to check before locking the vehicle

To prevent unexpected triggering of the alarm and vehicle theft, make sure of the following:

- Nobody is in the vehicle.
- The windows are closed before the alarm is set.
- No valuables or other personal items are left in the vehicle.

■ Triggering of the alarm

The alarm may be triggered in the following situation:
(Stopping the alarm deactivates the alarm system.)

A person inside the vehicle opens a door or hood.



⚠ NOTICE

■ To ensure the system operates correctly

Do not modify or remove the system. If modified or removed, the proper operation of the system cannot be guaranteed.

2. Instrument cluster

Warning lights and indicators	82
Gauges and meters	89
Multi-information display	92
Fuel consumption information	101

Warning lights and indicators

The warning lights and indicators on the instrument cluster and center panel inform the driver of the status of the vehicle's various systems.

For the purpose of explanation, the following illustration displays all warning lights and indicators illuminated.

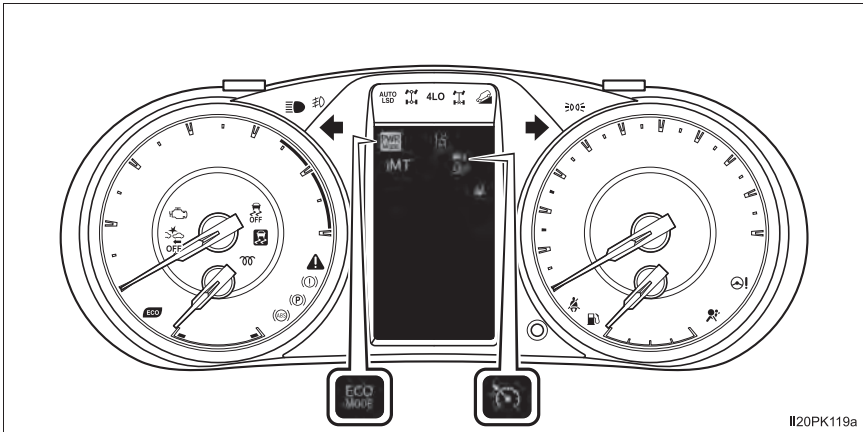

Warning lights

Warning lights inform the driver of malfunctions in the indicated vehicle's systems.



Brake system warning light (→P. 421)

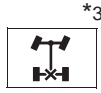

(Flashes)
(If equipped)

Rear differential lock indicator light (→P. 422)

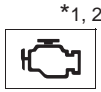

(Flashes or illuminates)

Malfunction indicator lamp (→P. 421)



(Flashes or illuminates)

PCS warning light (→P. 423)



SRS warning light (→P. 421)



(Yellow)

LDA indicator (→P. 423)



ABS warning light (→P. 422)



(Flashes or illuminates)

Driver's and front passenger's seat belt reminder light (→P. 423)



(if equipped)

Power steering system warning light (→P. 422)

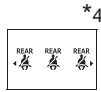

(Flashes or illuminates)
(If equipped)

Rear passengers' seat belt reminder lights (→P. 423)



Slip indicator (→P. 422)

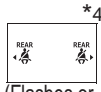

(Flashes or illuminates)
(If equipped)



(Flashes)
(If equipped)

Low speed four-wheel drive indicator light (→P. 422)



Low fuel level warning light (→P. 423)



Master warning light
(→P. 423)

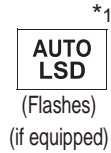

“AUTO LSD” indicator
(→P. 424)



Parking brake indicator
light (→P. 424)

- *1: These lights turn on when the engine switch is turned to the “ON” position (vehicles without smart entry & start system) or IGNITION ON mode (vehicles with smart entry & start system) to indicate that a system check is being performed. They will turn off after the engine is started, or after a few seconds. There may be a malfunction in a system if a light does not come on, or if the lights do not turn off. Have the vehicle inspected by your Toyota dealer.
- *2: The light turns on or flashes to indicate a malfunction.
- *3: The light flashes rapidly to indicate a malfunction.
- *4: The lights illuminate on the center panel.

Indicators

The indicators inform the driver of the operating state of the vehicle's various systems.



Turn signal indicator
(→P. 198)



Headlight high beam indicator (→P. 201)



Tail light indicator
(→P. 200)



(if equipped)

Fog light indicator
(→P. 204)



*1

Eco Driving Indicator Light (→P. 87)



(diesel engine)

Engine preheating indicator (→P. 173, 176)



Cruise control indicator
(→P. 246)



Dynamic radar cruise control indicator
(→P. 246)



Cruise control "SET" indicator (→P. 246)



(if equipped)

Downhill assist control system indicator
(→P. 291)



*1, 2

Slip indicator (→P. 285)



*1, 3

VSC OFF indicator
(→P. 286)



(4WD models)

Four-wheel drive indicator light (→P. 270)



(4WD models)

Low speed four-wheel drive indicator light
(→P. 270)



(if equipped)

Rear differential lock indicator light (→P. 280)



(if equipped)

"ECO MODE" indicator
(→P. 186, 192)



(if equipped)

"PWR MODE" indicator
(→P. 186, 192)



(if equipped)

"iMT" indicator (→P. 193)



*1, 3

PCS warning light
(→P. 220)



*4

LDA indicator (→P. 237)



Low outside temperature indicator
(→P. 89)

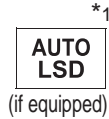

"AUTO LSD" indicator
(→P. 294)



Parking brake indicator light (→P. 199)



"PASSENGER AIR BAG" indicator
(→P. 46)

- *1: These lights turn on when the engine switch is turned to the "ON" position (vehicles without smart entry & start system) or IGNITION ON mode (vehicles with smart entry & start system) to indicate that a system check is being performed. They will turn off after the engine is started, or after a few seconds. There may be a malfunction in a system if a light does not come on, or if the lights do not turn off. Have the vehicle inspected by your Toyota dealer.
- *2: The light flashes to indicate that the system is operating.
- *3: The light turns on when the system is turned off.
- *4: Depending on the operating condition, the color and illuminating/flashing state of the light change.
- *5: The light illuminates on the center panel.

■ Eco Driving Indicator

① Eco Driving Indicator Light

Vehicles with automatic transmission: During Eco-friendly acceleration (Eco driving), Eco Driving Indicator Light will turn on. When the accelerator pedal is depressed excessively, or when the vehicle is stopped, the light turns off.

Vehicles with manual transmission: During Eco-friendly acceleration or in Eco-friendly shift position (Eco driving), Eco Driving Indicator Light will turn on. When the accelerator pedal is depressed excessively, or when the vehicle is stopped, the light turns off.

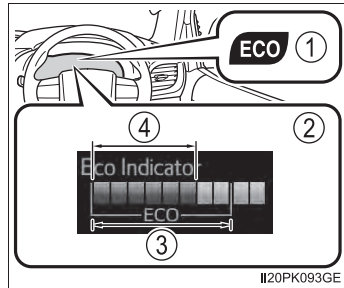

② Eco Driving Indicator Zone Display

Suggests Zone of Eco driving with current Eco driving ratio based on acceleration.

③ Zone of Eco driving

④ Eco driving ratio based on acceleration

If the vehicle exceeds Zone of Eco driving, the right side of Eco Driving Indicator Zone Display will illuminate.

Eco Driving Indicator Light and Eco Driving Indicator Zone Display will not operate in the following conditions:

- The shift lever is in anything other than D. (vehicles with automatic transmission)
- The shift lever is in R. (vehicles with manual transmission)
- The vehicle is in the power mode. (if equipped) (→P. 186, 192)
- Downhill assist control system is operating. (if equipped) (→P. 291)
- Front-wheel drive control switch is in L4. (if equipped) (→P. 270)
- The vehicle speed is approximately 130 km/h (81 mph) or higher.

Eco Driving Indicator Light can be activated or deactivated.

→P. 484

**WARNING****■ If a safety system warning light does not come on**

Should a safety system light such as ABS and the SRS warning light not come on when you start the engine, this could mean that these systems are not available to help protect you in an accident, which could result in death or serious injury. Have the vehicle inspected by your Toyota dealer immediately if this occurs.

Gauges and meters

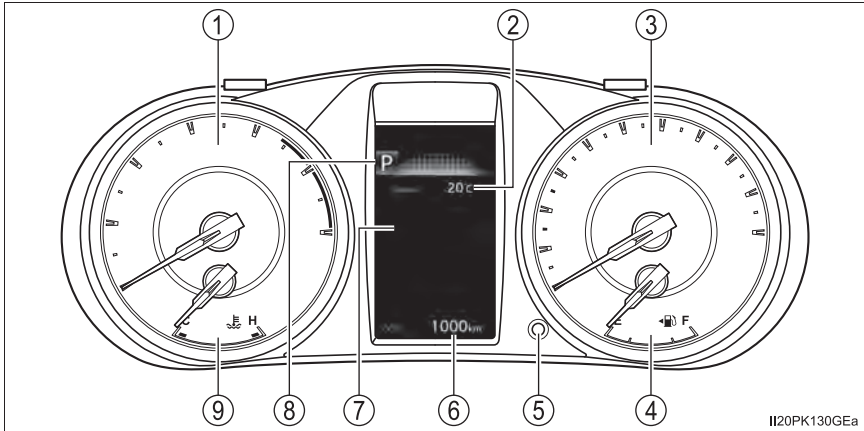

① Tachometer

Displays the engine speed in revolutions per minute.

② Outside temperature

Displays the outside temperature. The temperature range that can be displayed is from -40°C (-40°F) to 50°C (122°F). The low outside temperature indicator comes on when the ambient temperature is approximately 3°C (37°F) or lower, and goes off when approximately 5°C (41°F) or higher. (→P. 86)

③ Speedometer

Displays the vehicle speed.

④ Fuel gauge

Displays the quantity of fuel remaining in the tank.

⑤ Odometer/trip meter display change button

→P. 90

⑥ Odometer and trip meter

Odometer:

Displays the total distance the vehicle has been driven.

Trip meter:

Displays the distance the vehicle has been driven since the meter was last reset. Trip meters A and B can be used to record and display different distances independently.

⑦ Multi-information display

Presents the driver with a variety of driving-related data. (→P. 92)

- ⑧ Shift position and shift range (automatic transmission)
Displays the selected shift position or selected shift range. (→P. 184)
- ⑨ Engine coolant temperature gauge
Displays the engine coolant temperature.

Changing the display

Pressing this button switches among odometer, trip meter and instrument panel light control displays.

- ① Odometer
- ② Trip meter A*¹
- ③ Trip meter B*¹
- ④ Instrument panel light control display*²

*1: Pressing and holding the button will reset the trip meter.

*2: Pressing and holding the button will adjust brightness of the instrument panel lights.

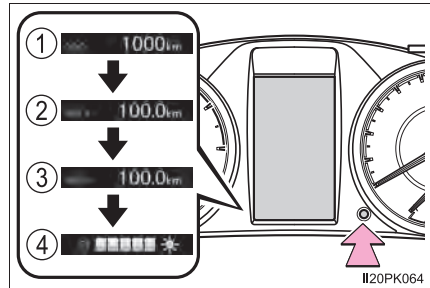

■ The meters illuminate when

The engine switch is in the "ON" position (vehicles without smart entry & start system) or IGNITION ON mode (vehicles with smart entry & start system).

■ The brightness of the instrument panel lights

The instrument panel brightness levels when the tail lights are on and off can be adjusted individually.

When the headlight switch is turned on, the brightness will be reduced slightly unless the instrument panel brightness level is set to the brightest setting.

■ When disconnecting and reconnecting battery terminals

The trip meter data will be reset.

■ Outside temperature display

In the following situations, the correct outside temperature may not be displayed, or the display may take longer than normal to change:

- When the vehicle is stopped, or moving at low speeds (less than 25 km/h [15 mph])
- When the outside temperature has changed suddenly (at the entrance/exit of a garage, tunnel, etc.)

■ When "--" is displayed

The system may be malfunctioning. Take your vehicle to your Toyota dealer.



WARNING

■ The information display at low temperatures

Allow the interior of the vehicle to warm up before using the liquid crystal information display. At extremely low temperatures, the display monitor may respond slowly, and display changes may be delayed.

For vehicles with automatic transmission: For example, there is a lag between the driver's shifting and the new gear number appearing on the display. This lag could cause the driver to downshift again, causing rapid and excessive engine braking and possibly an accident resulting in death or injury.



NOTICE

■ To prevent damage to the engine and its components

- Do not let the indicator needle of the tachometer enter the red zone, which indicates the maximum engine speed.
- The engine may be overheating if the engine coolant temperature gauge is in the red zone (H). In this case, immediately stop the vehicle in a safe place, and check the engine after it has cooled completely. (→P. 459)

Multi-information display

Display contents

The multi-information display presents the driver with a variety of vehicle data.

The following information will be displayed when a menu icon is selected.

Menu icons are displayed for a few seconds when the meter control switches (→P. 93) are operated.

On the area, normally the outside temperature is displayed.

(→P. 89)

Some of the information may be displayed automatically depending on the situation.

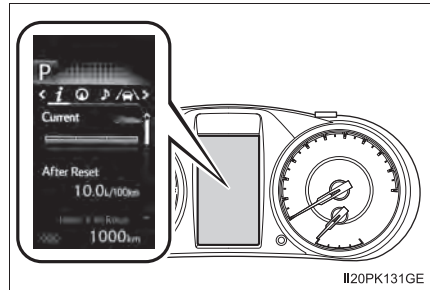

Drive information

Select to display various drive data. (→P. 94)



Navigation system-linked display (if equipped)

Select to display the following navigation system-linked information.

- Route guidance
- Compass display



Audio system-linked display

Select to enable selection of an audio source or track on the meter using the meter control switches.



Driving support system information

Select to display the operational status of the following systems:

- LDA (Lane Departure Alert With Yaw Assist Function) (→P. 231)
- RSA (Road Sign Assist) (→P. 242)
- Dynamic radar cruise control (→P. 246)



Warning message display

Select to display warning messages and measures to be taken if a malfunction is detected. (→P. 426)



Settings display

Select to change the meter display settings. (→P. 484)

Operating the meter control switches

The multi-information display is operated using the meter control switches.

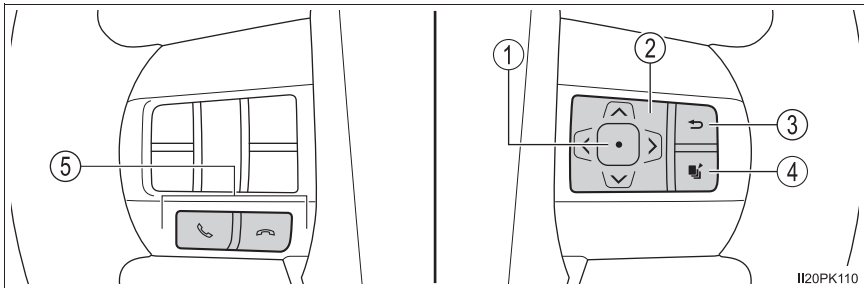

- ① Enter/Set
- ② Select an item/Change pages
- ③ Return to the previous screen
- ④ Press: Displays the screen registered as the top screen

When no screen has been registered, the drive information screen will be displayed.

Press and hold: Registers the currently displayed screen as the top screen

When the confirmation screen is displayed, select yes to register the screen. If the selected screen cannot be registered, a registration failure message will be shown.

- ⑤ Incoming call display (if equipped)

Linked with the hands-free system, incoming call is displayed. For details regarding the hands-free system, refer to "Navigation and Multimedia System Owner's Manual" or "Multimedia Owner's Manual".

Drive information

Items displayed can be switched by pressing “<” or “>” of the meter control switches to select  and pressing “^” or “v”.

■ Drive information 1 and 2

- Current fuel economy (bar type/value type)*1, 2

Displays the current rate of fuel consumption.

- Average fuel economy (after reset*3/after start/after refuel)*1, 2

Displays the average fuel consumption since the function was reset, the engine was started and the vehicle was refueled respectively.

- Average speed (after reset*3/after start)*1

Displays the average vehicle speed since function was reset and the engine was started respectively.

- Elapsed time (after reset*3/after start)*1

Displays the elapsed time since the function was reset and the engine was started respectively.

- Distance (range/after start)*1

Displays the estimated maximum distance that can be driven with the quantity of fuel remaining.

- This distance is computed based on your average fuel consumption. As a result, the actual distance that can be driven may differ from that displayed.
- When only a small amount of fuel is added to the tank, the display may not be updated.

When refueling, turn the engine switch off. If the vehicle is refueled without turning the engine switch off, the display may not be updated.

*1: Can be registered to drive information 1 and 2. (→P. 96)

*2: Use the displayed fuel consumption as a reference.

*3: Resetting procedures:

- Select a function to be reset using the meter control switches and then press and hold  to reset.
- If there is more than one function that can be reset, check boxes will be displayed next to those functions.

■ Eco Driving Indicator Zone Display

Displays Zone of Eco driving with current Eco driving ratio based on acceleration. (→P. 87)

■ Eco Score

Displays the eco-driving total count to help improve the customer's eco driving techniques. (→P. 98)

■ Eco Saving

Displays the fuel consumption comparison, the average fuel consumption after reset, and the cost of the consumed fuel. (→P. 99)

■ Speedometer display

Displays the vehicle speed.

■ Steering angle

Displays the direction of the front tires.

The tire direction is displayed in 3 stages for both left and right, in accordance with the angle of the tire.

While Toyota parking assist-sensor (→P. 262) is operating (if equipped) or any door is not fully closed, the related information is displayed with the direction of the front tires.

If a battery terminal is disconnected and reconnected, the display may be disabled temporarily. After driving the vehicle for a while, the display will be enabled.

Settings display

The settings of the following items can be changed, refer to P. 483

■ LDA (Lane Departure Alert With Yaw Assist Function) (→P. 231)

Select to set up the following items.

- Yaw Assist

Select to enable/disable yaw assist function.

- Warning Sensitivity

Select to set the warning sensitivity.

- Sway Warning Function

Select to enable/disable the vehicle sway warning.

- Sway Warning Sensitivity

Select to set the vehicle sway warning sensitivity.

■ PCS (Pre-Collision System) (→P. 220)

Select to set up the following items.

- PCS On/Off

Select to enable/disable the pre-collision system.

- Sensitivity (adjust alert timing)

Select to change the pre-collision warning timing.

■ RSA (Road Sign Assist) (→P. 242)

Select to set up the following items.

- Road Sign Assist On/Off

Select to enable/disable the RSA system.

- Notification Method (excess speed)

Select to change each notification method used to warn the driver when the system recognizes excess speed.

- Notification Level

Select to change each notification level used to warn the driver when the system recognizes a speed limit sign.

■ DRCC(RSA) (→P. 257)

Select to enable/disable the Dynamic Radar Cruise Control with Road Sign Assist.

■ Meter Customization

● Units

Select to change the unit for measure of the fuel consumption.

● Eco Driving Indicator Light

Select to activate/deactivate the Eco Driving Indicator Light.
(→P. 87)

● switch settings

You can register 1 screen as the top screen. To register, press and hold  while the desired screen is displayed.

● Drive information 1 and 2

Select to select up to 2 items that will be displayed on a drive information screen, up to 2 drive information screens can be set.

● Pop-up display

Select to set the following pop-up displays, which may appear in some situations, on/off.

- Route guidance display of the navigation system-linked system (if equipped)
- Incoming call display of the hands-free phone system (if equipped)

● Accent color

Select to change the accent colors on the screen, such as the cursor color.

● Eco Saving

Select to set or change the fuel consumption comparison and fuel price. (→P. 99)

● Initialization

Registered or changed meter settings will be deleted or returned to their default setting.

■ Pop-up display

In some situations, such as when a switch operation is performed, a pop-up display will be temporarily displayed on the multi-information display.

The pop-up display function can be set on/off. (→P. 484)

■ Eco Score

Driving conditions are displayed in 5 stages and divided into 3 categories: start, cruise and stop. Every time the vehicle is stopped, the score is displayed. (Every time the vehicle is accelerated the score that was last displayed is reset. Accumulative scores are not calculated.)

① Eco Score

Totals the counts of the eco start, eco cruise and eco stop, and displays the result.

② Eco start

Displays the eco level calculated from degree of acceleration when starting the vehicle

③ Eco cruise

Displays the eco level calculated from acceleration operation amount when driving the vehicle

④ Eco stop

Displays the eco level calculated from time between releasing the accelerator pedal and vehicle stop

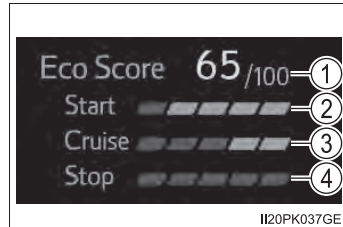

If the accelerator pedal is not depressed, such as when the vehicle is driven using dynamic radar cruise control, the driven distance is not included in the Eco Score.

The Eco Score evaluation differs depending on the driving conditions and environmental factors. The Eco Score may not be linked to fuel consumption. The Eco Score will not operate in the following conditions:

- The vehicle speed is approximately 130 km/h (80 mph) or higher.
- The shift lever is in a position other than D. (vehicles with automatic transmission)
- Front-wheel drive control switch is in L4. (if equipped)
- Downhill assist control system is operating. (if equipped)
- The vehicle is in the power mode. (if equipped)

■ Eco Saving

Displays the fuel consumption comparison, the average fuel consumption after reset, and the cost of the consumed fuel.

① Fuel consumption comparison

Displays the set fuel consumption that is compared with the actual fuel consumption.

② Average fuel consumption after reset

Displays the average fuel consumption since the function was reset.

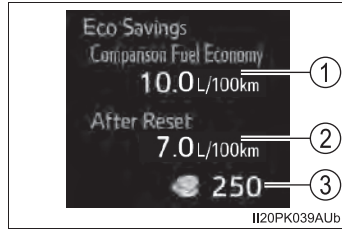



- The function can be reset by pressing  more than 1 second when the average fuel consumption after reset is displayed
- Use the average fuel consumption as a reference

③ Savings/fuel cost

Displays the possible savings if the fuel consumption comparison is set, and displays the actual fuel cost if the fuel consumption comparison is not set.

Use the displayed fuel cost and savings as a reference. Depending on refueling methods, driving conditions and environmental factors, the displayed fuel cost may differ from the actual fuel cost, and in some cases, the fuel cost and savings may not be linked to the Eco Score evaluation.

■ Eco Saving setting

The fuel price and fuel consumption comparison settings can be set in the settings display. Use the meter control switches to select  while the vehicle is stopped and press , and select "Eco Saving" and press .

■ Setting display automatic cancelation

In the following situations, setting display in which the settings can be changed through the meter control switches will automatically be turned off.

- If a warning message appears while the setting display is displayed
- When the vehicle begins to move while the setting display is displayed

■ When disconnecting and reconnecting battery terminals

The drive information data and settings will be reset.

■ Liquid crystal display

Small spots or light spots may appear on the display. This phenomenon is characteristic of liquid crystal displays, and there is no problem continuing to use the display.

**WARNING****■ Caution for use while driving**

- When operating the multi-information display while driving, pay extra attention to the safety of the area around the vehicle.
- Do not look continuously at the multi-information display while driving as you may fail to see pedestrians, objects on the road, etc. ahead of the vehicle.

■ Eco Score

Use the Eco Score as a reference. Always drive safely in accordance with road and traffic conditions.

Fuel consumption information

The fuel consumption information can be displayed on the navigation system or multimedia system screen.

- ① Navigation system or multimedia system screen
- ② “MENU” button
- ③ “INFO” button (if equipped)

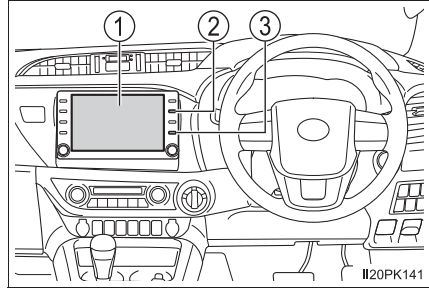

Displaying trip information or history screen

- ▶ When using “INFO” button

Press the “INFO” button.

- ▶ When using “MENU” button

- 1 Press the “MENU” button.
- 2 Select “Information” on the “Menu” screen.
- 3 Select “ECO” on the “Information” screen. (if equipped)

Fuel consumption

■ Trip information

If the trip information screen does not appear, select “Trip Information”.

- ① Fuel consumption in the past 15 minutes
- ② Current fuel consumption
- ③ Reset the trip information data
- ④ “History” screen appears
- ⑤ Cruising range
- ⑥ Elapsed time since the engine was started
- ⑦ Average vehicle speed since the engine was started

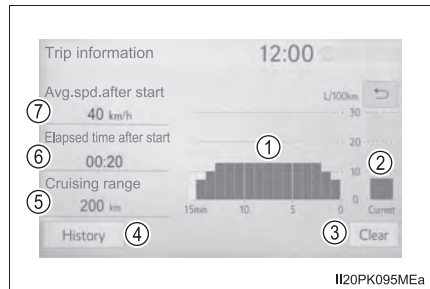

Average fuel consumption for the past 15 minutes is divided by color into past averages and averages attained since the engine switch was last turned to the “ON” position (vehicles without smart entry & start system) or IGNITION ON mode (vehicles with smart entry & start system). Use the displayed average fuel consumption as a reference.

These images are examples only, and may vary slightly from actual conditions.

■ History

If the history screen does not appear, select “History”.

- ① Best recorded fuel consumption
- ② Latest fuel consumption
- ③ Previous fuel consumption record
- ④ Reset the history data
- ⑤ Update the latest fuel consumption data
- ⑥ “Trip Information” screen appears

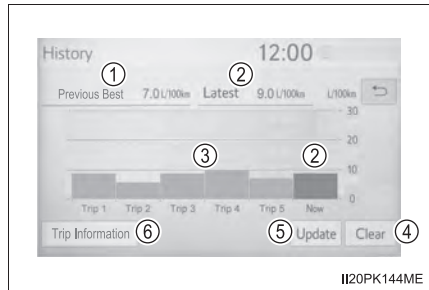

The average fuel consumption history is divided by color into past averages and the average fuel consumption since the last updated. Use the displayed average fuel consumption as a reference.

These images are examples only, and may vary slightly from actual conditions.

■ Updating the history data

Update the latest fuel consumption by selecting “Update” to measure the current fuel consumption again.

■ Resetting the data

The fuel consumption data can be deleted by selecting “Clear”.

■ Cruising range

Displays the estimated maximum distance that can be driven with the quantity of fuel remaining.

This distance is computed based on your average fuel consumption. As a result, the actual distance that can be driven may differ from that displayed.

3-1. Key information	
Keys.....	106
3-2. Opening, closing and locking the doors	
Side doors.....	111
Access panels (smart-cab models only)	116
Tailgate	117
Smart entry & start system	120
3-3. Adjusting the seats	
Front seats.....	127
Rear seats	129
Head restraints	132
3-4. Adjusting the steering wheel and mirrors	
Steering wheel	135
Inside rear view mirror	137
Outside rear view mirrors	139
3-5. Opening and closing the windows	
Power windows.....	142
Quarter windows (smart-cab models).....	146

Keys

The keys

The following keys are provided with the vehicle.

▶ Type A

① Master keys

Operating the wireless remote control function (→P. 107)

② Valet key

③ Key number plate

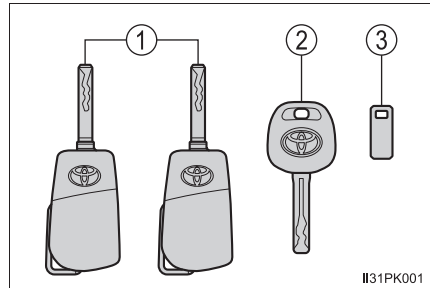

II31PK001

▶ Type B (vehicles with smart entry & start system)

① Electronic keys

- Operating the smart entry & start system (→P. 120)
- Operating the wireless remote control function (→P. 107)

② Mechanical keys

③ Key number plate

④ Mechanical keys (supplementary keys)

Locking and unlocking the tailgate (→P. 117)

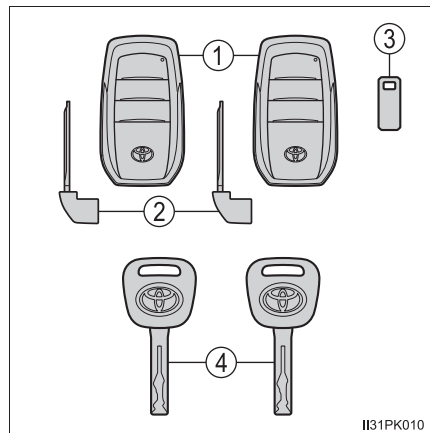

II31PK010

▶ Type C (vehicles with smart entry & start system)

① Electronic keys

- Operating the smart entry & start system (→P. 120)
- Operating the wireless remote control function (→P. 107)

② Mechanical keys

③ Key number plates

④ Fuel tank cap keys

Locking and unlocking the fuel tank cap (→P. 208)



Wireless remote control

▶ Vehicles without smart entry & start system

① Locks all the doors (→P. 111)

Check that the door is securely locked.

② Unlocks all the doors (→P. 111)

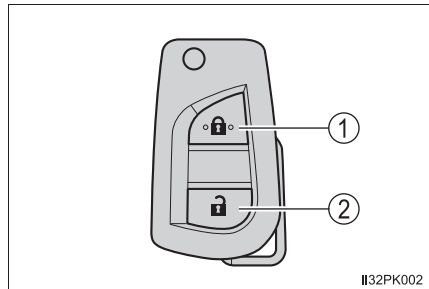

▶ Vehicles with smart entry & start system

① Locks all the doors (→P. 111)

Check that the door is securely locked.

② Unlocks all the doors (→P. 111)

③ Sounds the alarm (→P. 108)

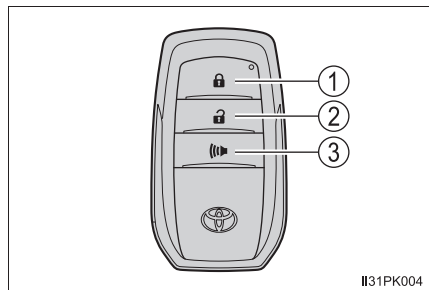

Using the master key (vehicles without smart entry & start system)

① Releasing

To release the key, press the button.

② Folding

To stow the key back in its case, push the key back to the stowed position while pressing the button.

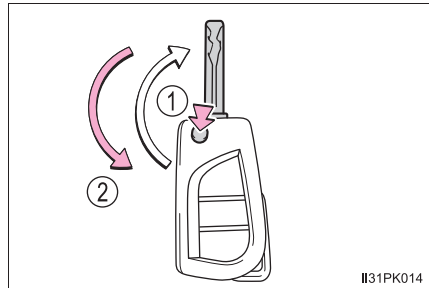

Using the mechanical key (vehicles with smart entry & start system)

To take out the mechanical key, slide the release lever and take the key out.

The mechanical key can only be inserted in one direction, as the key only has grooves on one side. If the key cannot be inserted in a lock cylinder, turn it over and re-attempt to insert it.

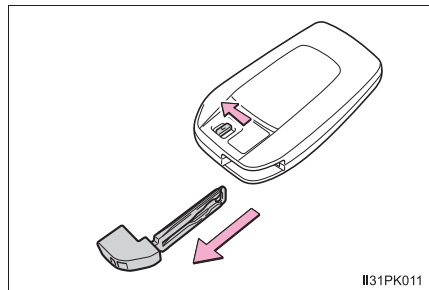

After using the mechanical key, store it in the electronic key. Carry the mechanical key together with the electronic key. If the electronic key battery is depleted or the entry function does not operate properly, you will need the mechanical key. (→P. 450)

■ Panic mode (vehicles with smart entry & start system)

When  is pressed for longer than about one second, an alarm will sound intermittently and the vehicle lights will flash to deter any person from trying to break into or damage your vehicle.

To stop the alarm, press any button on the electronic key.



■ When required to leave the vehicle's key with a parking attendant

Lock the glove box as circumstances demand. (→P. 324)

▶ Vehicles without smart entry & start system

Carry the master key for your own use and provide the attendant with the valet key.

▶ Vehicles with smart entry & start system

Remove the mechanical key for your own use and provide the attendant with the electronic key only. If there is the supplementary key, carry the supplementary key for your own use as well as the mechanical key.

■ If you lose your keys

New genuine keys can be made by your Toyota dealer using a master key (vehicles without smart entry & start system) or the other key of the same type (vehicles with smart entry & start system), and the key number stamped on your key number plate. Keep the plate in a safe place such as your wallet, not in the vehicle.

■ When riding in an aircraft

When bringing a key with wireless remote control function onto an aircraft, make sure you do not press any buttons on the key while inside the aircraft cabin. If you are carrying the key in your bag etc., ensure that the buttons are not likely to be pressed accidentally. Pressing a button may cause the key to emit radio waves that could interfere with the operation of the aircraft.

■ Key battery depletion

▶ Vehicles without smart entry & start system

If the wireless remote control function does not operate, the battery may be depleted. Replace the battery when necessary. (→P. 373)

▶ Vehicles with smart entry & start system

→P. 125

■ If a message regarding the state of the electronic key or engine switch mode, etc. is shown

To prevent trapping the electronic key inside the vehicle, leaving the vehicle without turning off the engine switch or other passengers from unintentionally taking the key out of the vehicle, etc., a message that prompts the user to confirm the state of the electronic key or engine switch mode may be shown on the multi-information display. In those cases, follow the instructions on the display immediately.

■ If "Key battery low" is shown on the multi-information display

The electronic key has a low battery. Replace the electronic key battery.

■ Replacing the electronic key battery

→P. 373

■ Confirmation of the registered key number

The number of keys already registered to the vehicle can be confirmed. Ask your Toyota dealer for details.

**NOTICE****■ To prevent key damage**

- Do not drop the keys, subject them to strong shocks or bend them.
- Do not expose the keys to high temperatures for long periods of time.
- Do not get the keys wet or wash them in an ultrasonic washer etc.
- Do not attach metallic or magnetic materials to the keys or place the keys close to such materials.
- Do not disassemble the keys.
- Do not attach a sticker or anything else to the surface of the electronic key.
- Do not place the keys near objects that produce magnetic fields, such as TVs, audio systems and induction cookers, or medical electrical equipment, such as low-frequency therapy equipment.

■ Carrying the electronic key on your person (vehicles with smart entry & start system)

Carry the electronic key 10 cm (3.9 in.) or more away from electric appliances that are turned on. Radio waves emitted from electric appliances within 10 cm (3.9 in.) of the electronic key may interfere with the key, causing the key to not function properly.

■ In case of a smart entry & start system malfunction or other key-related problems (vehicles with smart entry & start system)

Take your vehicle with all the electronic keys provided with your vehicle to your Toyota dealer.

■ When an electronic key is lost (vehicles with smart entry & start system)

If the electronic key remains lost, the risk of vehicle theft increases significantly. Visit your Toyota dealer immediately with all remaining electronic keys that were provided with your vehicle.

Side doors

The vehicle can be locked and unlocked using the entry function, wireless remote control, key or door lock switch.

Locking and unlocking the doors from outside

◆ Smart entry & start system (if equipped)

While carrying the electronic key, press the button to lock and unlock.

After locking, check that the door is securely locked.

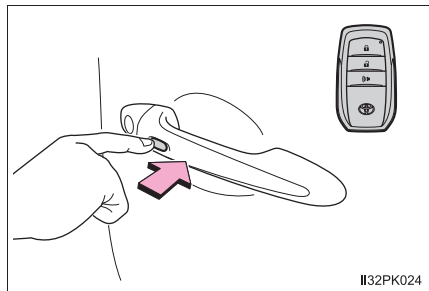

◆ Wireless remote control

▶ Vehicles without smart entry & start system

▶ Vehicles with smart entry & start system

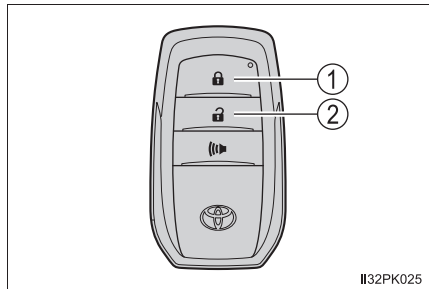
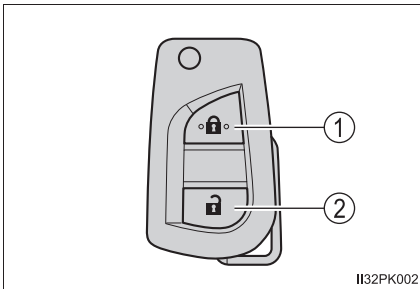

① Locks all the doors

Check that the door is securely locked.

② Unlocks all the doors

◆ Key

▶ Vehicles without smart entry & start system

- ① Locks all the doors
- ② Unlocks all the doors

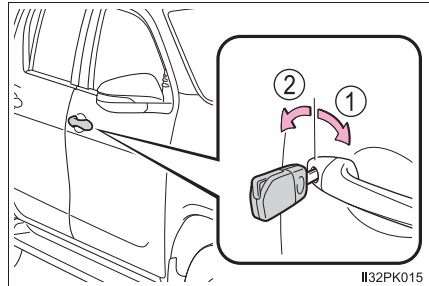

▶ Vehicles with smart entry & start system

The doors can also be locked and unlocked with the mechanical key. (→P. 450)

■ Operation signals

A buzzer* sounds and the emergency flashers flash to indicate that the doors have been locked/unlocked using the smart entry & start system or the wireless remote control. (Locked: once; Unlocked: twice)

*: Vehicles with smart entry & start system

■ Security feature

If a door is not opened within approximately 30 seconds after the vehicle is unlocked using the smart entry & start system or the wireless remote control, the security feature automatically locks the vehicle again.

■ Door lock buzzer

If an attempt to lock the doors is made when a door is not fully closed, a buzzer sounds continuously for 5 seconds. Fully close the door to stop the buzzer, and lock the vehicle once more.

■ If the entry function (vehicles with smart entry & start system) or the wireless remote control does not operate properly

- Vehicles without smart entry & start system: Use the key to lock and unlock the doors. (→P. 112)
- Vehicles with smart entry & start system: Use the mechanical key to lock and unlock the doors. (→P. 450)
- Replace the battery with a new one if it is depleted. (→P. 373)

■ Setting the alarm

Locking the doors will set the alarm system. (→P. 79)

■ If a symbol indicating one or more doors are open is shown on the multi-information display

One or more of the doors is not fully closed. The system also indicates which doors are not fully closed. If the vehicle reaches a speed of 5 km/h (3 mph), master warning light flashes and a buzzer sounds to indicate that the door(s) are not yet fully closed.

Make sure that all the doors are closed.

Locking and unlocking the doors from inside

◆ Door lock switch

- ① Locks all the doors
- ② Unlocks all the doors

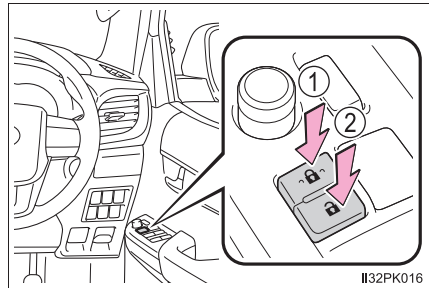

◆ Inside lock button

- ① Locks the door
- ② Unlocks the door

The driver's door can be opened by pulling the inside handle even if the lock button is in the lock position.

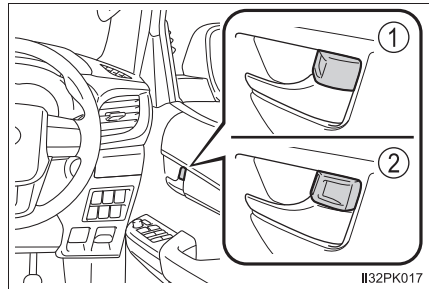

Locking the front doors from the outside without a key

- 1 Move the inside lock button to the lock position.
- 2 Close the door while pulling the door handle.

Vehicles without smart entry & start system: The driver's door cannot be locked if either of the door is open and the key is in the engine switch.

Vehicles with smart entry & start system: The door cannot be locked if the engine switch is in ACCESSORY or IGNITION ON mode, or the electronic key is left inside the vehicle.

However, the key may not be detected correctly and the door may be locked.

Rear door child-protector lock (double-cab models only)

The door cannot be opened from inside the vehicle when the lock is set.

- 1 Unlock
- 2 Lock

These locks can be set to prevent children from opening the rear doors. Push down on each rear door switch to lock both rear doors.

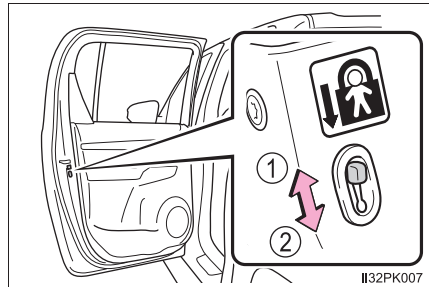

■ Conditions affecting operation

- ▶ Vehicles without smart entry & start system

The wireless remote control function may not operate normally in the following situations:

- Near a TV tower, radio station, electric power plant, airport or other facility that generates strong radio waves
 - When carrying a portable radio, cellular phone or other wireless communication device
 - When multiple wireless keys are in the vicinity
 - When the wireless key is in contact with, or is covered by a metallic object
 - When a wireless key (that emits radio waves) is being used nearby
 - When the wireless key has been left near an electrical appliance such as a personal computer
- ▶ Vehicles with smart entry & start system

→P. 123

**WARNING****■ To prevent an accident**

Observe the following precautions while driving the vehicle.

Failing to do so may result in a door opening and an occupant falling out, resulting in death or serious injury.

- Ensure that all doors are properly closed and locked.
- Do not pull the inside handle of the doors while driving.
Be especially careful for the driver's door, as the door may be opened even if the inside lock button is in locked position.
- Set the rear door child-protector locks when children are seated in the rear seats.

Access panels (smart-cab models only)

The access panels (rear door) can be opened using the inside handle.

- 1 Open the front door widely.
- 2 Pull (from the outside) or push (from the inside) the inside handle of the access panels.

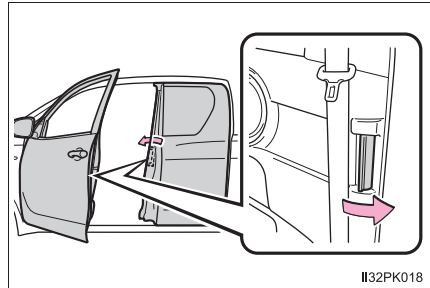

- 3 Open the access panels.

You can open and close the access panels only when the front door is widely opened.



NOTICE

■ When opening or closing the front door and access panels

The front door and access panels could be damaged if they hit each other when being opened or closed.

Tailgate*

The tailgate can be locked/unlocked and opened by the following procedures.

Locking and unlocking the tailgate (vehicles with key hole)

- ① Lock with the master key or the mechanical key
- ② Unlock with the master key or the mechanical key

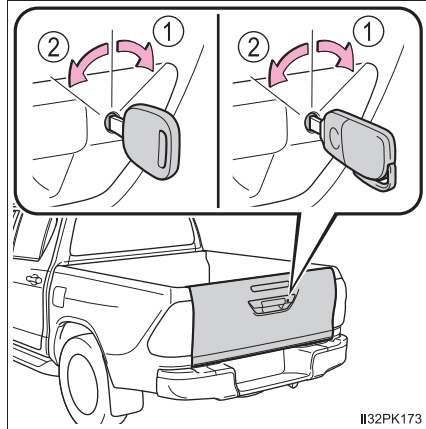

Opening the tailgate

► Type A

Unlock the latches and open the tailgate slowly.

The support stays will hold the tailgate horizontal.

After closing the tailgate, try pulling it toward you to make sure it is securely locked.

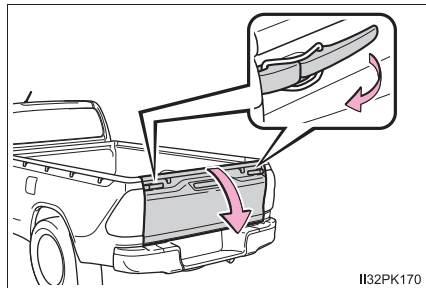

*: If equipped

► Type B

Pull the handle and open the tailgate slowly.

The support stays will hold the tailgate horizontal.

After closing the tailgate, try pulling it toward you to make sure it is securely locked.

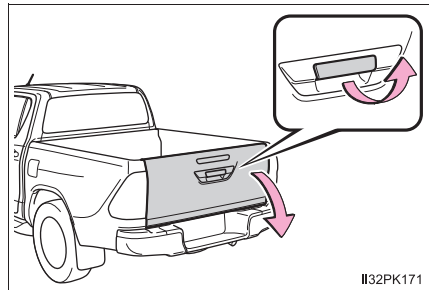
**Lowering the tailgate (vehicles without rear bumper)**

Release the brackets on the support stays from the lugs on both sides as shown in the illustration.

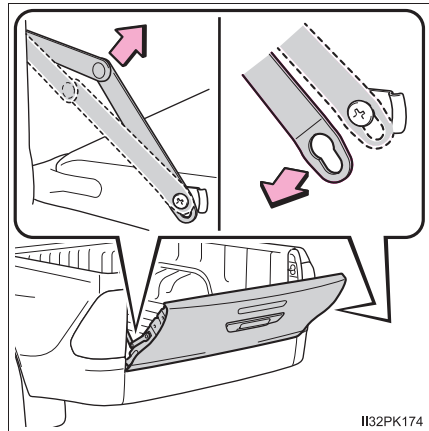
**Rear step bumper (if equipped)**

The rear step bumper is for rear end protection and easier step-up loading.

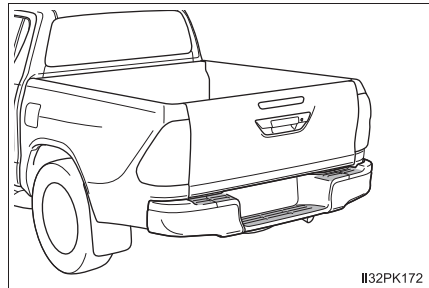

 **WARNING**

Observe the following precautions.
Failure to do so may result in death or serious injury.

■ **Caution while driving**

- Do not drive with the tailgate open.
- Do not get on the rear step bumper.

■ **When opening or closing the tailgate**

- Check the safety of the surrounding area, and be careful not to catch fingers etc. in the tailgate.
- Do not allow a child to open or close the tailgate. Doing so may cause the child's hand, head, arm or neck to be caught in the tailgate, resulting in death or serious injury.
- On an incline, it may be more difficult to open or close the tailgate than on a level surface.
Also, the tailgate may suddenly open or close. Be careful not to catch fingers etc. in the tailgate.
- When pulling the handle or releasing the support stays, hold and operate them properly. Failure to do so may cause the hands etc. to be caught, resulting in serious injury or an unexpected accident.
- Be careful when opening or closing the tailgate in windy weather, as it may forcefully move.
- After closing the tailgate, make sure it is securely locked.

 **NOTICE**

■ **To prevent damage to the rear step bumper**

Do not allow more than one person to get on the rear step bumper at a time.

■ **Handling of the tailgate (vehicles with rear bumper)**

If the support stays are removed, the tailgate comes into contact with the rear bumper and may be damaged.

Smart entry & start system*

The following operations can be performed simply by carrying the electronic key on your person, for example in your pocket. The driver should always carry the electronic key.

- Locks and unlocks the doors (→P. 111)
- Starts and stops the engine (→P. 176)

■ Antenna location

- ① Antennas outside the cabin
- ② Antennas inside the cabin

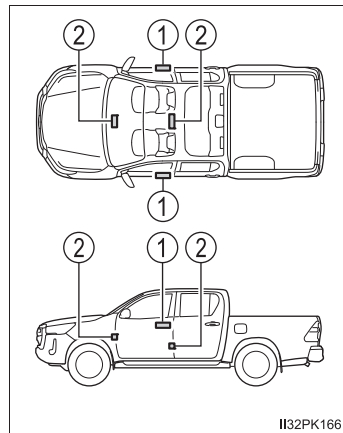

*: If equipped

■ Effective range (areas within which the electronic key is detected)

- When locking or unlocking the doors

The system can be operated when the electronic key is within about 0.7 m (2.3 ft.) of either of the lock/unlock button on the outside door handle. (Only the doors detecting the key can be operated.)

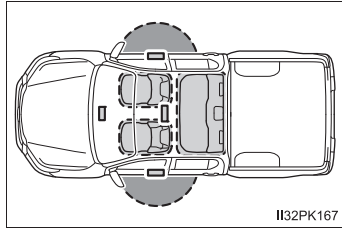

- When starting the engine or changing engine switch modes



The system can be operated when the electronic key is inside the vehicle. (The electronic key is not detected when it is on the floor or on the instrument panel.)

■ Battery-saving function

The battery-saving function will be activated in order to prevent the battery from being discharged while the vehicle is not in operation for a long time.

■ Electronic Key Battery-Saving Function

When battery-saving mode is set, battery depletion is minimized by stopping the electronic key from receiving radio waves.

Press  twice while pressing and holding . Confirm that the electronic key indicator flashes 4 times.

While the battery-saving mode is set, the smart entry & start system cannot be used. To cancel the function, press any of the electronic key buttons.

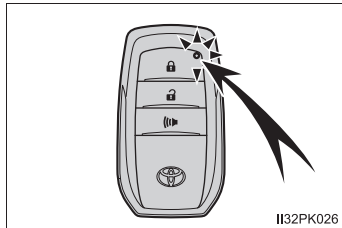

■ Alarms and warning indicators

A combination of exterior and interior alarms as well as warning messages shown on the multi-information display are used to prevent theft of the vehicle and accidents resulting from erroneous operation. Take appropriate measures in response to any warning message on the multi-information display.

The following table describes circumstances and correction procedures when only alarms are sounded.

Alarm	Situation	Correction procedure
Exterior alarm sounds once for 5 seconds	An attempt was made to lock the vehicle while a door was open.	Close all of the doors and lock the doors again.
Interior alarm pings continuously	The engine switch was turned to ACCESSORY mode while the driver's door was open (or the driver's door was opened while the engine switch was in ACCESSORY mode).	Turn the engine switch off and close the driver's door.

■ Conditions affecting operation

The smart entry & start system uses weak radio waves. In the following situations, the communication between the electronic key and the vehicle may be affected, preventing the smart entry & start system, wireless remote control and engine immobilizer system from operating properly.

(Ways of coping: →P. 450)

- When the electronic key battery is depleted
- Near a TV tower, electric power plant, gas station, radio station, large display, airport or other facility that generates strong radio waves or electrical noise
- When carrying a portable radio, cellular phone, cordless phone or other wireless communication device
- When the electronic key is in contact with, or is covered by the following metallic objects
 - Cards to which aluminum foil is attached
 - Cigarette boxes that have aluminum foil inside
 - Metallic wallets or bags
 - Coins
 - Hand warmers made of metal
 - Media such as CDs and DVDs
- When multiple electronic keys are in the vicinity
- When other wireless keys (that emit radio waves) are being used nearby
- When carrying the electronic key together with the following devices that emit radio waves
 - Another vehicle's electronic key or a wireless key that emits radio waves
 - Personal computers or personal digital assistants (PDAs)
 - Digital audio players
 - Portable game systems
- If window tint with a metallic content or metallic objects are attached to the rear window
- When the electronic key is placed near a battery charger or electronic devices

■ Note for the entry function

- Even if the electronic key is within the effective range (detection areas) when locking or unlocking the doors, the system may not operate properly if the electronic key is too close to the window or outside door handle, near the ground, or in a high place.
- Do not leave the electronic key on top of the instrument panel or near the door pockets when exiting the vehicle. Depending on the radio wave reception conditions, it may be detected by the antenna outside the cabin and the doors will become lockable from the outside, possibly trapping the electronic key inside the vehicle.
- As long as the electronic key is within the effective range, the doors may be locked or unlocked by anyone. However, only the doors detecting the electronic key can be used to unlock the vehicle.
- Even if the electronic key is not inside the vehicle, it may be possible to start the engine if the electronic key is near the window.
- If the wireless remote control is used to lock the doors when the electronic key is near the vehicle, there is a possibility that the door may not be unlocked by the entry function. (Use the wireless remote control to unlock the doors.)
- Pulling the outside door handle while pressing the lock/unlock button on the outside door handle may prevent the doors from being unlocked. In this case, return the door handle to the original position, press the lock/unlock button again, and check that the doors unlock before pulling the door handle again.
- Unlocking the vehicle may take more time if another electronic key is within the effective range.

■ When the vehicle is not driven for extended periods

- To prevent theft of the vehicle, do not leave the electronic key within 2 m (6 ft.) of the vehicle.
- The smart entry & start system can be deactivated in advance. Ask your Toyota dealer for details.

■ To operate the system properly

Make sure to carry the electronic key when operating the system. Do not get the electronic key too close to the vehicle when operating the system from the outside of the vehicle.

Depending on the position and holding condition of the electronic key, the key may not be detected correctly and the system may not operate properly. (The alarm may go off accidentally, or the door lock prevention function may not operate.)

■ If the smart entry & start system does not operate properly

- Locking and unlocking the doors: Use the mechanical key. (→P. 450)
- Starting the engine: →P. 451

■ Electronic key battery depletion

- The standard battery life is 1 to 2 years.
- If the battery becomes low, an alarm will sound in the cabin when the engine stops.
- As the electronic key always receives radio waves, the battery will become depleted even if the electronic key is not used. The following symptoms indicate that the electronic key battery may be depleted. Replace the battery when necessary. (→P. 373)
 - The smart entry & start system or the wireless remote control does not operate.
 - The detection area becomes smaller.
 - The LED indicator on the key surface does not turn on.
- To avoid serious deterioration, do not leave the electronic key within 1 m (3 ft.) of the following electrical appliances that produce a magnetic field:
 - TVs
 - Personal computers
 - Cellular phones, cordless phones and battery chargers
 - Recharging cellular phones or cordless phones
 - Table lamps
 - Induction cookers

■ If “Key left inside vehicle” is shown on the multi-information display

An attempt was made to lock the doors using the smart entry & start system while the electronic key was still inside the vehicle, or an attempt was made to lock either front door by opening a door and putting the inside lock button into the lock position, then closing the door by pulling on the outside door handle with the electronic key still inside the vehicle.

Retrieve the electronic key from the vehicle and lock the doors again.

■ Customization that can be configured at your Toyota dealer

Settings (e.g. smart entry & start system) can be changed.
(Customizable features: →P. 483)

■ If the smart entry & start system has been deactivated in a customized setting

- Locking and unlocking the doors:
Use the wireless remote control or mechanical key. (→P. 111, 450)
- Starting the engine and changing engine switch modes: →P. 451
- Stopping the engine: →P. 178

 **WARNING****■ Caution regarding interference with electronic devices**

- People with implantable cardiac pacemakers, cardiac resynchronization therapy-pacemakers or implantable cardioverter defibrillators should maintain a reasonable distance between themselves and the smart entry & start system antennas. (→P. 120)

The radio waves may affect the operation of such devices. If necessary, the entry function can be disabled. Ask your Toyota dealer for details, such as the frequency of radio waves and timing of the emitting radio waves. Then, consult your doctor to see if you should disable the entry function.

- Users of any electrical medical device other than implantable cardiac pacemakers, cardiac resynchronization therapy-pacemakers or implantable cardioverter defibrillators should consult the manufacturer of the device for information about its operation under the influence of radio waves.

Radio waves could have unexpected effects on the operation of such medical devices.

Ask your Toyota dealer for details on disabling the entry function.

Front seats

Adjustment procedure

► Manual seat

- ① Seat position adjustment lever
- ② Seatback angle adjustment lever
- ③ Vertical height adjustment lever (if equipped for driver's seat only)

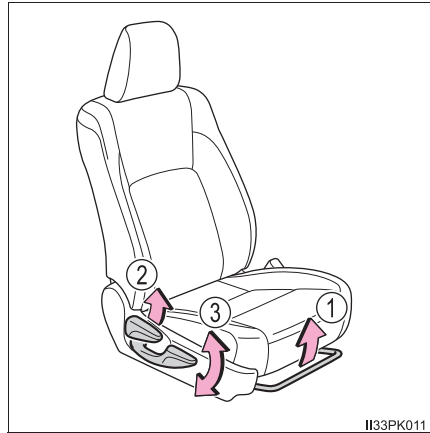

► Power seat (driver's seat only)

- ① Seat position adjustment switch
- ② Seatback angle adjustment switch
- ③ Seat cushion (front) angle adjustment switch
- ④ Vertical height adjustment switch

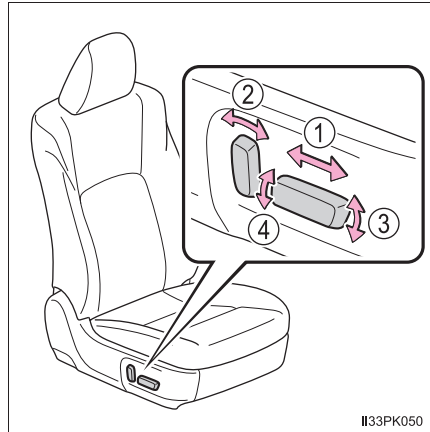

 **WARNING****■ When adjusting the seat position**

- Take care when adjusting the seat position to ensure that other passengers are not injured by the moving seat.
- Do not put your hands under the seat or near the moving parts to avoid injury.
Fingers or hands may become jammed in the seat mechanism.

■ Seat adjustment

- To reduce the risk of sliding under the lap belt during a collision, do not recline the seat more than necessary.
If the seat is too reclined, the lap belt may slide past the hips and apply restraint forces directly to the abdomen, or your neck may contact the shoulder belt, increasing the risk of death or serious injury in the event of an accident.
Adjustments should not be made while driving as the seat may unexpectedly move and cause the driver to lose control of the vehicle.
- Manual seat: After adjusting the seat, make sure that the seat is locked in position.

Rear seats*

Raising the bottom cushion (double-cab models with integrated type rear seat)

- 1 Pull the head restraint up.

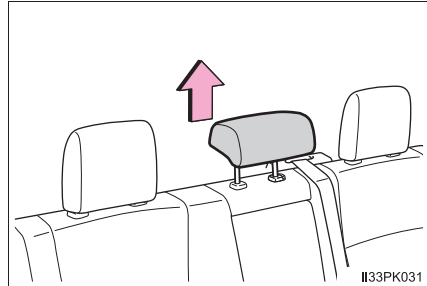

- 2 Pull the strap and raise the bottom cushion.

The latch under the bottom cushion will release allowing the bottom cushion to be raised.

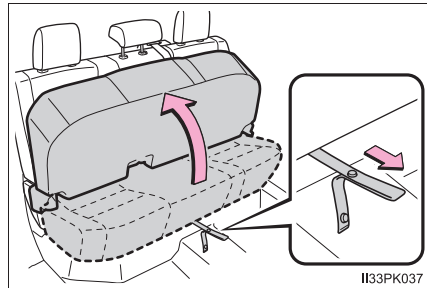

- 3 Anchor the strap to the head restraint.

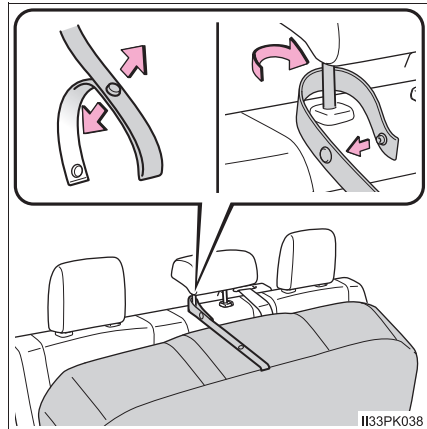

*: If equipped

Raising the bottom cushion (double-cab models with separated type rear seats)

- 1 Pull the head restraints up.

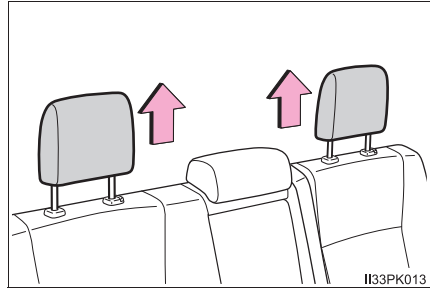

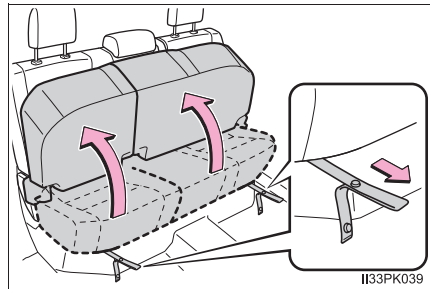

- 2 Pull the straps and raise the bottom cushions.

The latch under the bottom cushions will release allowing the bottom cushions to be raised.

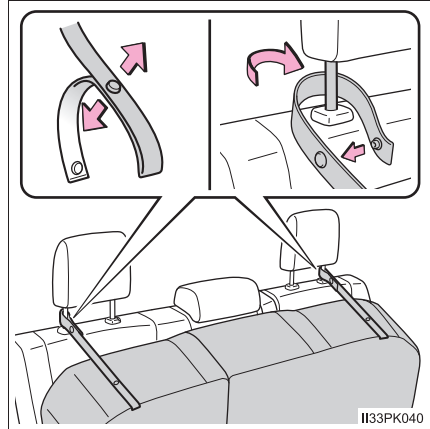

- 3 Anchor the straps to the head restraints.



 **WARNING**

Observe the following precautions. Failure to do so may result in death or serious injury.

■ When raising the bottom cushion

- Do not operate the bottom cushion while driving.
- Stop the vehicle on level ground, apply the parking brake firmly and shift the shift position to P (automatic transmission) or N (manual transmission).

■ When returning the bottom cushions to their original position

- Be careful not to get your hands or feet pinched in the seat.
- Make sure there are no obstacles under the seat which would prevent the seat from properly locking into place.
- Make sure the bottom cushion are securely locked by pushing it upward and downward.
- Check that the seat belts are not twisted or caught in the bottom cushions.

Head restraints

Head restraints are provided for all seats.

Front seats

► Adjustable type

① Up

Pull the head restraints up.

② Down

Push the head restraint down while pressing the lock release button.

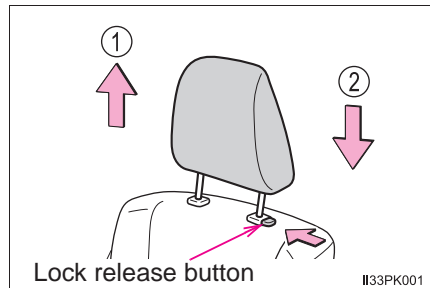

► Integrated type

Head restraints cannot be adjusted and removed.

Rear seats (if equipped)

► Adjustable type

① Up

Pull the head restraints up.

② Down

Push the head restraint down while pressing the lock release button.

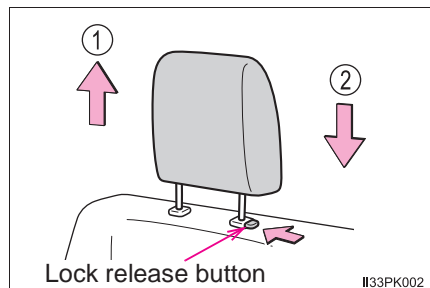

► Integrated type

Head restraints cannot be adjusted and removed.

■ Removing the head restraints

Pull the head restraint up while pressing the lock release button.

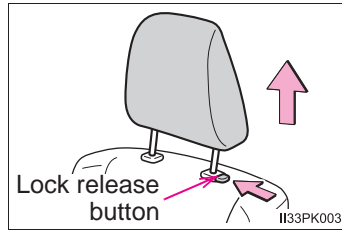

■ Installing the head restraints

Align the head restraint with the installation holes and push it down to the lock position.

Press and hold the lock release button when lowering the head restraint.

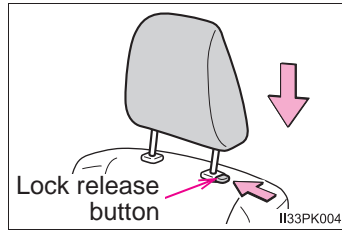

■ Adjusting the height of the head restraints

Make sure that the head restraints are adjusted so that the center of the head restraint is closest to the top of your ears.

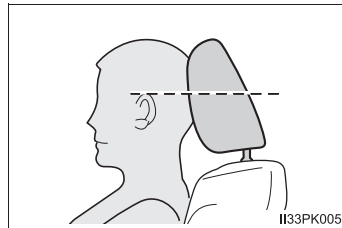

■ Adjusting the rear center seat head restraint (double-cab models only)

Always raise the head restraint one level from the stowed position when using.

 **WARNING****■ Head restraint precautions**

Observe the following precautions regarding the head restraints. Failure to do so may result in death or serious injury.

- Use the head restraints designed for each respective seat.
- Adjust the head restraints to the correct position at all times.
- After adjusting the head restraints, push down on them and make sure they are locked in position.
- Do not drive with the head restraints removed.

Steering wheel

Adjustment procedure

- 1 Hold the steering wheel and push the lever down.

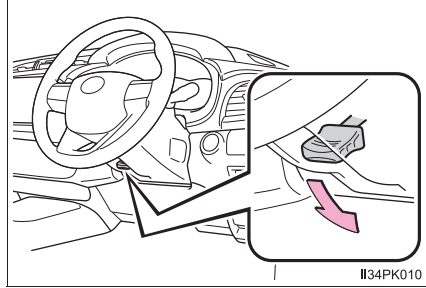

Type A

- 2 Adjust to the ideal position by moving the steering wheel vertically.

After adjustment, pull the lever up to secure the steering wheel.

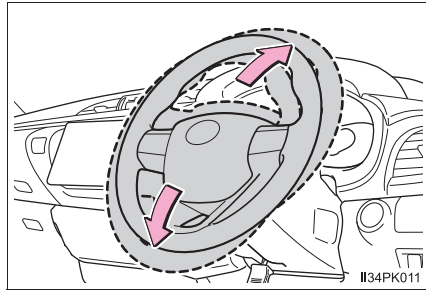

Type B

- 2 Adjust to the ideal position by moving the steering wheel horizontally and vertically.

After adjustment, pull the lever up to secure the steering wheel.

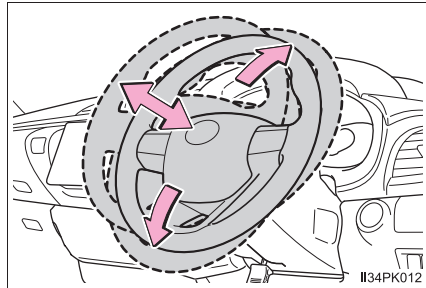

Horn

To sound the horn, press on or close to the  mark.

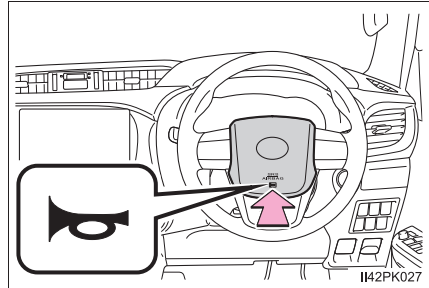

■ After adjusting the steering wheel

Make sure that the steering wheel is securely locked.

The horn may not sound if the steering wheel is not securely locked.

WARNING

■ Caution while driving

Do not adjust the steering wheel while driving.

Doing so may cause the driver to mishandle the vehicle and cause an accident, resulting in death or serious injury.

■ After adjusting the steering wheel

Make sure that the steering wheel is securely locked.

Otherwise, the steering wheel may move suddenly, possibly causing an accident, and resulting in death or serious injury.

Inside rear view mirror

The rear view mirror's position can be adjusted to enable sufficient confirmation of the rear view.

Adjusting the height of rear view mirror

The height of the rear view mirror can be adjusted to suit your driving posture.

Adjust the height of the rear view mirror by moving it up and down.

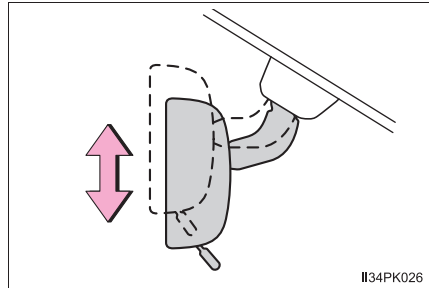

Anti-glare function

► Manual anti-glare inside rear view mirror

Reflected light from the headlights of vehicles behind can be reduced by operating the lever.

- ① Normal position
- ② Anti-glare position

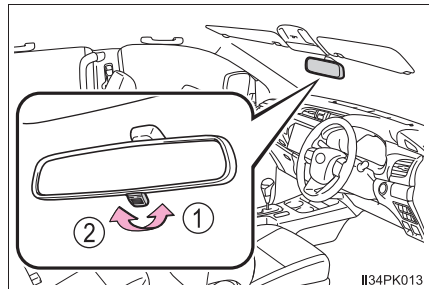

► Auto anti-glare inside rear view mirror

Responding to the level of brightness of the headlights of vehicles behind, the reflected light is automatically reduced.

Changing automatic anti-glare function mode

ON/OFF

When the automatic anti-glare function is in ON mode, the indicator illuminates.

The function will set to ON mode each time the engine switch is turned to IGNITION ON mode.

Pressing the button turns the function to OFF mode. (The indicator also turns off.)

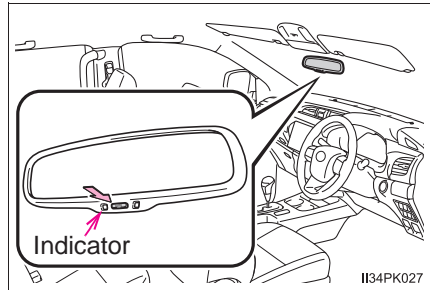

■ To prevent sensor error (vehicles with auto anti-glare inside rear view mirror)

To ensure that the sensors operate properly, do not touch or cover them.

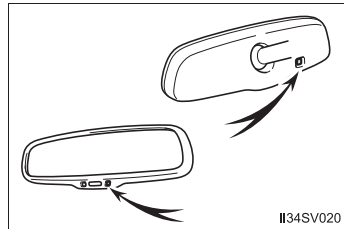

⚠ WARNING

Do not adjust the position of the mirror while driving. Doing so may lead to mishandling of the vehicle and cause an accident, resulting in death or serious injury.

Outside rear view mirrors

Adjustment procedure

1 To select a mirror to adjust, turn the switch.

- ① Left
- ② Right

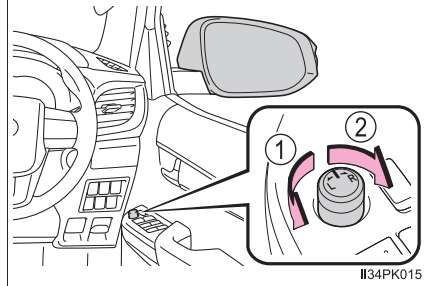

2 To adjust the mirror, move the switch.

- ① Up
- ② Right
- ③ Down
- ④ Left

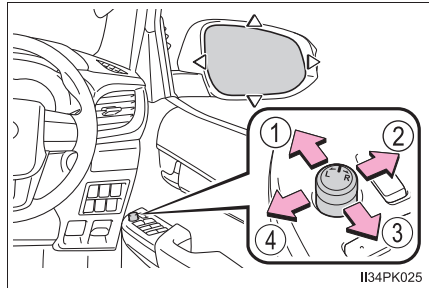

Folding the mirrors

▶ Manual folding type

Push the mirror back in the direction of the vehicle's rear.

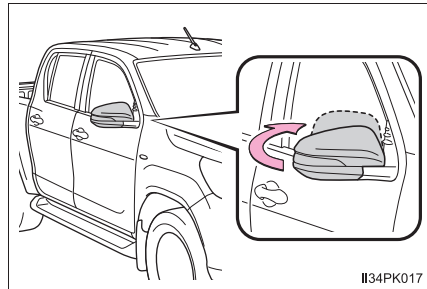

▶ Power folding type

Press the switch.

- ① Folding
- ② Extending

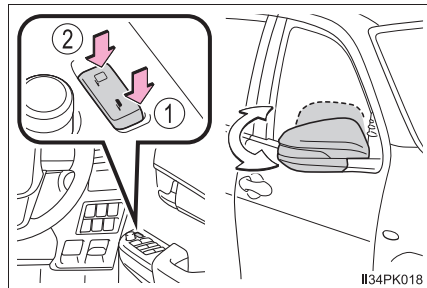

■ Mirror angle can be adjusted when

▶ Vehicles without smart entry & start system

The engine switch is in the "ACC" or "ON" position.

▶ Vehicles with smart entry & start system

The engine switch is in ACCESSORY or IGNITION ON mode.

■ When the mirrors are fogged up (vehicles with outside rear view mirror defoggers)

The outside rear view mirrors can be cleared using the mirror defoggers. Turn on the rear window defogger to turn on the outside rear view mirror defoggers. (→P. 313)

 **WARNING****■ Important points while driving**

Observe the following precautions while driving.

Failure to do so may result in loss of control of the vehicle and cause an accident, resulting in death or serious injury.

- Do not adjust the mirrors while driving.
- Do not drive with the mirrors folded.
- Both the driver and passenger side mirrors must be extended and properly adjusted before driving.

■ When a mirror is moving

To avoid personal injury and mirror malfunction, be careful not to get your hand caught by the moving mirror.

■ When the mirror defoggers are operating (vehicles with outside rear view mirror defoggers)

Do not touch the rear view mirror surfaces, as they can become very hot and burn you.

 **NOTICE****■ If ice should jam the mirror**

Do not operate the control or scrape the mirror face. Use a spray de-icer to free the mirror.

Power windows

Opening and closing procedures

The power windows can be opened and closed using the switches.

Operating the switch moves the windows as follows:

► Type A

- ① Closing
- ② Opening
- ③ One-touch opening*
- (driver's window only)
- ④ One-touch closing*
- (driver's window only)

*: To stop the window partway, operate the switch in the opposite direction.

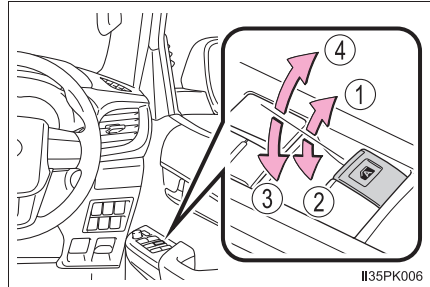

II35PK006

► Type B

- ① Closing
- ② Opening
- ③ One-touch opening*
- (all windows)
- ④ One-touch closing*
- (all windows)

*: To stop the window partway, operate the switch in the opposite direction.

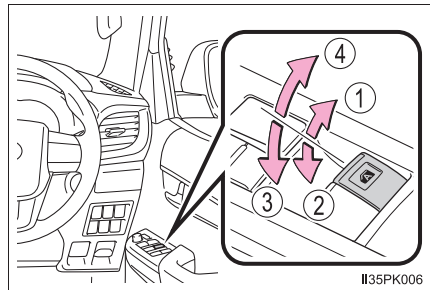

II35PK006

Window lock switch

Press the switch down to lock the passenger window switches.

Use this switch to prevent children from accidentally opening or closing a passenger window.

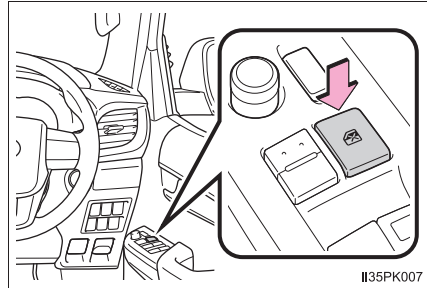

■ The power windows can be operated when

- ▶ Vehicles without smart entry & start system
The engine switch is in the “ON” position.
- ▶ Vehicles with smart entry & start system
The engine switch is in IGNITION ON mode.

■ Jam protection function (windows with one-touch function only)

If an object becomes jammed between the window and the window frame while the window is closing, window movement is stopped and the window is opened slightly.

■ Catch protection function (windows with one-touch function only)

If an object becomes caught between the door and window while the window is opening, window movement is stopped.

■ Operating the power windows after turning the engine off

- ▶ Vehicles without smart entry & start system

The power windows can be operated for approximately 45 seconds even after the engine switch is turned to the “ACC” or “LOCK” position. They cannot, however, be operated once either front door is opened.

- ▶ Vehicles with smart entry & start system

The power windows can be operated for approximately 45 seconds even after the engine switch is turned to ACCESSORY mode or turned off. They cannot, however, be operated once either front door is opened.

■ When the window cannot be opened or closed (windows with one-touch function only)

When the jam protection function or catch protection function operates unusually and the window cannot be opened or closed, perform the following operations with the power window switch of that door.

- Stop the vehicle. With the engine switch in the “ON” position (vehicles without smart entry & start system) or IGNITION ON mode (vehicles with smart entry & start system), within 4 seconds of the jam protection function or catch protection function activating, continually operate the power window switch in the one-touch closing direction or one-touch opening direction so that the window can be opened and closed.
- If the window cannot be opened and closed even when performing the above operations, perform the following procedure for function initialization.
 - 1 Turn the engine switch to the “ON” position (vehicles without smart entry & start system) or IGNITION ON mode (vehicles with smart entry & start system).
 - 2 Pull and hold the power window switch in the one-touch closing direction and completely close the window.
 - 3 Release the power window switch for a moment, resume pulling the switch in the one-touch closing direction, and hold it there for approximately 6 seconds or more.
 - 4 Press and hold the power window switch in the one-touch opening direction. After the window is completely opened, continue holding the switch for an additional 1 second or more.
 - 5 Release the power window switch for a moment, resume pushing the switch in the one-touch opening direction, and hold it there for approximately 4 seconds or more.
 - 6 Pull and hold the power window switch in the one-touch closing direction again. After the window is completely closed, continue holding the switch for a further 1 second or more.

If you release the switch while the window is moving, start again from the beginning.

If the window reverses and cannot be fully closed or opened, have the vehicle inspected by your Toyota dealer.

 **WARNING**

Observe the following precautions.
Failure to do so may result in death or serious injury.

■ **Closing the windows**

- The driver is responsible for all the power window operations, including the operation for the passengers. In order to prevent accidental operation, especially by a child, do not let a child operate the power windows. It is possible for children and other passengers to have body parts caught in the power window. Also, when riding with a child, it is recommended to use the window lock switch. (→P. 143)
- Check to make sure that all passengers do not have any part of their body in a position where it could be caught when a window is being operated.
- When exiting the vehicle, turn the engine switch off, carry the key and exit the vehicle along with the child. There may be accidental operation, due to mischief, etc., that may possibly lead to an accident.

■ **Jam protection function (windows with one-touch function only)**

- Never use any part of your body to intentionally activate the jam protection function.
- The jam protection function may not work if something gets jammed just before the window is fully closed. Be careful not to get any part of your body jammed in the window.

■ **Catch protection function (windows with one-touch function only)**

- Never use any part of your body or clothing to intentionally activate the catch protection function.
- The catch protection function may not work if something gets caught just before the window is fully opened. Be careful not to get any part of your body or clothing caught in the window.

 **NOTICE**

■ **Jam protection function and catch protection function (windows with one-touch function only)**

If the door is forcefully closed while the window is being opened or closed, the jam protection function or catch protection function may operate and the window may reverse directions or stop.

Quarter windows (smart-cab models)

Opening and closing procedures

The quarter windows can be opened and closed using the latch handle.

To open the quarter windows, pull the latch handle toward you and swing it fully out.

To close the quarter windows, reverse the opening procedure.

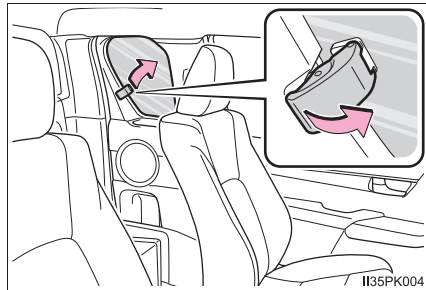

■ Closing the quarter windows

Make sure that the quarter windows are securely closed after closing them.

WARNING

■ Opening or closing the quarter windows

Observe the following precautions.

Failure to do so may result in death or serious injury.

- Check to make sure that all passengers do not have any part of their body in a position where it could be caught when a window is being operated.
- Do not allow children to operate the quarter windows.
Closing a quarter window on someone can cause serious injury, and in some instances, even death.

- 4-1. Before driving**
- Driving the vehicle 148
 - Cargo and luggage 161
 - Trailer towing 162
- 4-2. Driving procedures**
- Engine (ignition) switch
(vehicles without smart
entry & start system)..... 173
 - Engine (ignition) switch
(vehicles with smart
entry & start system)..... 176
 - Automatic transmission 184
 - Manual transmission..... 191
 - Turn signal lever 198
 - Parking brake 199
- 4-3. Operating the lights
and wipers**
- Headlight switch.....200
 - Fog light switch204
 - Windshield wipers and
washer205
- 4-4. Refueling**
- Opening the fuel tank
cap208
- 4-5. Using the driving support
systems**
- Toyota Safety Sense213
 - PCS (Pre-Collision
System)220
 - LDA (Lane Departure
Alert With Yaw Assist
Function).....231
 - RSA (Road Sign Assist).....242
 - Dynamic radar cruise
control246
 - Toyota parking
assist-sensor262
 - Four-wheel drive system....270
 - Rear differential lock
system280
 - Driving assist systems284
 - Downhill assist control
system291
 - AUTO LSD.....294
 - DPF (Diesel Particulate
Filter) system296
- 4-6. Driving tips**
- Winter driving tips301

Driving the vehicle

The following procedures should be observed to ensure safe driving:

Starting the engine

→P. 173, 176

Driving

▶ Automatic transmission

- 1 With the brake pedal depressed, shift the shift lever to D.
(→P. 184)
- 2 Release the parking brake. (→P. 199)
- 3 Gradually release the brake pedal and gently depress the accelerator pedal to accelerate the vehicle.

▶ Manual transmission

- 1 While depressing the clutch pedal, shift the shift lever to 1.
(→P. 191)
- 2 Release the parking brake. (→P. 199)
- 3 Gradually release the clutch pedal. At the same time, gently depress the accelerator pedal to accelerate the vehicle.

Stopping

▶ Automatic transmission

- 1 With the shift lever in D, depress the brake pedal.
- 2 If necessary, set the parking brake.

If the vehicle is to be stopped for an extended period of time, shift the shift lever to P or N. (→P. 184)

▶ Manual transmission

- 1 While depressing the clutch pedal, depress the brake pedal.
- 2 If necessary, set the parking brake.

If the vehicle is to be stopped for an extended period of time, shift the shift lever to N. (→P. 191)

Parking the vehicle

▶ Automatic transmission

- 1 With the shift lever in D, depress the brake pedal.
- 2 Set the parking brake (→P. 199), and shift the shift lever to P (→P. 184).
- 3 Vehicles without smart entry & start system:
Turn the engine switch to the “LOCK” position to stop the engine.
Vehicles with smart entry & start system:
Press the engine switch to stop the engine.
- 4 Lock the door, making sure that you have the key on your person.
If parking on a hill, block the wheels as needed.

▶ Manual transmission

- 1 While depressing the clutch pedal, depress the brake pedal.
- 2 Shift the shift lever to N. (→P. 191)
If parking on a hill, shift the shift lever to 1 or R as needed.
- 3 Set the parking brake. (→P. 199)
- 4 Vehicles without smart entry & start system:
Turn the engine switch to the “LOCK” position to stop the engine.
Vehicles with smart entry & start system:
Press the engine switch to stop the engine.
- 5 Lock the door, making sure that you have the key on your person.
If parking on a hill, block the wheels as needed.

Starting off on a steep uphill

▶ Automatic transmission

- 1 Make sure that the parking brake is set and shift the shift lever to D.
- 2 Gently depress the accelerator pedal.
- 3 Release the parking brake.

▶ Manual transmission

- 1 With the parking brake firmly set and the clutch pedal fully depressed, shift the shift lever to 1.
- 2 Lightly depress the accelerator pedal at the same time as gradually releasing the clutch pedal.
- 3 Release the parking brake.

■ When starting off on an uphill

The hill-start assist control will activate. (→P. 284)

■ Driving in the rain

- Drive carefully when it is raining, because visibility will be reduced, the windows may become fogged-up, and the road will be slippery.
- Drive carefully when it starts to rain, because the road surface will be especially slippery.
- Refrain from high speeds when driving on an expressway in the rain, because there may be a layer of water between the tires and the road surface, preventing the steering and brakes from operating properly.

■ Engine speed while driving (automatic transmission)

In the following conditions, the engine speed may become high while driving. This is due to automatic up-shifting control or down-shifting implementation to meet driving conditions. It does not indicate sudden acceleration.

- The vehicle is judged to be driving uphill or downhill
- When the accelerator pedal is released

■ Restraining the engine output (Brake Override System)

- When the accelerator and brake pedals are depressed at the same time, the engine output may be restrained.
- A warning message is displayed on the multi-information display while the system is operating. (→P. 428)

■ Restraining sudden start (Drive-Start Control) (vehicles with automatic transmission)

- When the following unusual operation is performed, the engine output may be restrained.
 - When the shift lever is shifted from R to D, D to R, N to R, P to D, or P to R (D includes S) with the accelerator pedal depressed, a warning message is displayed on the multi-information display while the system is operating. If a warning message is shown on the multi-information display, read the message and follow the instructions.
 - When the accelerator pedal is depressed too much while the vehicle is in reverse.
- While Drive-Start Control is being activated, your vehicle may have trouble escaping from the mud or fresh snow. In such case, perform the following actions to cancel Drive-Start Control so that the vehicle may become able to escape from the mud or fresh snow.
 - Deactivate TRC/A-TRC (→P. 286)
 - Turn the front-wheel drive control switch to L4. (if equipped) (→P. 270)
- Vehicles with AUTO LSD system: Drive-Start Control does not work when the AUTO LSD system is turned on. (→P. 294)

■ Reduction of engine power (diesel engine)

To protect the engine when driving in severe circumstances such as extreme high ambient temperatures and prolonged high-load driving (including when towing), the engine power will be reduced due to a rise in coolant temperature.

However, when the engine coolant temperature falls, the power reduction is canceled and the engine returns to the normal operation.

If the engine coolant temperature gauge enters the red zone, see “If your vehicle overheats” (→P. 459).

■ Breaking in your new Toyota

To extend the life of the vehicle, observing the following precautions is recommended:

- For the first 300 km (200 miles):
Avoid sudden stops.
- For the first 800 km (500 miles):
Do not tow a trailer. (→P. 162)
- For the first 1000 km (600 miles):
 - Do not drive at extremely high speeds.
 - Avoid sudden acceleration.
 - Do not drive continuously in the low gears.
 - Do not drive at a constant speed for extended periods.
 - Do not drive slowly with the manual transmission in a high gear.

■ Idling time before engine stop (diesel engine only)

To prevent damage to the turbocharger, allow the engine to idle immediately after high-load driving.

Driving condition	Idling time
Normal city driving or high-speed driving (at the highway speed limit or recommended speed)	Not necessary
Steep hill driving, continuous driving (race track driving etc.), or towing a trailer or another vehicle	Approximately 1 minute

■ Operating your vehicle in a foreign country

Comply with the relevant vehicle registration laws and confirm the availability of the correct fuel. (→P. 470)

■ Eco-friendly driving

→P. 87

 **WARNING**

Observe the following precautions.

Failure to do so may result in death or serious injury.

■ **When starting the vehicle**

On vehicles with automatic transmission, always keep your foot on the brake pedal while stopped with the engine running. This prevents the vehicle from creeping.

■ **When driving the vehicle**

- Do not drive if you are unfamiliar with the location of the brake and accelerator pedals to avoid depressing the wrong pedal.
 - Accidentally depressing the accelerator pedal instead of the brake pedal will result in sudden acceleration that may lead to an accident.
 - When backing up, you may twist your body around, leading to a difficulty in operating the pedals. Make sure to operate the pedals properly.
 - Make sure to keep a correct driving posture even when moving the vehicle only slightly. This allows you to depress the brake and accelerator pedals properly.
 - Depress the brake pedal using your right foot. Depressing the brake pedal using your left foot may delay response in an emergency, resulting in an accident.
- Do not drive the vehicle over or stop the vehicle near flammable materials. The exhaust system and exhaust gases can be extremely hot. These hot parts may cause a fire if there is any flammable material nearby.
- During normal driving, do not turn off the engine. Turning the engine off while driving will not cause loss of steering or braking control, but the power assist to these systems will be lost. This will make it more difficult to steer and brake, so you should pull over and stop the vehicle as soon as it is safe to do so.

However, in the event of an emergency, such as if it becomes impossible to stop the vehicle in the normal way: →P. 411

 **WARNING**

Observe the following precautions.

Failure to do so may result in death or serious injury.

■ **When driving the vehicle**

- Use engine braking (downshift) to maintain a safe speed when driving down a steep hill.
Using the brakes continuously may cause the brakes to overheat and lose effectiveness. (→P. 185)
- Do not adjust the positions of the steering wheel, the seat, or the inside or outside rear view mirrors while driving.
Doing so may result in a loss of vehicle control.
- Always check that all passengers' arms, heads or other parts of their body are not outside the vehicle.
- On vehicles with manual transmission, observe the following to prevent the clutch from being damaged.
 - Do not operate the clutch halfway for a long period of time unless it is necessary.
 - Do not operate the clutch half or partial engaged to control the vehicle speed, such as to drive the vehicle at a low speed, to hold the vehicle on a slope, etc.
 - Do not depress the brake pedal during operating the clutch half or partial engaged.
Doing so could not only speed up the clutch wear, but also damage the clutch or even cause a fatal accident such as vehicle fire.

■ **When driving on slippery road surfaces**

- Sudden braking, acceleration and steering may cause tire slippage and reduce your ability to control the vehicle.
- Sudden acceleration, engine braking due to shifting, or changes in engine speed could cause the vehicle to skid.
- After driving through a puddle, lightly depress the brake pedal to make sure that the brakes are functioning properly. Wet brake pads may prevent the brakes from functioning properly. If the brakes on only one side are wet and not functioning properly, steering control may be affected.

 **WARNING**

Observe the following precautions.

Failure to do so may result in death or serious injury.

■ **When shifting the shift lever**

- On vehicles with automatic transmission, do not let the vehicle roll backwards while the shift lever is in a driving position, or roll forward while the shift lever is in R.
Doing so may cause the engine to stall or lead to poor brake and steering performance, resulting in an accident or damage to the vehicle.
- On vehicles with automatic transmission, do not shift the shift lever to P while the vehicle is moving.
Doing so can damage the transmission and may result in a loss of vehicle control.
- Do not shift the shift lever to R while the vehicle is moving forward.
Doing so can damage the transmission and may result in a loss of vehicle control.
- Do not shift the shift lever to a driving position while the vehicle is moving backward.
Doing so can damage the transmission and may result in a loss of vehicle control.
- Moving the shift lever to N while the vehicle is moving will disengage the engine from the transmission. Engine braking is not available when N is selected.
- On vehicles with automatic transmission, be careful not to shift the shift lever with the accelerator pedal depressed. Shifting the shift lever to a gear other than P or N may lead to unexpected rapid acceleration of the vehicle that may cause an accident.

■ **If you hear a squealing or scraping noise (brake pad wear indicators)**

Have the brake pads checked and replaced by your Toyota dealer as soon as possible.

Rotor damage may result if the pads are not replaced when needed.

It is dangerous to drive the vehicle when the wear limits of the brake pads and/or those of the brake discs are exceeded.

 **WARNING**

Observe the following precautions.

Failure to do so may result in death or serious injury.

■ **When the vehicle is stopped**

- Do not race the engine.

If the vehicle is in any gear other than P (vehicles with automatic transmission only) or N, the vehicle may accelerate suddenly and unexpectedly, causing an accident.

- On vehicles with automatic transmission, in order to prevent accidents due to the vehicle rolling away, always keep depressing the brake pedal while the engine is running, and apply the parking brake as necessary.
- If the vehicle is stopped on an incline, in order to prevent accidents caused by the vehicle rolling forward or backward, always depress the brake pedal and securely apply the parking brake as needed.

- Avoid revving or racing the engine.

Running the engine at high speed while the vehicle is stopped may cause the exhaust system to overheat, which could result in a fire if combustible material is nearby.

■ **When the vehicle is parked**

- Do not leave glasses, cigarette lighters, spray cans, or soft drink cans in the vehicle when it is in the sun.

Doing so may result in the following:

- Gas may leak from a cigarette lighter or spray can, and may lead to a fire.
- The temperature inside the vehicle may cause the plastic lenses and plastic material of glasses to deform or crack.
- Soft drink cans may fracture, causing the contents to spray over the interior of the vehicle, and may also cause a short circuit in the vehicle's electrical components.
- Do not leave cigarette lighters in the vehicle. If a cigarette lighter is in a place such as the glove box or on the floor, it may be lit accidentally when luggage is loaded or the seat is adjusted, causing a fire.
- Do not attach adhesive discs to the windshield or windows. Do not place containers such as air fresheners on the instrument panel or dashboard. Adhesive discs or containers may act as lenses, causing a fire in the vehicle.
- Do not leave a door or window open if the curved glass is coated with a metallized film such as a silver-colored one. Reflected sunlight may cause the glass to act as a lens, causing a fire.

 **WARNING**

Observe the following precautions.
Failure to do so may result in death or serious injury.

■ When the vehicle is parked

- Always apply the parking brake, shift the shift lever to P (vehicles with automatic transmission only), stop the engine and lock the vehicle.
Do not leave the vehicle unattended while the engine is running.
If the vehicle is parked with the shift lever in P but the parking brake is not set, the vehicle may start to move, possibly leading to an accident.
- Do not touch the exhaust pipes while the engine is running or immediately after turning the engine off.
Doing so may cause burns.

■ When taking a nap in the vehicle

Always turn the engine off. Otherwise, if you accidentally move the shift lever or depress the accelerator pedal, this could cause an accident or fire due to engine overheating. Additionally, if the vehicle is parked in a poorly ventilated area, exhaust gases may collect and enter the vehicle, leading to death or a serious health hazard.

■ When braking

- When the brakes are wet, drive more cautiously.
Braking distance increases when the brakes are wet, and this may cause one side of the vehicle to brake differently than the other side. Also, the parking brake may not securely hold the vehicle.
- If the brake booster device does not operate, do not follow other vehicles closely and avoid hills or sharp turns that require braking. In this case, braking is still possible, but the brake pedal should be depressed more firmly than usual. Also, the braking distance will increase. Have your brakes fixed immediately.
- Do not pump the brake pedal if the engine stalls.
Each push on the brake pedal uses up the reserve for the power-assisted brakes.
- The brake system consists of 2 individual hydraulic systems: If one of the systems fails, the other will still operate. In this case, the brake pedal should be depressed more firmly than usual and the braking distance will increase.
Have your brakes fixed immediately.

■ If the vehicle becomes stuck (4WD models)

Do not spin the wheels excessively when any of the tires is up in the air, or the vehicle is stuck in sand, mud, etc. This may damage the driveline components or propel the vehicle forward or backward, causing an accident.



NOTICE

■ When driving the vehicle

- Do not depress the accelerator and brake pedals at the same time during driving, as this may restrain the engine output.
- On vehicles with automatic transmission, do not use the accelerator pedal or depress the accelerator and brake pedals at the same time to hold the vehicle on a hill.
- On vehicles with manual transmission, do not shift gears unless the clutch pedal is fully depressed. After shifting, do not release the clutch pedal abruptly. Doing so may damage the clutch, transmission and gears.
- On vehicles with manual transmission, observe the following to prevent the clutch from being damaged. Failure to do so may cause excessive premature wear or damage to the clutch, eventually making it difficult to accelerate and start off from a stop. Have the vehicle inspected by your Toyota dealer.
 - Do not rest your foot on the clutch pedal while driving.
Doing so may cause clutch trouble.
 - Do not use any gear other than the 1st gear when starting off and moving forward.
Doing so may damage the clutch.
 - Do not use the clutch to hold the vehicle when stopping on an uphill grade.
Doing so may damage the clutch.
 - Do not use the clutch pedal to adjust vehicle speed.
Doing so may damage the clutch.
 - When stopping the vehicle with the shift lever in a position other than N, make sure to fully depress the clutch pedal and stop the vehicle using the brakes.
- On vehicles with manual transmission, do not shift the shift lever to R without the vehicle completely stopped. Doing so may damage the clutch, transmission and gears.
- On vehicles with manual transmission, if you cannot accelerate the vehicle even when the clutch is engaged and the accelerator pedal is depressed, this may mean that the clutch is slipping, and the vehicle may be rendered undrivable. Have your Toyota dealer inspect the vehicle as soon as possible.

 NOTICE**■ When parking the vehicle**

On vehicles with automatic transmission, always set the parking brake, and shift the shift lever to P. Failure to do so may cause the vehicle to move or the vehicle may accelerate suddenly if the accelerator pedal is accidentally depressed.

■ Avoiding damage to vehicle parts

- Do not turn the steering wheel fully in either direction and hold it there for an extended period of time.
Doing so may damage the power steering pump.
- When driving over bumps in the road, drive as slowly as possible to avoid damaging the wheels, underside of the vehicle, etc.
- Diesel engine: Make sure to idle the engine immediately after high-load driving. Stop the engine only after the turbocharger has cooled down. Failure to do so may cause damage to the turbocharger.
- Diesel engine: In an extremely cold environment, idle the engine for more than 30 seconds after starting the engine. Do not race the engine while idling.

■ If you get a flat tire while driving

A flat or damaged tire may cause the following situations. Hold the steering wheel firmly and gradually depress the brake pedal to slow down the vehicle.

- It may be difficult to control your vehicle.
- The vehicle will make abnormal sounds or vibrations.
- The vehicle will lean abnormally.

Information on what to do in case of a flat tire. (→P. 431)

**NOTICE****■ When encountering flooded roads**

Do not drive on a road that has flooded after heavy rain etc. Doing so may cause the following serious damage to the vehicle:

- Engine stalling
- Short in electrical components
- Engine damage caused by water immersion

In the event that you drive on a flooded road and the vehicle is flooded, or on a sandy road, be sure to have your Toyota dealer check the following:

- Brake function
- Changes in quantity and quality of oil and fluid used for the engine, transmission, transfer (4WD models), clutch, differential, etc.
- Lubricant condition for the propeller shaft, bearings and suspension joints (where possible), and the function of all joints, bearings, etc.

Cargo and luggage

Take notice of the following information about storage precautions, cargo capacity and load.

WARNING

■ Things that must not be carried in the rear deck

The following things may cause a fire if loaded in the rear deck:

- Receptacles containing gasoline
- Aerosol cans

■ Storage precautions

Observe the following precautions.

Failure to do so may prevent the pedals from being depressed properly, may block the driver's vision, or may result in items hitting the driver or passengers, possibly causing an accident.

- Stow cargo and luggage in the rear deck whenever possible.
- Except for single-cab models: Do not stack anything behind the front seats higher than the seatbacks.
- Do not place cargo or luggage in or on the following locations.
 - At the feet of the driver
 - On the front passenger or rear seats (if equipped) (when stacking items)
 - On the instrument panel
 - On the dashboard
- Secure all items in the occupant compartment.
- Never allow anyone to ride in the rear deck. It is not designed for passengers. They should ride in their seats with their seat belts properly fastened. Otherwise, they are much more likely to suffer death or serious bodily injury, in the event of sudden braking, sudden swerving or an accident.

■ Load and distribution

- Do not overload your vehicle.
- Do not apply loads unevenly.

Improper loading may cause deterioration of steering or braking control which may cause death or serious injury.

Trailer towing

Your vehicle is designed primarily as a passenger-and-load-carrying vehicle. Towing a trailer will have an adverse effect on handling, performance, braking, durability, and fuel consumption. For your safety and the safety of others, do not overload the vehicle or trailer.

Toyota warranties do not apply to damage or malfunction caused by towing a trailer for commercial purposes.

For towing purposes, Toyota recommends the use of the following parts:

- When towing a caravan trailer etc., use a distributing hitch.
- When the total trailer weight is greater than the vehicle weight, use a sway control device.

◆ **Weight limits**

Confirm that the total trailer weight, gross vehicle weight, gross axle weight and trailer tongue load are all within the limits.

◆ Gross vehicle weight*

The gross vehicle weight must not exceed the following:

▶ 2WD models

Single-cab models: 2700 kg (5952 lb.)

Double-cab models: 2780 kg (6129 lb.)

▶ 4WD models

Single-cab models: 3050 kg (6724 lb.)

Smart-cab models: 3050 kg (6724 lb.) [2GD-FTV engine]

3100 kg (6834 lb.) [1GD-FTV engine]

Double-cab models: 3050 kg (6724 lb.)

▶ Pre-Runner

Single-cab models: 2850 kg (6283 lb.) [1GD-FTV engine]

2900 kg (6393 lb.) [2GD-FTV engine]

Smart-cab models: 3050 kg (6724 lb.)

Double-cab models: 2980 kg (6570 lb.) [1GD-FTV engine]

3050 kg (6724 lb.) [2GD-FTV engine with automatic transmission]

3100 kg (6834 lb.) [2GD-FTV engine with manual transmission]

The gross vehicle weight is the sum weight of the unloaded vehicle, driver, passengers, luggage, hitch and trailer tongue load. Also included is the weight of any special equipment installed on your vehicle.

*: The weights listed are the values considering installing bull bars.

◆ Gross axle weight

The load on either the front or rear axle resulting from distribution of the gross vehicle weight on both axles must not exceed the following:

▶ 2WD models

Front: 1200 kg (2646 lb.)

Rear: 1750 kg (3858 lb.)

▶ 4WD models and Pre-Runner

Front: 1480 kg (3263 lb.)

Rear: 1700 kg (3748 lb.)

◆ Trailer tongue load

The trailer cargo load should be distributed so that the tongue load is 9 to 11% of the total trailer weight, not exceed the following:

- ▶ 2WD models

250 kg (551 lb.)

- ▶ 4WD models

350 kg (772 lb.)

- ▶ Pre-Runner

280 kg (617 lb.)

(Tongue load/Total trailer weight \times 100 = 9 to 11%)

The total trailer weight and tongue load can be measured with platform scales found at a highway weighing stations, building supply companies, trucking companies, junk yards, etc.

- ① Total trailer weight
- ② Tongue load

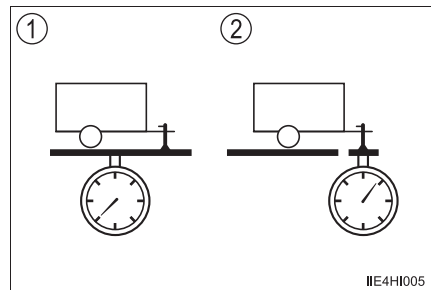

Towing a trailer

Contact your Toyota dealer for further information about additional requirements such as a towing kits etc.

Hitch

Trailer hitch assemblies have different weight capacities established by the hitch manufacturer. Even though the vehicle may be rated for towing a higher weight, the operator must never exceed the maximum weight rating specified for the trailer hitch.

Selecting a trailer ball

Use the correct trailer ball for your application.

① Trailer ball load rating

Matches or exceeds the gross trailer weight rating of the trailer.

② Ball diameter

Matches the size of the trailer coupler. Most couplers are stamped with the required trailer ball size.

③ Shank length

Protrudes beyond the bottom of the lock washer and nut at least 2 threads.

④ Shank diameter

Matches the ball mount hole diameter size.

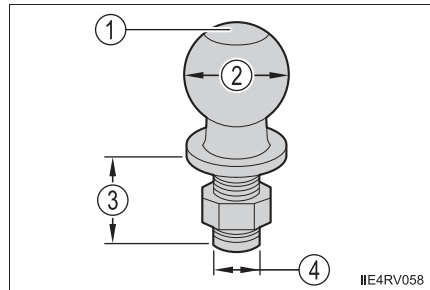

■ Before towing

Check that the following conditions are met:

- The vehicle's tires are properly inflated. (→P. 478)
- Trailer tires are inflated according to the trailer manufacturer's recommendation.
- All trailer lights work.
- All lights work each time you connect them.
- The trailer ball is set up at the proper height for the coupler on the trailer.
- The trailer is level when it is hitched.
Do not drive if the trailer is not level, and check for improper tongue weight, overloading, worn suspension, or other possible causes.
- The trailer cargo is securely loaded.
- The rear view mirrors conform to all applicable federal, state/provincial or local regulations. If they do not, install rear view mirrors appropriate for towing purposes.

■ Break-in schedule

Toyota recommends that you do not use a new vehicle or a vehicle with any new power train components (engine, transmission, differential, wheel bearings, etc.) to tow a trailer for the first 800 km (500 miles) of driving.

■ Maintenance

- If you tow a trailer, your vehicle will require more frequent maintenance due to the additional load. (See "Warranty and Service Booklet".)
- Retighten the fixing bolts of the towing ball and bracket after approximately 1000 km (600 miles) of trailer towing.

■ If trailer sway occurs

One or more factors (crosswinds, passing vehicles, rough roads, etc.) can adversely affect handling of your vehicle and trailer, causing instability.

● If trailer swaying occurs:

- Firmly grip the steering wheel. Steer straight ahead.
Do not try to control trailer swaying by turning the steering wheel.
- Begin releasing the accelerator pedal immediately but very gradually to reduce speed.
Do not increase speed. Do not apply vehicle brakes.

If you make no extreme correction with the steering or brakes, your vehicle and trailer should stabilize (if enabled, Trailer Sway Control can also help to stabilize the vehicle and trailer.).

● After the trailer swaying has stopped:

- Stop in a safe place. Get all occupants out of the vehicle.
- Check the tires of the vehicle and the trailer.
- Check the load in the trailer.
Make sure the load has not shifted.
Make sure the tongue weight is appropriate, if possible.
- Check the load in the vehicle.

Make sure the vehicle is not overloaded after occupants get in.

If you cannot find any problems, the speed at which trailer swaying occurred is beyond the limit of your particular vehicle-trailer combination.

Drive at a lower speed to prevent instability. Remember that swaying of the towing vehicle-trailer increases as speed increases.

 **WARNING****■ To avoid accident or injury**

- The total trailer weight (trailer weight plus the weight of cargo) must not exceed the following:
 - ▶ 2WD models
2500 kg (5512 lb.)
 - ▶ 4WD models
3500 kg (7716 lb.)
 - ▶ Pre-Runner
2800 kg (6173 lb.)
- The gross combined weight (sum of your vehicle weight plus its load and the total trailer weight) must not exceed the following:
 - ▶ 2WD models
Double-cab models: 5250 kg (11574 lb.)
 - ▶ 4WD models
5850 kg (12897 lb.)
 - ▶ Pre-Runner
Single-cab models: 5650 kg (12456 lb.) [2GD-FTV engine]
Smart-cab models: 5650 kg (12456 lb.)
Double-cab models: 5650 kg (12456 lb.)
- Do not exceed the trailer hitch assembly weight, gross vehicle weight, gross axle weight and trailer tongue load capacities.
- Never load more weight in the back than in the front of the trailer. About 60% of the load should be in the front half of the trailer, and the remaining 40% in the rear.

 **WARNING****■ Hitches**

- Use only a hitch that conforms to the total trailer weight requirement.
- Follow the directions supplied by the hitch manufacturer.
- Depending on the type of trailer coupler you use, the trailer ball may need to be coated with grease. If so, apply grease to the trailer ball in accordance with the instructions of the manufacturer of the trailer coupler.
- Remove the hitch ball whenever you are not towing a trailer. Remove the trailer hitch if you do not need it.

■ When towing a trailer

- If the total trailer weight exceeds 750 kg (1653 lb.), trailer brakes are required.
- Never tap into your vehicle's hydraulic system, as this will lower the vehicle's braking effectiveness.
- Never tow a trailer without using a safety chain securely attached to both the trailer and the vehicle. If damage occurs to the coupling unit or hitch ball, there is a risk of the trailer wandering into another lane.

 **NOTICE****■ When installing a trailer hitch**

- Use only the position recommended by your Toyota dealer. Do not install the trailer hitch on the bumper; this may cause body damage.
- Do not use axle-mounted hitches, as they can cause damage to the axle housing, wheel bearings, wheels or tires.

■ Brakes

Toyota recommends trailers with brakes that conform to all applicable federal and state/provincial regulations.

■ Do not directly splice trailer lights

Directly splicing trailer lights may damage your vehicle's electrical system and cause a malfunction.

Trailer towing tips

Your vehicle will handle differently when towing a trailer. In order to avoid accident, death or serious injury, keep the following in mind when towing:

- Before starting out, check the trailer lights and the vehicle-trailer connections. Recheck after driving a short distance.
- Practice turning, stopping and reversing with the trailer attached in an area away from traffic until you become accustomed to the feel of the vehicle.
- Reversing with a trailer attached is difficult and requires practice. Grip the bottom of the steering wheel and move your hand to the left to move the trailer to the left. Move your hand to the right to move the trailer to right. (This is generally opposite to reversing without a trailer attached.) Avoid sharp or prolonged turning. Have someone guide you when reversing to reduce the risk of an accident.
- As stopping distance is increased when towing a trailer, vehicle-to-vehicle distance should be increased. For each 16 km/h (10 mph) of speed, allow at least one vehicle and trailer length.
- Avoid sudden braking as you may skid, resulting in jackknifing and loss of control. This is especially true on wet or slippery surfaces.
- Avoid jerky starts or sudden acceleration.
- Avoid jerky steering and sharp turns, and slow down before making turns.
- Note that when making a turn, the trailer wheels will be closer than the vehicle wheels to the inside of the turn. Compensate by making a larger than normal turning radius.

- Crosswinds and rough roads will adversely affect handling of your vehicle and trailer, causing sway. Periodically check the rear to prepare for being passed by large trucks or buses, which may cause your vehicle and trailer to sway. If swaying occurs, firmly grip the steering wheel, reduce speed immediately but gradually, and steer straight ahead. Never increase speed. If you make no extreme correction with the steering or brakes, your vehicle and trailer will stabilize.
- Take care when passing other vehicles. Passing requires considerable distance. After passing a vehicle, do not forget the length of your trailer, and be sure you have plenty of room before changing lanes.
- Vehicles with manual transmission: To maintain engine braking efficiency and changing system performance when using engine braking, do not use 5th gear (5-speed manual transmission) or 5th gear and 6th gear (6-speed manual transmission).
Vehicles with automatic transmission: To maintain engine braking efficiency and changing system performance when using engine braking, do not use the transmission in D. Transmission shift range position must be in 4 or lower, in S mode.
- Due to the added load of the trailer, your vehicle's engine may overheat on hot days (at temperatures over 30°C [85°F]) when driving up a long or steep grade. If the engine coolant temperature gauge indicates overheating, immediately turn off the air conditioning (if in use), pull your vehicle off the road and stop in a safe spot.
(→P. 459)

- Always place wheel blocks under both the vehicle and the trailer wheels when parking. Apply the parking brake firmly, and put the transmission in P (automatic transmission) or in the 1st or R (manual transmission). Avoid parking on a slope, but if unavoidable, do so only after performing the following:
 - 1 Apply the brakes and keep them applied.
 - 2 Have someone place wheel blocks under both the vehicle and trailer wheels.
 - 3 When the wheel blocks are in place, release the brakes slowly until the blocks absorb the load.
 - 4 Apply the parking brake firmly.
 - 5 Shift into the 1st or R (manual transmission) or P (automatic transmission) and turn off the engine.
- When restarting after parking on a slope:
 - 1 With the transmission in the P position (automatic transmission) or the clutch pedal (manual transmission) depressed, start the engine. On vehicles with automatic transmission, be sure to keep the brake pedal depressed.
 - 2 Shift into 3, 2, 1, or the R position (if reversing).
 - 3 Release the parking brake (also brake pedal on vehicles with automatic transmission), and slowly pull or back away from the wheel blocks. Stop and apply the brakes.
 - 4 Have someone retrieve the blocks.

**WARNING****■ To avoid an accident**

- Observe the legal maximum speeds for trailer towing.
- Slow down and downshift before descending steep or long downhill grades. Do not make sudden downshifts while descending steep or long downhill grades.
- Avoid holding the brake pedal down too long or applying the brakes too frequently. This could cause the brakes to overheat and result in reduced braking efficiency.
- Do not use dynamic radar cruise control when trailer towing.

Engine (ignition) switch (vehicles without smart entry & start system)

Starting the engine

▶ Automatic transmission (gasoline engine)

- 1 Check that the parking brake is set.
- 2 Check that the shift lever is set in P.
- 3 Firmly depress the brake pedal.
- 4 Turn the engine switch to the “START” position to start the engine.

▶ Automatic transmission (diesel engine)

- 1 Check that the parking brake is set.
- 2 Check that the shift lever is set in P.
- 3 Firmly depress the brake pedal.
- 4 Turn the engine switch to the “ON” position.

The  indicator turns on.

- 5 After the  indicator light goes out, turn the engine switch to the “START” position to start the engine.

▶ Manual transmission (gasoline engine)

- 1 Check that the parking brake is set.
- 2 Check that the shift lever is set in N.
- 3 Firmly depress the clutch pedal.
- 4 Turn the engine switch to the “START” position to start the engine.

▶ Manual transmission (diesel engine)

- 1 Check that the parking brake is set.
- 2 Check that the shift lever is set in N.
- 3 Firmly depress the clutch pedal.
- 4 Turn the engine switch to the “ON” position.

The  indicator turns on.

- 5 After the  indicator light goes out, turn the engine switch to the “START” position to start the engine.

Changing the engine switch positions

① “LOCK”

The steering wheel is locked and the key can be removed. (Vehicles with automatic transmission: The key can be removed only when the shift lever is in P.)

② “ACC”

Some electrical components such as the audio system can be used.

③ “ON”

All electrical components can be used.

④ “START”

For starting the engine.

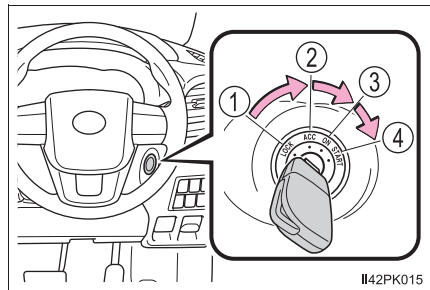

Turning the key from “ACC” to “LOCK”

- 1 Shift the shift lever to P (automatic transmission) or N (manual transmission). (→P. 184, 191)
- 2 Push in the key and turn it to the “LOCK” position.

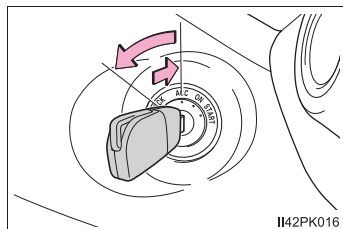

If the engine does not start

The engine immobilizer system may not have been deactivated. (→P. 77)
Contact your Toyota dealer.

■ When the steering lock cannot be released

When starting the engine, the engine switch may seem stuck in the “LOCK” position. To free it, turn the key while turning the steering wheel slightly left and right.

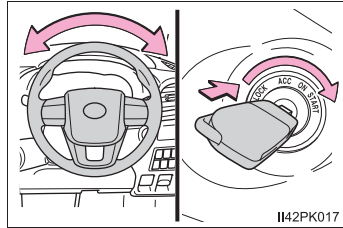

■ Key reminder function

A buzzer sounds if the driver's door is opened while the engine switch is in the “LOCK” or “ACC” position to remind you to remove the key.

⚠ WARNING

■ When starting the engine

Always start the engine while sitting in the driver's seat. Do not depress the accelerator pedal while starting the engine under any circumstances. Doing so may cause an accident resulting in death or serious injury.

■ Caution when driving

Do not turn the engine switch to the “LOCK” position while driving. If in an emergency, you must turn the engine off while the vehicle is moving, turn the engine switch only to the “ACC” position to stop the engine. An accident may result if the engine is stopped while driving. (→P. 411)

⚠ NOTICE

■ To prevent battery discharge

Do not leave the engine switch in the “ACC” or “ON” position for long periods of time without the engine running.

■ When starting the engine

- Do not crank the engine for more than 30 seconds at a time. This may overheat the starter and wiring system.
- Do not race a cold engine.
- If the engine becomes difficult to start or stalls frequently, have your vehicle checked by your Toyota dealer immediately.

Engine (ignition) switch (vehicles with smart entry & start system)

Performing the following operations when carrying the electronic key on your person starts the engine or changes engine switch modes.

Starting the engine

▶ Automatic transmission

- 1 Check that the parking brake is set.
- 2 Check that the shift lever is set in P.
- 3 Firmly depress the brake pedal.

A message will be displayed on the multi-information display. If it is not displayed, the engine cannot be started.

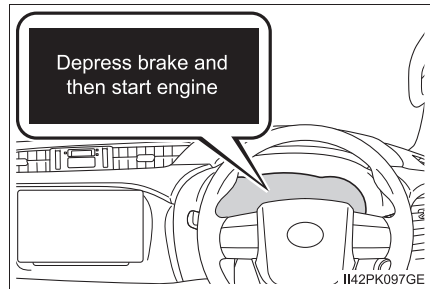

- 4 Press the engine switch shortly and firmly.

When operating the engine switch, one short, firm press is enough. It is not necessary to press and hold the switch.

The engine will crank until it starts or for up to 30 seconds, whichever is less.

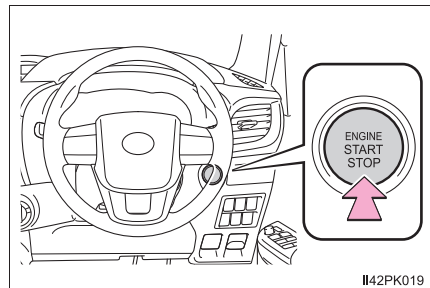

Continue depressing the brake pedal until the engine is completely started.

Diesel engine only: the  indicator turns on. The engine will start after the indicator light goes out.

The engine can be started from any engine switch mode.

► Manual transmission

- 1 Check that the parking brake is set.
- 2 Check that the shift lever is set in N.
- 3 Firmly depress the clutch pedal.

A message will be displayed on the multi-information display. If it is not displayed, the engine cannot be started.

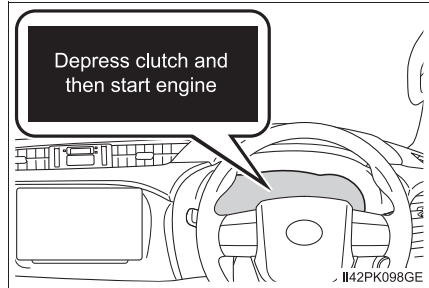

- 4 Press the engine switch shortly and firmly.

When operating the engine switch, one short, firm press is enough. It is not necessary to press and hold the switch.

The engine will crank until it starts or for up to 30 seconds, whichever is less.

Continue depressing the clutch pedal until the engine is completely started.

Diesel engine only: the  indicator turns on. The engine will start after the indicator light goes out.

The engine can be started from any engine switch mode.

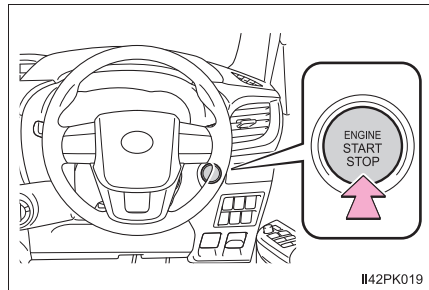

Stopping the engine

▶ Automatic transmission

- 1 Stop the vehicle.
- 2 Set the parking brake (→P. 199), and shift the shift lever to P.
- 3 Press the engine switch.
- 4 Release the brake pedal and check that the display on the instrument cluster is off.

▶ Manual transmission

- 1 Stop the vehicle.
- 2 Shift the shift lever to N.
- 3 Set the parking brake. (→P. 199)
- 4 Press the engine switch.
- 5 Release the brake pedal and check that the display on the instrument cluster is off.

Changing engine switch modes

Modes can be changed by pressing the engine switch with brake pedal (vehicles with automatic transmission) or clutch pedal (vehicles with manual transmission) released. (The mode changes each time the switch is pressed.)

① Off*

The emergency flashers can be used.

② ACCESSORY mode

Some electrical components such as the audio system can be used.

"Accessory mode" will be displayed on the multi-information display.

③ IGNITION ON mode

All electrical components can be used.

"IGNITION ON" will be displayed on the multi-information display.

*: If the shift lever is in a position other than P when turning off the engine, the engine switch will be turned to ACCESSORY mode, not to off (vehicles with automatic transmission only).

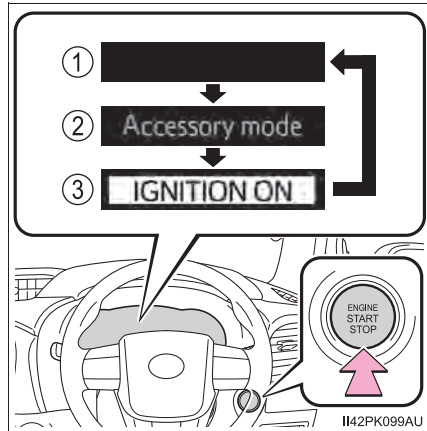

When stopping the engine with the shift lever in a position other than P (vehicles with automatic transmission)

If the engine is stopped with the shift lever in a position other than P, the engine switch will not be turned off but instead be turned to ACCESSORY mode. Perform the following procedure to turn the switch off:

- 1 Check that the parking brake is set.
- 2 Shift the shift lever to P.
- 3 Check that “Turn off vehicle” is displayed on the multi-information display and then press the engine switch once.
- 4 Check that “Turn off vehicle” on the multi-information display is off.

Note for the electronic key

Carry the electronic key on your person, for example in your pocket.

The smart entry & start system does not operate properly if the electronic key is on the floor or the instrument panel, or in the door pockets, cup holders or auxiliary boxes.

Auto power off function**▶ Vehicles with automatic transmission**

If the vehicle is left in ACCESSORY mode for more than 20 minutes or IGNITION ON mode (the engine is not running) for more than an hour with the shift lever in P, the engine switch will automatically turn off. However, this function cannot entirely prevent battery discharge. Do not leave the vehicle with the engine switch in ACCESSORY or IGNITION ON mode for long periods of time when the engine is not running.

▶ Vehicles with manual transmission

If the vehicle is left in ACCESSORY mode for more than 20 minutes or IGNITION ON mode (the engine is not running) for more than an hour, the engine switch will automatically turn off. However, this function cannot entirely prevent battery discharge. Do not leave the vehicle with the engine switch in ACCESSORY or IGNITION ON mode for long periods of time when the engine is not running.

Operation of the engine switch

If the switch is not pressed shortly and firmly, the engine switch mode may not change or the engine may not start.

■ **Electronic key battery depletion**

→P. 125

■ **Conditions affecting operation**

→P. 123

■ **Note for the entry function**

→P. 124

■ **If the engine does not start**

The engine immobilizer system may not have been deactivated. (→P. 77)
Contact your Toyota dealer.

■ **Steering lock**

After turning the engine switch off and opening and closing the doors, the steering wheel will be locked due to the steering lock function. Operating the engine switch again automatically cancels the steering lock.

■ **When the steering lock cannot be released**

A message will be displayed on the multi-information display.

Check that the shift lever is set in P (except manual transmission). Press the engine switch while turning the steering wheel left and right.

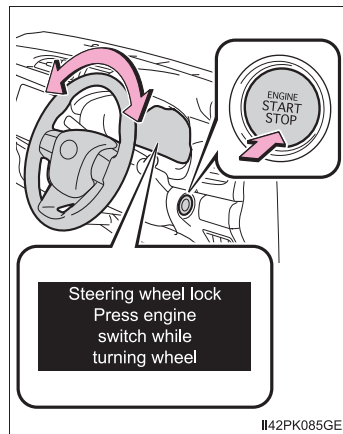

■ **Steering lock motor overheating prevention**

To prevent the steering lock motor from overheating, the motor may be suspended if the engine is turned on and off repeatedly in a short period of time. In this case, refrain from running the engine. After about 10 seconds, the steering lock motor will resume functioning.

■ **If “Smart Entry & Start System malfunction See owner’s manual” is shown on the multi-information display**

The system may be malfunctioning. Have the vehicle inspected by your Toyota dealer immediately.

■ If the electronic key battery is depleted

→P. 373

■ If the smart entry & start system has been deactivated in a customized setting

→P. 450

**WARNING****■ When starting the engine**

Always start the engine while sitting in the driver's seat. Do not depress the accelerator pedal while starting the engine under any circumstances. Doing so may cause an accident resulting in death or serious injury.

■ Caution while driving

If engine failure occurs while the vehicle is moving, do not lock or open the doors until the vehicle reaches a safe and complete stop. Activation of the steering lock in this circumstance may lead to an accident, resulting in death or serious injury.

■ Stopping the engine in an emergency

- If you want to stop the engine in an emergency while driving the vehicle, press and hold the engine switch for more than 2 seconds, or press it briefly 3 times or more in succession. (→P. 411)

However, do not touch the engine switch while driving except in an emergency. If the engine switch is pressed while the vehicle is moving, the warning message "Push and hold engine switch for emergency stop" is displayed on the multi-information display and a buzzer sounds. Turning the engine off while driving will not cause loss of steering or braking control, but the power assist to these systems will be lost. This will make it more difficult to steer and brake, so you should pull over and stop the vehicle as soon as it is safe to do so.

- To restart the engine after turning off the engine while driving, shift the shift lever to N (automatic transmission) or depress the clutch pedal (manual transmission) and then press the engine switch.

**NOTICE****■ To prevent battery discharge**

- Do not leave the engine switch in ACCESSORY or IGNITION ON mode for long periods of time without the engine running.
- If “Accessory mode” or “IGNITION ON” is displayed on the multi-information display while the engine is not running, the engine switch is not off. Exit the vehicle after turning the engine switch off.
- On vehicles with automatic transmission, do not stop the engine when the shift lever is in a position other than P. If the engine is stopped in another shift lever position, the engine switch will not be turned off but instead be turned to ACCESSORY mode. If the vehicle is left in ACCESSORY mode, battery discharge may occur.

■ When starting the engine

- Do not race a cold engine.
- If the engine becomes difficult to start or stalls frequently, have your vehicle checked by your Toyota dealer immediately.

■ Symptoms indicating a malfunction with the engine switch

If the engine switch seems to be operating somewhat differently than usual, such as the switch sticking slightly, there may be a malfunction. Contact your Toyota dealer immediately.

Automatic transmission*

Select a shift position appropriate for the driving conditions.

Shifting the shift lever

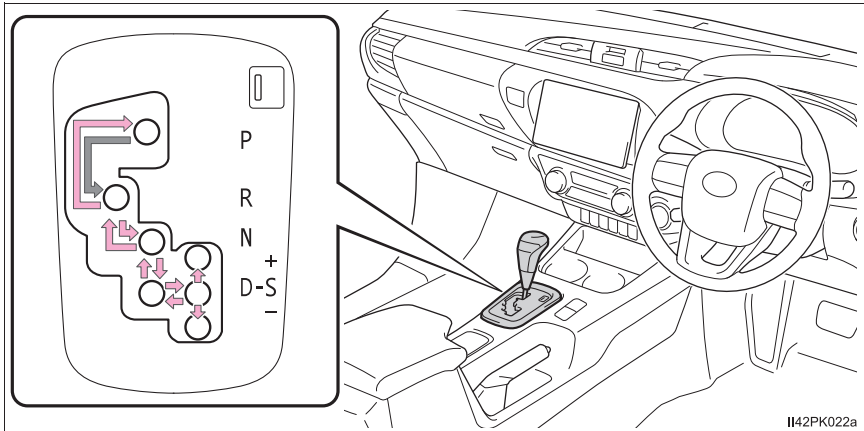

▶ Vehicles without smart entry & start system

- ← While the engine switch is in the “ON” position, move the shift lever with the brake pedal depressed.

When shifting the shift lever between P and D, make sure that the vehicle is completely stopped.

▶ Vehicles with smart entry & start system

- ← While the engine switch is in IGNITION ON mode, move the shift lever with the brake pedal depressed.

When shifting the shift lever between P and D, make sure that the vehicle is completely stopped.

*: If equipped

Shift position purpose

Shift position	Function
P	Parking the vehicle/starting the engine
R	Reversing
N	Neutral (Condition in which the power is not transmitted)
D	Normal driving ^{*1}
S	S mode driving ^{*2} (→P. 187)

*1: To improve fuel efficiency and reduce noises, set the shift lever in the D position for normal driving.

*2: Selecting shift ranges using S mode restricts the upper limit of the possible gear ranges, controls engine braking force, and prevents unnecessary upshifting.

Selecting the driving mode (if equipped)

The driving modes can be selected to suit driving conditions.

① Eco drive mode

Use Eco drive mode to help achieve low fuel consumption during trips that involve frequent accelerating.

Press the “ECO MODE” switch to select Eco drive mode. The “ECO MODE” indicator will come on.

Press the switch again to cancel Eco drive mode, and then the driving mode changes to normal mode for normal driving.

② Power mode

Use when high levels of response and feeling are desirable, such as when driving in mountainous regions or when overtaking.

Press the “PWR MODE” switch to select power mode. The “PWR MODE” indicator will come on.

Press the switch again to cancel power mode, and then the driving mode changes to normal mode for normal driving.

The driving modes cannot be selected when the front-wheel drive control switch is in L4. (if equipped)

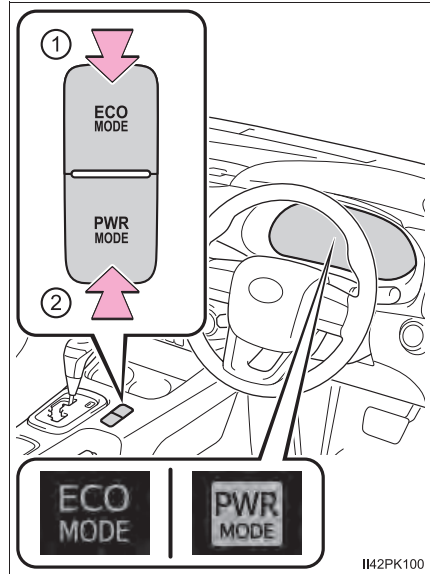

II42PK100

Selecting shift ranges in the S position

To enter S mode, shift the shift lever to S. Shift ranges can be selected by operating the shift lever, allowing you to drive in the shift range of your choosing. The shift range can be selected by the shift lever.

- ① Upshifting
- ② Downshifting

The selected shift range, from 1 to 6, will be displayed in the meter.

The initial shift range in S mode is set automatically to 5 or 4 according to vehicle speed. However, the initial shift range may be set to 3 if AI-SHIFT has operated while the shift lever was in D. (→P. 190)

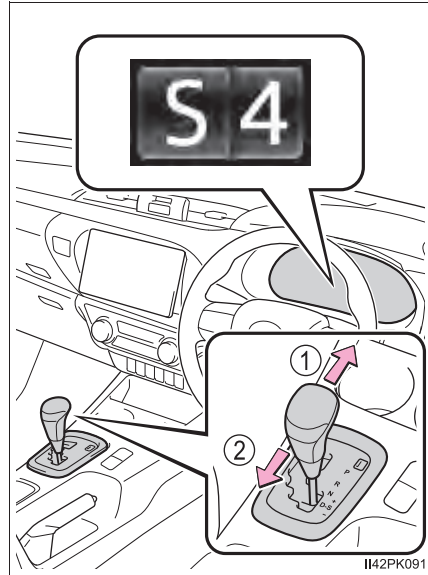

■ Shift ranges and their functions

- Automatically selecting shift ranges between 1 and 6 according to vehicle speed and driving conditions. But the gear is limited according to selected range.
- You can choose from 6 levels of engine braking force.
- A lower shift range will provide greater engine braking force than a higher shift range, and the engine speed will also increase.

■ S mode

When the shift range is 4 or lower, holding the shift lever toward “+” sets the shift range to 6.

■ Downshifting restrictions warning buzzer

To help ensure safety and driving performance, downshifting operation may sometimes be restricted. In some circumstances, downshifting may not be possible even when the shift lever is operated. (A buzzer will sound twice.)

■ Operation of the air conditioning system in Eco drive mode (vehicles with automatic air conditioning system)

Eco drive mode controls the heating/cooling operations and fan speed of the air conditioning system to enhance fuel efficiency (→P. 317). To improve air conditioning performance, adjust the fan speed or turn off Eco drive mode.

■ Deactivation of the driving mode (if equipped)

- Eco drive mode will not be canceled until the “ECO MODE” switch is pressed, even if the engine is turned off after driving in Eco drive mode.
- Power mode will be canceled if the engine is turned off after driving in power mode.
- Driving mode will be canceled if the transfer mode is shifted to L4 while the driving mode is in other than normal mode. (if equipped)

■ When driving with dynamic radar cruise control activated

Even when performing the following actions with the intent of enabling engine braking, engine braking will not activate because dynamic radar cruise control will not be canceled.

- While driving in S mode, downshifting to 5 or 4. (→P. 187)
- When switching the driving mode to power mode while driving in D. (→P. 186)

■ Restraining sudden start (Drive-Start Control)

→P. 151

■ Shift lock system

The shift lock system is a system to prevent accidental operation of the shift lever in starting.

The shift lever can be shifted from P only when the engine switch is in the “ON” position (vehicles without smart entry & start system) or IGNITION ON mode (vehicles with smart entry & start system) and the brake pedal is being depressed.

■ If the shift lever cannot be shifted from P

First, check whether the brake pedal is being depressed.

If the shift lever cannot be shifted with your foot on the brake pedal, there may be a problem with the shift lock system. Have the vehicle inspected by your Toyota dealer immediately.

The following steps may be used as an emergency measure to ensure that the shift lever can be shifted.

Releasing the shift lock:

- 1 Set the parking brake.
- 2 Vehicles without smart entry & start system:
Turn the engine switch to the "LOCK" position.
- Vehicles with smart entry & start system:
Turn the engine switch off.

- 3 Depress the brake pedal.
- 4 Pry the cover up with a flathead screwdriver or equivalent tool.
To prevent damage to the cover, cover the tip of the screwdriver with a rag.

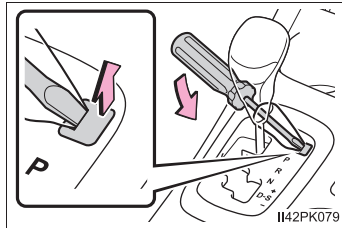

- 5 Press the shift lock override button.
The shift lever can be shifted while the button is pressed.

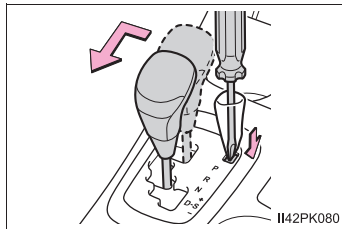

■ If the "S" indicator does not come on or the "D" indicator is displayed even after shifting the shift lever to S

This may indicate a malfunction in the automatic transmission system. Have the vehicle inspected by your Toyota dealer immediately.

■ Transmission protection function

If the tires spin continually when the vehicle becomes stuck in mud, dirt or snow, or if the accelerator pedal is depressed and released repeatedly while driving, the automatic transmission temperature may become too high and the automatic transmission may be damaged.

To avoid damaging the automatic transmission, the system may temporarily lock the gear.

If the automatic transmission temperature falls, the gear locking is canceled and the automatic transmission is returned to the normal operation.

■ If the warning message is displayed

If the automatic transmission fluid temperature warning message is displayed while driving, make sure to return to D position driving and reduce speed by easing off the accelerator pedal. Stop the vehicle in a safe place, shift the shift lever to P and let the engine idle until the warning message goes out.

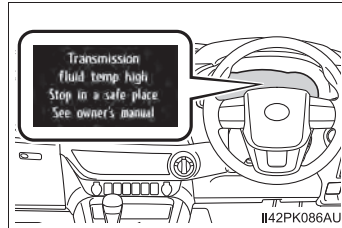

When the warning message goes out, the vehicle can be driven again.

If the warning message does not go out after waiting a while, have your vehicle inspected by your Toyota dealer.

■ AI-SHIFT

The AI-SHIFT automatically selects the suitable gear according to driver performance and driving conditions.

The AI-SHIFT automatically operates when the shift lever is in D. (Shifting the shift lever to S cancels the function.)

**WARNING****■ When driving on slippery road surfaces**

Do not accelerate or shift gears suddenly.

Sudden changes in engine braking may cause the vehicle to spin or skid, resulting in an accident.

■ To prevent an accident when releasing the shift lock

Before pressing the shift lock override button, make sure to set the parking brake and depress the brake pedal.

If the accelerator pedal is accidentally depressed instead of the brake pedal when the shift lock override button is pressed and the shift lever is shifted out of P, the vehicle may suddenly start, possibly leading to an accident resulting in death or serious injury.

Manual transmission*

Shifting the shift lever

► 5-speed transmission

- 1 Depress the clutch pedal firmly.
- 2 Shift the shift lever slowly and securely.
Make sure to only shift gears sequentially.
- 3 Gradually release the clutch pedal.

If it is difficult to shift in R, shift the shift lever to N, release the clutch pedal momentarily, and then try again.

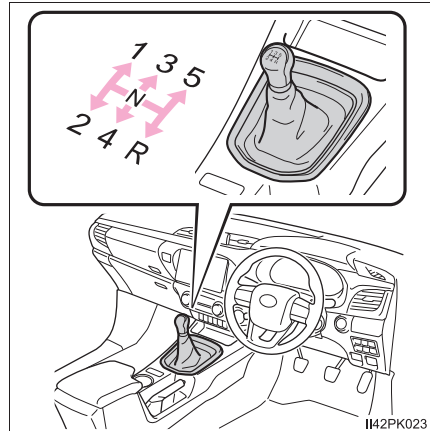

► 6-speed transmission

- 1 Depress the clutch pedal firmly.
- 2 Shift the shift lever slowly and securely.
Make sure to only shift gears sequentially.
- 3 Gradually release the clutch pedal.

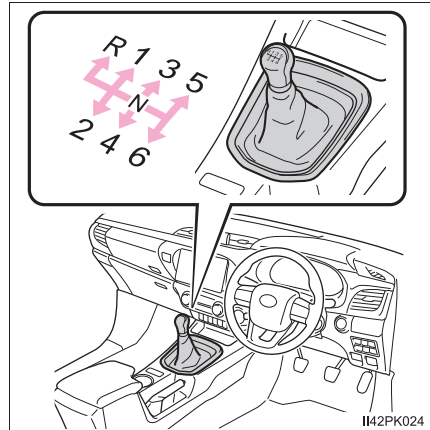

Selecting the driving mode (if equipped)

The driving modes can be selected to suit driving conditions.

① Eco drive mode

Use Eco drive mode to help achieve low fuel consumption during trips that involve frequent accelerating.

Press the “ECO MODE” switch to select Eco drive mode. The “ECO MODE” indicator will come on.

Press the switch again to cancel Eco drive mode, and then the driving mode changes to normal mode for normal driving.

② Power mode

Use when high levels of response and feeling are desirable, such as when driving in mountainous regions or when overtaking.

Press the “PWR MODE” switch to select power mode. The “PWR MODE” indicator will come on.

Press the switch again to cancel power mode, and then the driving mode changes to normal mode for normal driving.

The driving modes cannot be selected when the front-wheel drive control switch is in L4. (if equipped)

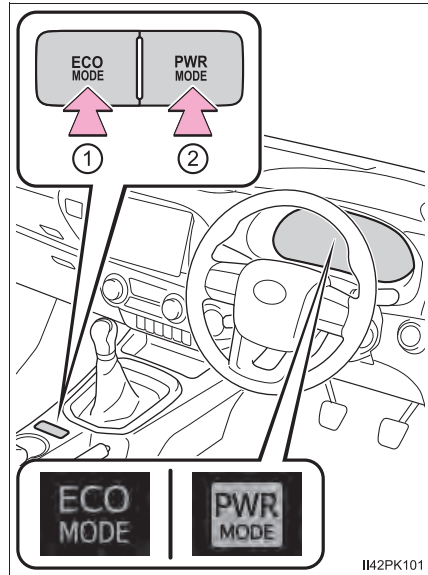

iMT (Intelligent Manual Transmission) (if equipped)

iMT detects clutch pedal and shift lever operations performed by the driver. When the shift position is changed, iMT judges the optimal engine speed and performs the appropriate control to help the driver to change the shift position smoothly.

Press the “iMT” switch.

The “iMT” indicator will come on.

Press the switch again to cancel iMT.

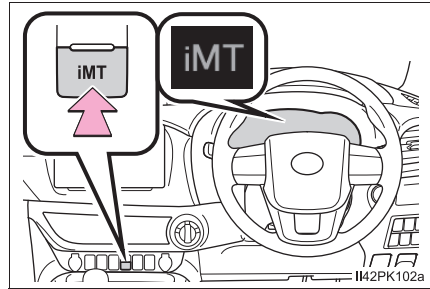

■ Maximum downshifting speeds

Observe the downshifting speeds in the following table to prevent over-revving the engine.

► 5-speed transmission

km/h (mph)

Shift position	Maximum speed			
	1	2	3	4
2TR-FE engine	39 (24)	72 (44)	117 (72)	167 (103)

▶ 6-speed transmission

4WD models (front-wheel drive control switch in H2 or H4): km/h (mph)

Shift position		Maximum speed				
		1	2	3	4	5
1GD-FTV engine	225/70R17C tires	35 (21)	69 (42)	116 (72)	167 (103)	175 (108)
	265/60R18 tires	36 (22)	70 (43)	118 (73)	171 (106)	180 (111)
	265/65R17 tires	36 (22)	70 (43)	118 (73)	170 (105)	180 (111)
2GD-FTV engine	225/70R17C tires	35 (21)	69 (42)	116 (72)	167 (103)	170 (105)
	265/65R17 tires	36 (22)	70 (43)	118 (73)	170 (105)	170 (105)

4WD models (front-wheel drive control switch in L4): km/h (mph)

Shift position		Maximum speed				
		1	2	3	4	5
1GD-FTV engine	225/70R17C tires	14 (8)	27 (16)	45 (27)	65 (40)	79 (49)
	265/60R18 tires	14 (8)	28 (17)	46 (28)	67 (41)	81 (50)
	265/65R17 tires	14 (8)	27 (16)	46 (28)	67 (41)	81 (50)
2GD-FTV engine	225/70R17C tires	14 (8)	27 (16)	45 (27)	65 (40)	84 (52)
	265/65R17 tires	14 (8)	27 (16)	46 (28)	67 (41)	86 (53)

Pre Runner:

km/h (mph)

Shift position		Maximum speed				
		1	2	3	4	5
1GD-FTV engine	225/70R17C tires	35 (21)	69 (42)	116 (72)	167 (103)	175 (108)
	265/60R18 tires	36 (22)	70 (43)	118 (73)	171 (106)	180 (111)
	265/65R17 tires	36 (22)	70 (43)	118 (73)	170 (105)	180 (111)
2GD-FTV engine	225/70R17C tires	35 (21)	69 (42)	116 (72)	167 (103)	170 (105)
	265/65R17 tires	36 (22)	70 (43)	118 (73)	170 (105)	170 (105)

■ Operation of the air conditioning system in Eco drive mode (vehicles with automatic air conditioning system)

Eco drive mode controls the heating/cooling operations and fan speed of the air conditioning system to enhance fuel efficiency (→P. 317). To improve air conditioning performance, adjust the fan speed or turn off Eco drive mode.

■ Deactivation of the driving mode (if equipped)

- Eco drive mode will not be canceled until the “ECO MODE” button is pressed, even if the engine is turned off after driving in Eco drive mode.
- Power mode will be canceled if the engine is turned off after driving in power mode.
- Driving mode will be canceled if the transfer mode is shifted to L4 while the driving mode is in other than normal mode. (if equipped)

■ Reverse warning buzzer (6-speed transmission)

A buzzer will sound to alert the driver if the shift lever is shifted to the R position.

■ Operation of iMT

- When the clutch pedal is depressed and the shift lever is moved to a position, iMT controls the engine speed to be optimal for changing the shift position. However, iMT stops operating before the shift position is changed if the clutch pedal is not released for a while, and the engine speed cannot be controlled. To operate iMT again, depress the clutch pedal and operate the shift lever.
- The engine speed may be increased when the clutch pedal is depressed, however, this does not indicate a malfunction.

■ When iMT does not operate

In the following situations, iMT may not operate. However, this does not indicate a malfunction.

- The shift lever is not operated for a long time after the clutch pedal is depressed.
- The vehicle moves for a while after the shift lever is shifted to N and the clutch pedal is released, and then the clutch pedal is depressed and the shift lever is moved to a position.
- The clutch pedal is not completely released and depressed again.
- The clutch pedal is not fully depressed.

■ If the warning message for iMT is shown on the multi-information display

iMT may be malfunctioning and the function is disabled. Have the vehicle inspected at your Toyota dealer.

 **WARNING****■ Limitations of the iMT**

iMT is not a system that prevents shift lever operation error or engine over-revving. Depending on the situation, iMT may not operate normally and the shift position may not be changed smoothly. Overly relying on iMT may cause an unexpected accident.

 **NOTICE****■ To prevent damage to the vehicle**

- Shift the shift lever to R only when the vehicle is stationary.
- Do not rest your hand on or hold the shift lever any time other than when shifting.
- In order not to cause the engine to overrev, make sure to only shift gears sequentially.
- Do not release the clutch pedal suddenly, as doing so may cause damage to the clutch or transmission.

Turn signal lever

Operating instructions

- ① Left turn
- ② Right turn
- ③ Lane change to the left (move the lever partway and release it)

The left hand signals will flash 3 times.

- ④ Lane change to the right (move the lever partway and release it)

The right hand signals will flash 3 times.

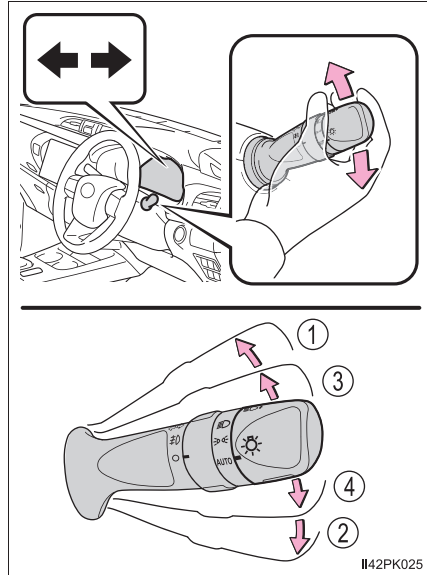

■ Turn signals can be operated when

- ▶ Vehicles without smart entry & start system
The engine switch is in the “ON” position.
- ▶ Vehicles with smart entry & start system
The engine switch is in IGNITION ON mode.

■ If the indicator flashes faster than usual

Check that a light bulb in the front or rear turn signal lights has not burned out.

■ If the turn signals stop flashing before a lane change has been performed

Operate the lever again.

■ To discontinue flashing of the turn signals during a lane change

Operate the lever in the opposite direction.

■ Customization

The number of times the turn signals flash during a lane change can be changed.

(Customizable features: →P. 483)

Parking brake

- ① Sets the parking brake

Fully pull the parking brake while depressing the brake pedal.
At this time, the parking brake indicator light will come on.
- ② Releases the parking brake

Slightly raise the lever and lower it completely while pressing the button.
At this time, the parking brake indicator light will go off.



■ Parking the vehicle

→P. 149

■ Parking brake engaged warning buzzer

→P. 424

■ Usage in winter time

→P. 301

⚠ NOTICE

■ Before driving

Fully release the parking brake.



Driving the vehicle with the parking brake set will lead to brake components overheating, which may affect braking performance and increase brake wear.

Headlight switch

The headlights can be operated manually or automatically.

Operating instructions

Operating the  switch turns on the lights as follows:

- ① **AUTO** The headlights, front position, tail, license plate, instrument panel lights, and daytime running lights (→P. 202) turn on and off automatically (when the engine switch is in the “ON” position [vehicles without smart entry & start system] or IGNITION ON mode [vehicles with smart entry & start system]).
- ②  The front position, tail, license plate and instrument panel lights turn on.
- ③  The headlights and all lights listed above turn on.

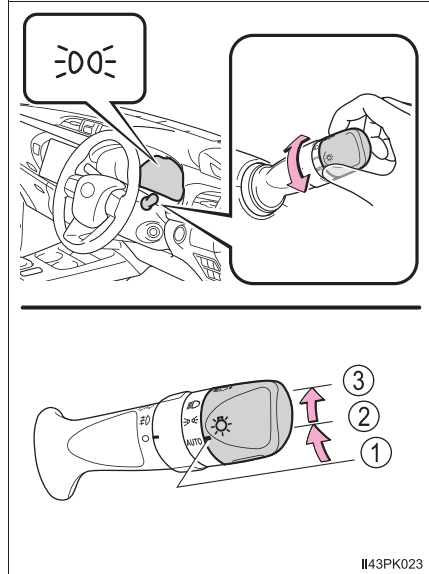

Turning on the high beam headlights

- ① With the headlights on, push the lever away from you to turn on the high beams.

Pull the lever toward you to the center position to turn the high beams off.

- ② Pull the lever toward you and release it to flash the high beams once.

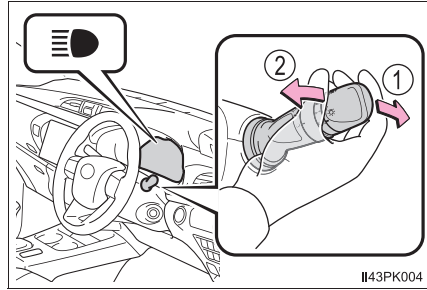

You can flash the high beams with the headlights on or off.

Manual headlight leveling dial (if equipped)

The level of the headlights can be adjusted according to the number of passengers and the loading condition of the vehicle.

- ① Raises the level of the headlights
- ② Lowers the level of the headlights

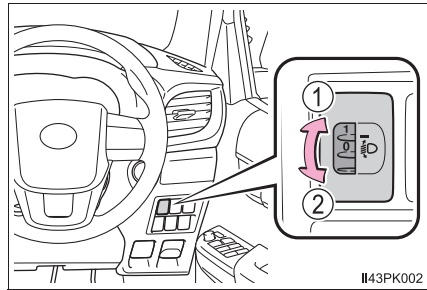

■ Guide to dial settings

Occupancy and luggage load conditions		Dial position		
Occupants	Luggage load	Single-cab models	Smart-cab models	Double-cab models
Driver	None	0	0	0
Driver	Full luggage loading	2	3	2.5 ^{*1} 3 ^{*2}

*1: Halogen headlights type A (→P. 381)

*2: Halogen headlights type B (→P. 381)

Follow me home system

This system allows the headlights and front position lights to be turned on for 30 seconds when the engine switch is turned to the “LOCK” position (vehicles without smart entry & start system) or off (vehicles with smart entry & start system).

Pull the lever toward you and release it with the light switch is in **AUTO** after turning the engine switch to the “LOCK” position (vehicles without smart entry & start system) or off (vehicles with smart entry & start system).

Pull the lever toward you and release it again to turn off the lights.

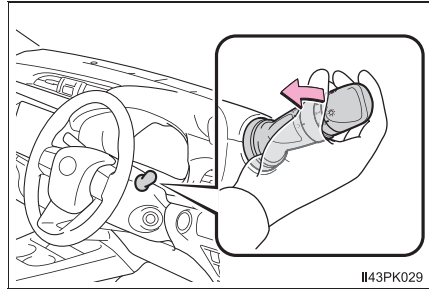

Daytime running light system

To make your vehicle more visible to other drivers during daytime driving, the daytime running lights turn on automatically whenever the engine is started and the parking brake is released with the headlight switch in **AUTO**. (Illuminate brighter than the front position lights.) The daytime running light system is not designed for use at night.

Headlight control sensor

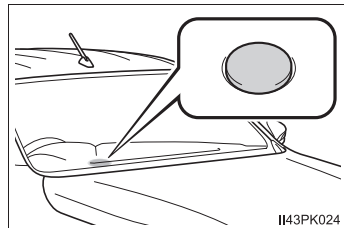

The sensor may not function properly if an object is placed on the sensor, or anything that blocks the sensor is affixed to the windshield.

Doing so interferes with the sensor detecting the level of ambient light and may cause the automatic headlight system to malfunction.



■ Automatic light off system

The lights turn off after the engine switch is turned to the “LOCK” position (vehicles without smart entry & start system) or off (vehicles with smart entry & start system) and the driver’s door is opened.

To turn the lights on again, turn the engine switch to the “ON” position (vehicles without smart entry & start system) or to IGNITION ON mode (vehicles with smart entry & start system), or turn the light switch to  once and then back to  or .

■ Light reminder buzzer (if equipped)

▶ Vehicles without smart entry & start system

A buzzer sounds when the engine switch is turned to the “LOCK” position, the key is removed and the driver’s door is opened while the lights are turned on.

▶ Vehicles with smart entry & start system

A buzzer sounds when the engine switch is turned off and the driver’s door is opened while the lights are turned on.

■ Battery-saving function

In order to prevent the battery of the vehicle from discharging, if the headlights and/or tail lights are on when the engine switch is turned to the “LOCK” position (vehicles without smart entry & start system) or off (vehicles with smart entry & start system), the battery-saving function will operate and automatically turn off all the lights after approximately 20 minutes.

When any of the following are performed, the battery-saving function is canceled once and then reactivated. All the lights will turn off automatically 20 minutes after the battery-saving function has been reactivated:

- When the headlight switch is operated
- When a door is closed once and then opened

■ Automatic headlight leveling system (if equipped)

The level of the headlights is automatically adjusted according to the number of passengers and the loading condition of the vehicle to ensure that the headlights do not interfere with other road users.

■ Customization

Settings (e.g. light sensor sensitivity) can be changed.
(Customizable features: →P. 483)

NOTICE

■ To prevent battery discharge

Do not leave the lights on longer than necessary when the engine is not running.

Fog light switch*

The fog lights secure excellent visibility in difficult driving conditions, such as in rain and fog.

- ① ○ Turns the fog lights off
- ② ☹ Turns the fog lights on

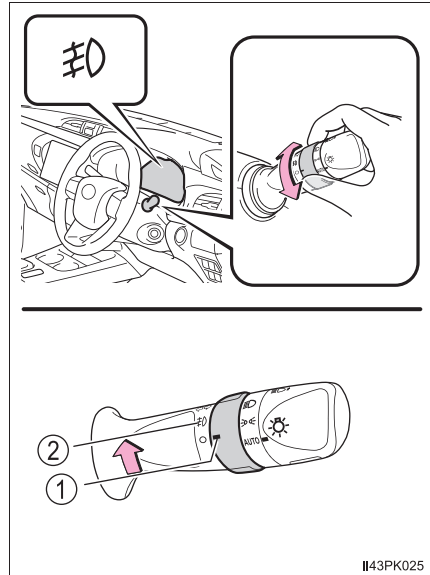

II43PK025

■ Fog lights can be used when

The headlights or front position lights are turned on.

*: If equipped

Windshield wipers and washer

Operating the wiper lever

Operating the  lever operates the wipers or washer as follows.

■ Windshield wipers without intermittent operation

- ① ▼ Low speed operation
- ② ▼ High speed operation
- ③ ▲ Temporary operation

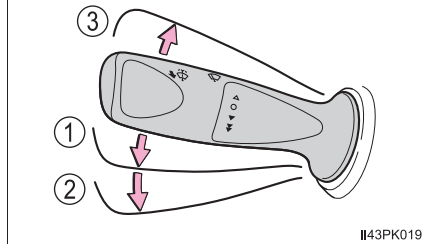
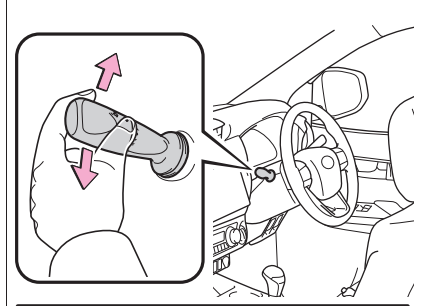



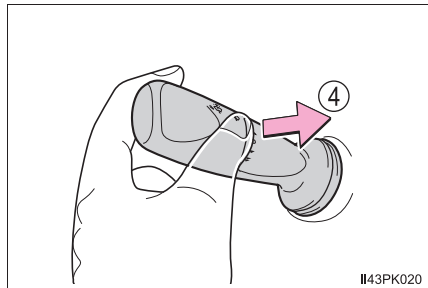

II43PK019

- ④  Washer operation
Pulling the lever operates the washer.



II43PK020

■ Windshield wipers with intermittent operation

- ①  Intermittent operation
- ②  Low speed operation
- ③  High speed operation
- ④  Temporary operation

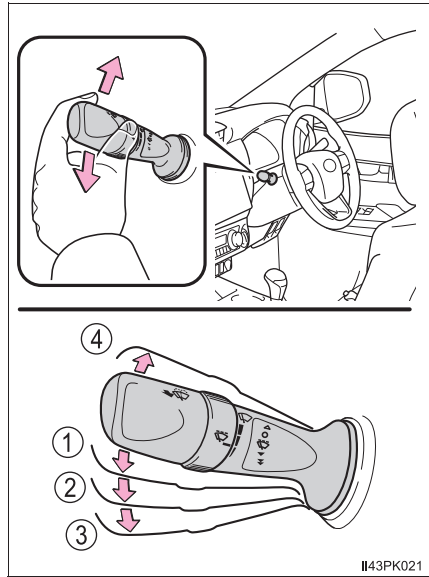

Wiper intervals can be adjusted when intermittent operation is selected.

- ⑤ Increases the intermittent windshield wiper frequency
- ⑥ Decreases the intermittent windshield wiper frequency

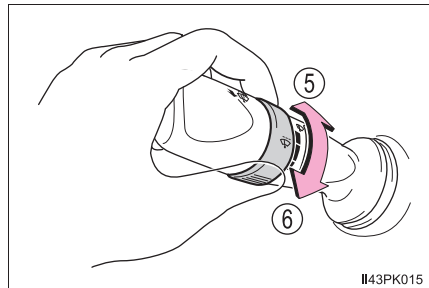

⑦  Washer/wiper dual operation

Pulling the lever operates the wipers and washer.

The wipers will automatically operate a couple of times after the washer squirts.

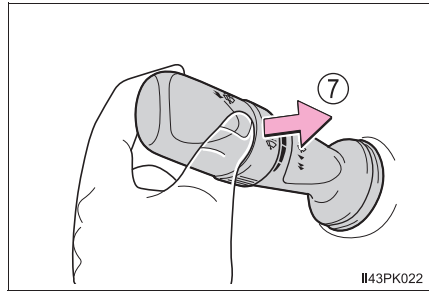

■ **The windshield wipers and washer can be operated when**

The engine switch is in the “ON” position (vehicles without smart entry & start system) or IGNITION ON mode (vehicles with smart entry & start system).

■ **If no windshield washer fluid sprays**

Check that the washer nozzles are not blocked if there is washer fluid in the windshield washer fluid reservoir.

 **WARNING**

■ **Caution regarding the use of washer fluid**

When it is cold, do not use the washer fluid until the windshield becomes warm. The fluid may freeze on the windshield and cause low visibility. This may lead to an accident, resulting in death or serious injury.

 **NOTICE**

■ **When the windshield is dry**

Do not use the wipers, as they may damage the windshield.

■ **When the washer fluid tank is empty**

Do not operate the switch continually as the washer fluid pump may over-heat.

■ **When a nozzle becomes blocked**

In this case, contact your Toyota dealer.

Do not try to clear it with a pin or other object. The nozzle will be damaged.

Opening the fuel tank cap

Perform the following steps to open the fuel tank cap:

Before refueling the vehicle

- Vehicles without smart entry & start system
Turn the engine switch to the “LOCK” position and ensure that all the doors and windows are closed.
- Vehicles with smart entry & start system
Turn the engine switch off and ensure that all the doors and windows are closed.
- Confirm the type of fuel.

■ Fuel types

→P. 481

■ Fuel tank opening for unleaded gasoline (gasoline engine)

To help prevent incorrect fueling, your vehicle has a fuel tank opening that only accommodates the special nozzle on unleaded fuel pumps.

 **WARNING****■ When refueling the vehicle**

Observe the following precautions while refueling the vehicle. Failure to do so may result in death or serious injury.

- After exiting the vehicle and before opening the fuel cap, touch an unpainted metal surface to discharge any static electricity. It is important to discharge static electricity before refueling because sparks resulting from static electricity can cause fuel vapors to ignite while refueling.
- Type A (→P. 210) only: Always hold the grips on the fuel tank cap and turn it slowly to remove it.
A whooshing sound may be heard when the fuel tank cap is loosened. Wait until the sound cannot be heard before fully removing the cap. In hot weather, pressurized fuel may spray out the filler neck and cause injury.
- Do not allow anyone that has not discharged static electricity from their body to come close to an open fuel tank.
- Do not inhale vaporized fuel.
Fuel contains substances that are harmful if inhaled.
- Do not smoke while refueling the vehicle.
Doing so may cause the fuel to ignite and cause a fire.
- Do not return to the vehicle or touch any person or object that is statically charged.
This may cause static electricity to build up, resulting in a possible ignition hazard.

■ When refueling

Observe the following precautions to prevent fuel overflowing from the fuel tank:

- Securely insert the fuel nozzle into the fuel filler neck.
- Stop filling the tank after the fuel nozzle automatically clicks off.
- Do not top off the fuel tank.

 NOTICE

■ Refueling

- Do not spill fuel during refueling.
Doing so may damage the vehicle, such as causing the emission control system to operate abnormally or damaging fuel system components or the vehicle's painted surface.
- Vehicles with DPF system:
Use the specified fuel. If fuel other than the specified fuel is used, white smoke may be continuously emitted from the exhaust pipe during regenerating the filter. (→P. 296)

Opening the fuel tank cap

■ Type A

- 1 Pull up the opener to open the fuel filler door.

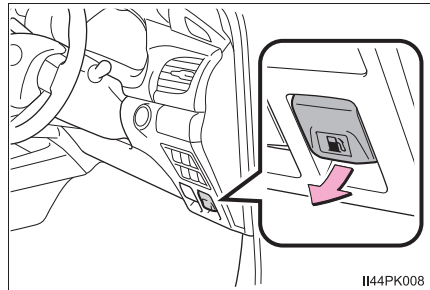

- 2 Turn the fuel tank cap slowly to remove it and hang it on the back of the fuel filler door.

▶ Without over fender

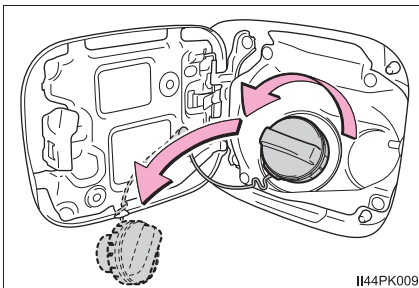

▶ With over fender

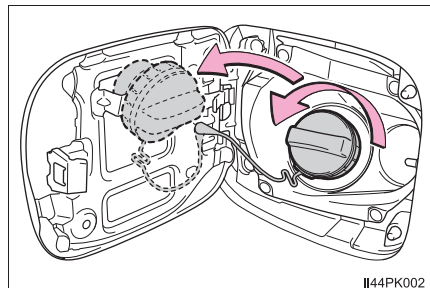

■ Type B

- 1 To unlock the fuel tank cap, insert the key and turn it counterclockwise.

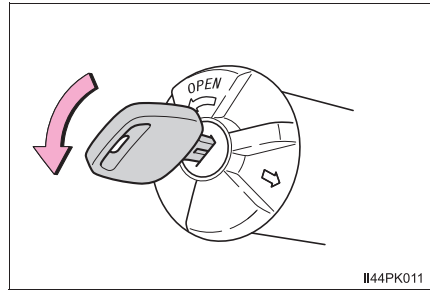

- 2 Turn the fuel tank cap slowly to open. Make sure not to hold and turn the key.

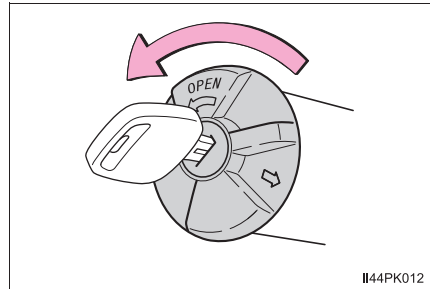

Closing the fuel tank cap

■ Type A

After refueling, turn the fuel tank cap until you hear a click. Once the cap is released, it will turn slightly in the opposite direction.

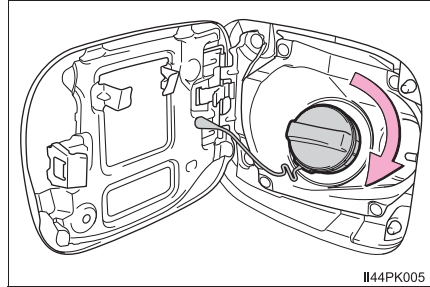

■ Type B

1 Close the fuel tank cap

Make sure to put the fuel tank cap with the arrow upward and turn it slowly to close.

When turning the fuel tank cap, do not hold and turn the key.

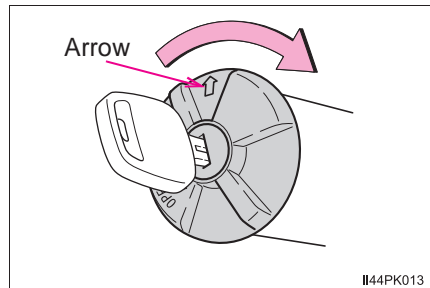

2 Lock the fuel cap

Turning the fuel cap key clockwise.

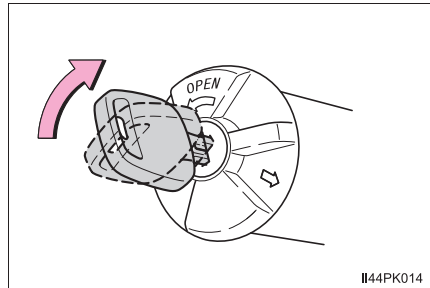

⚠ WARNING

■ When replacing the fuel tank cap

Do not use anything but a genuine Toyota fuel tank cap designed for your vehicle. Doing so may cause a fire or other incident which may result in death or serious injury.

Toyota Safety Sense

The Toyota Safety Sense consists of the following drive assist systems and contributes to a safe and comfortable driving experience:

◆ **PCS (Pre-Collision System)**

→P. 220

◆ **LDA (Lane Departure Alert With Yaw Assist Function)**

→P. 231

◆ **RSA (Road Sign Assist)**

→P. 242

◆ **Dynamic radar cruise control**

→P. 246



WARNING

■ **Toyota Safety Sense**

The Toyota Safety Sense is designed to operate under the assumption that the driver will drive safely, and is designed to help reduce the impact to the occupants and the vehicle in the case of a collision or assist the driver in normal driving conditions.

As there is a limit to the degree of recognition accuracy and control performance that this system can provide, do not overly rely on this system. The driver is always responsible for paying attention to the vehicle's surroundings and driving safely.

Sensors

Two types of sensors, located behind the front grille and windshield, detect information necessary to operate the drive assist systems.

- ① Radar sensor
- ② Front camera

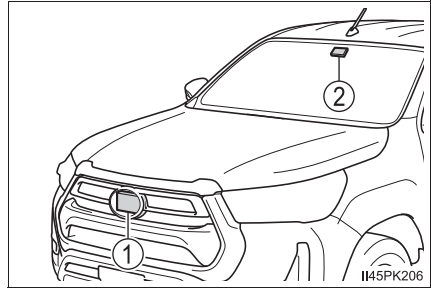

⚠ WARNING

■ To avoid malfunction of the radar sensor

Observe the following precautions.

Otherwise, the radar sensor may not operate properly, possibly leading to an accident resulting in death or serious injury.

- Keep the radar sensor and the radar sensor cover clean at all times.

- ① Radar sensor
- ② Radar sensor cover

If the front of the radar sensor or the front or back of the radar sensor cover is dirty or covered with water droplets, snow, etc., clean it.

Clean the radar sensor and radar sensor cover with a soft cloth to avoid damaging them.

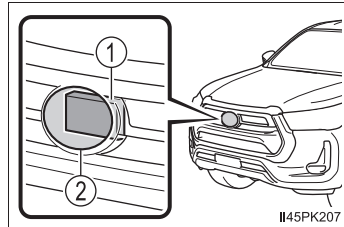

- Do not attach accessories, stickers (including transparent stickers) or other items to the radar sensor, radar sensor cover or surrounding area.
- Do not subject the radar sensor or its surrounding area to a strong impact. If the radar sensor, front grille, or front bumper has been subjected to a strong impact, have the vehicle inspected by your Toyota dealer.
- Do not disassemble the radar sensor.
- Do not modify or paint the radar sensor or radar sensor cover.
- In the following cases, the radar sensor must be recalibrated. Contact your Toyota dealer for details.
 - When the radar sensor or front grille are removed and installed, or replaced
 - When the front bumper is replaced

⚠ WARNING

■ **To avoid malfunction of the front camera**

Observe the following precautions.

Otherwise, the front camera may not operate properly, possibly leading to an accident resulting in death or serious injury.

- Keep the windshield clean at all times.
 - If the windshield is dirty or covered with an oily film, water droplets, snow, etc., clean the windshield.
 - If a glass coating agent is applied to the windshield, it will still be necessary to use the windshield wipers to remove water droplets, etc. from the area of the windshield in front of the front camera.
 - If the inner side of the windshield where the front camera is installed is dirty, contact your Toyota dealer.

- Do not attach objects, such as stickers, transparent stickers, etc., to the outer side of the windshield in front of the front camera (shaded area in the illustration).

A: From the top of the windshield to approximately 1 cm (0.4 in.) below the bottom of the front camera

B: Approximately 20 cm (7.9 in.) (Approximately 10 cm [4.0 in.] to the right and left from the center of the front camera)

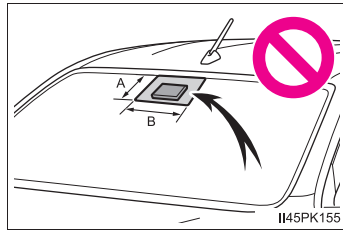

- If the part of the windshield in front of the front camera is fogged up or covered with condensation, or ice, use the windshield defogger to remove the fog, condensation, or ice. (→P. 307, 313)
- If water droplets cannot be properly removed from the area of the windshield in front of the front camera by the windshield wipers, replace the wiper insert or wiper blade.
- Do not attach window tint to the windshield.

 **WARNING**

- Replace the windshield if it is damaged or cracked.
After replacing the windshield, the front camera must be recalibrated. Contact your Toyota dealer for details.
- Do not allow liquids to contact the front camera.
- Do not allow bright lights to shine into the front camera.
- Do not dirty or damage the front camera.
When cleaning the inside of the windshield, do not allow glass cleaner to contact the lens of the front camera. Also, do not touch the lens.
If the lens is dirty or damaged, contact your Toyota dealer.
- Do not subject the front camera to a strong impact.
- Do not change the installation position or direction of the front camera or remove it.
- Do not disassemble the front camera.
- Do not modify any components of the vehicle around the front camera (inside rear view mirror, etc.) or ceiling.
- Do not attach any accessories to the hood, front grille or front bumper that may obstruct the front camera. Contact your Toyota dealer for details.
- If a surfboard or other long object is to be mounted on the roof, make sure that it will not obstruct the front camera.
- Do not modify the headlights or other lights.

■ If a warning message is displayed on the multi-information display

A system may be temporarily unavailable or there may be a malfunction in the system.

- In the following situations, perform the actions specified in the table. When the normal operating conditions are detected, the message will disappear and the system will become operational.

If the message does not disappear, contact your Toyota dealer.

Situation	Actions
When the area around a sensor is covered with dirt, moisture (fogged up, covered with condensation, ice, etc.), or other foreign matter	To clean the part of the windshield in front of the front camera, use the windshield wipers or the windshield defogger of the air conditioning system (→, P. 307, 313).
When the temperature around the front camera is outside of the operational range, such as when the vehicle is in the sun or in an extremely cold environment	<p>If the front camera is hot, such as after the vehicle had been parked in the sun, use the air conditioning system to decrease the temperature around the front camera.</p> <p>If a sunshade was used when the vehicle was parked, depending on its type, the sunlight reflected from the surface of the sunshade may cause the temperature of the front camera to become excessively high.</p>
	If the front camera is cold, such after the vehicle is parked in an extremely cold environment, use the air conditioning system to increase the temperature around the front camera.
The area in front of the front camera is obstructed, such as when the hood is open or a sticker is attached to the part of the windshield in front of the front camera.	Close the hood, remove the sticker, etc. to clear the obstruction.

- In the following situations, if the situation has changed (or the vehicle has been driven for some time) and the normal operating conditions are detected, the message will disappear and the system will become operational.

If the message does not disappear, contact your Toyota dealer.

- When the temperature around the radar sensor is outside of the operational range, such as when the vehicle is in the sun or in an extremely cold environment
- When the front camera cannot detect objects in front of the vehicle, such as when driving in the dark, snow, or fog, or when bright lights are shining into the front camera

PCS (Pre-Collision System)

The pre-collision system uses a radar sensor and front camera to detect objects (→P. 220) in front of the vehicle. When the system determines that the possibility of a frontal collision with an object is high, a warning operates to urge the driver to take evasive action and the potential brake pressure is increased to help the driver avoid the collision. If the system determines that the possibility of a frontal collision with an object is extremely high, the brakes are automatically applied to help avoid the collision or help reduce the impact of the collision.

The pre-collision system can be disabled/enabled and the warning timing can be changed. (→P. 224)

Detectable objects

The system can detect the following:

- Vehicles
- Bicyclists
- Pedestrians

System functions

■ Pre-collision warning

When the system determines that the possibility of a frontal collision is high, a buzzer will sound and a warning message will be displayed on the multi-information display to urge the driver to take evasive action.

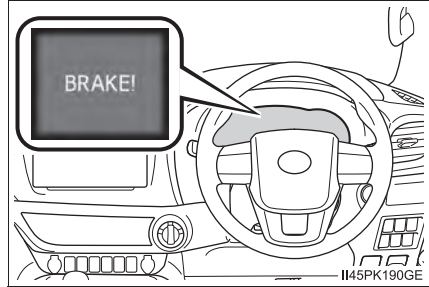

■ Pre-collision brake assist

When the system determines that the possibility of a frontal collision is high, the system applies greater braking force in relation to how strongly the brake pedal is depressed.

■ Pre-collision braking

If the system determines that the possibility of a frontal collision is extremely high, the brakes are automatically applied to help avoid the collision or reduce the impact of the collision.

 **WARNING****■ Limitations of the pre-collision system**

- The driver is solely responsible for safe driving. Always drive safely, taking care to observe your surroundings.
Do not use the pre-collision system instead of normal braking operations under any circumstances. This system will not prevent collisions or lessen collision damage or injury in every situation. Do not overly rely on this system. Failure to do so may lead to an accident, resulting in death or serious injury.
- Although this system is designed to help avoid a collision or help reduce the impact of the collision, its effectiveness may change according to various conditions, therefore the system may not always be able to achieve the same level of performance.
Read the following conditions carefully. Do not overly rely on this system and always drive carefully.
 - Conditions under which the system may operate even if there is no possibility of a collision: →P. 226
 - Conditions under which the system may not operate properly: →P. 228
- Do not attempt to test the operation of the pre-collision system yourself. Depending on the objects used for testing (dummies, cardboard objects imitating detectable objects, etc.), the system may not operate properly, possibly leading to an accident.

■ Pre-collision braking

- When the pre-collision braking function is operating, a large amount of braking force will be applied.
- If the vehicle is stopped by the operation of the pre-collision braking function, the pre-collision braking function operation will be canceled after approximately 2 seconds. Depress the brake pedal as necessary.
- The pre-collision braking function may not operate if certain operations are performed by the driver. If the accelerator pedal is being depressed strongly or the steering wheel is being turned, the system may determine that the driver is taking evasive action and possibly prevent the pre-collision braking function from operating.
- In some situations, while the pre-collision braking function is operating, operation of the function may be canceled if the accelerator pedal is depressed strongly or the steering wheel is turned and the system determines that the driver is taking evasive action.
- If the brake pedal is being depressed, the system may determine that the driver is taking evasive action and possibly delay the operation timing of the pre-collision braking function.

 **WARNING****■ When to disable the pre-collision system**

In the following situations, disable the system, as it may not operate properly, possibly leading to an accident resulting in death or serious injury:

- When the vehicle is being towed
- When your vehicle is towing another vehicle
- When transporting the vehicle via truck, boat, train or similar means of transportation
- When the vehicle is raised on a lift with the engine running and the tires are allowed to rotate freely
- When inspecting the vehicle using a drum tester such as a chassis dynamometer or speedometer tester, or when using an on vehicle wheel balancer
- When a strong impact is applied to the front bumper or front grille, due to an accident or other reasons
- If the vehicle cannot be driven in a stable manner, such as when the vehicle has been in an accident or is malfunctioning
- When the vehicle is driven in a sporty manner or off-road
- When the tires are not properly inflated
- When the tires are very worn
- When tires of a size other than specified are installed
- When tire chains are installed
- When a compact spare tire or an emergency tire puncture repair kit is used
- If equipment (snow plow, etc.) that may obstruct the radar sensor or front camera is temporarily installed to the vehicle

Changing settings of the pre-collision system

■ Enabling/disabling the pre-collision system

The pre-collision system can be enabled/disabled on  (→P. 96) of the multi-information display.

The system is automatically enabled each time the engine switch is turned to the “ON” position (vehicles without smart entry & start system) or IGNITION ON mode (vehicles with smart entry & start system).

If the system is disabled, the PCS warning light will turn on and a message will be displayed on the multi-information display.

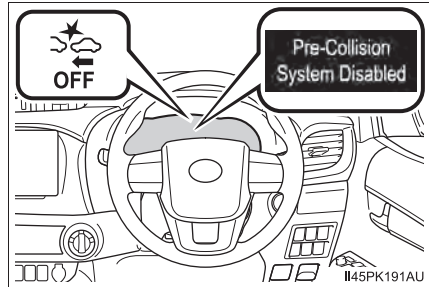

■ Changing the pre-collision warning timing

The pre-collision warning timing can be changed on  (→P. 96) of the multi-information display.

The warning timing setting is retained when the engine switch is turned to the “LOCK” position (vehicles without smart entry & start system) or off (vehicles with smart entry & start system). However, if the pre-collision system is disabled and re-enabled, the operation timing will return to the default setting (middle).

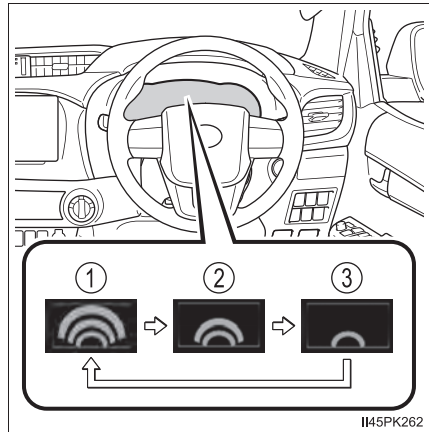

- ① Early
- ② Middle
This is the default setting.
- ③ Late

■ Operational conditions

The pre-collision system is enabled and the system determines that the possibility of a frontal collision with a detected object is high.

Each function is operational at the following speed

● Pre-collision warning

Detectable objects	Vehicle speed	Relative speed between your vehicle and object
Vehicles	Approx. 10 to 180 km/h (7 to 110 mph)	Approx. 10 to 180 km/h (7 to 110 mph)
Bicyclists and pedestrians	Approx. 10 to 80 km/h (7 to 50 mph)	Approx. 10 to 80 km/h (7 to 50 mph)

● Pre-collision brake assist

Detectable objects	Vehicle speed	Relative speed between your vehicle and object
Vehicles	Approx. 30 to 180 km/h (20 to 110 mph)	Approx. 30 to 180 km/h (20 to 110 mph)
Bicyclists and pedestrians	Approx. 30 to 80 km/h (20 to 50 mph)	Approx. 30 to 80 km/h (20 to 50 mph)

● Pre-collision braking

Detectable objects	Vehicle speed	Relative speed between your vehicle and object
Vehicles	Approx. 10 to 180 km/h (7 to 110 mph)	Approx. 10 to 180 km/h (7 to 110 mph)
Bicyclists and pedestrians	Approx. 10 to 80 km/h (7 to 50 mph)	Approx. 10 to 80 km/h (7 to 50 mph)

The system may not operate in the following situations:

- If a battery terminal has been disconnected and reconnected and then the vehicle has not been driven for a certain amount of time
- If the shift lever is in R
- When the VSC OFF indicator is illuminated (only the pre-collision warning function will be operational)

■ Object detection function

The system detects objects based on their size, profile, motion, etc. However, an object may not be detected depending on the surrounding brightness and the motion, posture, and angle of the detected object, preventing the system from operating properly. (→P. 228)

The illustration shows an image of detectable objects.

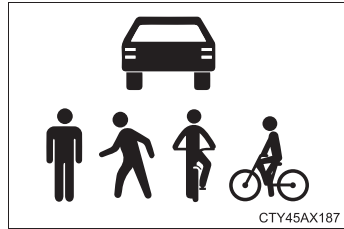

■ Cancellation of the pre-collision braking

If either of the following occur while the pre-collision braking function is operating, it will be canceled:

- The accelerator pedal is depressed strongly.
- The steering wheel is turned sharply or abruptly.

■ Conditions under which the system may operate even if there is no possibility of a collision

● In some situations such as the following, the system may determine that there is a possibility of a frontal collision and operate.

- When passing a detectable object, etc.
- When changing lanes while overtaking a detectable object, etc.
- When approaching a detectable object in an adjacent lane or on the roadside, such as when changing the course of travel or driving on a winding road

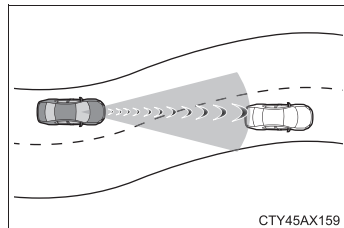

- When rapidly closing on a detectable object, etc.
- When approaching objects on the roadside, such as detectable objects, guardrails, utility poles, trees, or walls
- When there is a detectable object or other object by the roadside at the entrance of a curve

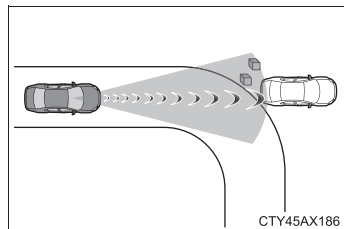

- When there are patterns or paint in front of your vehicle that may be mistaken for a detectable object
- When the front of your vehicle is hit by water, snow, dust, etc.
- When overtaking a detectable object that is changing lanes or making a right/left turn

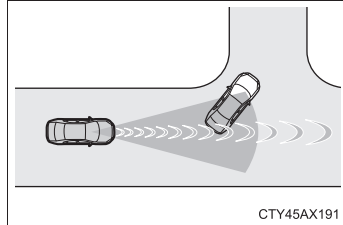

- When passing a detectable object in an oncoming lane that is stopped to make a right/left turn

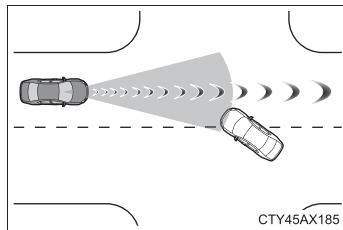

- When a detectable object approaches very close and then stops before entering the path of your vehicle
- If the front of your vehicle is raised or lowered, such as when on an uneven or undulating road surface
- When driving on a road surrounded by a structure, such as in a tunnel or on an iron bridge
- When there is a metal object (manhole cover, steel plate, etc.), steps, or a protrusion in front of your vehicle
- When passing under an object (road sign, billboard, etc.)

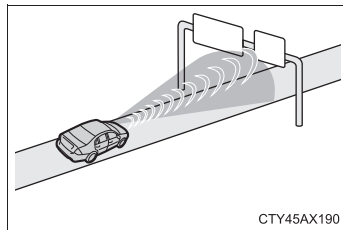

- When approaching an electric toll gate barrier, parking area barrier, or other barrier that opens and closes
- When using an automatic car wash

- When driving through or under objects that may contact your vehicle, such as thick grass, tree branches, or a banner

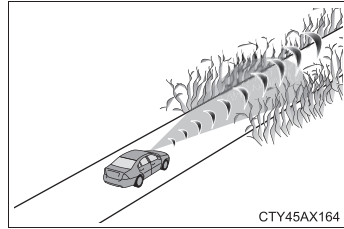

- When driving through steam or smoke
- When driving near an object that reflects radio waves, such as a large truck or guardrail
- When driving near a TV tower, broadcasting station, electric power plant, or other location where strong radio waves or electrical noise may be present

■ Situations in which the system may not operate properly

- In some situations such as the following, an object may not be detected by the radar sensor and front camera, preventing the system from operating properly:

- When a detectable object is approaching your vehicle
- When your vehicle or a detectable object is wobbling
- If a detectable object makes an abrupt maneuver (such as sudden swerving, acceleration or deceleration)
- When your vehicle approaches a detectable object rapidly
- When a detectable object is not directly in front of your vehicle

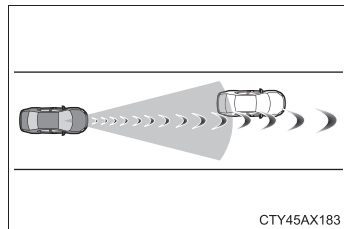

- When a detectable object is near a wall, fence, guardrail, manhole cover, vehicle, steel plate on the road, etc.
- When a detectable object is under a structure
- When part of a detectable object is hidden by an object, such as large baggage, an umbrella, or guardrail
- When multiple detectable objects are close together
- If the sun or other light is shining directly on a detectable object
- When a detectable object is a shade of white and looks extremely bright
- When a detectable object appears to be nearly the same color or brightness as its surroundings
- If a detectable object cuts or suddenly emerges in front of your vehicle
- When the front of your vehicle is hit by water, snow, dust, etc.
- When a very bright light ahead, such as the sun or the headlights of oncoming traffic, shines directly into the front camera
- When approaching the side or front of a vehicle ahead

- If a vehicle ahead is a motorcycle
- If a vehicle ahead is narrow, such as a personal mobility vehicle
- If a preceding vehicle has a small rear end, such as an unloaded truck
- If a preceding vehicle has a low rear end, such as a low bed trailer

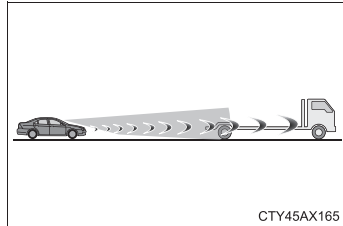

- If a vehicle ahead has extremely high ground clearance

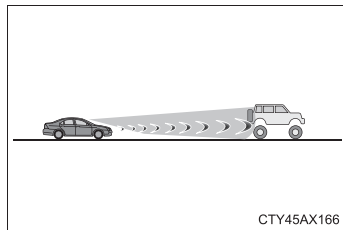

- If a vehicle ahead is carrying a load which protrudes past its rear bumper
- If a vehicle ahead is irregularly shaped, such as a tractor or side car
- If a vehicle ahead is a child sized bicycle, a bicycle that is carrying a large load, a bicycle ridden by more than one person, or a uniquely shaped bicycle (bicycle with a child seat, tandem bicycle, etc.)
- If a pedestrian/or the riding height of a bicyclist ahead is shorter than approximately 1 m (3.2 ft.) or taller than approximately 2 m (6.5 ft.)
- If a pedestrian/bicyclist is wearing oversized clothing (a rain coat, long skirt, etc.), making their silhouette obscure
- If a pedestrian is bending forward or squatting or bicyclist is bending forward
- If a pedestrian/bicyclist is moving fast
- If a pedestrian is pushing a stroller, wheelchair, bicycle or other vehicle
- When driving in inclement weather such as heavy rain, fog, snow or a sandstorm
- When driving through steam or smoke
- When the surrounding area is dim, such as at dawn or dusk, or while at night or in a tunnel, making a detectable object appear to be nearly the same color as its surroundings
- When driving in a place where the surrounding brightness changes suddenly, such as at the entrance or exit of a tunnel
- After the engine has started the vehicle has not been driven for a certain amount of time
- While making a left/right turn and for a few seconds after making a left/right turn
- While driving on a curve and for a few seconds after driving on a curve
- If your vehicle is skidding

- If the front of the vehicle is raised or lowered

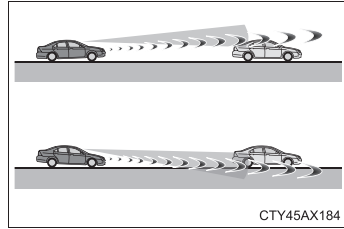

- If the wheels are misaligned
 - If a wiper blade is blocking the front camera
 - The vehicle is being driven at extremely high speeds
 - When driving on a hill
 - If the radar sensor or front camera is misaligned
- In some situations such as the following, sufficient braking force may not be obtained, preventing the system from performing properly:
 - If the braking functions cannot operate to their full extent, such as when the brake parts are extremely cold, extremely hot, or wet
 - If the vehicle is not properly maintained (brakes or tires are excessively worn, improper tire inflation pressure, etc.)
 - When the vehicle is being driven on a gravel road or other slippery surface
- **If VSC is disabled**
- If VSC is disabled (→P. 287), the pre-collision brake assist and pre-collision braking functions are also disabled.
 - The PCS warning light will turn on and “VSC Disabled Pre-Collision Brake System Unavailable” will be displayed on the multi-information display.

LDA (Lane Departure Alert With Yaw Assist Function)

Summary of functions

When driving on highways and freeways with white (yellow) lane lines, this function alerts the driver when the vehicle might depart from its lane or course* and provides assistance by applying a brake force to keep the vehicle in its lane or course*.

The LDA system recognizes white (yellow) lane lines or a course* using the front camera. Additionally, it detects preceding vehicles using the front camera and radar.

*: Boundary between asphalt and the side of the road, such as grass, soil, or a curb

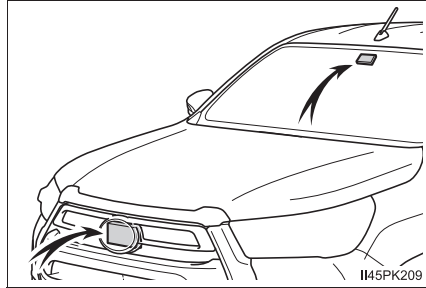

⚠ WARNING

■ Before using LDA system

- Do not rely solely upon the LDA system. The LDA system does not automatically drive the vehicle or reduce the amount of attention that must be paid to the area in front of the vehicle. The driver must always assume full responsibility for driving safely by paying careful attention to the surrounding conditions and operating the steering wheel to correct the path of the vehicle. Also, the driver must take adequate breaks when fatigued, such as from driving for a long period of time.
- Failure to perform appropriate driving operations and pay careful attention may lead to an accident, resulting in death or serious injury.
- When not using the LDA system, use the LDA switch to turn the system off.

 **WARNING****■ Situations unsuitable for LDA system**

In the following situations, use the LDA switch to turn the system off. Failure to do so may lead to an accident, resulting in death or serious injury.

- Vehicle is driven on a road surface which is slippery due to rainy weather, fallen snow, freezing, etc.
- Vehicle is driven on a snow-covered road.
- White (yellow) lines are difficult to see due to rain, snow, fog, dust, etc.
- A spare tire, tire chains, etc. are equipped.
- When the tires have been excessively worn, or when the tire inflation pressure is low.
- When tires of a size other than specified are installed.
- Vehicle is driven in traffic lanes other than that highways and freeways.
- When your vehicle is towing a trailer or during emergency towing.

■ Preventing LDA system malfunctions and operations performed by mistake

- Do not modify the headlights or place stickers, etc. on the surface of the lights.
- Do not modify the suspension etc. If the suspension etc. needs to be replaced, contact your Toyota dealer.
- Do not install or place anything on the hood or grille. Also, do not install a grille guard (bull bars, kangaroo bar, etc.).
- If your windshield needs repairs, contact your Toyota dealer.

⚠ WARNING

■ Conditions in which functions may not operate properly

In the following situations, the functions may not operate properly and the vehicle may depart from its lane. Drive safely by always paying careful attention to your surroundings and operate the steering wheel to correct the path of the vehicle without relying solely on the functions.

- Vehicle is being driven around a sharp curve.
- Objects or patterns that could be mistaken for white (yellow) lines are present on the side of the road (guardrails, reflective poles, etc.).

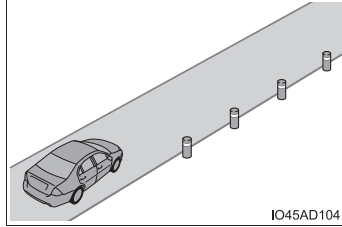

- Vehicle is driven where the road diverges, merges, etc.

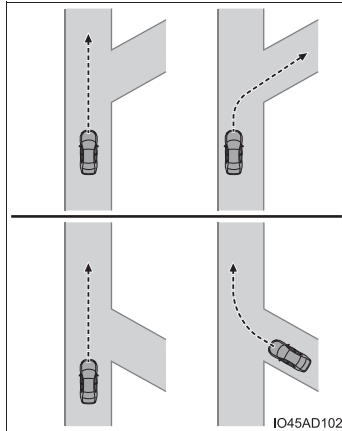

- Repair marks of asphalt, white (yellow) lines, etc. are present due to road repair.

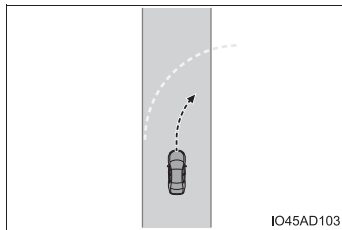

- There are shadows on the road that run parallel with, or cover, the white (yellow) lines.
- The vehicle is driven in an area without white (yellow) lines, such as in front of a tollgate or checkpoint, or at an intersection, etc.

 **WARNING**

- The white (yellow) lines are cracked, “Raised pavement marker” or stones are present.
- The white (yellow) lines cannot be seen or are difficult to see due to sand, etc.
- The vehicle is driven on a road surface that is wet due to rain, puddles, etc.
- The traffic lines are yellow (which may be more difficult to recognize than lines that are white).
- The white (yellow) lines cross over a curb, etc.
- The vehicle is driven on a bright surface, such as concrete.
- If the edge of the road is not clear or straight.
- The vehicle is driven on a surface that is bright due to reflected light, etc.
- The vehicle is driven in an area where the brightness changes suddenly, such as at the entrances and exits of tunnels, etc.
- Light from the headlights of an oncoming vehicle, the sun, etc. enters the camera.
- The vehicle is driven on a slope.
- The vehicle is driven on a road which tilts left or right, or a winding road.
- The vehicle is driven on an unpaved or rough road.
- The traffic lane is excessively narrow or wide.
- The vehicle is extremely tilted due to carrying heavy luggage or having improper tire pressure.
- The distance to the preceding vehicle is extremely short.
- The vehicle is moving up and down a large amount due to road conditions during driving (poor roads or road seams).
- When driving in a tunnel or at night with the headlights off or when a headlight is dim due to its lens being dirty or it being misaligned.
- The vehicle is struck by a crosswind.
- The vehicle has just changed lanes or crossed an intersection.
- Tires which differ by structure, manufacturer, brand or tread pattern are used.
- Snow tires, etc. are equipped.

Functions included in LDA system

■ Lane departure alert function

When the system determines that the vehicle might depart from its lane or course*, a warning is displayed on the multi-information display, and a warning buzzer will sound to alert the driver.

When the warning buzzer sounds, check the area around your vehicle and carefully operate the steering wheel to move the vehicle back to the center of the lane.

*: Boundary between asphalt and the side of the road, such as grass, soil, or a curb

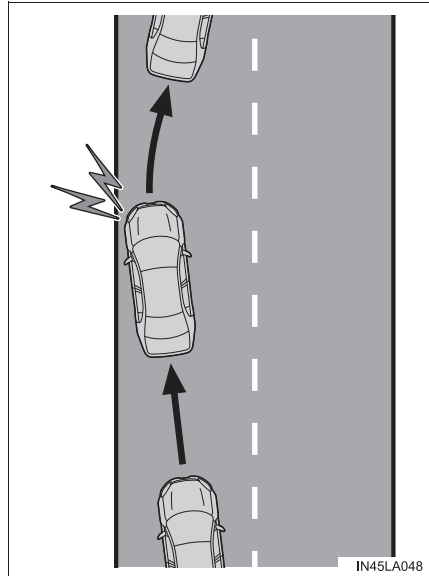

■ Yaw assist function

When the system determines that the vehicle might depart from its lane or course*, the system provides assistance as necessary by applying a brake force for a short period of time to keep the vehicle in its lane.

*: Boundary between asphalt and the side of the road, such as grass, soil, or a curb

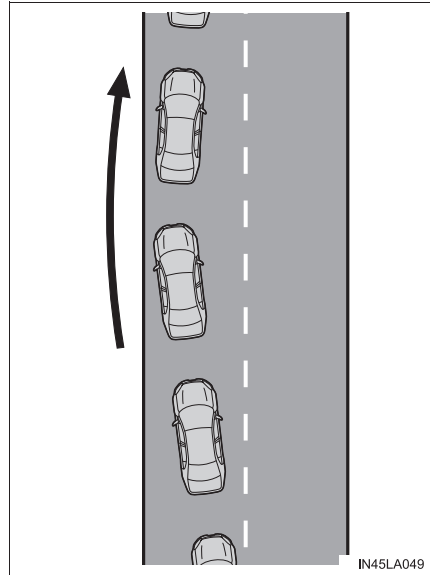

■ Vehicle sway warning function

When the vehicle is swaying within a lane, the warning buzzer will sound and a message will be displayed on the multi-information display to alert the driver.

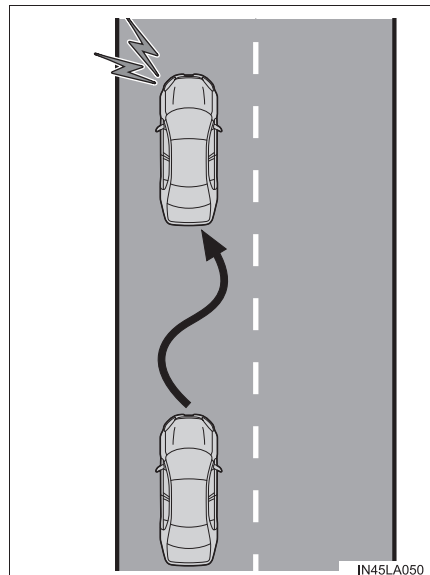

Turning LDA system on

Press the LDA switch to turn the LDA system on.

The LDA indicator illuminates and a message is displayed on the multi-information display.

Press the LDA switch again to turn the LDA system off.

When the LDA system is turned on or off, operation of the LDA system continues in the same condition the next time the engine is started.

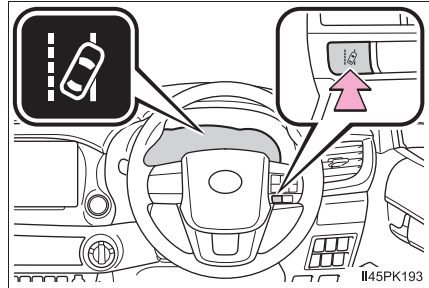

Indications on multi-information display

① LDA indicator

The illumination condition of the indicator informs the driver of the system operation status.

Illuminated in white:
LDA system is operating.

Illuminated in green:
Yaw assist function is operating.

Flashing in yellow: Lane departure alert function is operating.

Illuminated in yellow: Malfunctioning or suspended temporarily.

② Operation display of yaw assist function

Displayed when the multi-information display is switched to the driving support system information screen.

Indicates that yaw assist function is operating.

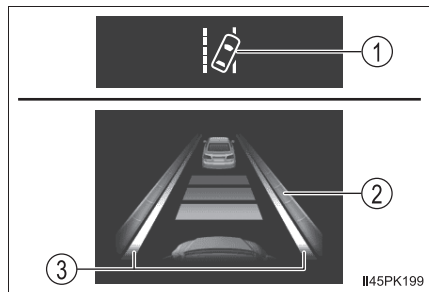

③ Lane departure alert function display

Displayed when the multi-information display is switched to the driving support system information screen.

- ▶ Inside of displayed lines is white
- ▶ Inside of displayed lines is black

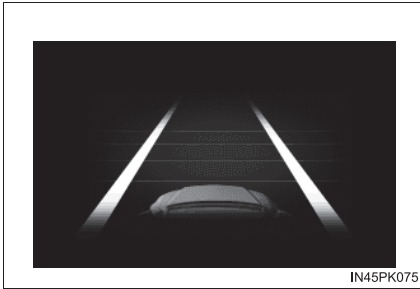

Indicates that the system is recognizing white (yellow) lines or a course*. When the vehicle departs from its lane, the white line displayed on the side the vehicle departs from flashes yellow.



Indicates that the system is not able to recognize white (yellow) lines or a course* or is temporarily canceled.

*: Boundary between asphalt and the side of the road, such as grass, soil, or a curb

■ Operation conditions of each function

● Lane departure alert function

This function operates when all of the following conditions are met.

- LDA is turned on.
- Vehicle speed is approximately 50 km/h (32 mph) or more.
- System recognizes white (yellow) lane lines or a course*. (When a white [yellow] line or course* is recognized on only one side, the system will operate only for the recognized side.)
- Width of traffic lane is approximately 3 m (9.8 ft.) or more.
- Turn signal lever is not operated.
- Vehicle is not being driven around a sharp curve.
- No system malfunctions are detected. (→P. 241)

*: Boundary between asphalt and the side of the road, such as grass, soil, or a curb

● Yaw assist function

This function operates when all of the following conditions are met in addition to the operation conditions for the lane departure alert function.

- Setting for “Yaw Assist” in  of the multi-information display is set to “On” (→P. 92)
- Vehicle is not accelerated or decelerated by a fixed amount or more.
- Steering wheel is not operated with a steering force level suitable for changing lanes.
- ABS, VSC, TRC/A-TRC and PCS are not operating.
- TRC/A-TRC or VSC is not turned off.

● Vehicle sway warning function

This function operates when all of the following conditions are met.

- Setting for “Sway Warning” in  of the multi-information display is set to “On” (→P. 92)
- Vehicle speed is approximately 50 km/h (32 mph) or more.
- Width of traffic lane is approximately 3 m (9.8 ft.) or more.
- No system malfunctions are detected. (→P. 241)

■ Temporary cancelation of functions

When operation conditions are no longer met, a function may be temporarily canceled. However, when the operation conditions are met again, operation of the function is automatically restored. (→P. 239)

■ Yaw assist function

- Depending on the vehicle speed, lane departure situation, road conditions, etc., the driver may not feel the function is operating or the function may not operate at all.
- The yaw assist of the function is overridden by the driver's steering wheel operation.
- Do not attempt to test the operation of the yaw assist function.
- A sound may be heard from the engine compartment when the brake pedal is depressed, when the yaw assist function is operating. This sound does not indicate that a malfunction is occurred in the LDA system.

■ Lane departure alert function

- The warning buzzer may be difficult to hear due to external noise, audio playback, etc.
- If the edge of the course* is not clear or straight, the lane departure alert function may not operate.
- Do not attempt to test the operation of the lane departure alert function.

*: Boundary between asphalt and the side of the road, such as grass, soil, or a curb

■ Vehicle sway warning function

When the system determines that the vehicle is swaying while the vehicle sway warning function is operating, a buzzer sounds and a warning message urging the driver to rest and the symbol shown in the illustration are simultaneously displayed on the multi-information display.



Depending on the vehicle and road conditions, the warning may not operate.

■ Warning message

If the following warning message is displayed on the multi-information display and the LDA indicator illuminates in yellow, follow the appropriate troubleshooting procedure. Also, if a different warning message is displayed, follow the instructions displayed on the screen.

● “LDA Malfunction Visit Your Dealer”

The system may not be operating properly. Have the vehicle inspected by your Toyota dealer.

● “LDA Unavailable”

- The system is temporarily canceled due to a malfunction in a sensor other than the front camera. Turn the LDA system off, wait for a little while, and then turn the LDA system back on.
- The system is temporarily unavailable as the vehicle repeatedly departs from its lane or course* in a short period of time. Turn the engine switch to the “LOCK” position (vehicles without smart entry & start system) or off (vehicles with smart entry & start system), and then turn it to the “ON” position (vehicles without smart entry & start system) or IGNITION ON mode (vehicles with smart entry & start system) again.

*: Boundary between asphalt and the side of the road, such as grass, soil, or a curb

● “LDA Unavailable at Current Speed”

The function cannot be used as the vehicle speed exceeds the LDA operation range. Drive slower.

■ Customization

Function settings can be changed. (Customizable features: →P. 484)

RSA (Road Sign Assist)

Summary of function

The RSA system recognizes specific road signs using the front camera to provide information to the driver via the display.

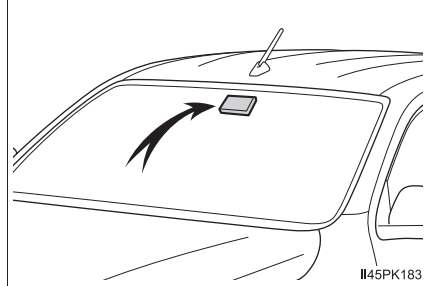

If the system judges that the vehicle is being driven over the speed limit according to the recognized road signs, it notifies the driver through a visual notification and notification buzzer.

WARNING

■ Before using the RSA

Do not rely solely upon the RSA system. RSA is a system which supports the driver by providing information, but it is not a replacement for a driver's own vision and awareness. Drive safely by always paying careful attention to the traffic rules.

Indication on the multi-information display

When the front camera recognizes a sign, the sign will be displayed on the multi-information display.

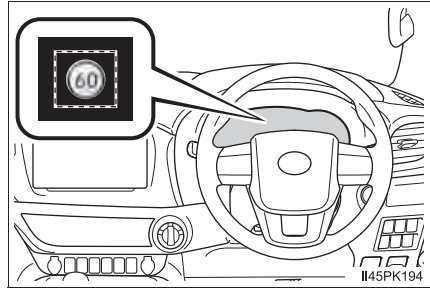

Supported types of road signs

The following types of road signs, including electronic signs and blinking signs, are recognized.

A non-official or a recently introduced traffic sign may not be recognized.



Speed limit



Conditional speed limit sign (School zone)

Notification function

In the following situations, the RSA system will notify the driver.

- When the vehicle speed exceeds the speed notification threshold of the speed limit sign displayed, the sign display will be emphasized and a buzzer will sound.

Depending on the situation, a notification function may not operate properly.

■ Setting procedure

Setting for "RSA" in  of the multi-information display is set to "On" (→P. 96)

■ Automatic turn-off of RSA sign display

In the following situations, a displayed speed limit sign will stop being displayed automatically:

- No sign has been recognized for a certain distance.
- The road changes due to a left or right turn, etc.

■ Conditions in which the function may not operate or detect correctly

In the following situations, RSA does not operate normally and may not recognize signs, display the incorrect sign, etc. However, this does not indicate a malfunction.

- The front camera is misaligned due to a strong impact being applied to the sensor, etc.
- Dirt, snow, stickers, etc. are on the windshield near the front camera.
- In inclement weather such as heavy rain, fog, snow or sand storms.
- Light from an oncoming vehicle, the sun, etc. enters the front camera.
- The sign is dirty, faded, tilted or bent.
- The contrast of electronic sign is low.
- All or part of the sign is hidden by the leaves of a tree, a pole, etc.
- The sign is only visible to the front camera for a short amount of time.
- The driving scene (turning, lane change, etc.) is judged incorrectly.
- If a sign not appropriate for the currently traveled lane, but the sign exists directly after a freeway branches, or in an adjacent lane just before merging.
- Stickers are attached to the rear of the preceding vehicle.
- A sign resembling a system compatible sign is recognized.
- Side road speed signs may be detected and displayed (if positioned in sight of the front camera) while the vehicle is traveling on the main road.
- Roundabout exit road speed signs may be detected and displayed (if positioned in sight of the front camera) while traveling on a roundabout.
- The front of the vehicle is raised or lowered due to the carried load.
- The surrounding brightness is not sufficient or changes suddenly.
- When a sign intended for trucks, etc. is recognized.
- The speed information displayed on the meter and on the navigation system may be different due to the navigation system using map data.

■ Speed limit sign display

If the engine switch was last turned to the “LOCK” position (vehicles without smart entry & start system) or off (vehicles with smart entry & start system) while a speed limit sign was displayed on the multi-information display, the same sign displays again when the engine switch is turned to the “ON” position (vehicles without smart entry & start system) or IGNITION ON mode (vehicles with smart entry & start system).

■ If “RSA Malfunction Visit Your Dealer” is shown

The system may be malfunctioning. Have the vehicle inspected by your Toyota dealer.

■ Customization

Some functions can be customized. (Customizable features: →P. 484)

Dynamic radar cruise control

Summary of functions

In vehicle-to-vehicle distance control mode, the vehicle automatically accelerates and decelerates to match the speed changes of the preceding vehicle even if the accelerator pedal is not depressed. In constant speed control mode, the vehicle runs at a fixed speed.

Use the dynamic radar cruise control on freeways and highways.

- Vehicle-to-vehicle distance control mode (→P. 250)
- Constant speed control mode (→P. 256)

System Components

- ① Indicators
- ② Set speed
- ③ Vehicle-to-vehicle distance switch
- ④ Multi-information display
- ⑤ Cruise control switch

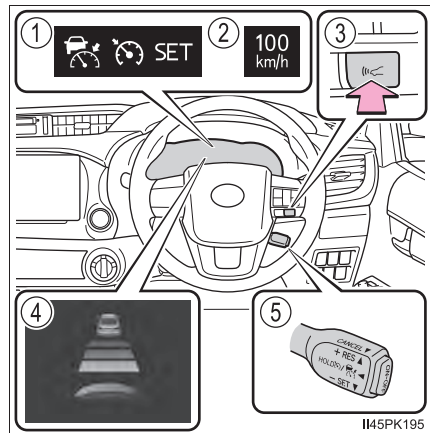

 **WARNING****■ Before using dynamic radar cruise control**

- Driving safely is the sole responsibility of the driver. Do not rely solely on the system, and drive safely by always paying careful attention to your surroundings.
- The dynamic radar cruise control provides driving assistance to reduce the driver's burden. However, there are limitations to the assistance provided. Read the following conditions carefully. Do not overly rely on this system and always drive carefully.
 - When the sensor may not be correctly detecting the vehicle ahead:
→P. 260
 - Conditions under which the vehicle-to-vehicle distance control mode may not function correctly: →P. 261
- Set the speed appropriately depending on the speed limit, traffic flow, road conditions, weather conditions, etc. The driver is responsible for checking the set speed.
- Even when the system is functioning normally, the condition of the preceding vehicle as detected by the system may differ from the condition observed by the driver. Therefore, the driver must always remain alert, assess the danger of each situation and drive safely. Relying solely on this system or assuming the system ensures safety while driving can lead to an accident, resulting in death or serious injury.
- Switch the dynamic radar cruise control setting to off, using the "ON-OFF" button when not in use.

 **WARNING****■ Cautions regarding the driving assist systems**

Observe the following precautions, as there are limitations to the assistance provided by the system. Failure to do so may cause an accident resulting in death or serious injury.

● Assisting the driver to measure following distance

The dynamic radar cruise control is only intended to help the driver in determining the following distance between the driver's own vehicle and a designated vehicle traveling ahead. It is not a mechanism that allows careless or inattentive driving, and it is not a system that can assist the driver in low-visibility conditions.

It is still necessary for driver to pay close attention to the vehicle's surroundings.

● Assisting the driver to judge proper following distance

The dynamic radar cruise control determines whether the following distance between the driver's own vehicle and a designated vehicle traveling ahead is within a set range. It is not capable of making any other type of judgement. Therefore, it is absolutely necessary for the driver to remain vigilant and to determine whether or not there is a possibility of danger in any given situation.

● Assisting the driver to operate the vehicle

The dynamic radar cruise control does not include functions which will prevent or avoid collisions with vehicles ahead of your vehicle. Therefore, if there is ever any possibility of danger, the driver must take immediate and direct control of the vehicle and act appropriately in order to ensure the safety of all involved.

 **WARNING****■ Situations unsuitable for dynamic radar cruise control**

Do not use dynamic radar cruise control in any of the following situations. Doing so may result in inappropriate speed control and could cause an accident resulting in death or serious injury.

- Roads where there are pedestrians, cyclists, etc.
- In heavy traffic
- On roads with sharp bends
- On winding roads
- On slippery roads, such as those covered with rain, ice or snow
- On steep downhills, or where there are sudden changes between sharp up and down gradients
Vehicle speed may exceed the set speed when driving down a steep hill.
- At entrances to freeways and highways
- When weather conditions are bad enough that they may prevent the sensors from detecting correctly (fog, snow, sandstorm, heavy rain, etc.)
- When there is rain, snow, etc. on the front surface of the radar or front camera
- In traffic conditions that require frequent repeated acceleration and deceleration
- When your vehicle is towing a trailer or during emergency towing
- When an approach warning buzzer is heard often

Driving in vehicle-to-vehicle distance control mode

This mode employs a radar to detect the presence of vehicles up to approximately 100 m (328 ft.) ahead, determines the current vehicle-to-vehicle following distance, and operates to maintain a suitable following distance from the vehicle ahead. The desired vehicle-to-vehicle distance can also be set by operating the vehicle-to-vehicle distance switch.

When driving on downhill slopes, the vehicle-to-vehicle distance may become shorter.

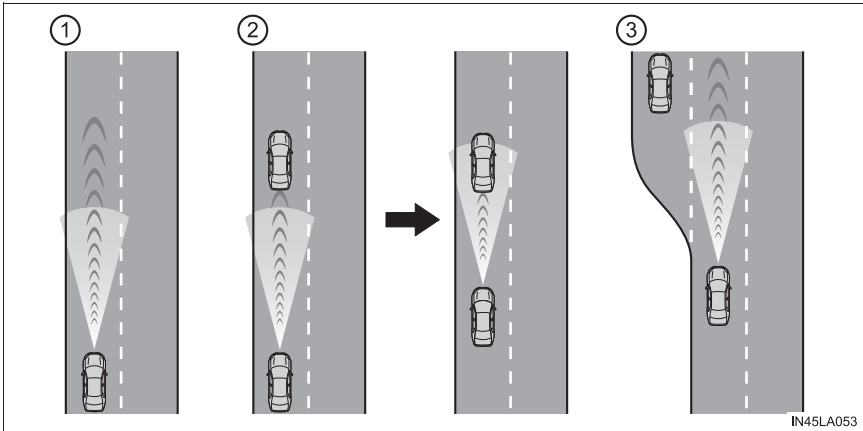

① Example of constant speed cruising

When there are no vehicles ahead

The vehicle travels at the speed set by the driver.

② Example of deceleration cruising and follow-up cruising

When a preceding vehicle driving slower than the set speed appears

When a vehicle is detected running ahead of you, the system automatically decelerates your vehicle. When a greater reduction in vehicle speed is necessary, the system applies the brakes (the stop lights will come on at this time). The system will respond to changes in the speed of the vehicle ahead in order to maintain the vehicle-to-vehicle distance set by the driver. Approach warning warns you when the system cannot decelerate sufficiently to prevent your vehicle from closing in on the vehicle ahead.

When the turn signal lever is operated and your vehicle moves to an overtaking lane while driving at 80 km/h (50 mph) or more, the vehicle will accelerate to help to overtake a passing vehicle.

The system's identification of what is an overtaking lane may be determined solely based on the location of the steering wheel in the vehicle (left side driver position versus right side driver position.) If the vehicle is driven to a region where the overtaking lane is on a different side from where the vehicle is normally driven, the vehicle may accelerate when the turn signal lever is operated in the opposite direction to the overtaking lane (e.g., if the driver normally operates the vehicle in a region where the overtaking lane is to the right but then drives to a region where the overtaking lane is to the left, the vehicle may accelerate when the right turn signal is activated).

③ Example of acceleration

When there are no longer any preceding vehicles driving slower than the set speed

The system accelerates until the set speed is reached. The system then returns to constant speed cruising.

Setting the vehicle speed (vehicle-to-vehicle distance control mode)

- 1 Press the “ON-OFF” button to activate the cruise control.

Dynamic radar cruise control indicator will come on and a message will be displayed on the multi-information display. Press the button again to deactivate the cruise control.

If the “ON-OFF” button is pressed and held for 1.5 seconds or more, the system turns on in constant speed control mode. (→P. 256)

- 2 Accelerate or decelerate, with accelerator pedal operation, to the desired vehicle speed (at or above approximately 30 km/h [20 mph]) and push the lever down to set the speed.

Cruise control “SET” indicator will come on.

The vehicle speed at the moment the lever is released becomes the set speed.

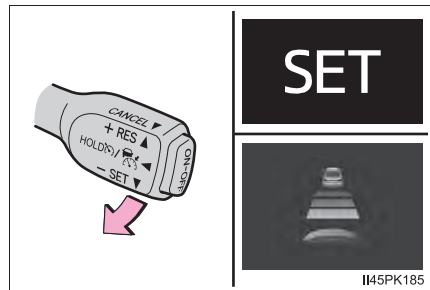
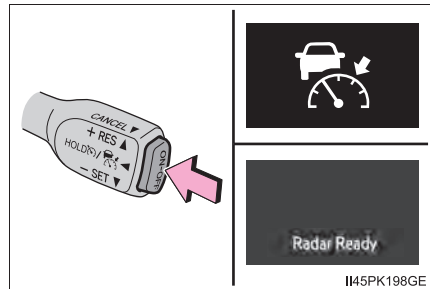

Adjusting the set speed

● Adjusting the set speed by the lever

To change the set speed, operate the lever until the desired set speed is displayed.

① Increases the speed

② Decreases the speed

Fine adjustment: Momentarily move the lever in the desired direction.

Large adjustment: Hold the lever up or down to change the speed, and release when the desired speed is reached.

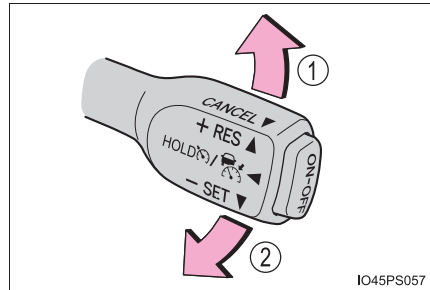

In the vehicle-to-vehicle distance control mode, the set speed will be increased or decreased as follows:

Fine adjustment: By 1 km/h (0.6 mph)^{*1} or 1 mph (1.6 km/h)^{*2} each time the lever is operated

Large adjustment: Increases or decreases in 5 km/h (3.1 mph)^{*1} or 5 mph (8 km/h)^{*2} increments for as long as the lever is held

In the constant speed control mode (→P. 256), the set speed will be increased or decreased as follows:

Fine adjustment: By 1 km/h (0.6 mph)^{*1} or 1 mph (1.6 km/h)^{*2} each time the lever is operated

Large adjustment: The speed will continue to change while the lever is held.

*1: When the set speed is shown in “km/h”

*2: When the set speed is shown in “MPH”

● Increasing the set speed by the accelerator pedal (for diesel engine)

① Accelerate with accelerator pedal operation to the desired vehicle speed

② Push the lever down

Changing the vehicle-to-vehicle distance (vehicle-to-vehicle distance control mode)

Pressing the switch changes the vehicle-to-vehicle distance as follows:

- ① Long
- ② Medium
- ③ Short

The vehicle-to-vehicle distance is set automatically to long mode when the engine switch is turned to the "ON" position (vehicles without smart entry & start system) or IGNITION ON mode (vehicles with smart entry & start system).

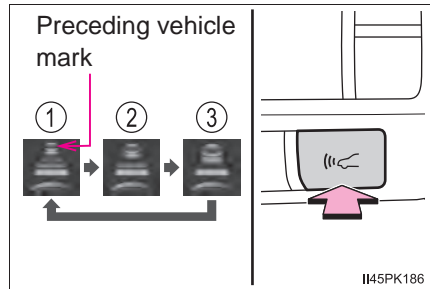

Vehicle-to-vehicle distance settings (vehicle-to-vehicle distance control mode)

Select a distance from the table below. Note that the distances shown correspond to a vehicle speed of 80 km/h (50 mph). Vehicle-to-vehicle distance increases/decreases in accordance with vehicle speed.

Distance options	Vehicle-to-vehicle distance
Long	Approximately 50 m (160 ft.)
Medium	Approximately 40 m (130 ft.)
Short	Approximately 30 m (100 ft.)

Canceling and resuming the speed control

- ① Pulling the lever toward you cancels the speed control.
The speed control is also canceled when the brake pedal is depressed.
- ② Pushing the lever up resumes the cruise control and returns vehicle speed to the set speed.

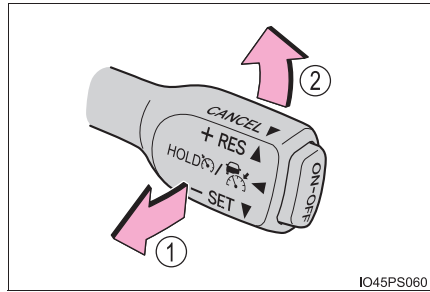

ID45PS060

However, cruise control does not resume when the vehicle speed is approximately 25 km/h (16 mph) or less.

Approach warning (vehicle-to-vehicle distance control mode)

When your vehicle is too close to a vehicle ahead, and sufficient automatic deceleration via the cruise control is not possible, the display will flash and the buzzer will sound to alert the driver. An example of this would be if another driver cuts in front of you while you are following a vehicle. Depress the brake pedal to ensure an appropriate vehicle-to-vehicle distance.

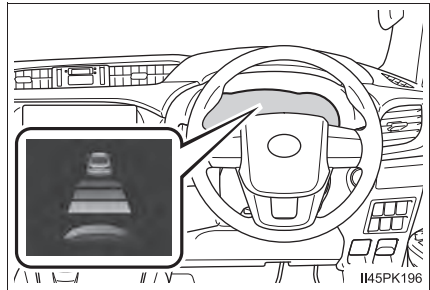

■ Warnings may not occur when

In the following instances, warnings may not occur even when the vehicle-to-vehicle distance is small.

- When the speed of the preceding vehicle matches or exceeds your vehicle speed
- When the preceding vehicle is traveling at an extremely slow speed
- Immediately after the cruise control speed was set
- When depressing the accelerator pedal

Selecting constant speed control mode

When constant speed control mode is selected, your vehicle will maintain a set speed without controlling the vehicle-to-vehicle distance. Select this mode only when vehicle-to-vehicle distance control mode does not function correctly due to a dirty radar, etc.

- 1 With the cruise control off, press and hold the “ON-OFF” button for 1.5 seconds or more.

Immediately after the “ON-OFF” button is pressed, the dynamic radar cruise control indicator will come on. Afterwards, it switches to the cruise control indicator.

Switching to constant speed control mode is only possible when operating the lever with the cruise control off.

- 2 Accelerate or decelerate, with accelerator pedal operation, to the desired vehicle speed (at or above approximately 30 km/h [20 mph]) and push the lever down to set the speed.

Cruise control “SET” indicator will come on.

The vehicle speed at the moment the lever is released becomes the set speed.

Adjusting the speed setting: →P. 253

Canceling and resuming the speed setting: →P. 255

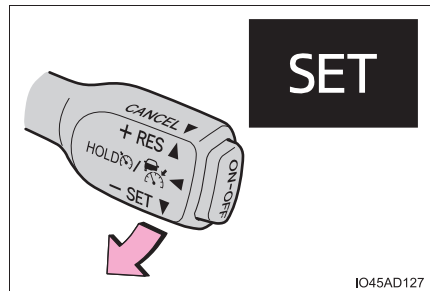
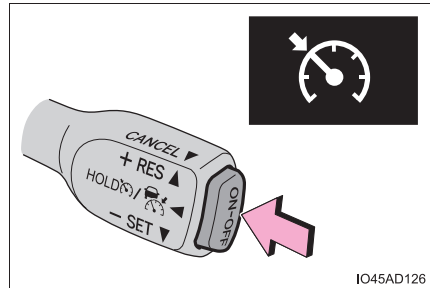

Dynamic Radar Cruise Control with Road Sign Assist

When this function is enabled and the system is operating in vehicle-to-vehicle distance control mode (→P. 250), when a speed limit sign is detected, the recognized speed limit will be displayed with an up/down arrow. The set speed can be increased/reduced to the recognized speed limit by pushing the lever up or down.

- When the current set speed is lower than the recognized speed limit

Push the lever up

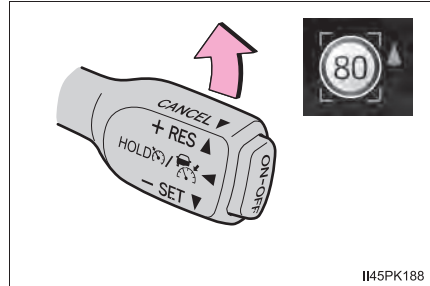

- When the current set speed is higher than the recognized speed limit

Push the lever down

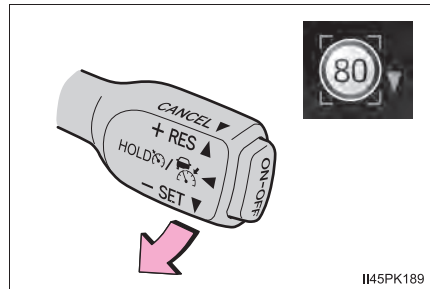

Enabling/Disabling the Dynamic Radar Cruise Control with Road Sign Assist

Dynamic Radar Cruise Control with Road Sign Assist can be enabled/

disabled in  on the multi-information display. (→P. 92)

■ Dynamic radar cruise control can be set when

- The shift lever is in D. (Vehicles with automatic transmission)
- The shift lever is in range 2nd or higher. (Vehicles with manual transmission)
- Depending on the control mode, this item can be set at the following speeds.
 - Vehicle-to-vehicle distance control mode: Approximately 30 km/h (20 mph) or more
 - Constant speed control mode: Approximately 30 km/h (20 mph) or more

■ Accelerating after setting the vehicle speed

The vehicle can accelerate by operating the accelerator pedal. After accelerating, the set speed resumes. However, during vehicle-to-vehicle distance control mode, the vehicle speed may decrease below the set speed in order to maintain the distance to the preceding vehicle.

■ Shift position selection (vehicles with manual transmission)

Select a shift position according to the vehicle speed. If the engine speed is too high or too low, control may be automatically canceled.

■ Automatic cancelation of vehicle-to-vehicle distance control mode

Vehicle-to-vehicle distance control mode is automatically canceled in the following situations.

- Actual vehicle speed falls below approximately 25 km/h (16 mph).
- VSC is activated.
- TRC/A-TRC is activated for a period of time.
- When the VSC or TRC/A-TRC system is turned off.
- The sensor cannot detect correctly because it is covered in some way.
- Pre-collision braking is activated.
- When the shift lever is in N or the clutch pedal is depressed for a certain amount of time or more. (Vehicles with manual transmission)
- 4WD models: Switching the transfer mode is not completed within 5 seconds while the cruise control system is on.

If vehicle-to-vehicle distance control mode is automatically canceled for any reasons other than the above, there may be a malfunction in the system. Contact your Toyota dealer.

■ Automatic cancelation of constant speed control mode

Constant speed control mode is automatically canceled in the following situations:

- Actual vehicle speed is more than approximately 16 km/h (10 mph) below the set vehicle speed.
- Actual vehicle speed falls below approximately 30 km/h (20 mph).
- VSC is activated.
- TRC/A-TRC is activated for a period of time.
- When the VSC or TRC/A-TRC system is turned off.
- Pre-collision braking is activated.
- When the shift lever is in N or the clutch pedal is depressed for a certain amount of time or more. (Vehicles with manual transmission)
- 4WD models: Switching the transfer mode is not completed within 5 seconds while the cruise control system is on.

If constant speed control mode is automatically canceled for any reasons other than the above, there may be a malfunction in the system. Contact your Toyota dealer.

■ The Dynamic Radar Cruise Control with Road Sign Assist may not operate properly when

As the Dynamic Radar Cruise Control with Road Sign Assist may not operate properly in conditions in which RSA may not operate or detect correctly (→P. 244), when using this function, make sure to check the speed limit sign displayed.

In the following situations, the set speed may not be changed to the recognized speed limit by pushing the lever up or down.

- If speed limit information is not available
- When the recognized speed limit is the same as the set speed
- When the recognized speed limit is outside of the speed range that the dynamic radar cruise control system can operate

■ Brake operation

A brake operation sound may be heard and the brake pedal response may change, but these are not malfunctions.

■ Warning messages and buzzers for dynamic radar cruise control

Warning messages and buzzers are used to indicate a system malfunction or to inform the driver of the need for caution while driving. If a warning message is shown on the multi-information display, read the message and follow the instructions. (→P. 218, 426)

■ When the sensor may not be correctly detecting the vehicle ahead

In the case of the following and depending on the conditions, operate the brake pedal when deceleration of the system is insufficient or operate the accelerator pedal when acceleration is required.

As the sensor may not be able to correctly detect these types of vehicles, the approach warning (→P. 255) may not be activated.

- Vehicles that cut in suddenly
- Vehicles traveling at low speeds
- Vehicles that are not moving in the same lane
- Vehicles with small rear ends (trailers with no load on board, etc.)

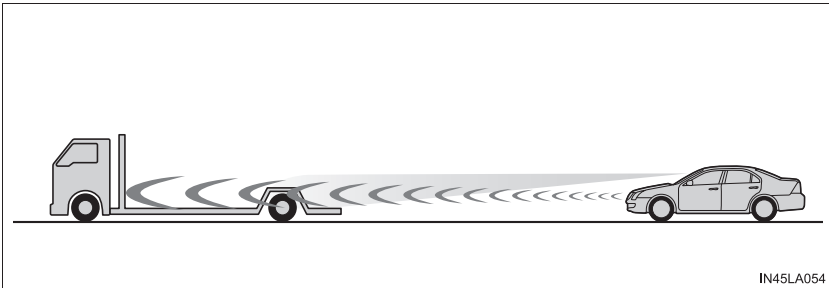

- Motorcycles traveling in the same lane
- When water or snow thrown up by the surrounding vehicles hinders the detecting of the sensor
- When your vehicle is pointing upwards (caused by a heavy load in the luggage compartment, etc.)

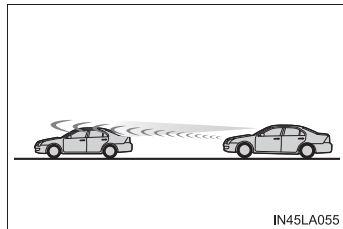

- Preceding vehicle has an extremely high ground clearance

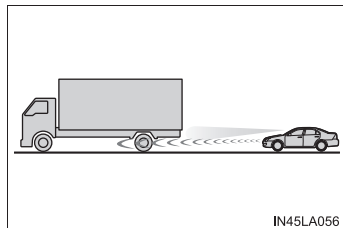

■ Conditions under which the vehicle-to-vehicle distance control mode may not function correctly

In the case of the following conditions, operate the brake pedal (or accelerator pedal, depending on the situation) as necessary.

As the sensor may not be able to correctly detect vehicles ahead, the system may not operate properly.

- When the road curves or when the lanes are narrow

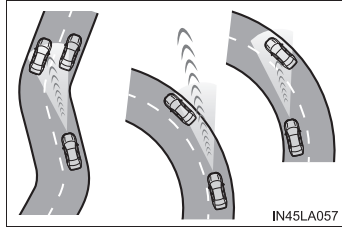

- When steering wheel operation or your position in the lane is unstable

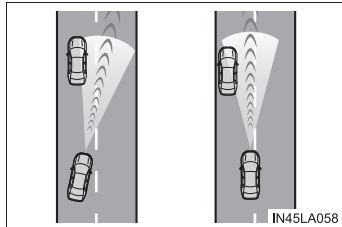

- When the vehicle ahead of you decelerates suddenly
- When driving on a road surrounded by a structure, such as in a tunnel or on a bridge
- While the vehicle speed is decreasing to the set speed after the vehicle accelerates by depressing the accelerator pedal

Toyota parking assist-sensor*

The distance from your vehicle to objects, such as a wall, when parallel parking or maneuvering into a garage is measured by the sensors and communicated via the multi-information display and a buzzer. Always check the surrounding area when using this system.

Types of sensors

- ① Front corner sensors
- ② Rear corner sensors
- ③ Rear center sensors

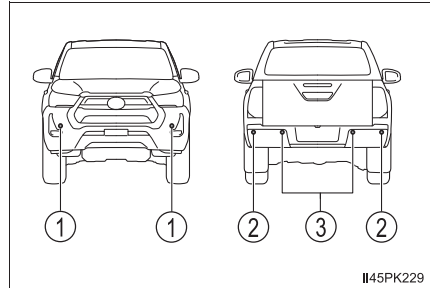

*: If equipped

Turning Toyota parking assist-sensor on/off

Turns Toyota parking assist-sensor on/off

When on, the indicator light comes on to inform the driver that the system is operational.

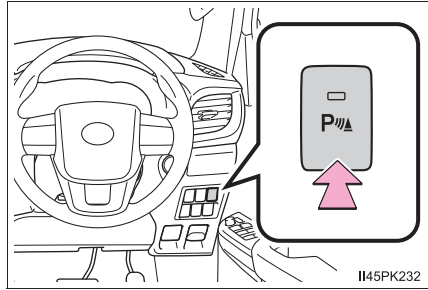

Display

When the sensors detect an object, the following displays inform the driver of the position and distance to the object.

■ Multi-information display*

- ① Front corner sensor operation
- ② Rear corner sensor operation
- ③ Rear center sensor operation



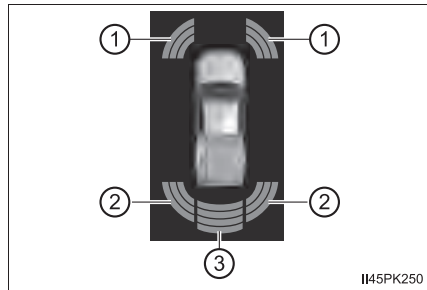

*: The vehicle shown in the illustrations may differ depending on the grade.



Sensor detection display, object distance

■ Distance display

When an object is detected by a sensor, the approximate distance to the object will be displayed on the multi-information display.

Multi-information display*	Approximate distance to object	
	Front corner sensor	Rear center and Rear corner sensor
 (continuous)	—	Rear center sensor only: 150 cm (4.9 ft.) to 80 cm (2.6 ft.)
 (continuous)	60 cm (2.0 ft.) to 45 cm (1.5 ft.)	Rear center sensor: 80 cm (2.6 ft.) to 70 cm (2.3 ft.) Rear corner sensor: 60 cm (2.0 ft.) to 50 cm (1.6 ft.)
 (continuous)	45 cm (1.5 ft.) to 35 cm (1.1 ft.)	Rear center sensor: 70 cm (2.3 ft.) to 60 cm (2.0 ft.) Rear corner sensor: 50 cm (1.6 ft.) to 40 cm (1.3 ft.)
 (blinking)	Less than 35 cm (1.1 ft.)	Rear center sensor: Less than 60 cm (2.0 ft.) Rear corner sensor: Less than 40 cm (1.3 ft.)

*: The images may differ from those shown in the illustrations. (→P. 263)

Buzzer operation and distance to an object

A buzzer sounds when the sensors are operating.

- The buzzer sounds faster as the vehicle approaches an object.
When the vehicle comes within the following distance of the object, the buzzer beeps continuously.
 - Front corner sensor: Approximately 35 cm (1.1 ft.)
 - Rear corner sensor: Approximately 40 cm (1.3 ft.)
 - Rear center sensor: Approximately 60 cm (2.0 ft.)
- When 2 or more objects are detected simultaneously, the buzzer system responds to the nearest object.

Detection range of the sensors

- ① Approximately 60 cm (24 in.)
- ② Approximately 150 cm (59 in.)

The diagram shows the detection range of the sensors. Note that the sensors may not be able to detect objects that are extremely close to the vehicle.

The range of the sensors may change depending on the shape of the object etc.

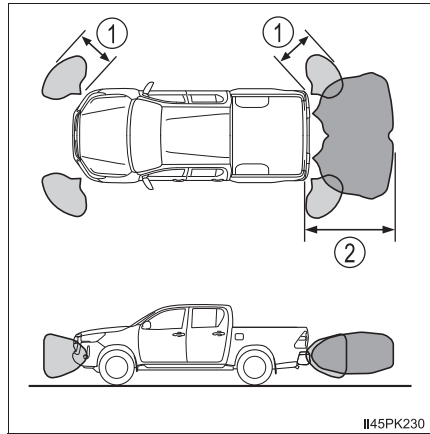

■ Toyota parking assist-sensor can be operated when

- The engine switch is in the “ON” position (vehicles without smart entry & start system) or IGNITION ON mode (vehicles with smart entry & start system).
- Front corner sensor:
 - The shift lever is in other than P.
 - The vehicle speed is approximately 10 km/h (6 mph) or less.
- Rear corner and rear center sensors:
The shift lever is in R.

■ Sensor detection information

- The sensor’s detection areas are limited to the areas around the vehicle’s bumper.
- Depending on the shape of the object and other factors, the detection distance may shorten, or detection may be impossible.
- Detection may be impossible if the objects draw too close to the sensor.
- There will be a short delay between object detection and display. Even at low speeds, there is a possibility that the object will come within the sensor’s detection areas before the display is shown and the warning beep sounds.
- Thin posts or objects lower than the sensor may not be detected when approached, even if they have been detected once.
- It might be difficult to hear the buzzer due to the volume of the audio system or air flow noise of the air conditioning system.

■ Conditions under which the function may not function correctly

Certain vehicle conditions and the surrounding environment may affect the ability of the sensor to correctly detect objects. Particular instances where this may occur are listed below.

- There is dirt, snow or ice on the sensor. (Wiping the sensors will resolve this problem.)
- The sensor is frozen. (Thawing the area will resolve this problem.)
In especially cold weather, if a sensor is frozen, the screen may show an abnormal display, or objects may not be detected.
- The sensor is covered in any way.
- When a sensor or the area around a sensor is extremely hot or cold
- On an extremely bumpy road, on an incline, on gravel, or on grass
- The vicinity of the vehicle is noisy due to vehicle horns, motorcycle engines, air brakes of large vehicles, or other loud noises producing ultrasonic waves.

- There is another vehicle equipped with parking assist sensors in the vicinity.
- The sensor is coated with a sheet of spray or heavy rain.
- If a sensor is hit by a large amount of water, such as when driving on a flooded road.
- If the vehicle is significantly tilted.
- The vehicle is approaching a tall or curved curb.
- If objects draw too close to the sensor.

The shape of the object may prevent the sensor from detecting it. Pay particular attention to the following objects:

- Wires, fences, ropes, etc.
- Cotton, snow and other materials that absorb sound waves
- Sharply-angled objects
- Low objects
- Tall objects with upper sections projecting outwards in the direction of your vehicle
- Moving objects such as people or animals

People may not be detected if they are wearing certain types of clothing.

■ **If “Clean Parking Assist Sensor” is displayed on the multi-information display**

A sensor may be dirty or covered with snow or ice. In such cases, if it is removed from the sensor, the system should return to normal.

Also, due to the sensor being frozen at low temperatures, a malfunction display may appear or an object may not be detected. If the sensor thaws out, the system should return to normal.

■ **If “Parking Assist Malfunction Visit Your Dealer” is displayed on the multi-information display**

Depending on the malfunction of the sensor, the device may not be working normally. Have the vehicle inspected by your Toyota dealer.

■ **If “Parking Assist Malfunction” is displayed on the multi-information display**

Water may be continuously flowing over the sensor surface, such as in a heavy rain. When the system determines that it is normal, the system will return to normal.

■ **Customization**

Setting of buzzer volume can be changed.
(Customizable features: →P. 484)

 **WARNING****■ When using Toyota parking assist-sensor**

Observe the following precautions.

Failure to do so may result in the vehicle being unable to be driven safely and possibly cause an accident.

- Do not use the sensor at speeds in excess of 10 km/h (6 mph).
- The sensors' detection areas and reaction times are limited. When moving forward or reversing, check the areas surrounding the vehicle (especially the sides of the vehicle) for safety, and drive slowly, using the brake to control the vehicle's speed.
- Do not install accessories or a license plate within the sensors' detection areas.
- The area directly under the bumpers is not detected.
Thin posts or objects lower than the sensor may not be detected when approached, even if they have been detected once.

■ When to disable the function

In the following situations, disable the function as it may operate even though there is no possibility of a collision.

- The vehicle is equipped with a fender pole, wireless antenna or fog lights.
- The front or rear bumper or a sensor receives a strong impact.
- A non-genuine Toyota suspension (lowered suspension, etc.) is installed.
- Towing eyelets are installed.
- A backlit license plate is installed.
- If a sensor has been painted.

**NOTICE****■ When using the Toyota parking assist-sensor**

In the following situations, the system may not function correctly due to a sensor malfunction etc. Have the vehicle checked by your Toyota dealer.

- Toyota parking assist-sensor operation display flashes, and a beep sounds when no objects are detected.
- If the area around a sensor collides with something, or is subjected to strong impact.
- If the bumper collides with something.
- If the display shows up and remains on without a beep.

■ Notes when washing the vehicle

Do not apply intensive bursts of water or steam to the sensor area. Doing so may result in the sensor malfunctioning.

- When using a high pressure washer to wash the vehicle, do not spray the sensors directly, as doing so may cause a sensor to malfunction.
- When using steam to clean the vehicle, do not direct steam too close to the sensors as doing so may cause a sensor to malfunction.

Four-wheel drive system*

Use the front-wheel drive control switch to select the following transfer modes.

- ① H2 (high speed position, two-wheel drive)

Use this for normal driving on dry hard-surfaced roads. This position gives greater economy, quietest ride and least wear.

- ② H4 (high speed position, four-wheel drive)

Use this for driving only on tracks that permit the tires slide, like off-road, icy or snow-covered roads. This position provides greater traction than two-wheel drive.

The four-wheel drive indicator light comes on

- ③ L4 (low speed position, four-wheel drive)

Use this for maximum power and traction. Use L4 for climbing or descending steep hills, off-road driving, and hard pulling in sand, mud or deep snow.

The four-wheel drive and low speed four-wheel drive indicator lights come on

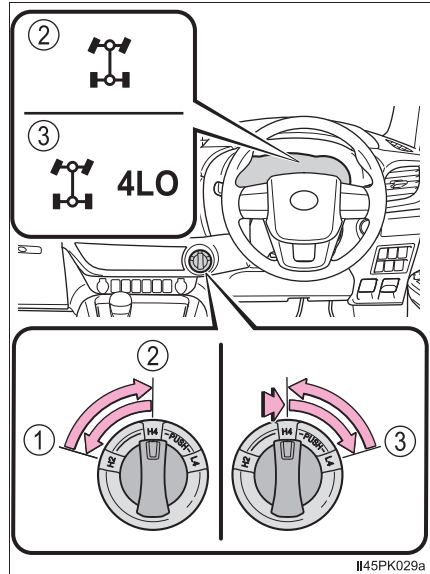

II45PK029a

A.D.D. (automatic disconnecting differential)

The A.D.D. can be engaged or disengaged by the shifting operations described in the following shifting procedures.

*: If equipped

Shifting between H2 and H4

■ Shifting from H2 to H4

- 1 Reduce the vehicle speed to less than 100 km/h (62 mph).

The transfer mode cannot be switched if the vehicle speed is more than 100 km/h (62 mph).

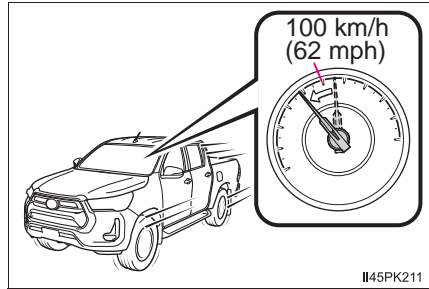

- 2 Turn the front-wheel drive control switch to H4.

The four-wheel drive indicator light flashes while switching.

If turning the front-wheel drive control switch when the vehicle speed is more than 100 km/h (62 mph), the four-wheel drive indicator light flashes and a buzzer sounds.

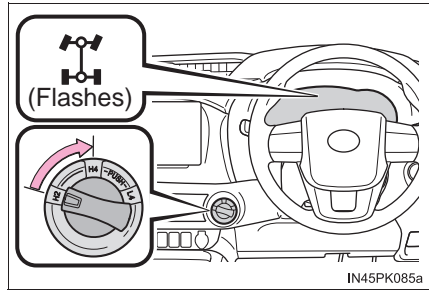

Reduce the vehicle speed to less than 100 km/h (62 mph), or return the front-wheel drive control switch to H2 and try step 1 again.

- 3 Check that the four-wheel drive indicator light comes on.

The four-wheel drive indicator light comes on when switching the transfer mode is completed.

If the four-wheel drive indicator light does not stop flashing after turning the front-wheel drive control switch from H2 to H4, perform any of the followings while driving straight.

- Accelerating
- Decelerating
- Driving in reverse

The four-wheel drive indicator light may not stop flashing if the front-wheel drive control switch is turned from H2 to H4 while the vehicle is stopped. In this case, perform any of the followings.

- Driving forward
- Driving in reverse

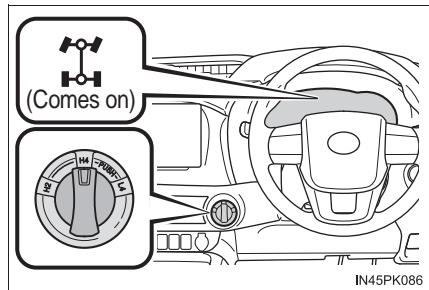

■ Shifting from H4 to H2

- 1 Turn the front-wheel drive control switch to H2.

The four-wheel drive indicator light flashes while switching.

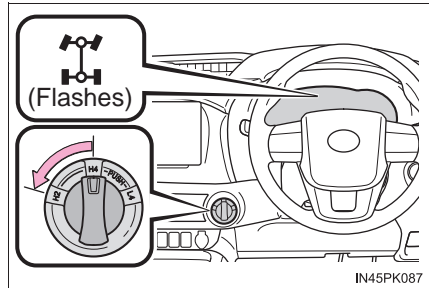

- 2 Check that the four-wheel drive indicator light goes off.

The four-wheel drive indicator light goes off when switching the transfer mode is completed.

If the four-wheel drive indicator light does not stop flashing after turning the front-wheel drive control switch from H4 to H2, perform the followings while driving straight.

- Accelerating
- Decelerating
- Driving in reverse

If the four-wheel drive indicator light is still flashing, perform the operations above while turning the steering wheel left and right.

Impact may be felt through the vehicle body and steering. However, this does not indicate a malfunction.

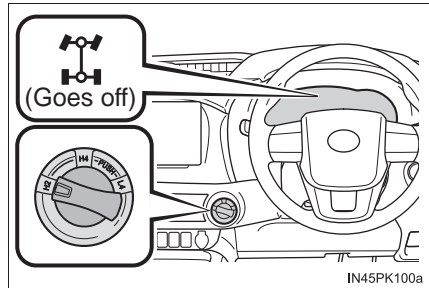

Shifting between H4 and L4 (automatic transmission)

■ Shifting from H4 to L4

- 1 Stop the vehicle.

The transfer mode cannot be switched if the vehicle is moving.

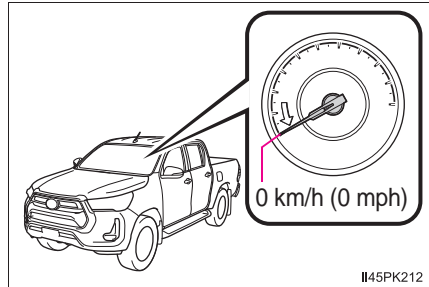

- 2 Shift the shift lever to N.

Keep the shift lever in N until switching the transfer mode is completed (indicator on).

The transfer mode cannot be switched if the shift lever is in other than N.

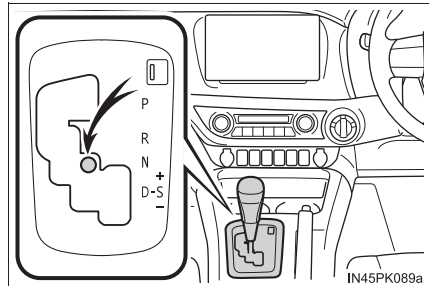

- 3 Push and turn the front-wheel drive control switch to L4.

The low speed four-wheel drive indicator light flashes while switching.

If turning the front-wheel drive control switch without following steps 1 and 2, the low speed four-wheel drive indicator light flashes and a buzzer sounds. Return the front-wheel drive control switch to H4 and try steps 1 and 2 again.

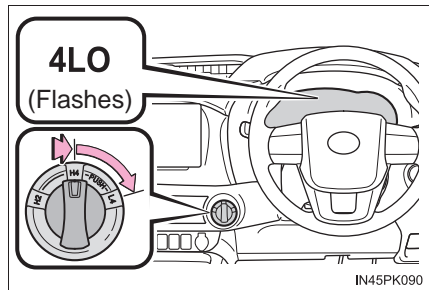

If the shift lever is shifted to other than N while the low speed four-wheel drive indicator light is flashing, gear noise may be caused. Immediately shift the shift lever to N and wait until switching the transfer mode is completed.

- 4 Check that the low speed four-wheel drive indicator light comes on.

The low speed four-wheel drive indicator light comes on when switching the transfer mode is completed.

Shift the shift lever from N to D or R to drive the vehicle.

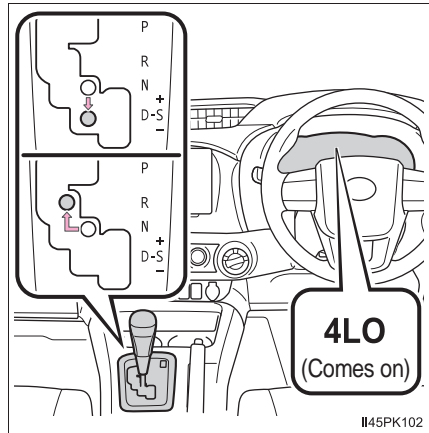

■ Shifting from L4 to H4

- 1 Stop the vehicle.

The transfer mode cannot be switched if the vehicle is moving.

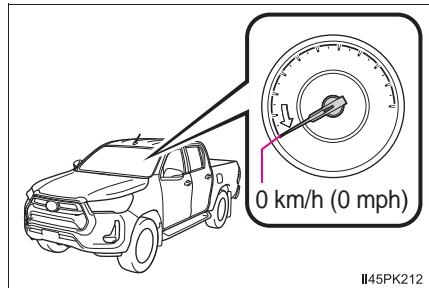

- 2 Shift the shift lever to N.

Keep the shift lever in N until switching the transfer mode is completed (indicator off).

The transfer mode cannot be switched if the shift lever is in other than N.

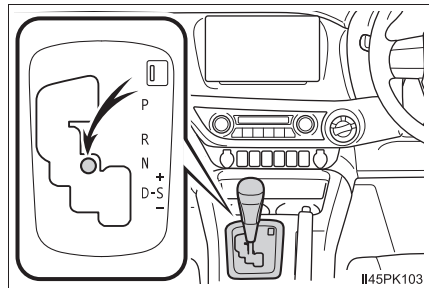

- 3 Turn the front-wheel drive control switch to H4.

The low speed four-wheel drive indicator light flashes while switching.

If turning the front-wheel drive control switch without following steps 1 and 2, the low speed four-wheel drive indicator light flashes and a buzzer sounds. Return the front-wheel drive control switch to L4 and try steps 1 and 2 again.

If the shift lever is shifted to other than N while the low speed four-wheel drive indicator light is flashing, gear noise may be caused. Immediately shift the shift lever to N and wait until switching the transfer mode is completed.

- 4 Check that the low speed four-wheel drive indicator light goes off.

The low speed four-wheel drive indicator light goes off when switching the transfer mode is completed.

Shift the shift lever from N to D or R to drive the vehicle.

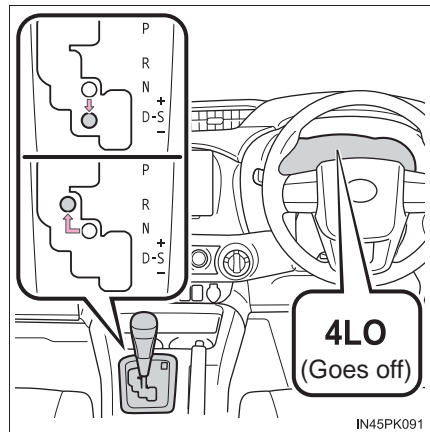
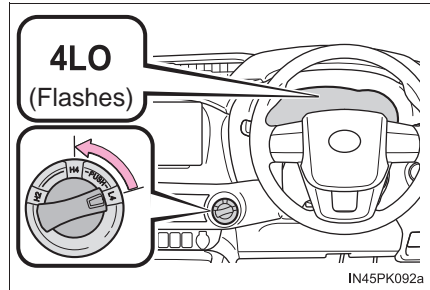

 NOTICE

■ **Shifting between H4 and L4**

Do not shift the shift lever to other than N or depress the accelerator pedal while the low speed four-wheel drive indicator light is flashing. Failure to do so may cause gear noise and result in a malfunction.

Shifting between H4 and L4 (manual transmission)

■ Shifting from H4 to L4

- 1 Stop the vehicle.

The transfer mode cannot be switched if the vehicle is moving.

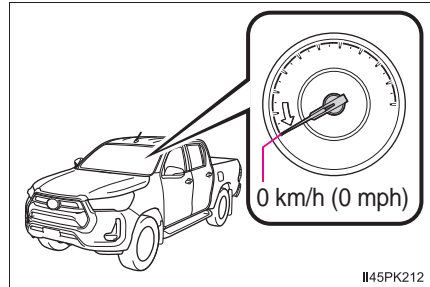

- 2 Firmly depress the clutch pedal.

Keep depressing the clutch pedal until switching the transfer mode is completed (indicator on).

The transfer mode cannot be switched if the clutch pedal is not fully depressed.

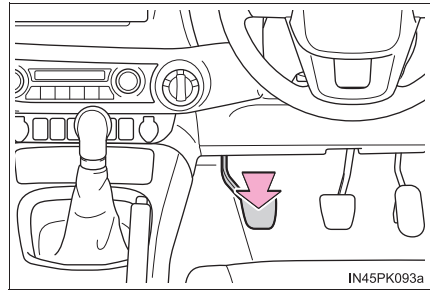

- 3 Push and turn the front-wheel drive control switch to L4.

The low speed four-wheel drive indicator light flashes while switching.

If turning the front-wheel drive control switch without following steps 1 and 2, the low speed four-wheel drive indicator light flashes and a buzzer sounds. Return the front-wheel drive control switch to H4 and try steps 1 and 2 again.

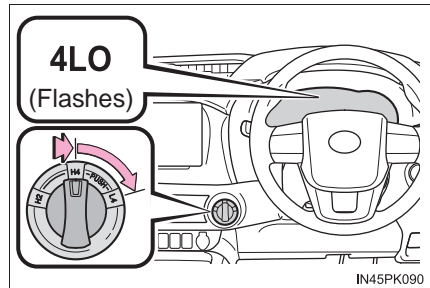

If the clutch pedal is released while the low speed four-wheel drive indicator light is flashing, gear noise may be caused. Immediately depress the clutch pedal firmly and wait until switching the transfer mode is completed.

- 4 Check that the low speed four-wheel drive indicator light comes on.

The low speed four-wheel drive indicator light comes on when switching the transfer mode is completed.

Release the clutch pedal to drive the vehicle.

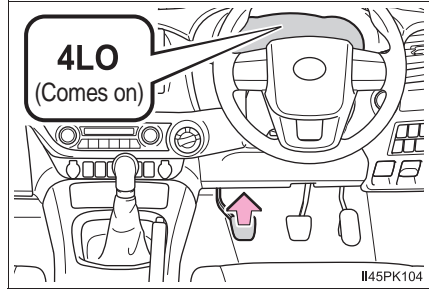

■ Shifting from L4 to H4

- 1 Stop the vehicle.

The transfer mode cannot be switched if the vehicle is moving.

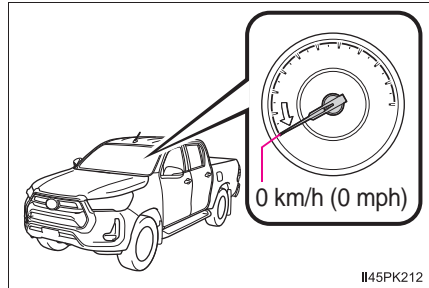

- 2 Firmly depress the clutch pedal.

Keep depressing the clutch pedal until switching the transfer mode is completed (indicator off).

The transfer mode cannot be switched if the clutch pedal is not fully depressed.

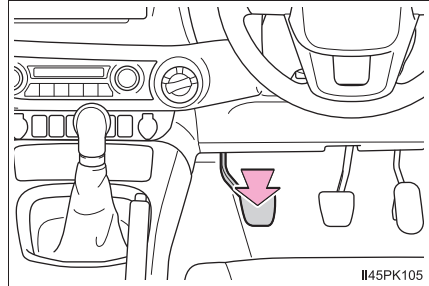

- 3 Turn the front-wheel drive control switch to H4.

The low speed four-wheel drive indicator light flashes while switching.

If turning the front-wheel drive control switch without following steps 1 and 2, the low speed four-wheel drive indicator light flashes and a buzzer sounds. Return the front-wheel drive control switch to L4 and try steps 1 and 2 again.

If the clutch pedal is released while the low speed four-wheel drive indicator light is flashing, gear noise may be caused. Immediately depress the clutch pedal firmly and wait until switching the transfer mode is completed.

- 4 Check that the low speed four-wheel drive indicator light goes off.

The low speed four-wheel drive indicator light goes off when switching the transfer mode is completed.

Release the clutch pedal to drive the vehicle.

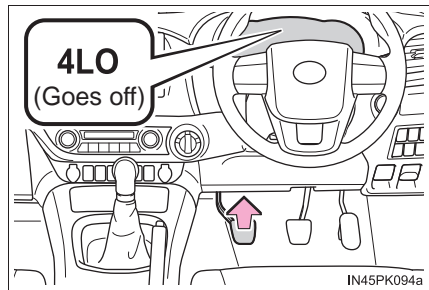
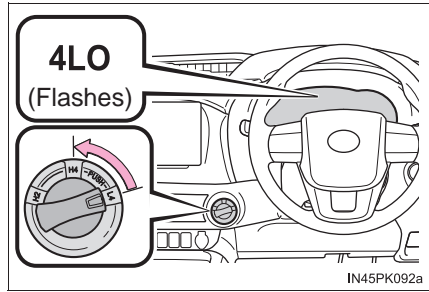

 NOTICE

■ **Shifting between H4 and L4**

Do not release the clutch pedal or depress the accelerator pedal while the low speed four-wheel drive indicator light is flashing. Failure to do so may cause gear noise and result in a malfunction.

■ Four-wheel drive usage frequency

You should drive in four-wheel drive for at least 16 km (10 miles) each month. This will assure that the front drive components are lubricated.

■ Shifting between H2 and H4

If you have trouble shifting in cold weather, reduce your speed or stop the vehicle and reshift.

■ Shifting to L4

VSC is automatically turned off.

■ When driving on dry paved surface roads and expressway

Use H2 position. If the vehicle is driven in H4 or L4 position for a long time, a warning buzzer sounds and a warning message is shown on the multi-information display. If the warning message is shown on the multi-information display, follow the message.

**WARNING****■ While driving**

- Never turn the front-wheel drive control switch from H2 to H4 if the wheels are slipping. Stop the slipping or spinning before shifting.
- For normal driving on dry and hard surface roads, use H2 position. Driving on dry and hard surface roads in H4 or L4 position may cause drive component oil leakage, seizure, or other problems resulting in an accident. Further, it may cause tire wear and increased fuel consumption.
- Avoid turning suddenly in H4 or L4 position. If you do turn suddenly, the difference in turning speeds between the front and rear wheels may have a similar effect to braking, thus making driving difficult.

Rear differential lock system*

The rear differential lock system is provided for use only when wheel spinning occurs in a ditch or on a slippery or ragged surface.

This differential lock system is effective in case one of the rear wheels is spinning.

Press the rear differential lock switch to lock the rear differential.

The rear differential lock indicator comes on.

To unlock the rear differential, push the switch again.

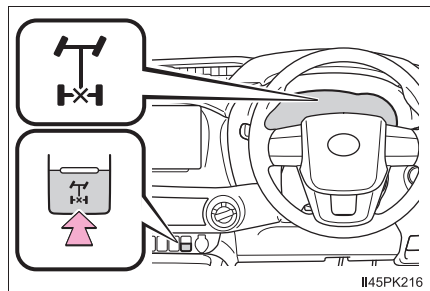

*: If equipped

Using the rear differential lock system

- 1 4WD models only: Before using the rear differential lock system, turn the front-wheel drive control switch to L4 and try to move the vehicle. (→P. 273, 276)

If this is not sufficient, use the rear differential lock system as well.

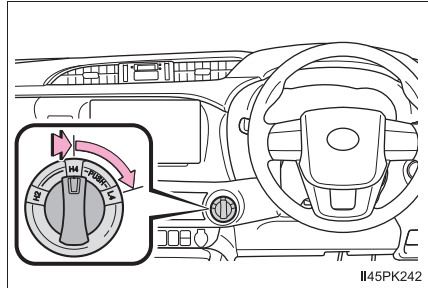

- 2 Reduce the vehicle speed to less than 8 km/h (5 mph).

Make sure that the wheels are not spinning.

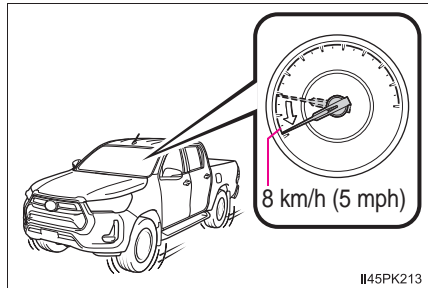

- 3 Press the rear differential lock switch.

The rear differential lock indicator flashes while the rear differential is being locked.

If pressing the rear differential lock switch without following steps 1 and 2, the rear differential lock indicator flashes three times and a buzzer sounds three times, and the rear differential cannot be locked. Try steps 1 and 2 again.

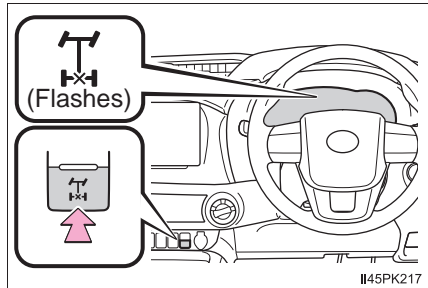

- 4 Gently depress the accelerator pedal.

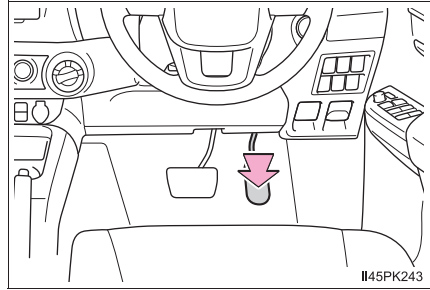

- 5 Check that the rear differential lock indicator comes on.

The rear differential lock indicator comes on when locking the rear differential is completed.

If the rear differential lock indicator does not stop flashing after pressing the rear differential lock switch, perform any of the followings while turning the steering wheel left and right.

- Accelerating
- Decelerating

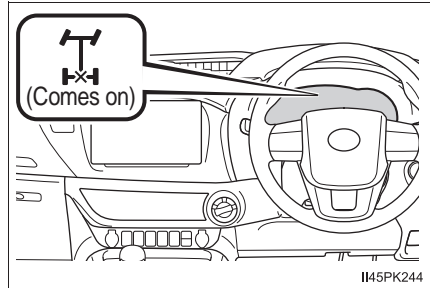

Unlock the rear differential as soon as the vehicle moves. To unlock the rear differential, push the switch again.

■ Locking the rear differential

The following systems do not operate when the rear differential is locked. It is normal operation for the ABS warning light and VSC OFF indicator to be on or for “TRC turned off” to be displayed on the multi-information display at this time.

- ABS
- Brake assist
- VSC
- TRC/A-TRC
- Trailer Sway Control
- Hill-start assist control
- Downhill assist control (if equipped)

■ Unlocking the rear differential

If the rear differential lock indicator still flashes even after unlocking the rear differential, check the safety of the surrounding area and slightly turn the steering wheel in either direction while the vehicle is in motion.

■ Automatic system cancelation of the rear differential lock system

The rear differential lock is also unlocked in any of the following situations:

- The front-wheel drive control switch is turned to H2 or H4 (4WD models)
- The engine switch is turned to the “ACC” or “LOCK” position (vehicles without smart entry & start system) or ACCESSORY or off (vehicles with smart entry & start system)

■ After unlocking the rear differential

Check that the indicator goes off.



WARNING

■ To avoid an accident

Failure to observe the following precautions may result in an accident.

- Do not use the rear differential lock system except when wheel spinning occurs in a ditch or on a slippery or rugged surface. Large steering effort and careful cornering control will be required.
- Do not lock the rear differential until the wheels have stopped spinning. Otherwise, the vehicle may move in an unexpected direction when the differential lock is engaged, resulting in an accident. This may also lead to possible damage to rear differential lock component parts.
- Do not drive over 8 km/h (5 mph) when the differential is locked.
- Do not keep driving with the rear differential lock switch on.

Driving assist systems

To keep driving safety and performance, the following systems operate automatically in response to various driving situations. Be aware, however, that these systems are supplementary and should not be relied upon too heavily when operating the vehicle.

◆ ABS (Anti-lock Brake System)

Helps to prevent wheel lock when the brakes are applied suddenly, or if the brakes are applied while driving on a slippery road surface

◆ Brake assist

Generates an increased level of braking force after the brake pedal is depressed when the system detects a panic stop situation

◆ VSC (Vehicle Stability Control)

Helps the driver to control skidding when swerving suddenly or turning on slippery road surfaces

◆ TRC (Traction Control) for 2WD models, Pre Runner and H2 position on 4WD models

Helps to maintain drive power and prevent the drive wheels from spinning when starting the vehicle or accelerating on slippery roads

◆ A-TRC (Active Traction Control) for H4 and L4 position on 4WD models (if equipped)

Helps to maintain drive power and prevent the four wheels from spinning when starting the vehicle or accelerating on slippery roads

◆ Hill-start assist control

Helps to reduce the backward movement of the vehicle when starting on an uphill

◆ Emergency brake signal

When the brakes are applied suddenly, the emergency flashers automatically flash to alert the vehicle behind.

◆ Trailer Sway Control

Helps the driver to control trailer sway by selectively applying brake pressure for individual wheels and reducing driving torque when trailer sway is detected.

Trailer Sway Control is part of the VSC system and will not operate if VSC is turned off or experiences a malfunction.

When the TRC/A-TRC/VSC/Trailer Sway Control systems are operating

The slip indicator will flash while the TRC/A-TRC/VSC/Trailer Sway Control systems are operating.

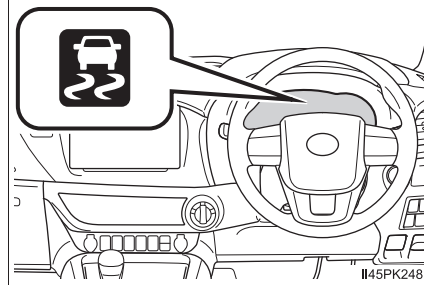

Disabling the TRC/A-TRC systems

If the vehicle gets stuck in mud, dirt or snow, the TRC/A-TRC systems may reduce power from the engine to the wheels. Pressing  to turn the system off may make it easier for you to rock the vehicle in order to free it.

▶ Vehicles without AUTO LSD system

To turn the TRC/A-TRC systems off, quickly press and release .

“TRC turned off” will be shown on the multi-information display.

Press  again to turn the system back on.

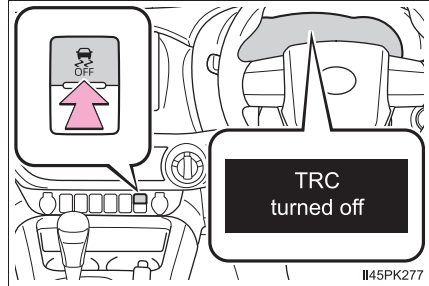

▶ Vehicles with AUTO LSD system

To turn the TRC/A-TRC systems off, quickly press and release . (The AUTO LSD system turns on.*1)

The “AUTO LSD” and VSC OFF indicators will come on.*2

Press  again to turn the system back on.

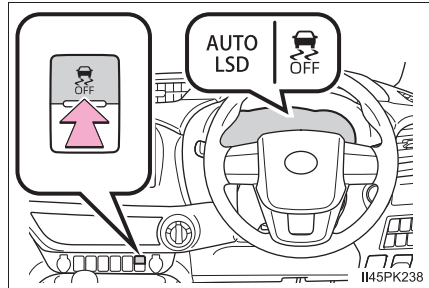

*1: Pre Runner and in 2WD mode on 4WD models only

*2: Pre-collision brake assist and pre-collision braking will also be disabled until the vehicle reaches a certain speed. The PCS warning light will come on and the message will be shown on the multi-information display. (→P. 230)

■ Turning off TRC, A-TRC, VSC and Trailer Sway Control systems

To turn the TRC, A-TRC, VSC and Trailer Sway Control systems off, press and hold  for more than 3 seconds while the vehicle is stopped.

The VSC OFF indicator light will come on and the “TRC turned off” will be shown on the multi-information display.*

Press  again to turn the system back on.

*: Pre-collision brake assist and pre-collision braking will also be disabled. The PCS warning light will come on and the message will be shown on the multi-information display. (→P. 230)

■ When the message is displayed on the multi-information display showing that TRC/A-TRC has been disabled even if has not been pressed

TRC, A-TRC and downhill assist control is temporary deactivated. If the indicator light continues to remain on or the information continues to show, contact your Toyota dealer.

■ Sounds and vibrations caused by the ABS, brake assist, VSC, Trailer Sway Control, TRC, A-TRC and the hill-start assist control systems

- A sound may be heard from the engine compartment when the brake pedal is depressed repeatedly, when the engine is started or just after the vehicle begins to move. This sound does not indicate that a malfunction has occurred in any of these systems.
- Any of the following conditions may occur when the above systems are operating. None of these indicates that a malfunction has occurred.
 - Vibrations may be felt through the vehicle body and steering.
 - A motor sound may be heard also after the vehicle comes to a stop.
 - The brake pedal may pulsate slightly after the ABS is activated.
 - The brake pedal may move down slightly after the ABS is activated.

■ Automatic reactivation of TRC, A-TRC, VSC and Trailer Sway Control systems

After turning the TRC, A-TRC, VSC and Trailer Sway Control systems off, the systems will be automatically re-enabled in the following situations:

- When the engine switch is turned to the “LOCK” position (vehicles without smart entry & start system) or off (vehicles with smart entry & start system).
- If only the TRC/A-TRC system is turned off (→P. 286), the TRC/A-TRC will turn on when vehicle speed increases.

If the TRC, A-TRC, VSC and Trailer Sway Control systems are turned off (→P. 287), automatic re-enabling will not occur when vehicle speed increases.

■ Operating conditions of the hill-start assist control

When the following four conditions are met, the hill-start assist control will operate:

- Vehicles with automatic transmission: The shift lever is in a position other than P or N (when starting off forward/backward on an upward incline)
Vehicles with manual transmission: The shift lever is in a position other than R when starting off forward on an upward incline, or the shift lever is in R when starting off backward on an upward incline.
- The vehicle is stopped
- The accelerator pedal is not depressed
- The parking brake is not engaged

■ Automatic system cancelation of the hill-start assist control

The hill-start assist control will turn off in any of the following situations:

- Vehicles with automatic transmission: The shift lever is shifted to P or N
Vehicles with manual transmission: The shift lever is shifted to R when starting off forward on an upward incline, or the shift lever is shifted to other than R when starting off backward on an upward incline.
- The accelerator pedal is depressed
- The parking brake is engaged
- 2 seconds at maximum elapsed after the brake pedal is released

■ Operating conditions of emergency brake signal

When the following conditions are met, the emergency brake signal will operate:

- The emergency flashers are off.
- Actual vehicle speed is over 55 km/h (35 mph).
- The system judges from the vehicle deceleration that it is a sudden braking operation.

■ Automatic system cancelation of emergency brake signal

The emergency brake signal will be canceled in any of the following situations:

- The emergency flashers are turned on.
- The system judges from the vehicle deceleration that is not a sudden braking operation.

 **WARNING****■ The ABS does not operate effectively when**

- The limits of tire gripping performance have been exceeded (such as excessively worn tires on a snow covered road).
- The vehicle hydroplanes while driving at high speed on wet or slick roads.

■ Stopping distance when the ABS is operating may exceed that of normal conditions

The ABS is not designed to shorten the vehicle's stopping distance. Always maintain a safe distance from the vehicle in front of you, especially in the following situations:

- When driving on dirt, gravel or snow-covered roads
- When driving with tire chains
- When driving over bumps in the road
- When driving over roads with potholes or uneven surfaces

■ TRC/A-TRC/VSC may not operate effectively when

Directional control and power may not be achievable while driving on slippery road surfaces, even if the TRC/A-TRC/VSC system is operating. Drive the vehicle carefully in conditions where stability and power may be lost.

■ Hill-start assist control does not operate effectively when

- Do not overly rely on the hill-start assist control. The hill-start assist control may not operate effectively on steep inclines and roads covered with ice.
- Unlike the parking brake, the hill-start assist control is not intended to hold the vehicle stationary for an extended period of time. Do not attempt to use the hill-start assist control to hold the vehicle on an incline, as doing so may lead to an accident.

■ When the TRC/VSC/Trailer Sway Control is activated

The slip indicator flashes. Always drive carefully.

Reckless driving may cause an accident. Exercise particular care when the indicator flashes.

■ When the TRC/A-TRC/VSC/Trailer Sway Control systems are turned off

Be especially careful and drive at a speed appropriate to the road conditions. As these are the systems to help ensure vehicle stability and driving force, do not turn the TRC/A-TRC/VSC/Trailer Sway Control systems off unless necessary.

 **WARNING****■ Replacing tires**

Make sure that all tires are of the specified size, brand, tread pattern and total load capacity. In addition, make sure that the tires are inflated to the recommended tire inflation pressure level.

The ABS, TRC, A-TRC, VSC, Trailer Sway Control, hill-start assist control and downhill assist control systems will not function correctly if different tires are installed on the vehicle.

Contact your Toyota dealer for further information when replacing tires or wheels.

■ Handling of tires and the suspension

Using tires with any kind of problem or modifying the suspension will affect the driving assist systems, and may cause a system to malfunction.

■ Trailer Sway Control precaution

The Trailer Sway Control system is not able to reduce trailer sway in all situations. Depending on many factors such as the conditions of the vehicle, trailer, road surface, and driving environment, the Trailer Sway Control system may not be effective. Refer to your trailer owner's manual for information on how to tow your trailer properly.

■ If trailer sway occurs

Observe the following precautions.

Failing to do so may cause death or serious injury.

- Firmly grip the steering wheel. Steer straight ahead.

Do not try to control trailer sway by turning the steering wheel.

- Begin releasing the accelerator pedal immediately but very gradually to reduce speed.

Do not increase speed. Do not apply vehicle brakes.

If you make no extreme correction with the steering or brakes, your vehicle and trailer should stabilize. (→P. 167)

Downhill assist control system*

The downhill assist control system helps to prevent excessive speed on steep downhill slopes.

The system will operate when the vehicle is traveling under 30 km/h (18 mph) and transfer mode is in L4 or H4.

System operation

Press the “DAC” switch. The downhill assist control system indicator will come on and the system will operate.

When the system is in operation, the slip indicator will flash, and the stop lights/high mounted stop lights will be lit. A sound may also occur during the operation. This does not indicate a malfunction.

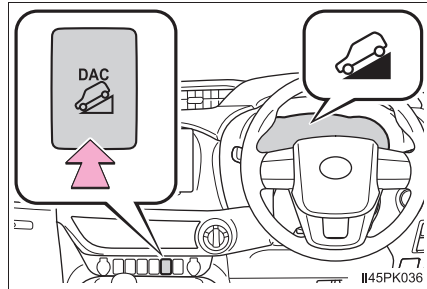

Turning off the system

Press the “DAC” switch while the system is in operation. The downhill assist control system indicator will flash as the system gradually ceases operation, and will turn off when the system is fully off.

Press the “DAC” switch while the downhill assist control system indicator is flashing to start the system again.

■ Operating tips (vehicles with automatic transmission)

The system will operate when the shift lever is in a position other than P, however to make effective use of the system it is recommended to select a lower shift range.

■ The system will not operate when

- The transfer mode is in H2.
- The rear differential is locked.

■ If the downhill assist control system indicator flashes

- In the following situations, the indicator flashes and the system will not operate:
 - The transfer mode is not in L4 or H4.
 - The rear differential is locked.
 - The shift lever is in P. (vehicles with automatic transmission)
 - The accelerator or brake pedal is depressed.
 - The vehicle speed exceeds approximately 30 km/h (18 mph).
 - The brake system overheats.
- In the following situations, the indicator flashes to alert the driver, but the system will operate:
 - The shift lever is in N. (vehicles with automatic transmission)
 - The clutch pedal is depressed. (vehicles with manual transmission)
 - The “DAC” switch is turned off while the system is operating.

The system will gradually cease operation. The indicator will flash during operation, and then go off when the system is fully off.

■ When the downhill assist control system is operated continuously

This may cause the brake actuator to overheat. In this case, the downhill assist control system will stop operating, a buzzer will sound and the downhill assist control system indicator will start flashing, and “TRC turned off” will be shown on the multi-information display. Refrain from using the system until the downhill assist control system indicator stays on and the message goes off. (The vehicle can be driven normally during this time.)

■ Sounds and vibrations caused by the downhill assist control system

- A sound may be heard from the engine compartment when the engine is started or just after the vehicle begins to move. This sound does not indicate that a malfunction has occurred in downhill assist control system.
- Either of the following conditions may occur when the downhill assist control system is operating. None of these are indicators that a malfunction has occurred.
 - Vibrations may be felt through the vehicle body and steering.
 - A motor sound may be heard after the vehicle comes to a stop.

■ System malfunction

In the following cases, have your vehicle checked by your Toyota dealer.

- The downhill assist control system indicator does not come on when the engine switch is turned to the “ON” position (vehicles without smart entry & start system) or IGNITION ON mode (vehicles with smart entry & start system).
- The downhill assist control system indicator does not come on when the “DAC” switch is pressed.
- The slip indicator comes on.

WARNING

■ When using downhill assist control system

- Do not rely overmuch on the downhill assist control system. This function does not extend the vehicle’s performance limitations. Always thoroughly check the road conditions, and drive safely.
- Vehicles with manual transmission: Drive in a low gear. Driving in a high gear when using downhill assist control system may cause the engine to stall, which may lose the brake effectiveness and lock the tires, resulting in an accident.
- Vehicles with manual transmission: On a steep slope, use the engine braking efficiently. If the vehicle is driven in N or with the clutch pedal depressed on a steep slope, the load on the brake increases and controlling the vehicle speed may be impossible, resulting in an accident.

■ The system may not operate on the following surfaces, which may lead to an accident causing death or serious injury



- Slippery surfaces such as wet or muddy roads
- Icy surface
- Unpaved roads

AUTO LSD*

The AUTO LSD system aids traction by using the traction control system to control engine performance and braking when one of the drive wheels begins to spin. The system should be used only when one of the drive wheels spinning occurs in a ditch or rough surface.

System operation

The system can be used on Pre Runner and in 2WD mode on 4WD models.

To turn the AUTO LSD system on, quickly press and release . The “AUTO LSD” indicator light and VSC OFF indicator light will come on. Press  again to turn the system off.

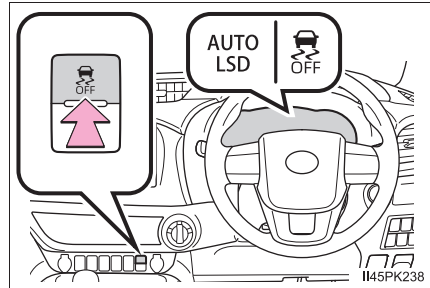

When the AUTO LSD system is operating

If the drive wheels spin, the slip indicator flashes to indicate that the AUTO LSD system has controlled the spinning of the drive wheels.

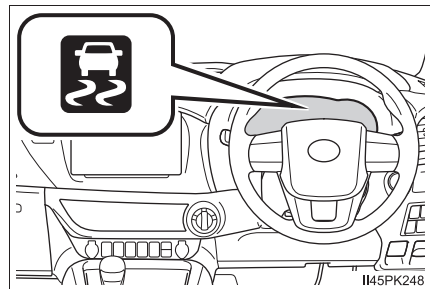

*: If equipped

■ If the engine is turned off and restarted

The AUTO LSD system and the indicators are automatically turned off.

■ Reactivation of the VSC system linked to vehicle speed

When the AUTO LSD system is turned on, the VSC and TRC systems will turn on automatically if vehicle speed increase.

■ If the brake system overheats

The system will cease operation and a buzzer will alert the driver. At this time, the "AUTO LSD" indicator will flash and "TRC turned off" will be shown on the multi-information display. Stop the vehicle in a safe place. (There is no problem with continuing normal driving.) The system will be automatically restored after a short time.

**WARNING****■ To avoid an accident**

Failure to do so, a much greater steering effort and more careful cornering control will be required.

- Do not use the AUTO LSD system in conditions other than when one of the drive wheels spinning occurs in a ditch or rough surface.
- Do not drive with the AUTO LSD system continuously turned on.

**NOTICE****■ Activating while driving**

Do not activate the AUTO LSD system if the wheel is slipping. Stop the slipping or spinning before activating.

DPF (Diesel Particulate Filter) system*

When the deposit collected by the filter reaches a predetermined amount, it is automatically regenerated.

⚠ WARNING

■ During regeneration

Observe the following precautions.

Failure to do so may result in serious injury such as burns caused by the hot exhaust pipe and exhaust gases, or may cause a fire.

- Do not stop the vehicle where flammable materials, such as dry grass, are near the exhaust pipe.

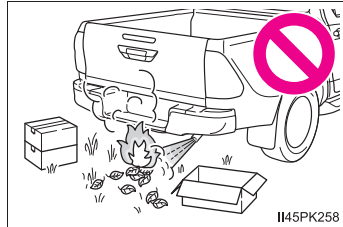

- Make sure that there are no people near the exhaust pipe.

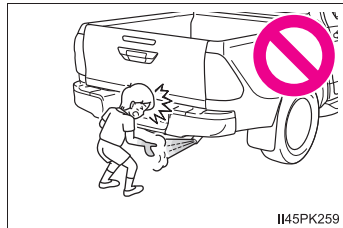

- Do not carry out regeneration when the vehicle is in an enclosed area, such as a garage.
- Do not touch the exhaust pipe and exhaust gases during regeneration.

⚠ NOTICE

■ To prevent the DPF system from failing

- Do not drive for long periods of time while the DPF system warning message “DPF full Visit your dealer” appears on the multi-information display and a buzzer sounds (malfunction indicator lamp comes on)
- Do not use fuel other than the specified type
- Do not use engine oil other than the recommended type
- Do not modify the exhaust pipe

*: If equipped

◆ Regeneration

- During normal driving, the filter is automatically regenerated every several hundred kilometers*. During regeneration, the DPF system warning message “DPF regeneration in progress” is displayed on the multi-information display.
- When the amount of accumulate deposit reaches a certain level, regeneration can also be performed. (→P. 298)

*: Differs in accordance with weather, driving conditions, etc.

◆ System characteristics

The DPF system has the following characteristics:

- Idle speed increases during regeneration
- The smell of the exhaust gas differs from that of a conventional diesel vehicle
- White smoke may be emitted from the exhaust pipe during regeneration. However, this does not indicate a malfunction.

DPF deposition status

The amount of accumulated deposit in the DPF system can be confirmed on the multi-information display.

The DPF deposition status appears when the DPF system switch is pressed or the warning message is displayed. Use the displayed DPF deposition as a reference.

- ① Low
- ② Full

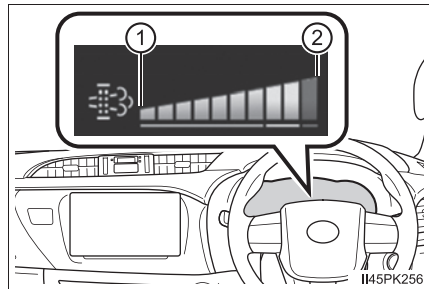

DPF system failure warning

- If the DPF system warning message “DPF full See owner’s manual” appears on the multi-information display, follow the procedure below to regenerate.

- ▶ When regenerating the filter during driving the vehicle

To regenerate the filter, the following driving methods are recommended.*1

- By driving continuously (for example, at around 60 km/h [37 mph] for 20 to 30 minutes).
- By avoiding short trips, or by driving continuously (leaving the engine running for long periods of time).

Check the engine is warmed up before driving the vehicle to regenerate the filter. If the engine is cold, warm up the engine by driving the vehicle downshifting to increase the engine speed.*2

The warning message will disappear on the multi-information display when regeneration is complete. However, depending on the driving condition such as heavy traffic, the amount of accumulated deposit increases and the warning message may not disappear on the multi-information display. If the warning message does not disappear on the multi-information display after driving, press the DPF system switch to manually regenerate the filter.

Regeneration during driving cannot be performed when the vehicle is higher than 4000 m (13124 ft.) above sea level.

*1: When driving, pay sufficient attention to weather, road conditions, terrain and traffic conditions, and drive according to traffic laws.

*2: Depending on the situation, it may be necessary to downshift until the engine speed is increased to 3000 rpm. If the engine coolant temperature or exhaust gas temperature is low, it may take a long time to regenerate, or regeneration may be impossible.

► When regenerating the filter by pressing the DPF system switch

- 1 Stop the vehicle in a safe place.
- 2 Shift the shift lever to P (automatic transmission) or N (manual transmission), and firmly set the parking brake.

Do not stop the engine.

Also, make sure that there are no flammable materials near the exhaust pipe. (→P. 296)

Check the engine is warmed up. If the engine is cold, warm up the engine by depressing the accelerator pedal.*1

- 3 Press the DPF system switch.

The DPF system warning message shown in the illustration appears on the multi-information display, and the idling engine speed will increase.

Regeneration will take around 15 - 40 minutes to complete.*2

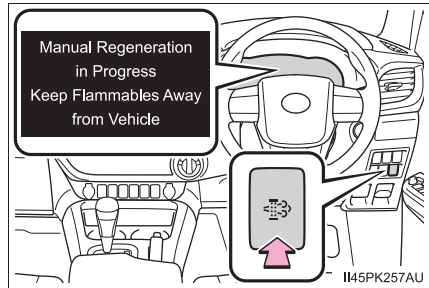

When the DPF system warning message disappears on the multi-information display, the idling engine speed will have finished returning to normal.

The DPF system switch may not operate when the vehicle is higher than 4000 m (13123 ft.) above sea level.

*1: Depending on the situation, it may be necessary to depress the accelerator pedal until the engine speed is increased to 3000 rpm.

If the engine coolant temperature or exhaust gas temperature is low, it may take a long time to regenerate, or regeneration may be impossible.

*2: Time required for regeneration differs in accordance with the outside temperature. Also, if the engine speed is still approximately 2000 rpm 10 minutes after pressing the DPF system switch, the exhaust gas temperature may be low. In this case, depress the accelerator pedal to run the engine at approximately 3000 rpm for a while.

When depressing the accelerator pedal, regeneration will be stopped. In this case, restart regeneration.

- If the “DPF full Manual regeneration required See owner’s manual” appears on the multi-information display, press the DPF system switch to regenerate the filter. (→P. 298)
- If the DPF system warning message “DPF full Visit your dealer” appears on the multi-information display and a buzzer sounds (malfunction indicator lamp comes on), have the vehicle inspected by your Toyota dealer immediately.

■ Regeneration with the DPF system switch

- After pressing the DPF system switch, depressing the accelerator pedal or clutch pedal (manual transmission) will stop regeneration. If regeneration has been stopped, restart regeneration as soon as possible.
- After regeneration is finished, race the engine several time to clean the exhaust system.

■ DPF system warning

Under the following driving conditions, the DPF system warning message may be displayed on the multi-information display earlier than normal.*

- When only driving at low speeds (for example 20 km/h [12 mph] or below).
- If the engine is turned on and off frequently (if the engine is not left running for more than 10 minutes at a time).

*: Differs in accordance with weather, driving conditions, etc.



NOTICE

■ If the malfunction indicator lamp comes on (warning buzzer)

The malfunction indicator lamp comes on if you continue driving while the DPF system warning message appears on the multi-information display. In this event, damage may be caused to the vehicle or an accident may occur. Have the vehicle inspected by your Toyota dealer immediately.

Winter driving tips

Carry out the necessary preparations and inspections before driving the vehicle in winter. Always drive the vehicle in a manner appropriate to the prevailing weather conditions.

Preparation for winter

- Use fluids that are appropriate to the prevailing outside temperatures.
 - Engine oil
 - Engine coolant
 - Washer fluid
- Have a service technician inspect the condition of the battery.
- Have the vehicle fitted with four snow tires or purchase a set of tire chains for the rear tires.

Ensure that all tires are the same size and brand, and that chains match the size of the tires.

Before driving the vehicle

Perform the following according to the driving conditions:

- Do not try to forcibly open a window or move a wiper that is frozen. Pour warm water over the frozen area to melt the ice. Wipe away the water immediately to prevent it from freezing.
- To ensure proper operation of the climate control system fan, remove any snow that has accumulated on the air inlet vents in front of the windshield.
- Check for and remove any excess ice or snow that may have accumulated on the exterior lights, vehicle's roof, chassis, around the tires or on the brakes.
- Remove any snow or mud from the bottom of your shoes before getting in the vehicle.

When driving the vehicle

Accelerate the vehicle slowly, keep a safe distance between you and the vehicle ahead, and drive at a reduced speed suitable to road conditions.

When parking the vehicle (in the winter time or in the cold latitudes)

- Park the vehicle and move the shift lever to P (automatic transmission) or 1 or R (manual transmission) without setting the parking brake. The parking brake may freeze up, preventing it from being released. If the vehicle is parked without setting the parking brake, make sure to block the wheels.

Failure to do so may be dangerous because it may cause the vehicle to move unexpectedly, possibly leading to an accident.

- Vehicles with automatic transmission: If the vehicle is parked without setting the parking brake, confirm that the shift lever cannot be moved out of P*.

*: The shift lever will be locked if it is attempted to be shifted from P to any other position without depressing the brake pedal. If the shift lever can be shifted from P, there may be a problem with the shift lock system. Have the vehicle inspected by your Toyota dealer immediately.

Selecting tire chains

Use the correct tire chain size when mounting the snow chains. Chain size is regulated for each tire size.

Regulations on the use of tire chains

Regulations regarding the use of tire chains vary depending on location and type of road. Always check local regulations before installing chains.

■ Tire chain installation

Observe the following precautions when installing and removing chains:

- Install and remove tire chains in a safe location.
- Install tire chains on the rear tires. Do not install tire chains on the front tires.
- Install tire chains on rear tires as tightly as possible. Retighten chains after driving 0.5 - 1.0 km (1/4 - 1/2 mile).
- Install tire chains following the instructions provided with the tire chains.

 **WARNING****■ Driving with snow tires**

Observe the following precautions to reduce the risk of accidents. Failing to do so may result in a loss of vehicle control and cause death or serious injury.

- Use tires of the specified size.
- Maintain the recommended level of air pressure.
- Do not drive at speeds in excess of the speed limit or the speed limit specified for the snow tires being used.
- Use snow tires on all, not just some wheels.

■ Driving with tire chains

Observe the following precautions to reduce the risk of accidents. Failing to do so may result in the vehicle being unable to be driven safely, and may cause death or serious injury.

- Do not drive in excess of the speed limit specified for the tire chains being used, or 50 km/h (30 mph), whichever is lower.
- Avoid driving on bumpy road surfaces or over potholes.
- Avoid sudden acceleration, abrupt steering, sudden braking and shifting operations that cause sudden engine braking.
- Slow down sufficiently before entering a curve to ensure that vehicle control is maintained.
- Do not use LDA (Lane Departure Alert with Yaw Assist Function) system.

5-1. Using the air conditioning system and defogger

Manual air conditioning system	306
Automatic air conditioning system	311
Seat heaters	319

5-2. Using the interior lights

Interior lights list.....	320
• Personal/interior light main switch.....	321
• Personal/interior lights	321
• Interior light.....	321

5-3. Using the storage features

List of storage features	323
• Glove box	324
• Console box	324
• Cup holders	325
• Bottle holders	326
• Auxiliary boxes	327
Luggage compartment features.....	330

5-4. Using the other interior features

Other interior features.....	331
• Sun visors.....	331
• Vanity mirror	331
• Clock	332
• Power outlets.....	333
• Grocery bag hooks	335
• Coat hooks	335
• Armrest.....	336

Manual air conditioning system*

Air conditioning controls

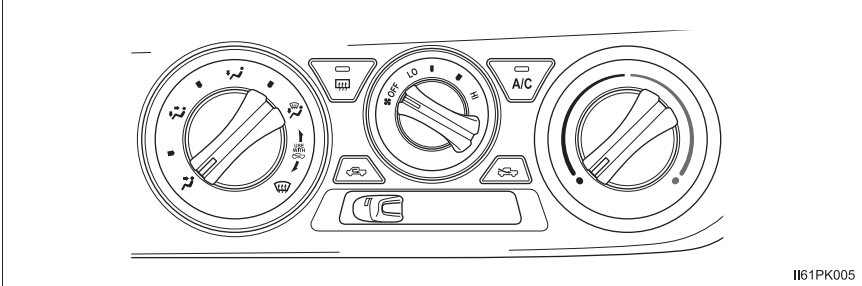



■ Adjusting the fan speed setting

Turn  clockwise (increase) or counterclockwise (decrease).

Turning the dial to “OFF” turns off the fan.

■ Adjusting the temperature setting

Turn  clockwise (warm) or counterclockwise (cool).

If the  is not pressed, the system will blow ambient temperature air or heated air.

■ Changing the air flow mode



Set  to the desired position.

The positions between the air outlet selections can also be selected for more delicate adjustment.

Other functions

■ Switching between outside air and recirculated air modes

Move the outside/recirculated air mode lever.



The mode switches between  (introduces air from outside the vehicle) and  (recycles air inside the vehicle) each time the lever is moved.

■ Defogging the windshield

- 1 Set the air outlet selector dial to  position.

Set the outside/recirculated air mode lever to outside air mode if recirculated air mode is used.

- 2 Perform the following operations accordingly:

- To adjust the fan speed, turn .
- To adjust the temperature setting, turn .
- If the dehumidification function is not operating, press  to operate the dehumidification function.

To defog the windshield and the side windows early, turn the air flow and temperature up.

■ Defogging the rear window

Defogger is used to defog the rear window.

Press .

■ Heater idle up (if equipped)

This feature is used to heat the engine coolant, speed up warming of the cab in cold weather, and keep the cab warm when the vehicle is not moving.

Press the switch to turn the heater idle up on/off.

If you do not turn the switch to off, the engine speed may be increased when the engine is started.

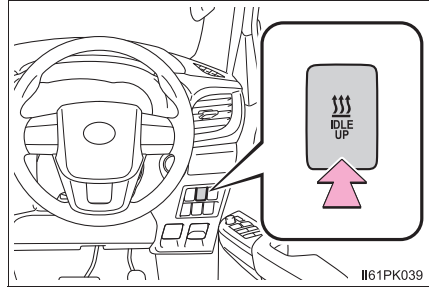

Air outlets

■ Location of air outlets

The air outlets and air volume changes according to the selected air flow mode.

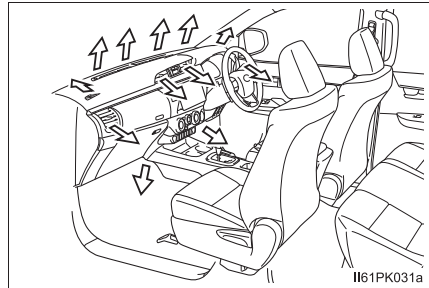

■ Adjusting the air flow direction and opening/closing the air outlets

► Center outlets

- ① Direct air flow to the left or right, up or down.
- ② Close the vents.

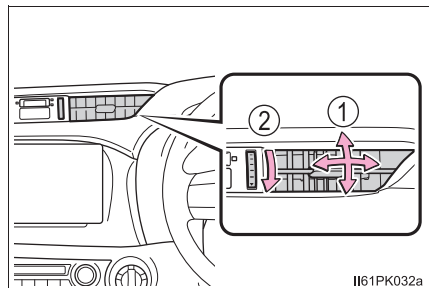

► Side outlets

- ① Direct air flow to the left or right, up or down.
- ② Close the vents.

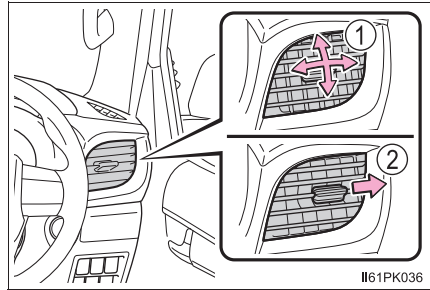

■ **Fogging up of the windows**

- The windows will easily fog up when the humidity in the vehicle is high.

Turning  on will dehumidify the air from the outlets and defog the windshield effectively.

- If you turn  off, the windows may fog up more easily.

- The windows may fog up if the recirculated air mode is used.

■ **When driving on dusty roads**

Close all windows. If dust thrown up by the vehicle is still drawn into the vehicle after closing the windows, it is recommended that the air intake mode be set to outside air mode and the fan speed to any setting except off.

■ **Outside/recirculated air mode**

Setting to the recirculated air mode temporarily is recommended in preventing dirty air from entering the vehicle interior and helping to cool the vehicle when the outside air temperature is high.

■ **When the outside temperature falls to nearly 0°C (32°F)**

The dehumidification function may not operate even when  is pressed.

■ Ventilation and air conditioning odors

- To let fresh air in, set the air conditioning system to the outside air mode.
- During use, various odors from inside and outside the vehicle may enter into and accumulate in the air conditioning system. This may then cause odor to be emitted from the vents.
- To reduce potential odors from occurring:
It is recommended that the air conditioning system be set to outside air mode prior to turning the vehicle off.

■ Air conditioning filter

→P. 371

WARNING

■ To prevent the windshield from fogging up

- Do not set the air outlet selector dial to  during cool air operation in extremely humid weather. The difference between the temperature of the outside air and that of the windshield can cause the outer surface of the windshield to fog up, blocking your vision.
- Do not place anything on the instrument panel which may cover the air outlets. Otherwise, air flow may be obstructed, preventing the windshield defoggers from defogging.

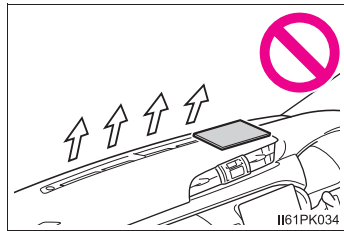

NOTICE

■ To prevent battery discharge

Do not leave the air conditioning system on longer than necessary when the engine is off.

Automatic air conditioning system*

Air outlets and fan speed are automatically adjusted according to the temperature setting.

Air conditioning controls

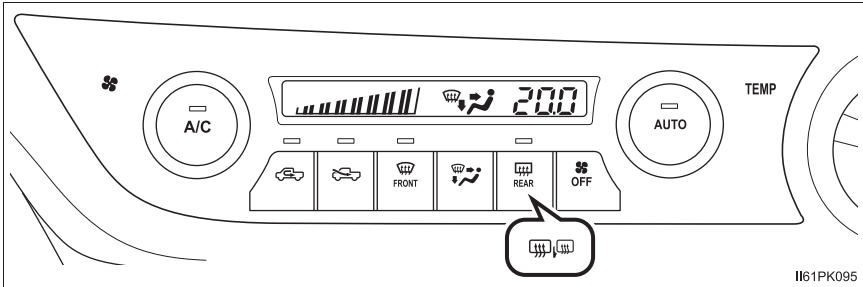



■ Adjusting the fan speed setting

Turn  clockwise (increase) or counterclockwise (decrease).

Press  to turn the fan off.

■ Adjusting the temperature setting

Turn  clockwise (warm) or counterclockwise (cool).

If  is not pressed, the system will blow ambient temperature air or heated air.

■ Changing the air flow mode

Press  to change the air outlets.

The air outlets used are switched each time the button is pressed.

- ① Air flows to the upper body.
- ② Air flows to the upper body and feet.
- ③ Mainly air flows to the feet.
- ④ Air flows to the feet and the windshield defogger operates.

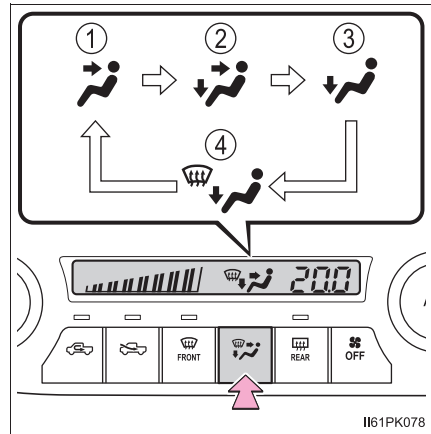



Using automatic mode

- 1 Press .

The dehumidification function begins to operate. Air outlets and fan speed are automatically adjusted according to the temperature setting.

- 2 Turn  clockwise (warm) or counterclockwise (cool) to adjust the temperature.

- 3 Press .

The cooling and dehumidification function switches between on and off each time  is pressed.



To stop the operation, press .

■ Automatic mode indicator

If the fan speed setting or air flow modes are operated, the automatic mode indicator goes off. However, automatic mode for functions other than that operated is maintained.

Other functions

■ Switching between outside air and recirculated air modes

Press  to switch to recirculated air mode and press  to switch to outside air mode.

■ Defogging the windshield

Press .

The dehumidification function operates and fan speed increases.

Press  if the recirculated air mode is used. (It may switch automatically.)

To defog the windshield and the side windows early, turn the air flow and temperature up.

To return to the previous mode, press  again when the windshield is defogged.

■ Defogging the rear window and outside rear view mirrors (if equipped)

Defoggers are used to defog the rear window, and to remove rain-drops, dew and frost from the outside rear view mirrors.

▶ Vehicles without outside rear view mirror defoggers

Press .

The defogger will automatically turn off after approximately 15 to 60 minutes.

▶ Vehicles with outside rear view mirror defoggers

Press .

The defogger will automatically turn off after approximately 15 to 60 minutes.

■ Heater idle up (if equipped)

This feature is used to heat the engine coolant, speed up warming of the cab in cold weather, and keep the cab warm when the vehicle is not moving.

Press the switch to turn the heater idle up on/off.

If you do not turn the switch to off, the engine speed may be increased when the engine is started.

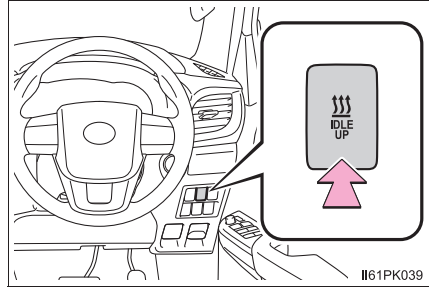

Air outlets

■ Location of air outlets

The air outlets and air volume changes according to the selected air flow mode.

← : Some models

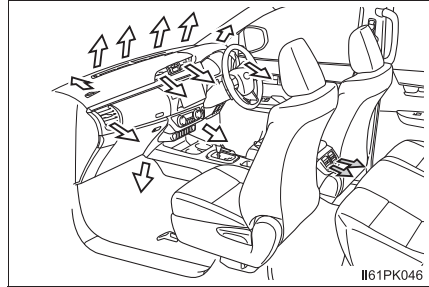

■ Adjusting the air flow direction and opening/closing the air outlets

▶ Center outlets

- ① Direct air flow to the left or right, up or down.
- ② Close the vents.

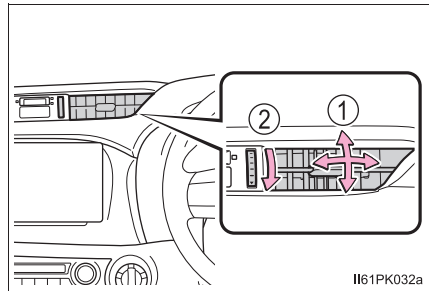

▶ Side outlets

- ① Direct air flow to the left or right, up or down.
- ② Close the vents.

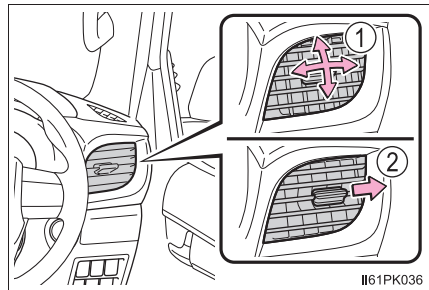

► Rear outlets

- ① Direct air flow to the left or right, up or down.
- ② Close the vents.

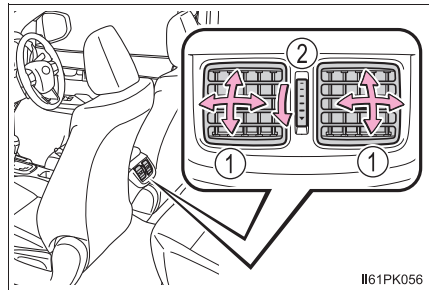

■ Using automatic mode

Fan speed is adjusted automatically according to the temperature setting and the ambient conditions.

Therefore, the fan may stop for a while until warm or cool air is ready to flow immediately after  is pressed.

■ Fogging up of the windows

- The windows will easily fog up when the humidity in the vehicle is high.

Turning  on will dehumidify the air from the outlets and defog the windshield effectively.

- If you turn  off, the windows may fog up more easily.
- The windows may fog up if the recirculated air mode is used.

■ When driving on dusty roads

Close all windows. If dust thrown up by the vehicle is still drawn into the vehicle after closing the windows, it is recommended that the air intake mode be set to outside air mode and the fan speed to any setting except off.

■ Outside/recirculated air mode

- Setting to the recirculated air mode temporarily is recommended in preventing dirty air from entering the vehicle interior and helping to cool the vehicle when the outside air temperature is high.
- Outside/recirculated air mode may automatically switch depending on the temperature setting or the inside temperature.

■ Operation of the air conditioning system in Eco drive mode (if equipped)

- In Eco drive mode, the air conditioning system is controlled as follows to prioritize fuel efficiency:
 - Engine speed and compressor operation controlled to restrict heating/cooling capacity
 - Fan speed restricted when automatic mode is selected
- To improve air conditioning performance, perform the following operations.
 - Adjust the fan speed
 - Turn off Eco drive mode
 - Adjust the temperature setting

■ When the outside temperature falls to nearly 0°C (32°F)

The dehumidification function may not operate even when  is pressed.

■ Ventilation and air conditioning odors

- To let fresh air in, set the air conditioning system to the outside air mode.
- During use, various odors from inside and outside the vehicle may enter into and accumulate in the air conditioning system. This may then cause odor to be emitted from the vents.
- To reduce potential odors from occurring:
 - It is recommended that the air conditioning system be set to outside air mode prior to turning the vehicle off.
 - The start timing of the blower may be delayed for a short period of time immediately after the air conditioning system is started in automatic mode.

■ Air conditioning filter

→P. 371

⚠ WARNING**■ To prevent the windshield from fogging up**

- Do not use  during cool air operation in extremely humid weather. The difference between the temperature of the outside air and that of the windshield can cause the outer surface of the windshield to fog up, blocking your vision.
- Do not place anything on the instrument panel which may cover the air outlets. Otherwise, air flow may be obstructed, preventing the windshield defoggers from defogging.

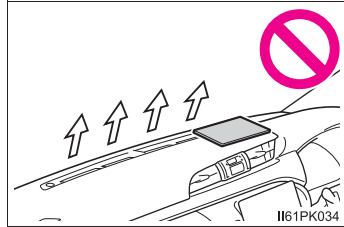
**■ To prevent burns (vehicles with outside rear view mirror defoggers)**

Do not touch the rear view mirror surfaces when the outside rear view mirror defoggers are on.

⚠ NOTICE**■ To prevent battery discharge**

Do not leave the air conditioning system on longer than necessary when the engine is off.

Seat heaters*

- ① Turns on the front left seat heater
The indicator light comes on.
- ② Turns on the front right seat heater
The indicator light comes on.

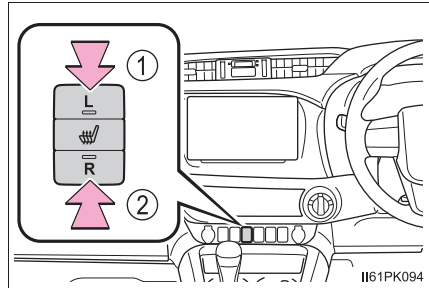

- The seat heaters can be used when the engine switch is in IGNITION ON mode.
- When not in use, press the seat heater switch to turn the seat heater off. The indicator light turns off.

WARNING

- Care should be taken to prevent injury if anyone in the following categories comes in contact with the seats when the heater is on:
 - Babies, small children, the elderly, the sick and the physically challenged
 - Persons with sensitive skin
 - Persons who are fatigued
 - Persons who have taken alcohol or drugs that induce sleep (sleeping drugs, cold remedies, etc.)
- Observe the following precautions to prevent minor burns or overheating:
 - Do not cover the seat with a blanket or cushion when using the seat heater.
 - Do not use seat heater more than necessary.

NOTICE

- Do not put heavy objects that have an uneven surface on the seat and do not stick sharp objects (needles, nails, etc.) into the seat.
- To prevent battery discharge, do not use the functions when the engine is not running.

Interior lights list

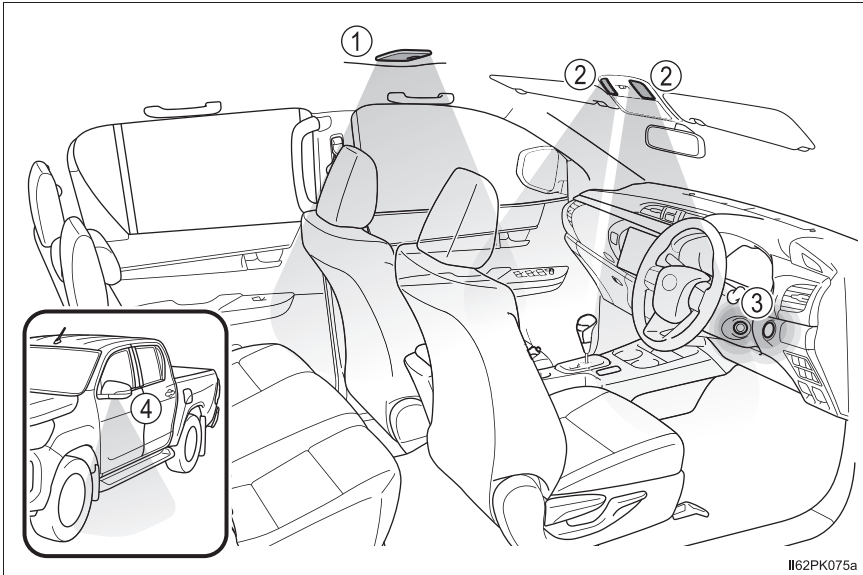

- ① Interior light (if equipped) (→P. 321)
- ② Personal/interior lights (→P. 321)
- ③ Engine switch light
- ④ Outer foot lights (if equipped)

Personal/interior light main switch

① Door position

The personal/interior lights come on when a door is opened. They turn off when the doors are closed.

② Off

The personal/interior lights can be individually turned on or off.

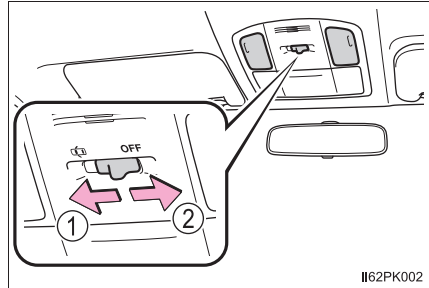

I162PK002

Personal/interior lights

On/off

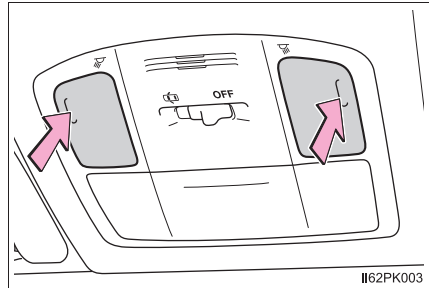

I162PK003

Interior light (if equipped)

① Off

② Door position

The interior light comes on when a door is opened. It turns off when the doors are closed.

③ On

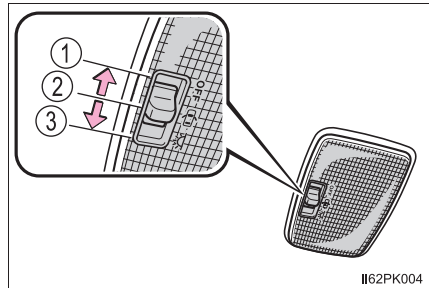

I162PK004

- Illuminated entry system (if equipped):
 - ▶ Vehicles without smart entry & start system
The lights automatically turn on/off according to the engine switch position, whether the doors are locked/unlocked, and whether the doors are opened/closed.
 - ▶ Vehicles with smart entry & start system
The lights automatically turn on/off according to engine switch mode, whether the doors are locked/unlocked, and whether the doors are opened/closed.
- If the following lights remain on when the engine switch is turned to the “LOCK” position (vehicles without smart entry & start system) or off (vehicles with smart entry & start system), the lights will go off automatically after 20 minutes:
 - Personal/interior light
 - Interior light (if equipped)
 - Engine switch light

**NOTICE**

To prevent battery discharge, do not leave the lights on longer than necessary when the engine is not running.

List of storage features

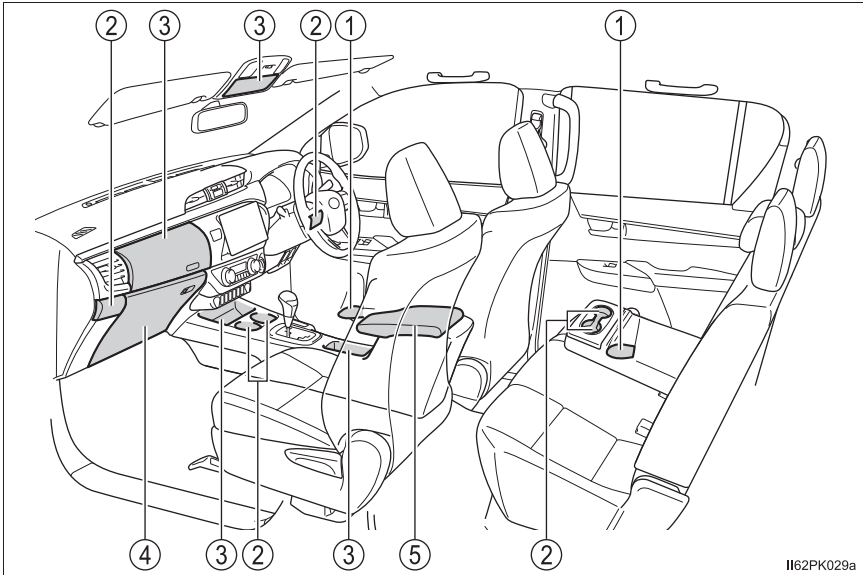

- | | |
|---|--|
| ① Bottle holders (if equipped)
(→P. 326) | ③ Auxiliary boxes (if equipped)
(→P. 327) |
| ② Cup holders (if equipped)
(→P. 325) | ④ Glove box
(→P. 324) |
| | ⑤ Console box (if equipped)
(→P. 324) |

⚠ WARNING

- Do not leave glasses, lighters or spray cans in the storage spaces, as this may cause the following when cabin temperature becomes high:
 - Glasses may be deformed by heat or cracked if they come into contact with other stored items.
 - Lighters or spray cans may explode. If they come into contact with other stored items, the lighter may catch fire or the spray can may release gas, causing a fire hazard.
- When driving or when the glove box and the console box are not in use, keep it closed.
In the event of sudden braking or sudden swerving, an accident may occur due to an occupant being struck by an open lid or the items stored inside.

Glove box

- ① Open (push button)
- ② Unlock with the master key or the mechanical key
- ③ Lock with the master key or the mechanical key

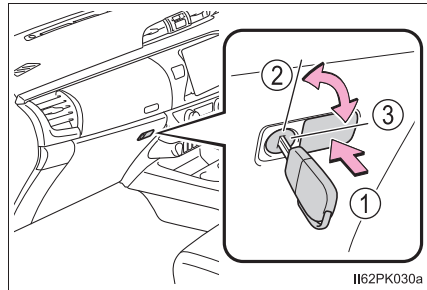

Console box (if equipped)

Lift the lid while pulling up the knob to release the lock.

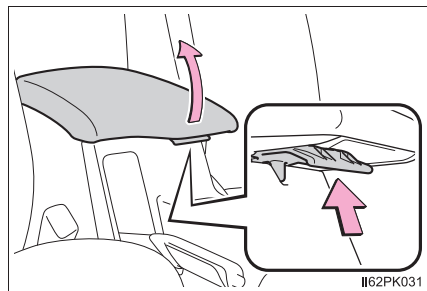

Cup holders

▶ Type A

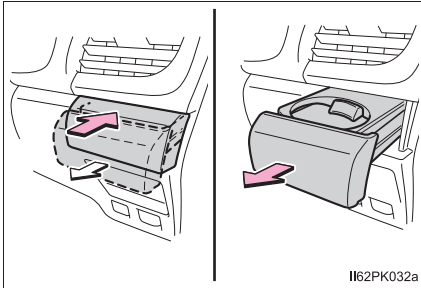

▶ Type B (if equipped)

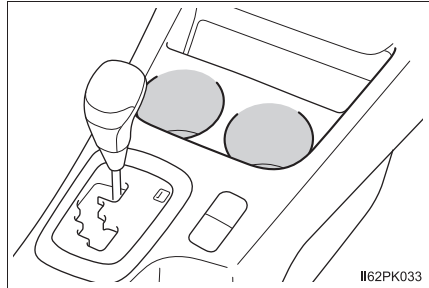

Press in and pull the cup holder.

▶ Type C (if equipped)

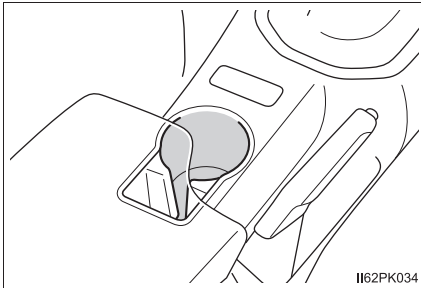

▶ Type D (if equipped)

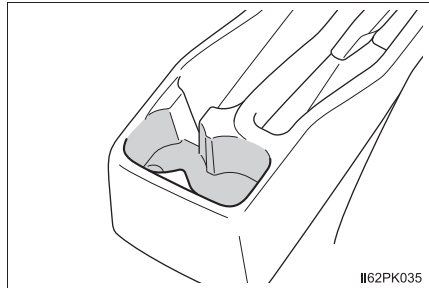

▶ Type E (if equipped)

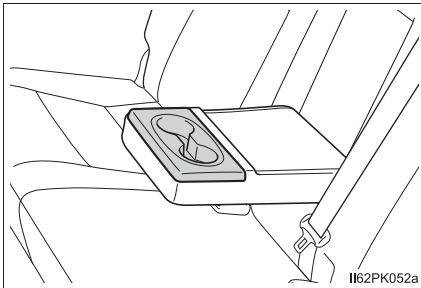

Pull the armrest down.

⚠ WARNING

Do not place anything other than cups or beverage cans in the cup holders. Even when the lid is closed, items must not be stored in the cup holders. Other items may be thrown out of the holders in the event of sudden braking, sudden swerving or an accident, cause injury. If possible, cover hot drinks to prevent burns.

Bottle holders

► For front seats

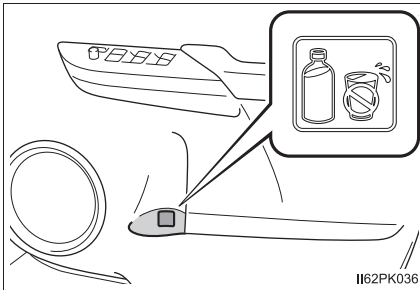

► For rear seats (if equipped)

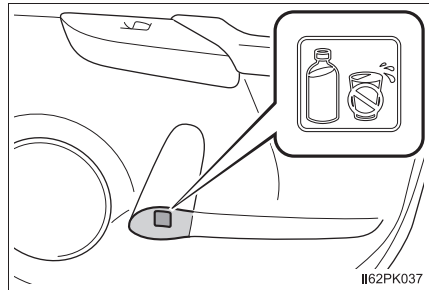

- When using the holder as a bottle holder:
 - When storing a bottle, close the cap.
 - The bottle may not be stored depending on its size or shape.

⚠ WARNING

Do not place anything other than a bottle in the bottle holders. Other items may be thrown out of the holders in the event of an accident or sudden braking and cause injury.

⚠ NOTICE

Do not place open bottles or glass and paper cups containing liquid in the bottle holders. The contents may spill and glasses may break.

Auxiliary boxes

► Type A

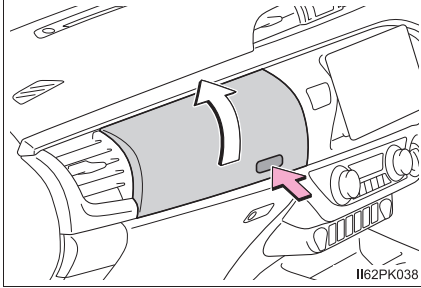

Press the button.

► Type C

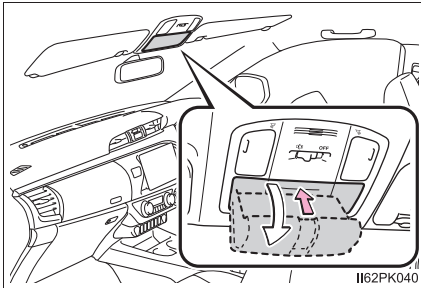

Press in the lid.

The auxiliary box is useful for temporarily storing sunglasses and similar small items.

► Type E (if equipped)

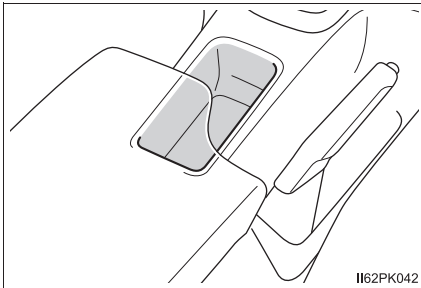

► Type B

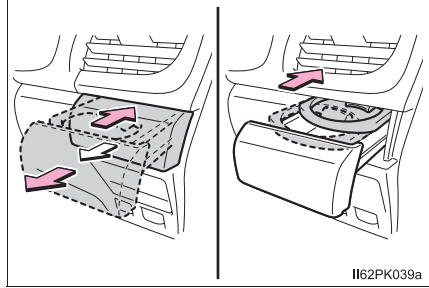

Press in and pull the cup holder, and push the cup tray.

► Type D*

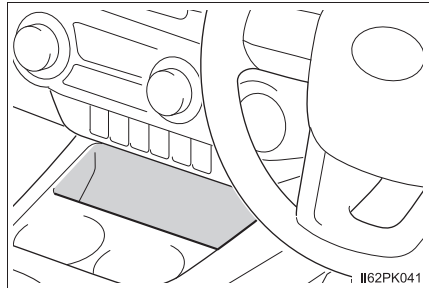

► Type F (if equipped)

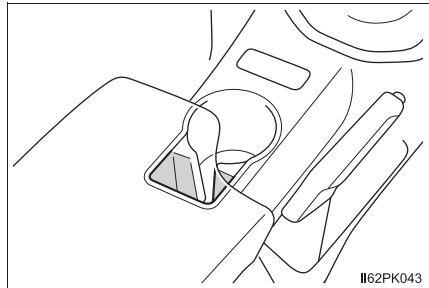

► Type G (if equipped)

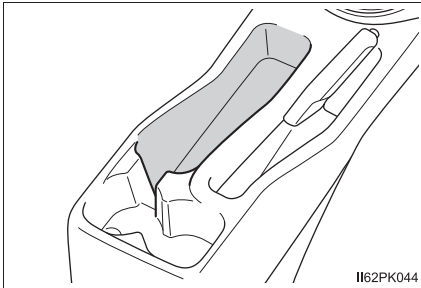

*: The shape of the auxiliary box may differ depending on the grade, etc.

- Air conditioning-linked temperature regulation function (type A) (if equipped):



By introducing air from the air conditioning system into the auxiliary box, canned drinks etc. can be kept hot or cold. However, as the temperature inside the auxiliary box will become the same as the temperature of the air flowing from the air conditioning system, extreme heating and cooling are not possible. In high humidity condition, be careful of objects inside the auxiliary box, as condensation may form.

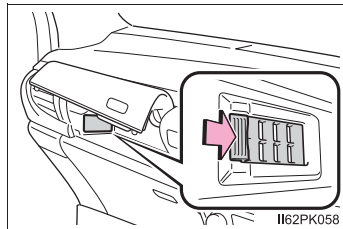

- Using the air conditioning-linked temperature regulation function (type A) (if equipped):

- 1 Open the air intake lid inside the auxiliary box.

To blow a large amount of air into the auxiliary box, close the passenger side vent. (→P. 308, 315)



- 2 Allow the air conditioning system to operate, and use  or  to

select either  or . (→P. 306, 312)

- 3 Adjust the temperature. (→P. 306, 311)

- Normal use (type A) (if equipped):

Close the air intake lid inside the auxiliary box.

- Items unsuitable for the auxiliary box (type A) (if equipped):

- Drinks in unsealed container
- Fragile items, perishables or anything with strong odor

 **WARNING**

- Do not store items heavier than 0.2 kg (0.4 lb.).
Doing so may cause the auxiliary box to open and the items inside may fall out, resulting in an accident. (type C)
- Keep the auxiliary boxes closed. In the event of sudden braking, an accident may occur due to an occupant being struck by an open auxiliary box or the items stored inside. (type A, B and C)
- When using the auxiliary boxes, do not use the cup tray.
If a cup, aluminum can or bottle is placed in the auxiliary box, it may be thrown out of the box in the event of an accident or sudden braking, resulting in injury. (type B)

Other interior features

Sun visors

- ① To set the visor in the forward position, flip it down.
- ② To set the visor in the side position, flip down, unhook, and swing it to the side.

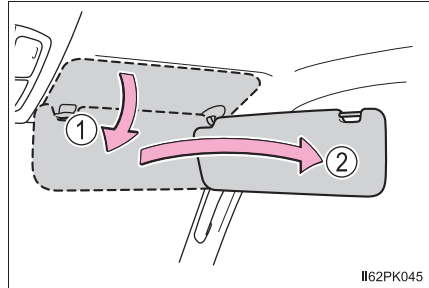

Vanity mirror (if equipped)

Open the cover to use.

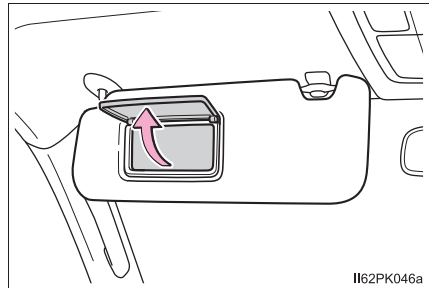

Clock

The clock can be adjusted by pressing the buttons.

- ① Adjusts the hours
- ② Adjusts the minutes
- ③ Rounds to the nearest hour*

*: e.g. 1:00 to 1:29 → 1:00
1:30 to 1:59 → 2:00

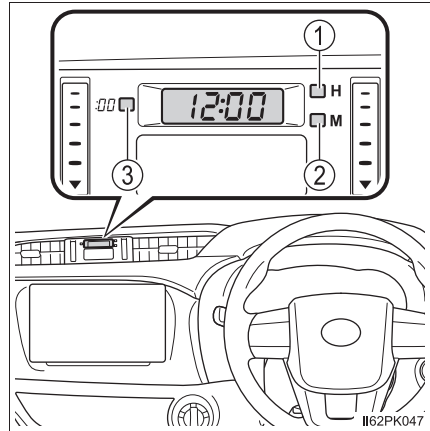

- The clock is displayed when:
 - ▶ Vehicles without smart entry & start system
The engine switch is in the "ACC" or "ON" position.
 - ▶ Vehicles with smart entry & start system
The engine switch is in ACCESSORY or IGNITION ON mode.
- When disconnecting and reconnecting battery terminals:
The time display will automatically be set to 1:00.

Power outlets (if equipped)

The power outlet can be used for the following components:

12 V DC:

Please use as a power supply for electronic goods that use less than 12 V DC / 10 A (power consumption of 120 W).

When using electronic goods, make sure that the power consumption of all the connected power outlets is less than 120 W.

220 V AC:

Accessories that use less than 100 W.

■ 12 V DC

Open the cover.

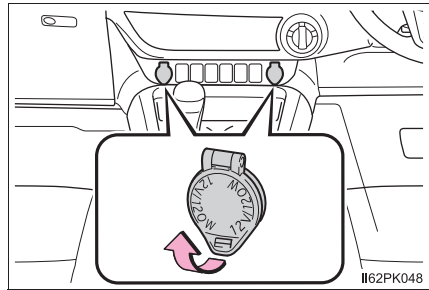

■ 220 V AC

Open the cover.

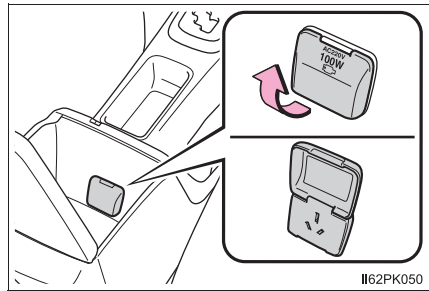

- The power outlet can be used when:
 - ▶ Vehicles without smart entry & start system
12 V DC: The engine switch is in the “ACC” or “ON” position.
 - ▶ Vehicles with smart entry & start system
12 V DC: The engine switch is in ACCESSORY or IGNITION ON mode.
220 V AC: The engine switch is in IGNITION ON mode.
- When turning the engine switch off:
Disconnect electrical devices with charging functions, such as mobile battery packs.
If such devices are left connected, the engine switch may not be turned off normally.

**NOTICE**

- To avoid damaging the power outlets, close the power outlet lid when the power outlet is not in use.
Foreign objects or liquids that enter the power outlet may cause a short circuit.
- To prevent blown fuse:
 - ▶ 12 V DC
Do not use an accessory that uses more than 12 V 10 A.
 - ▶ 220 V AC
Do not use a 220 V AC appliance that requires more than 100 W.
If a 220 V AC appliance that consumes more than 100 W is used, the protection circuit will cut the power supply.
- To prevent battery discharge, do not use the power outlet longer than necessary when the engine is not running.
- The following 220 V AC appliances may not operate properly even if their power consumption is under 100 W:
 - Appliances with high initial peak wattage
 - Measuring devices that process precise data
 - Other appliances that require an extremely stable power supply

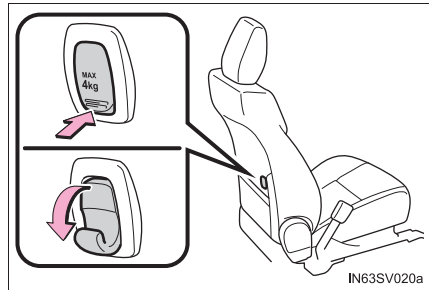
Grocery bag hooks (if equipped)**⚠ WARNING**

Keep the hooks returned in place when not in use.

⚠ NOTICE

Do not hang any object heavier than 4 kg (8.8 lb.).

Coat hooks (if equipped)

The coat hooks are provided above the back window.

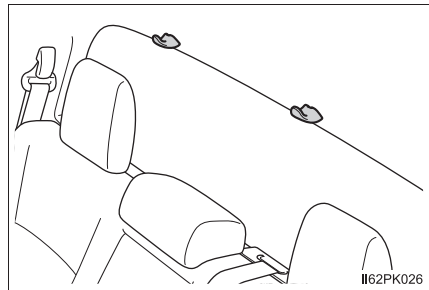

Armrest (if equipped)

Fold down the armrest for use.

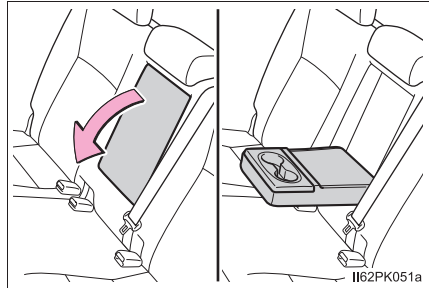
 **NOTICE**

To prevent damage to the armrest, do not apply too much load on the armrest.

6-1. Maintenance and care	
Cleaning and protecting the vehicle exterior	338
Cleaning and protecting the vehicle interior	342
6-2. Maintenance	
Maintenance requirements.....	345
6-3. Do-it-yourself maintenance	
Do-it-yourself service precautions	347
Hood	349
Engine compartment.....	351
Tires.....	364
Tire inflation pressure	367
Wheels.....	369
Air conditioning filter	371
Wireless remote control/ electronic key battery.....	373
Checking and replacing fuses	376
Light bulbs	381

Cleaning and protecting the vehicle exterior

Perform the following to protect the vehicle and maintain it in prime condition:

- Working from top to bottom, liberally apply water to the vehicle body, wheel wells and underside of the vehicle to remove any dirt and dust.
- Wash the vehicle body using a sponge or soft cloth, such as a chamois.
- For hard-to-remove marks, use car wash soap and rinse thoroughly with water.
- Wipe away any water.
- Wax the vehicle when the waterproof coating deteriorates.

If water does not bead on a clean surface, apply wax when the vehicle body is cool.

■ Automatic car washes

- Fold the mirrors and remove the antenna before washing the vehicle. Start washing from the front of the vehicle. Make sure to re-install the antenna and extend the mirrors before driving.
- Brushes used in automatic car washes may scratch the vehicle surface, parts (wheel, etc.) and harm your vehicle's paint.

■ High pressure car washes

As water may enter the cabin, do not bring the nozzle tip near the gaps around the doors or perimeter of the windows, or spray these areas continuously.

■ Wheels and wheel ornaments

- Remove any dirt immediately by using a neutral detergent.
- Wash detergent off with water immediately after use.
- To protect the paint from damage, make sure to observe the following precautions.
 - Do not use acidic, alkaline or abrasive detergent
 - Do not use hard brushes
 - Do not use detergent on the wheels when they are hot, such as after driving or parking in hot weather

■ White letter on the sidewall of the tire (if equipped)

It is recommended to frequently clean, as it can easily get dirty. When cleaning it, use the sponge and car wash soap.

■ Brake

Rust may form if the vehicle is parked with wet brake pads or disc rotors, causing noises or vibrations. Before parking the vehicle after it is washed, drive slowly and apply the brakes several times to dry the parts.

■ Bumpers

Do not scrub with abrasive cleaners.

■ Plated portions

If dirt cannot be removed, clean the parts as follows:

- Use a soft cloth dampened with an approximately 5% solution of neutral detergent and water to clean the dirt off.
- Wipe the surface with a dry, soft cloth to remove any remaining moisture.
- To remove oily deposits, use alcohol wet wipes or a similar product.



WARNING

■ When washing the vehicle

Do not apply water to the inside of the engine compartment. Doing so may cause the electrical components etc. to catch fire.

■ Precautions regarding the exhaust pipe

Exhaust gasses cause the exhaust pipe to become quite hot.

When washing the vehicle, be careful not to touch the pipe until it has cooled sufficiently, as touching a hot exhaust pipe can cause burns.

**NOTICE****■ To prevent paint deterioration and corrosion on the body and components (aluminum wheels etc.)**

- Wash the vehicle immediately in the following cases:
 - After driving near the sea coast
 - After driving on salted roads
 - If coal tar or tree sap is present on the paint surface
 - If dead insects, insect droppings or bird droppings are present on the paint surface
 - After driving in an area contaminated with soot, oily smoke, mine dust, iron powder or chemical substances
 - If the vehicle becomes heavily soiled with dust or mud
 - If liquids such as benzene and gasoline are spilled on the paint surface
- If the paint is chipped or scratched, have it repaired immediately.
- To prevent the wheels from corroding, remove any dirt and store in a place with low humidity when storing the wheels.

■ Cleaning the exterior lights

- Wash carefully. Do not use organic substances or scrub with a hard brush. This may damage the surfaces of the lights.
- Do not apply wax to the surfaces of the lights. Wax may cause damage to the lenses.

■ Antenna installation and removal precautions

- Before driving, ensure that the antenna is installed.
- When the antenna is removed, such as before entering an automatic car wash, make sure to store it in a suitable place so as not to lose it. Also, before driving, make sure to reinstall the antenna in its original position.

**NOTICE****■ When using a high pressure car wash**

- Do not bring the nozzle tip close to boots (rubber or resin manufactured cover), connectors or the following parts. The parts may be damaged if they come into contact with high-pressure water.
 - Traction related parts
 - Steering parts
 - Suspension parts
 - Brake parts
- Keep the cleaning nozzle at least 30 cm (11.9 in.) away from the vehicle body. Otherwise resin section, such as moldings and bumpers, may be deformed and damaged. Also, do not continuously hold the nozzle in the same place.
- Do not spray the lower part of the windshield continuously.
If water enters the air conditioning system intake located near the lower part of the windshield, the air conditioning system may not operate correctly.

Cleaning and protecting the vehicle interior

The following procedures will help protect your vehicle's interior and keep it in top condition:

Protecting the vehicle interior

- Remove dirt and dust using a vacuum cleaner. Wipe dirty surfaces with a cloth dampened with lukewarm water.
- If dirt cannot be removed, wipe it off with a soft cloth dampened with neutral detergent diluted to approximately 1%.
- Wring out any excess water from the cloth and thoroughly wipe off remaining traces of detergent and water.

Cleaning the leather areas

- Remove dirt and dust using a vacuum cleaner.
- Wipe off any excess dirt and dust with a soft cloth dampened with diluted detergent.
Use a diluted water solution of approximately 5% neutral wool detergent.
- Wring out any excess water from the cloth and thoroughly wipe off all remaining traces of detergent.
- Wipe the surface with a dry, soft cloth to remove any remaining moisture. Allow the leather to dry in a shaded and ventilated area.

Cleaning the synthetic leather areas

- Remove dirt and dust using a vacuum cleaner.
- Wipe it off with a soft cloth dampened with neutral detergent diluted to approximately 1%.
- Wring out any excess water from the cloth and thoroughly wipe off remaining traces of detergent and water.

■ Caring for leather areas

Toyota recommends cleaning the interior of the vehicle at least twice a year to maintain the quality of the vehicle's interior.

■ Shampooing the carpets

There are several commercial foaming-type cleaners available. Use a sponge or brush to apply the foam. Rub in overlapping circles. Do not use water. Wipe dirty surfaces and let them dry. Excellent results are obtained by keeping the carpet as dry as possible.

■ Seat belts

Clean with mild soap and lukewarm water using a cloth or sponge. Also check the belts periodically for excessive wear, fraying or cuts.

**WARNING****■ Water in the vehicle**

- Do not splash or spill liquid in the vehicle.
Doing so may cause electrical components etc. to malfunction or catch fire.
- Do not get any of the SRS components or wiring in the vehicle interior wet. (→P. 36)
An electrical malfunction may cause the airbags to deploy or not function properly, resulting in death or serious injury.

■ Cleaning the interior (especially instrument panel)

Do not use polish wax or polish cleaner. The instrument panel may reflect off the windshield, obstructing the driver's view and leading to an accident, resulting in death or serious injury.

**NOTICE****■ Cleaning detergents**

- Do not use the following types of detergent, as they may discolor the vehicle interior or cause streaks or damage to painted surfaces:
 - Non-seat portions: Organic substances such as benzene or gasoline, alkaline or acidic solutions, dye, and bleach
 - Seats: Alkaline or acidic solutions, such as thinner, benzene, and alcohol
- Do not use polish wax or polish cleaner. The instrument panel's or other interior part's painted surface may be damaged.

■ Preventing damage to leather surfaces

Observe the following precautions to avoid damage to and deterioration of leather surfaces:

- Remove any dust or dirt from leather surfaces immediately.
- Do not expose the vehicle to direct sunlight for extended periods of time. Park the vehicle in the shade, especially during summer.
- Do not place items made of vinyl, plastic, or containing wax on the upholstery, as they may stick to the leather surface if the vehicle interior heats up significantly.

■ Water on the floor

Do not wash the vehicle floor with water.

Vehicle systems such as the audio system may be damaged if water comes into contact with electrical components such as the audio system above or under the floor of the vehicle. Water may also cause the body to rust.

■ When cleaning the inside of the windshield

Do not allow glass cleaner to contact the lens. Also, do not touch the lens.
(→P. 214)

■ Cleaning the inside of the rear window

- Do not use glass cleaner to clean the rear window, as this may cause damage to the rear window defogger heater wires. Use a cloth dampened with lukewarm water to gently wipe the window clean. Wipe the window in strokes running parallel to the heater wires.
- Be careful not to scratch or damage the heater wires.

Maintenance requirements

To ensure safe and economical driving, day-to-day care and regular maintenance are essential. Toyota recommends the following maintenance:

Scheduled maintenance

Scheduled maintenance should be performed at specified intervals according to the maintenance schedule.

For full details of your maintenance schedule, refer to the “Warranty and Service Booklet”.

Do-it-yourself maintenance

What about do-it-yourself maintenance?

Many maintenance items are easy to do yourself if you have a little mechanical ability and a few basic automotive tools.

Note, however, that some maintenance tasks require special tools and skills. These are best performed by qualified technicians. Even if you are an experienced do-it-yourself mechanic, we recommend that repairs and maintenance be conducted by your Toyota dealer who will keep a record of maintenance on your vehicle. This record could be helpful should you ever require Warranty Service.

■ Where to go for maintenance service?

It makes good sense to take your vehicle to your local Toyota dealer for maintenance service as well as other inspections and repairs.

Toyota technicians are well-trained specialists receiving the latest service information through technical bulletins, service tips, and in-dealership training programs. They learn to work on Toyota before they work on your vehicle, rather than while they are working on it. Doesn't that seem like the best way?

Your Toyota dealer has invested a lot of money in special Toyota tools and service equipment. It helps them to do the job better and at less cost.

Your Toyota dealer's service department will perform all of the scheduled maintenance on your vehicle reliably and economically.

■ Does your vehicle need repairs?

Be on the alert for changes in performance and sounds, and visual tip-offs that indicate service is needed. Some important clues are:

- Engine missing, stumbling or pinging
- Appreciable loss of power
- Strange engine noises
- A fluid leak under the vehicle (However, water dripping from the air conditioning system after use is normal.)
- Change in exhaust sound (This may indicate a dangerous carbon monoxide leak. Drive with the windows open and have the exhaust system checked immediately.)
- Flat-looking tires, excessive tire squeal when cornering, uneven tire wear
- Vehicle pulls to one side when driven straight on a level road
- Strange noises related to suspension movement
- Loss of brake effectiveness, spongy feeling brake pedal or clutch pedal, pedal almost touches the floor, vehicle pulls to one side when braking
- Engine coolant temperature continually higher than normal

If you notice any of these clues, take your vehicle to your Toyota dealer as soon as possible. Your vehicle may need adjustment or repair.



WARNING

■ If your vehicle is not properly maintained

Improper maintenance could result in serious damage to the vehicle and possible serious injury or death.

■ Handling of the battery

Battery posts, terminals and related accessories contain lead and lead compounds which are known to cause brain damage. Wash your hands after handling. (→P. 358)

Do-it-yourself service precautions

If you perform maintenance by yourself, be sure to follow the correct procedure as given in these sections.

Items	Parts and tools
Battery condition (→P. 358)	<ul style="list-style-type: none"> • Warm water • Baking soda • Grease • Conventional wrench (for terminal clamp bolts) • Distilled water
Engine coolant level (→P. 356)	<ul style="list-style-type: none"> • “Toyota Super Long Life Coolant” or a similar high quality ethylene glycol-based non-silicate, non-amine, non-nitrite and non-borate coolant with long-life hybrid organic acid technology “Toyota Super Long Life Coolant” is pre-mixed with 50% coolant and 50% deionized water. • Funnel (used only for adding coolant)
Engine oil level (→P. 353)	<ul style="list-style-type: none"> • “Toyota Genuine Motor Oil” or equivalent • Rag or paper towel • Funnel (used only for adding engine oil)
Fuses (→P. 376)	<ul style="list-style-type: none"> • Fuse with same amperage rating as original
Light bulbs (→P. 381)	<ul style="list-style-type: none"> • Bulb with same number and wattage rating as original • Phillips-head screwdriver • Flathead screwdriver • Wrench
Radiator, condenser and intercooler (if equipped) (→P. 358)	—
Tire inflation pressure (→P. 367)	<ul style="list-style-type: none"> • Tire pressure gauge • Compressed air source
Washer fluid (→P. 362)	<ul style="list-style-type: none"> • Water or washer fluid containing antifreeze (for winter use) • Funnel (used only for adding water or washer fluid)

 **WARNING**

The engine compartment contains many mechanisms and fluids that may move suddenly, become hot, or become electrically energized. To avoid death or serious injury, observe the following precautions.

■ When working on the engine compartment

- Keep hands, clothing and tools away from the moving fan and engine drive belt.
- Be careful not to touch the engine, radiator, exhaust manifold, etc. right after driving as they may be hot. Oil and other fluids may also be hot.
- Do not leave anything that may burn easily, such as paper and rags, in the engine compartment.
- Do not smoke, cause sparks or expose an open flame to fuel or the battery. Fuel and battery fumes are flammable.
- Be extremely cautious when working on the battery. It contains poisonous and corrosive sulfuric acid.
- Take care because brake fluid can harm your hands or eyes and damage painted surfaces. If fluid gets on your hands or in your eyes, flush the affected area with clean water immediately.
If you still experience discomfort, consult a doctor.

■ Safety glasses

Wear safety glasses to prevent flying or falling material, fluid spray, etc. from getting in your eyes.

 **NOTICE****■ If you remove the air cleaner filter**

Driving with the air cleaner filter removed may cause excessive engine wear due to dirt in the air.

■ If the fluid level is low or high

It is normal for the brake fluid level to go down slightly as the brake pads wear or when the fluid level in the accumulator is high.

If the reservoir needs frequent refilling, it may indicate a serious problem.

Hood

Release the lock from the inside of the vehicle to open the hood.

- 1 Pull the hood lock release lever.
The hood will pop up slightly.

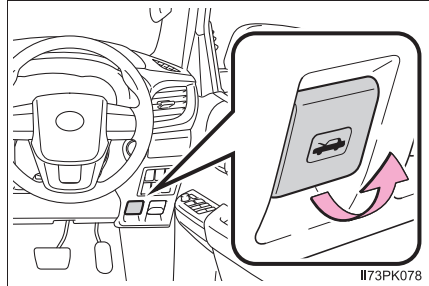

- 2 Pull up the auxiliary catch lever and lift the hood.

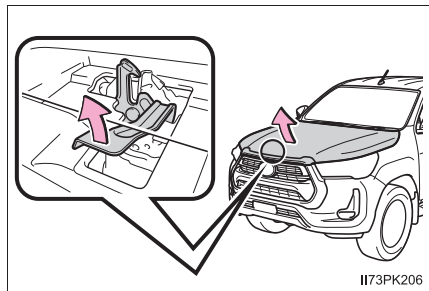

- 3 Hold the hood open by inserting the supporting rod into either of the slots.

Use the upper slots to open the hood normally, or use the lower slots when the hood needs to be opened wide.

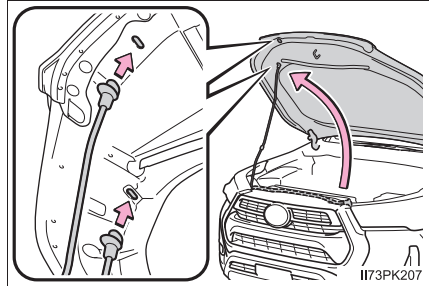

 **WARNING****■ Pre-driving check**

Check that the hood is fully closed and locked.

If the hood is not locked properly, it may open while the vehicle is in motion and cause an accident, which may result in death or serious injury.

■ After installing the support rod into the slot

Make sure the rod supports the hood securely from falling down on to your head or body.

 **NOTICE****■ When closing the hood**

Be sure to return the support rod to its clip before closing the hood. Closing the hood with the support rod up could cause the hood to bend.

Engine compartment

► Gasoline engine

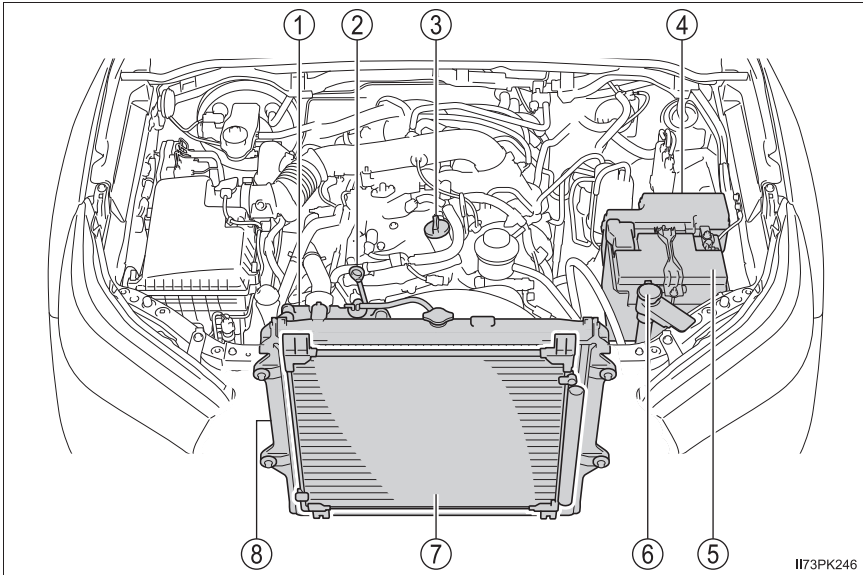

I173PK246

- | | |
|--|-------------------------------|
| ① Engine coolant reservoir
(→P. 356) | ④ Fuse box
(→P. 376) |
| ② Engine oil level dipstick
(→P. 353) | ⑤ Battery
(→P. 358) |
| ③ Engine oil filler cap (→P. 354) | ⑥ Washer fluid tank (→P. 362) |
| | ⑦ Condenser
(→P. 358) |
| | ⑧ Radiator
(→P. 358) |

▶ Diesel engine

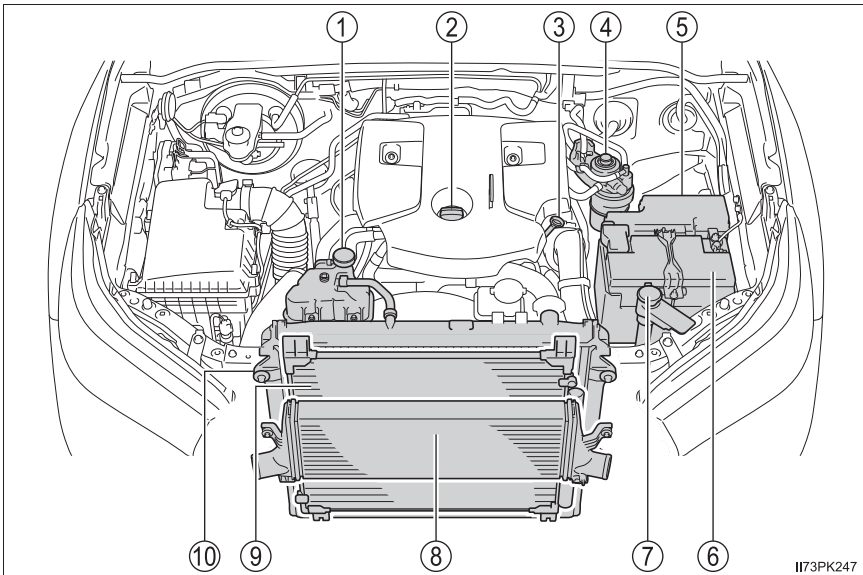

I173PK247

- | | |
|--|-------------------------------|
| ① Engine coolant reservoir
(→P. 356) | ⑤ Fuse box
(→P. 376) |
| ② Engine oil filler cap (→P. 354) | ⑥ Battery (→P. 358) |
| ③ Engine oil level dipstick
(→P. 353) | ⑦ Washer fluid tank (→P. 362) |
| ④ Fuel filter (→P. 363, 462) | ⑧ Intercooler (→P. 358) |
| | ⑨ Condenser (→P. 358) |
| | ⑩ Radiator (→P. 358) |

Engine oil

With the engine at operating temperature and turned off, check the oil level on the dipstick.

■ Checking the engine oil

- 1 Park the vehicle on level ground. After warming up the engine and turning it off, wait more than 5 minutes for the oil to drain back into the bottom of the engine.
- 2 Remove the sand and dust from around the dipstick.
- 3 Holding a rag under the end, pull the dipstick out.

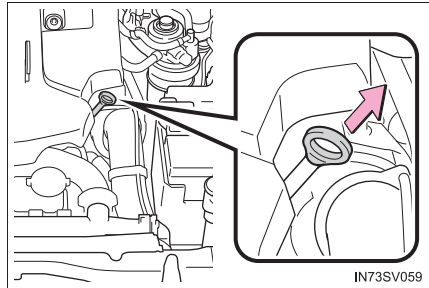

- 4 Wipe the dipstick clean.

Make sure that the inlet of the oil level gauge guide and O-ring of the dipstick are free from sand and dust.

If the O-ring is damaged, replace it with a new one.

- 5 Reinsert the dipstick fully.
- 6 Holding a rag under the end, pull the dipstick out and check the oil level.

- ① Low
- ② Normal
- ③ Excessive

The shape of the dipstick may differ depending on the type of vehicle or engine.

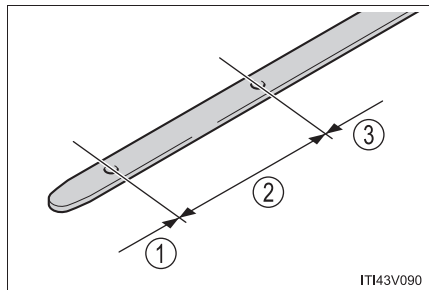

- 7 Wipe the dipstick and reinsert it fully.

■ Adding engine oil

If the oil level is below or near the low level mark, add engine oil of the same type as that already in the engine.

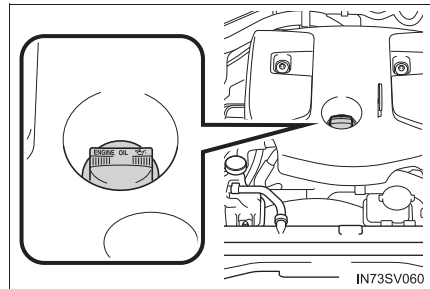

Make sure to check the oil type and prepare the items needed before adding oil.

Engine oil selection	→P. 471
Oil quantity (Low → Full)	1.5 L (1.6 qt., 1.3 Imp.qt.)
Items	Clean funnel

- 1 Remove the sand and dust from around the oil filler cap.
- 2 Remove the oil filler cap by turning it counterclockwise.
- 3 Add engine oil slowly, checking the dipstick.
- 4 Install the oil filler cap by turning it clockwise.

■ Engine oil consumption

A certain amount of engine oil will be consumed while driving. In the following situations, oil consumption may increase, and engine oil may need to be refilled in between oil maintenance intervals.

- When the engine is new, for example directly after purchasing the vehicle or after replacing the engine
- If low quality oil or oil of an inappropriate viscosity is used
- When driving at high engine speeds or with a heavy load, when towing, or when driving while accelerating or decelerating frequently
- When leaving the engine idling for a long time, or when driving frequently through heavy traffic

 **WARNING****■ Used engine oil**

- Used engine oil contains potentially harmful contaminants which may cause skin disorders such as inflammation and skin cancer, so care should be taken to avoid prolonged and repeated contact. To remove used engine oil from your skin, wash thoroughly with soap and water.
- Dispose of used oil and filters only in a safe and acceptable manner. Do not dispose of used oil and filters in household trash, in sewers or onto the ground. Call your Toyota dealer, service station or auto parts store for information concerning recycling or disposal.
- Do not leave used engine oil within the reach of children.

 **NOTICE****■ To prevent serious engine damage**

Check the oil level on a regular basis.

■ When replacing the engine oil

- Be careful not to spill engine oil on the vehicle components.
- Avoid overfilling, or the engine could be damaged.
- Check the oil level on the dipstick every time you refill the vehicle.
- Be sure the engine oil filler cap is properly tightened.

Engine coolant

The coolant level is satisfactory if it is between the “F” and “L” lines on the reservoir when the engine is cold.

▶ Gasoline engine

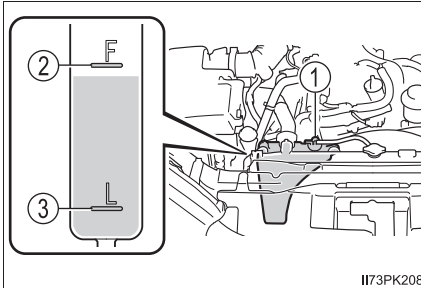

▶ Diesel engine

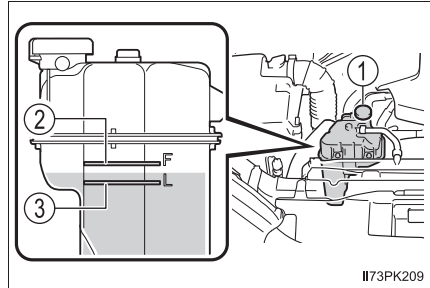

① Reservoir cap

② “F” line

③ “L” line

If the level is on or below the “L” line, add coolant up to the “F” line.
(→P. 459)

■ Coolant selection

Only use “Toyota Super Long Life Coolant” or a similar high quality ethylene glycol based non-silicate, non-amine, non-nitrite, and non-borate coolant with long-life hybrid organic acid technology.

“Toyota Super Long Life Coolant” is a mixture of 50% coolant and 50% deionized water. (Minimum temperature: -35°C [-31°F])

For more details about engine coolant, contact your Toyota dealer.

■ If the coolant level drops within a short time of replenishing

Visually check the radiator, hoses, engine coolant reservoir cap, drain cock and water pump. If you cannot find a leak, have your Toyota dealer test the cap and check for leaks in the cooling system.



WARNING

■ When the engine is hot

Do not remove the radiator cap or the coolant reservoir cap.

The cooling system may be under pressure and may spray hot coolant if the cap is removed, causing serious injuries, such as burns.



NOTICE

■ When adding coolant

Coolant is neither plain water nor straight antifreeze. The correct mixture of water and antifreeze must be used to provide proper lubrication, corrosion protection and cooling. Be sure to read the antifreeze or coolant label.

■ If you spill coolant

Be sure to wash it off with water to prevent it from damaging parts or paint.

■ Notice on coolant quality

Do not use improper coolant. If improper coolant is used, the engine cooling system may be damaged.

Radiator, condenser and intercooler (if equipped)

Check the radiator, condenser and intercooler and clear away any foreign objects. If any of the above parts is extremely dirty or you are not sure of their condition, have your vehicle inspected by your Toyota dealer.

WARNING

■ When the engine is hot

Do not touch the radiator, condenser or intercooler as they may be hot and cause serious injuries, such as burns.

Battery

Check the battery as follows.

■ Battery exterior

Make sure that the battery terminals are not corroded and that there are no loose connections, cracks, or loose clamps.

- ① Terminals
- ② Hold-down clamp

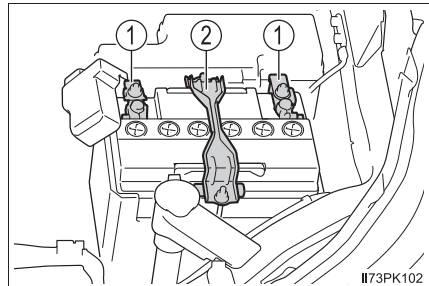

II73PK102

■ Checking battery fluid

Check that the level is between the upper and lower lines.

- ① Upper line
- ② Lower line

If the fluid level is at or below the lower line, add distilled water.

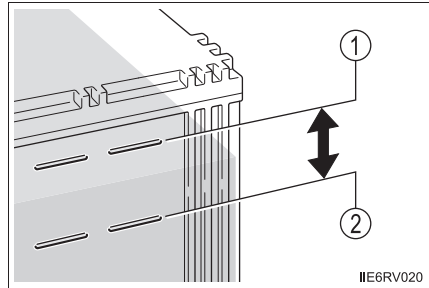

■ Adding distilled water

- 1 Remove the vent plug.
- 2 Add distilled water.

If the upper line cannot be seen, check the fluid level by looking directly at the cell.

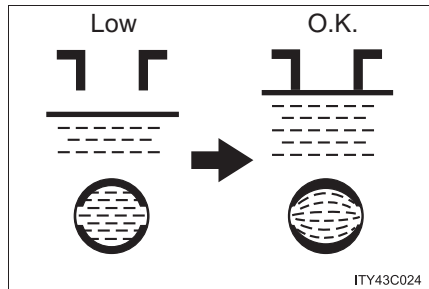

- 3 Put the vent plug back on and close it securely.

■ Before recharging

When recharging, the battery produces hydrogen gas which is flammable and explosive. Therefore, observe the following before recharging:

- If recharging with the battery installed on the vehicle, be sure to disconnect the ground cable.
- Make sure the power switch on the charger is off when connecting and disconnecting the charger cables to the battery.

■ After recharging/reconnecting the battery (vehicles with smart entry & start system)

The engine may not start. Follow the procedure below to initialize the system.

- 1 Shift the shift lever to P (automatic transmission) or depress the brake pedal with the shift lever in N (manual transmission).
 - 2 Open and close any of the doors.
 - 3 Restart the engine.
- Unlocking the doors using the smart entry & start system may not be possible immediately after reconnecting the battery. If this happens, use the wireless remote control or the mechanical key to lock/unlock the doors.
 - Start the engine with the engine switch in ACCESSORY mode. The engine may not start with the engine switch turned off. However, the engine will operate normally from the second attempt.
 - The engine switch mode is recorded by the vehicle. If the battery is reconnected, the vehicle will return the engine switch mode to the status it was in before the battery was disconnected. Make sure to turn off the engine before disconnect the battery. Take extra care when connecting the battery if the engine switch mode prior to discharge is unknown.

If the system will not start even after multiple attempts, contact your Toyota dealer.

■ If a symbol of a battery is shown on the multi-information display

There is a malfunction in the vehicle's charging system.

Immediately stop the vehicle in a safe place and contact your Toyota dealer. Continuing to drive the vehicle may be dangerous.

 **WARNING****■ Chemicals in the battery**

Batteries contain poisonous and corrosive sulfuric acid and may produce hydrogen gas which is flammable and explosive. To reduce the risk of death or serious injury, take the following precautions while working on or near the battery:

- Do not cause sparks by touching the battery terminals with tools.
- Do not smoke or light a match near the battery.
- Avoid contact with eyes, skin and clothes.
- Never inhale or swallow electrolyte.
- Wear protective safety glasses when working near the battery.
- Keep children away from the battery.

■ Where to safely charge the battery

Always charge the battery in an open area. Do not charge the battery in a garage or closed room where there is insufficient ventilation.

■ Emergency measures regarding electrolyte

- If electrolyte gets in your eyes
Flush your eyes with clean water for at least 15 minutes and get immediate medical attention. If possible, continue to apply water with a sponge or cloth while traveling to the nearest medical facility.
- If electrolyte gets on your skin
Wash the affected area thoroughly. If you feel pain or burning, get medical attention immediately.
- If electrolyte gets on your clothes
It can soak through clothing on to your skin. Immediately take off the clothing and follow the procedure above if necessary.
- If you accidentally swallow electrolyte
Drink a large quantity of water or milk. Get emergency medical attention immediately.
- When there is insufficient battery fluid
Do not use if there is insufficient fluid in the battery. There is a possible danger that the battery may explode.

■ When disconnecting the battery

Do not disconnect the negative (-) terminal on the body. The disconnected negative (-) terminal may touch the positive (+) terminal, which may cause a short and result in death or serious injury.

 NOTICE**■ When recharging the battery**

Never recharge the battery while the engine is running. Also, be sure all accessories are turned off.

■ When adding distilled water

Avoid overfilling. Water spilled during battery recharging may cause corrosion.

Washer fluid

If any washer does not work, the washer tank may be empty. Add washer fluid.

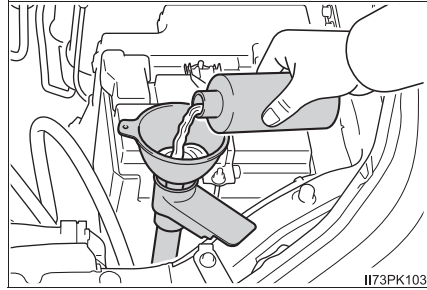
 WARNING**■ When adding washer fluid**

Do not add washer fluid when the engine is hot or running as washer fluid contains alcohol and may catch fire if spilled on the engine etc.

 NOTICE**■ Do not use any fluid other than washer fluid**

Do not use soapy water or engine antifreeze instead of washer fluid. Doing so may cause streaking on the vehicle's painted surfaces as well as damaging the pump leading to problems of the washer fluid not spraying.

■ Diluting washer fluid

Dilute washer fluid with water as necessary. Refer to the freezing temperatures listed on the label of the washer fluid bottle.

Fuel filter (diesel engine only)

You may drain the fuel filter yourself. However, as the operation is difficult, we recommend having it drained by your Toyota dealer. Even if you decide to drain it yourself, contact your Toyota dealer.

The water in the fuel filter needs to be drained if “Water accumulation in fuel filter See owner’s manual” is shown on the multi-information display and a buzzer sounds.

- 1 Vehicles without smart entry & start system: Turn the engine switch to the “LOCK” position.

Vehicles with smart entry & start system: Turn the engine switch off.

- 2 Place a small tray under the drain plug or drain hose to catch the water and any fuel that comes out.

- 3 Perform the draining as shown in the illustration.

- 1 Turn the drain plug counter-clockwise about 2 to 2 1/2 turns.

Loosening more than this will cause water oozing from around the drain plug.

- 2 Operate the priming pump until fuel begins to run out.

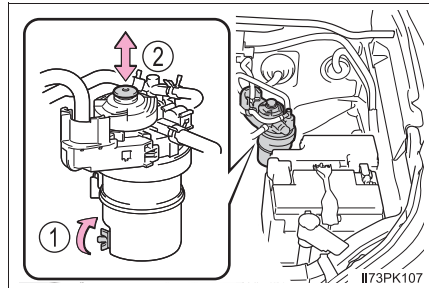

- 4 After draining, tighten the drain plug by hand.

Tires

Replace or rotate tires in accordance with maintenance schedules and treadwear.

Checking tires

Check if the treadwear indicators are showing on the tires. Also check the tires for uneven wear, such as excessive wear on one side of the tread.

Check the spare tire condition and pressure if not rotated.

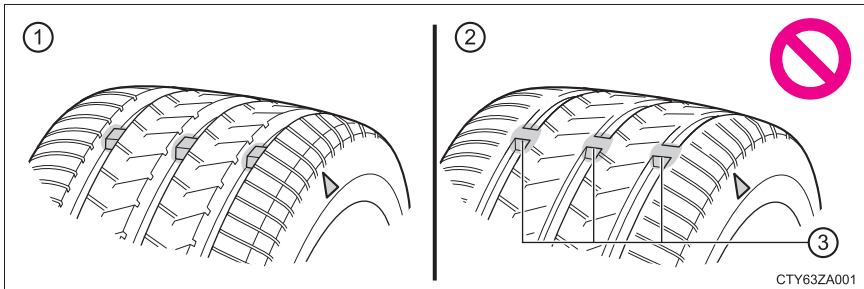

- ① New tread
- ② Worn tread
- ③ Treadwear indicator

The location of treadwear indicators is shown by a "TWI" or "Δ" mark, etc., molded into the sidewall of each tire.

Replace the tires if the treadwear indicators are showing on a tire.

Tire rotation

Rotate the tires in the order shown.

- ▶ Vehicles with spare tire of a different wheel type from the installed tires
- ▶ Vehicles with spare tire of the same wheel type as the installed tires

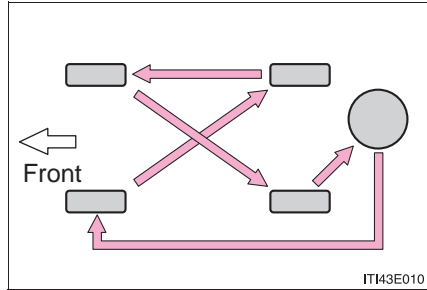
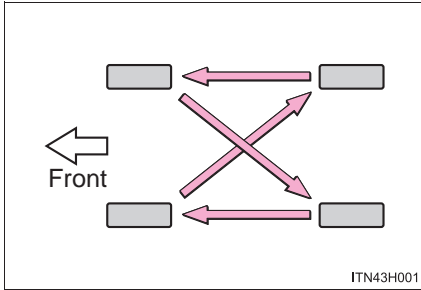

To equalize tire wear and help extend tire life, Toyota recommends that tire rotation is carried out approximately every 10000 km (6000 miles).

■ When to replace your vehicle's tires

Tires should be replaced if:

- The treadwear indicators are showing on a tire.
- You have tire damage such as cuts, splits, cracks deep enough to expose the fabric, and bulges indicating internal damage
- A tire goes flat repeatedly or cannot be properly repaired due to the size or location of a cut or other damage

If you are not sure, consult with your Toyota dealer.

■ Tire life

Any tire over 6 years old must be checked by a qualified technician even if it has seldom or never been used or damage is not obvious.

■ If the tread on snow tires wears down below 4 mm (0.16 in.)

The effectiveness of the tires as snow tires is lost.

 **WARNING****■ When inspecting or replacing tires**

Observe the following precautions to prevent accidents.

Failure to do so may cause damage to parts of the drive train as well as dangerous handling characteristics, which may lead to an accident resulting in death or serious injury.

- Do not mix tires of different makes, models or tread patterns.
Also, do not mix tires of remarkably different treadwear.
- Do not use tire sizes other than those recommended by Toyota.
- Do not mix differently constructed tires (radial, bias-belted or bias-ply tires).
- Do not mix summer, all season and snow tires.
- Do not use tires that have been used on another vehicle.
Do not use tires if you do not know how they were used previously.

 **NOTICE****■ Driving on rough roads**

Take particular care when driving on roads with loose surfaces or potholes. These conditions may cause losses in tire inflation pressure, reducing the cushioning ability of the tires. In addition, driving on rough roads may cause damage to the tires themselves, as well as the vehicle's wheels and body.

■ If tire inflation pressure of each tire becomes low while driving

Do not continue driving, or your tires and/or wheels may be ruined.

Tire inflation pressure

Make sure to maintain proper tire inflation pressure. Tire inflation pressure should be checked at least once per month. However, Toyota recommends that tire inflation pressure be checked once every two weeks. (→P. 478)

■ Effects of incorrect tire inflation pressure

Driving with incorrect tire inflation pressure may result in the following:

- Reduced fuel economy
- Reduced driving comfort and poor handling
- Reduced tire life due to wear
- Reduced safety
- Damage to the drive train

If a tire needs frequent inflating, have it checked by your Toyota dealer.

■ Instructions for checking tire inflation pressure

When checking tire inflation pressure, observe the following:

- Check only when the tires are cold.
If your vehicle has been parked for at least 3 hours or has not been driven for more than 1.5 km or 1 mile, you will get an accurate cold tire inflation pressure reading.
- Always use a tire pressure gauge.
It is difficult to judge if a tire is properly inflated based only on its appearance.
- It is normal for the tire inflation pressure to be higher after driving as heat is generated in the tire. Do not reduce tire inflation pressure after driving.
- Passengers and luggage weight should be placed so that the vehicle is balanced.

 **WARNING****■ Proper inflation is critical to save tire performance**

Keep your tires properly inflated.

If the tires are not properly inflated, the following conditions may occur which could lead to an accident resulting in death or serious injury:

- Excessive wear
- Uneven wear
- Poor handling
- Possibility of blowouts resulting from overheated tires
- Air leaking from between tire and wheel
- Wheel deformation and/or tire damage
- Greater possibility of tire damage while driving (due to road hazards, expansion joints, sharp edges in the road, etc.)

 **NOTICE****■ When inspecting and adjusting tire inflation pressure**

Be sure to put the tire valve caps back on.

If a valve cap is not installed, dirt or moisture may get into the valve and cause an air leak, resulting in decreased tire inflation pressure.

Wheels

If a wheel is bent, cracked or heavily corroded, it should be replaced. Otherwise, the tire may separate from the wheel or cause a loss of handling control.

Wheel selection

When replacing wheels, care should be taken to ensure that they are equivalent to those removed in load capacity, diameter, rim width and inset*.

Replacement wheels are available at your Toyota dealer.

*: Conventionally referred to as “offset”.

Toyota does not recommend using the following:

- Wheels of different sizes or types
- Used wheels
- Bent wheels that have been straightened

Aluminum wheel precautions (if equipped)

- Use only Toyota wheel nuts and wrenches designed for use with your aluminum wheels.
- When rotating, repairing or changing your tires, check that the wheel nuts are still tight after driving 1600 km (1000 miles).
- Be careful not to damage the aluminum wheels when using tire chains.
- Use only Toyota genuine balance weights or equivalent and a plastic or rubber hammer when balancing your wheels.

 **WARNING****■ When replacing wheels**

- Do not use wheels that are a different size from those recommended in the Owner's Manual, as this may result in a loss of handling control.
- Never use an inner tube in a leaking wheel which is designed for a tubeless tire. Doing so may result in an accident, causing death or serious injury.

■ When installing the wheel nuts

- Be sure to install the wheel nuts with the tapered ends facing inward. (→P. 442) Installing the nuts with the tapered ends facing outward can cause the wheel to break and eventually cause the wheel to come off while driving, which could lead to an accident resulting in death or serious injury.
- Never use oil or grease on the wheel bolts or wheel nuts.
Oil and grease may cause the wheel nuts to be excessively tightened, leading to bolt or disc wheel damage. In addition, the oil or grease can cause the wheel nuts to loosen and the wheel may fall off, causing an accident and resulting in death or serious injury. Remove any oil or grease from the wheel bolts or wheel nuts.

■ Use of defective wheels prohibited

Do not use cracked or deformed wheels.

Doing so could cause the tire to leak air during driving, possibly causing an accident.

Air conditioning filter

The air conditioning filter must be changed regularly to maintain air conditioning efficiency.

Removal method

- 1 Vehicles without smart entry & start system: Turn the engine switch to the "LOCK" position.
Vehicles with smart entry & start system: Turn the engine switch off.
- 2 Open the glove box. Turn the claws as shown in the illustration.

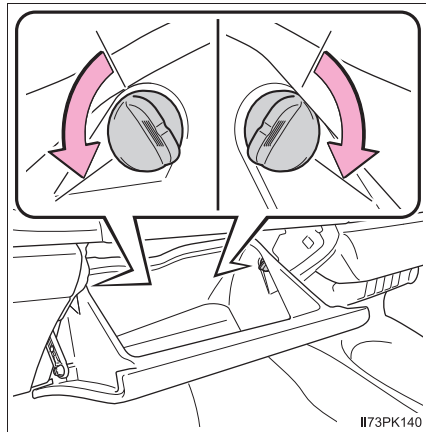

- 3 Pull out the claws.

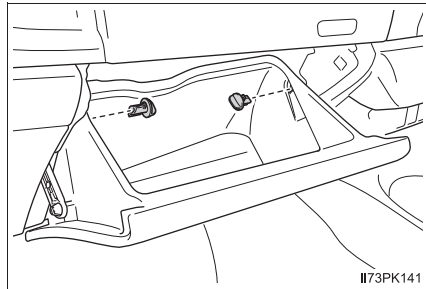

- 4 Pull out the damper (if equipped) as shown in the illustration, and then remove the glove box.

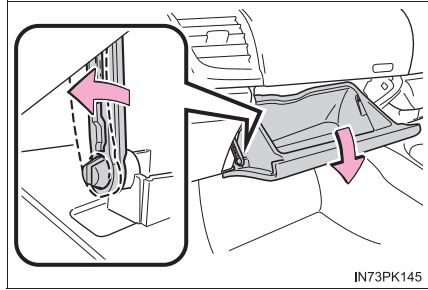

- 5 Remove the filter cover.

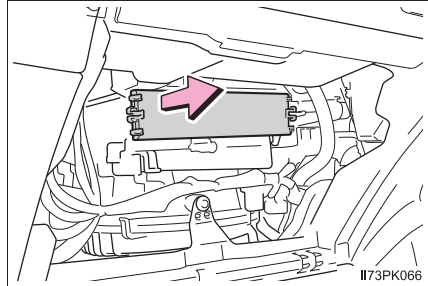

- 6 Remove the air conditioning filter and replace it with a new one.

The “↑UP” marks shown on the filter should be pointing up interval

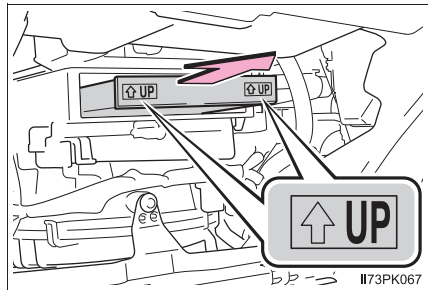

■ Changing interval

Inspect and replace the air conditioning filter according to the maintenance schedule. In dusty areas or areas with heavy traffic flow, early replacement may be required. (For scheduled maintenance information, please refer to the “Warranty and Service Booklet”.)

■ If air flow from the vents decreases dramatically

The filter may be clogged. Check the filter and replace if necessary.



NOTICE

■ When using the air conditioning system

Make sure that a filter is always installed.

Using the air conditioning system without a filter may cause damage to the system.

Wireless remote control/electronic key battery*

Replace the battery with a new one if it is depleted.

You will need the following items:

- Flathead screwdriver
- Small flathead screwdriver
- Lithium battery

Vehicles without smart entry & start system: CR1620

Vehicles with smart entry & start system: CR2032

Replacing the battery

- Vehicles without smart entry & start system

1 Remove the cover.

To prevent damage to the key, cover the tip of the screwdriver with a rag.

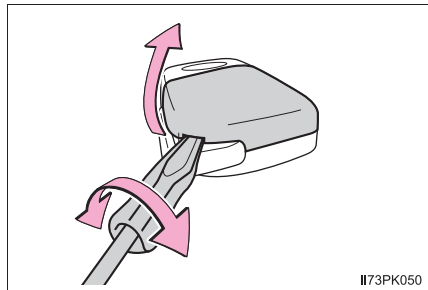

2 Remove the battery cover.

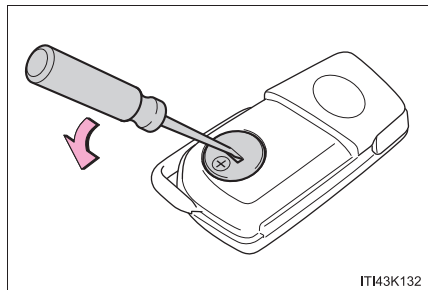

*: If equipped

- 3** Remove the depleted battery.
Insert a new battery with the “+” terminal facing up.

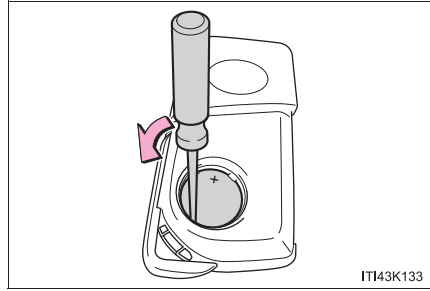

► Vehicles with smart entry & start system

- 1** Take out the mechanical key.

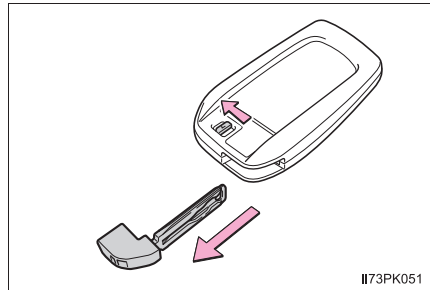

- 2** Remove the cover.

To prevent damage to the key, cover the tip of the screwdriver with a rag.

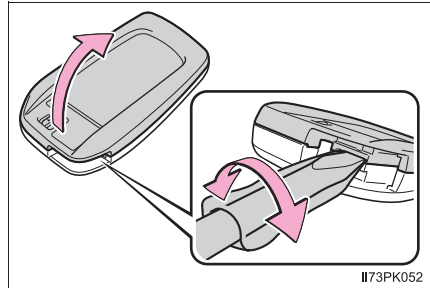

- 3** Remove the depleted battery.
Insert a new battery with the “+” terminal facing up.

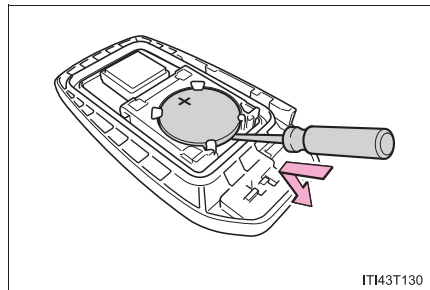

■ Use a lithium battery

Vehicles without smart entry & start system: CR1620

Vehicles with smart entry & start system: CR2032

- Batteries can be purchased at your Toyota dealer, local electrical appliance shops or camera stores.
- Replace only with the same or equivalent type recommended by the manufacturer.
- Dispose of used batteries according to local laws.

■ If the key battery is depleted

The following symptoms may occur:

- The smart entry & start system (if equipped) and wireless remote control will not function properly.
- The operational range will be reduced.

**WARNING****■ Removed battery and other parts**

These parts are small and if swallowed by a child, they can cause choking. Keep away from children. Failure to do so could result in death or serious injury.

**NOTICE****■ For normal operation after replacing the battery**

Observe the following precautions to prevent accidents:

- Always work with dry hands.
Moisture may cause the battery to rust.
- Do not touch or move any other component inside the remote control.
- Do not bend either of the battery terminals.

Checking and replacing fuses

If any of the electrical components do not operate, a fuse may have blown. If this happens, check and replace the fuses as necessary.

- 1 Vehicles without smart entry & start system:
Turn the engine switch to the “LOCK” position.
Vehicles with smart entry & start system:
Turn the engine switch off.

- 2 Open the fuse box cover.

► In the engine compartment

Push the tab in and pull the lock release, and lift the lid off.

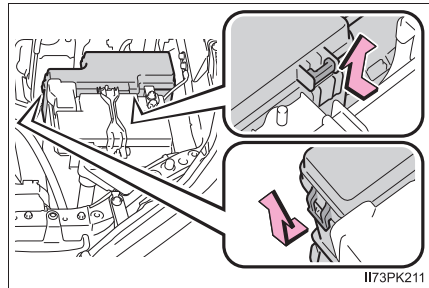

► Under the instrument panel

Remove the cover (if equipped).

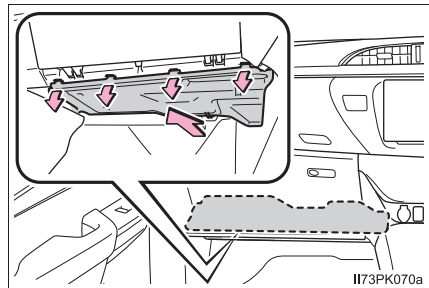

Remove the lid.

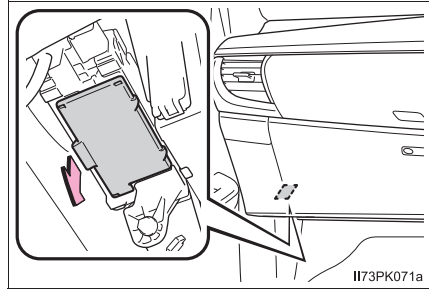

► Behind the instrument panel

Remove the glove box
(→P. 371), and remove the lid.

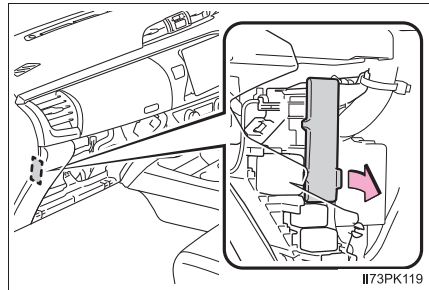

► Behind the cowl side panel

Remove the front passenger's
door scuff plate.

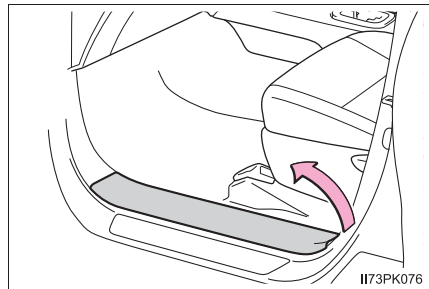

Remove the nut and the cowl side panel.

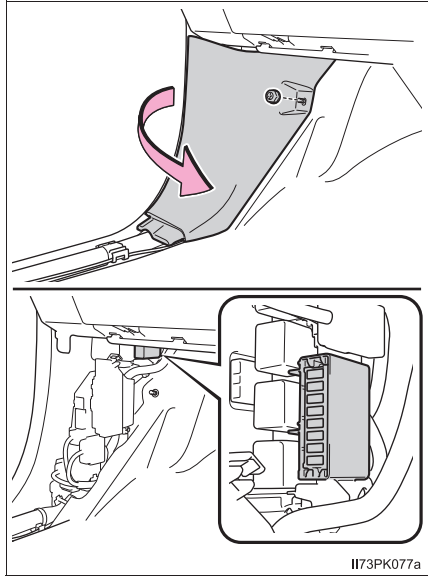

II73PK077a

- 3 Remove the fuse.

Only type A fuse can be removed using the pullout tool.

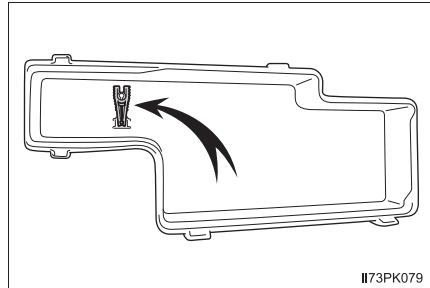

II73PK079

4 Check if the fuse is blown.

- ① Normal fuse
- ② Blown fuse

Type A, B, C and D:

Replace the blown fuse with a new fuse of an appropriate amperage rating. The amperage rating can be found on the fuse box lid.

Type E:

Contact your Toyota dealer.

► Type A

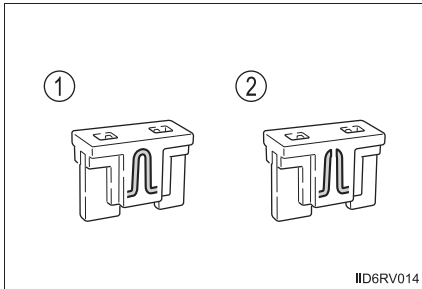

► Type B

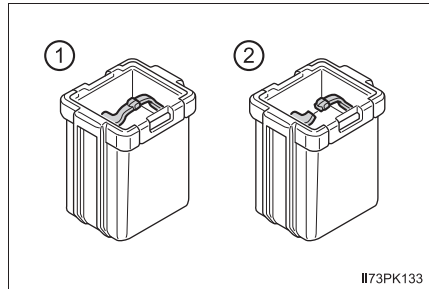

► Type C

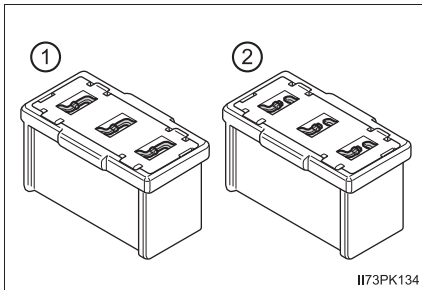

► Type D

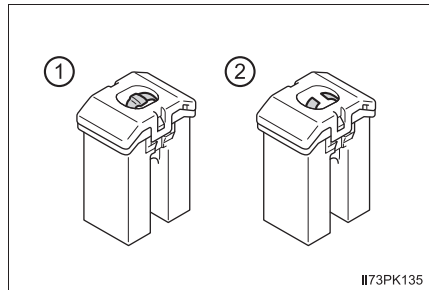

► Type E

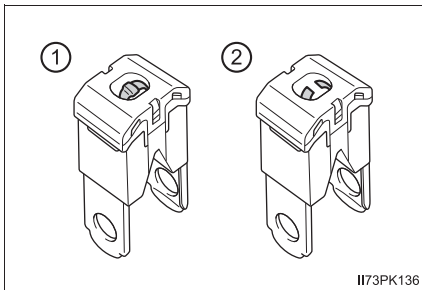

■ After a fuse is replaced

- If the lights do not turn on even after the fuse has been replaced, a bulb may need replacement. (→P. 381)
- If the replaced fuse blows again, have the vehicle inspected by your Toyota dealer.

■ If there is an overload in a circuit

The fuses are designed to blow, protecting the wiring harness from damage.

**WARNING****■ To prevent system breakdowns and vehicle fire**

Observe the following precautions.

Failure to do so may cause damage to the vehicle, and possibly a fire or injury.

- Never use a fuse of a higher amperage rating than that indicated, or use any other object in place of a fuse.
- Always use a genuine Toyota fuse or equivalent.
Never replace a fuse with a wire, even as a temporary fix.
- Do not modify the fuses or fuse boxes.

**NOTICE****■ Before replacing fuses**

Have the cause of electrical overload determined and repaired by your Toyota dealer as soon as possible.

Light bulbs

You may replace the following bulbs by yourself. The difficulty level of replacement varies depending on the bulb. As there is a danger that components may be damaged, we recommend that replacement is carried out by your Toyota dealer.

Preparing for light bulb replacement

Check the wattage of the light bulb to be replaced. (→P. 480)

Bulb locations

The shape of the exterior lights may differ depending on the grade, etc.

■ Front

▶ Halogen headlights type A

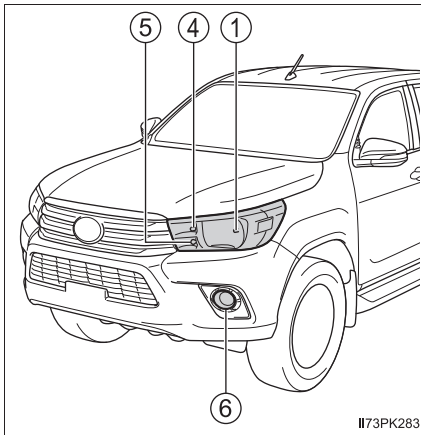

▶ Halogen headlights type B

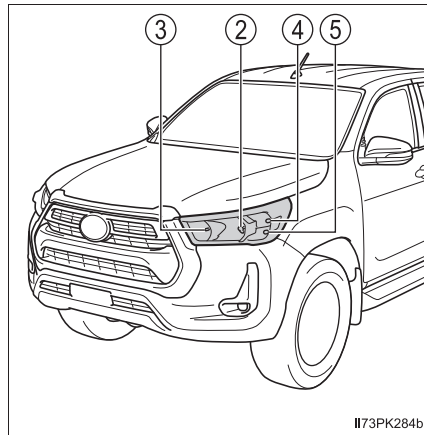

▶ LED headlights

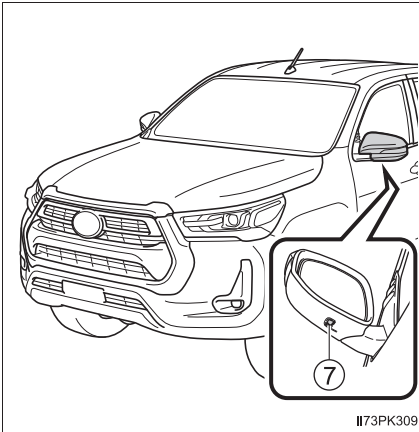

- ① Headlight (high/low beams) (if equipped)
- ② Headlight (low beam) (if equipped)
- ③ Headlight (high beam) (if equipped)
- ④ Front position light/daytime running light (if equipped)
- ⑤ Front turn signal light (if equipped)
- ⑥ Halogen fog light (if equipped)
- ⑦ Outer foot light (if equipped)

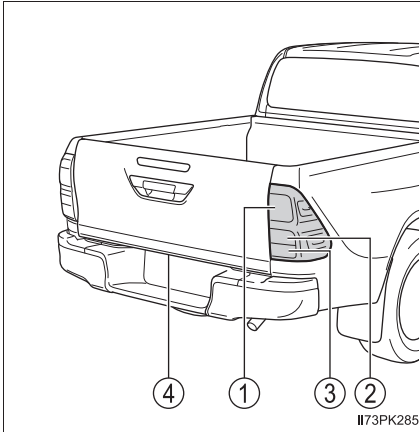
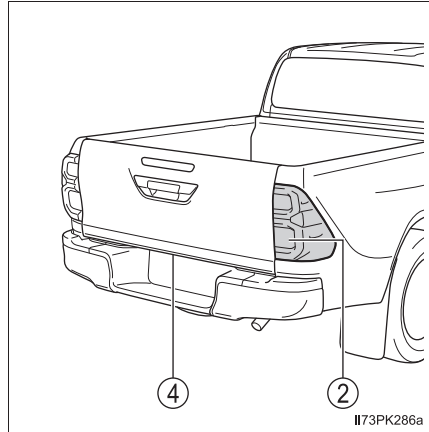
■ Rear**▶ Without LED stop lights****▶ With LED stop lights**

- ① Stop/tail light (if equipped)
- ② Rear turn signal light
- ③ Back-up light (if equipped)
- ④ License plate light

Replacing light bulbs**■ Headlight (high/low beams) (halogen headlights type A)**

- 1 Unplug the connector and remove the rubber cover.

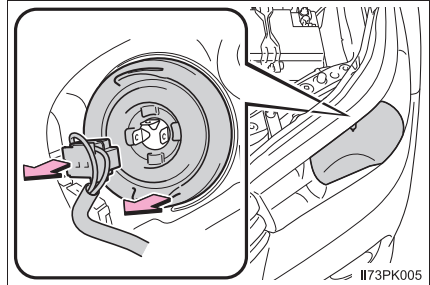

- 2 Release the bulb retaining spring.

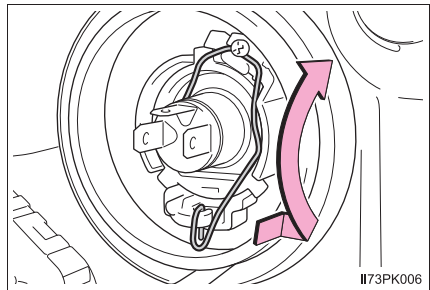

- 3 Remove the bulb.

To install a new bulb, align the tabs of the bulb with the cutouts of the mounting hole.

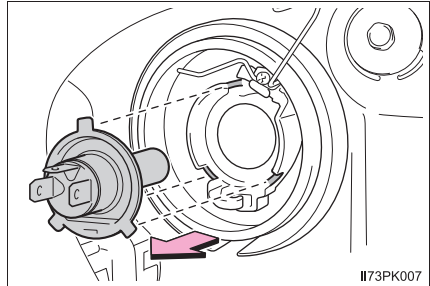

- 4 When installing, reverse the steps listed.

■ Headlight (low beams) (halogen headlights type B)

- 1 Unplug the connector while depressing the lock release.

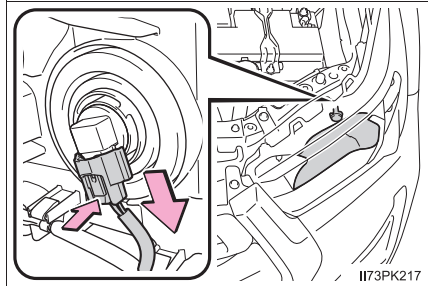

- 2 Turn the bulb base counter-clockwise.

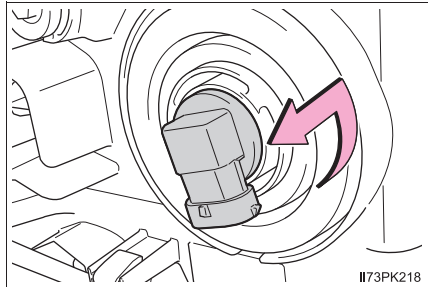

- 3 Replace the light bulb, and install the bulb base.

Align the 3 tabs on the light bulb with the mounting, and insert.

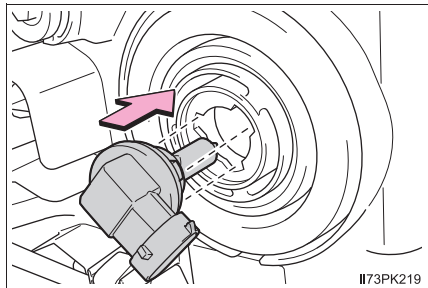

- 4 Turn and secure the bulb base.

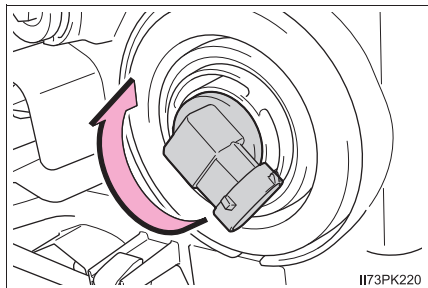

5 Install the connector

Shake the bulb base gently to check that it is not loose, turn the headlight low beams on once and visually confirm that no light is leaking through the mounting.

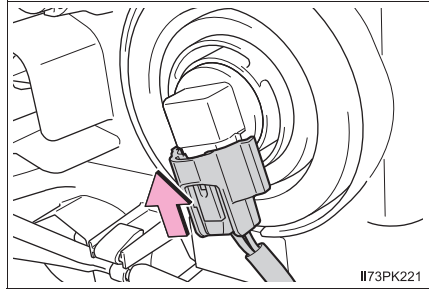

■ Headlight (high beams) (halogen headlights type B)

- 1 Unplug the connector while depressing the lock release.

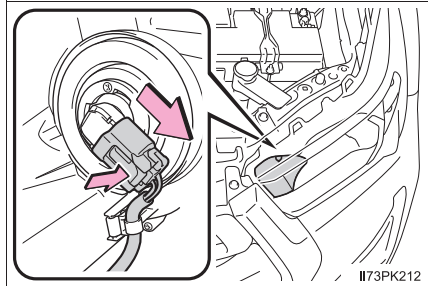

- 2 Turn the bulb base counter-clockwise.

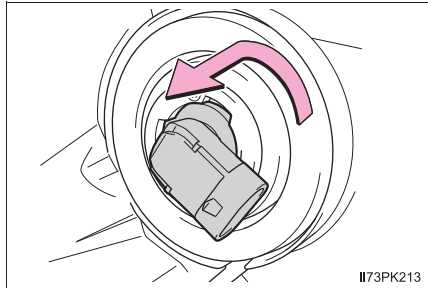

- 3 Replace the light bulb, and install the bulb base.

Align the 3 tabs on the light bulb with the mounting, and insert.

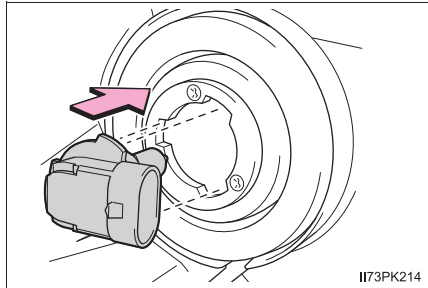

- 4 Turn and secure the bulb base.

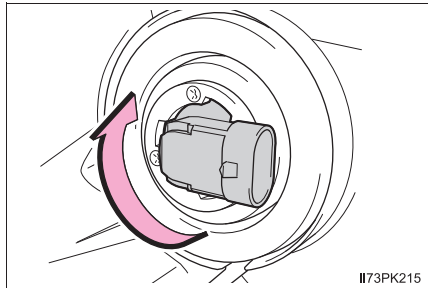

5 Install the connector

Shake the bulb base gently to check that it is not loose, turn the headlight high beams on once and visually confirm that no light is leaking through the mounting.

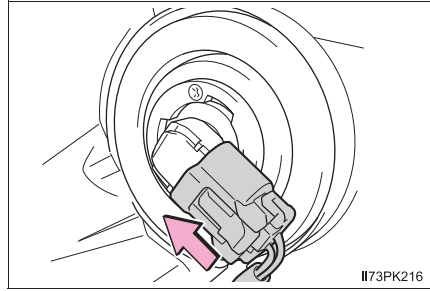

■ Front position lights/daytime running lights (halogen headlights type A)

- 1 Turn the bulb base counter-clockwise.

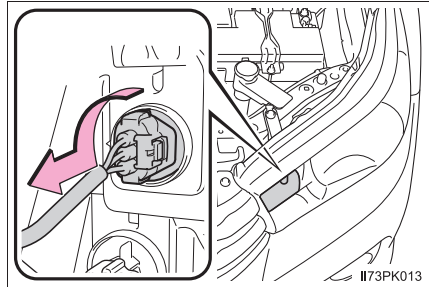

- 2 Remove the light bulb.

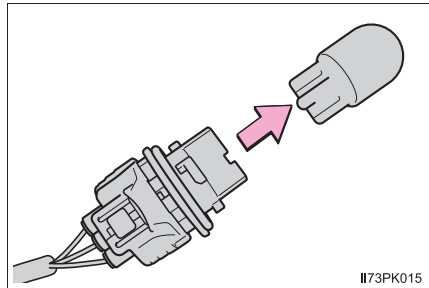

- 3 When installing, reverse the steps listed.

■ Front position lights/daytime running lights (halogen headlight type B)

- 1 To allow enough working space, turn the steering wheel to the opposite side where the bulb to be replaced is located.

Remove the screws and clips.

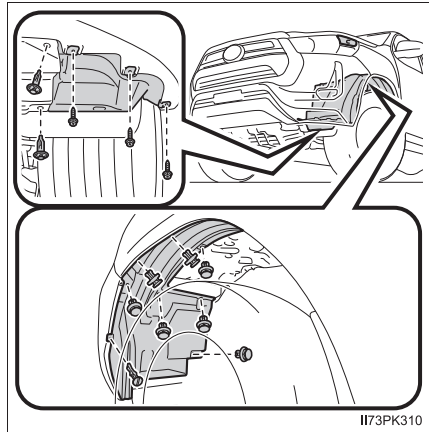

II73PK310

- ① Removing the clip
- ② Installing the clip

► Type A

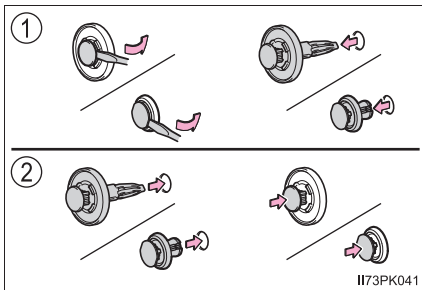

II73PK041

► Type B

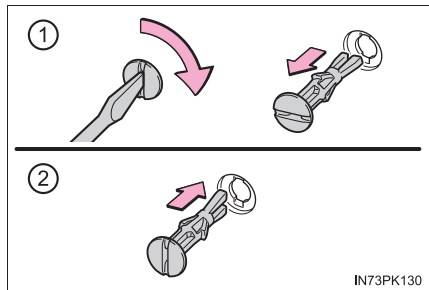

IN73PK130

- 2 Partly remove the fender liner and turn the bulb base counterclockwise.

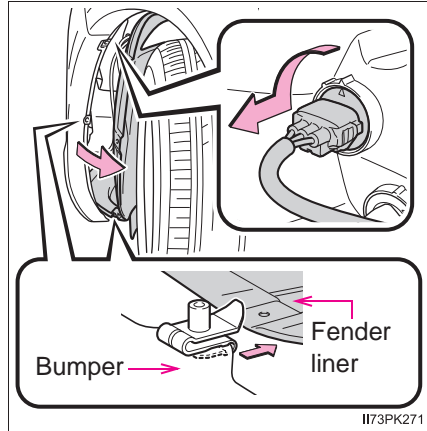

- 3 Remove the light bulb.

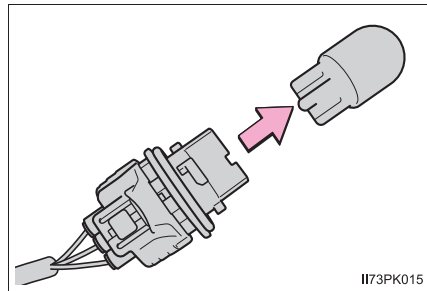

- 4 When installing, reverse the steps listed.

■ Front turn signal lights (halogen headlights type A)

- 1 Turn the bulb base counter-clockwise.

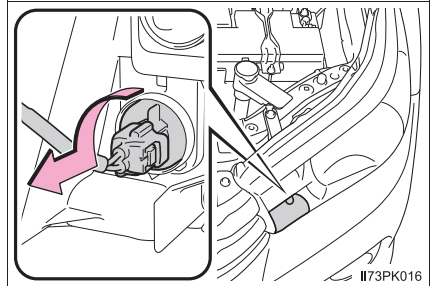

- 2 Remove the light bulb.

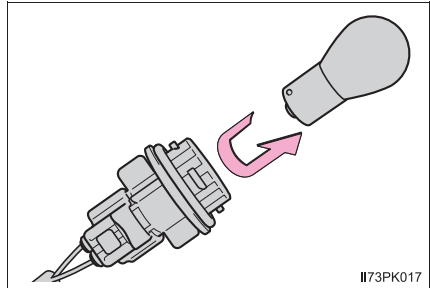

- 3 When installing, reverse the steps listed.

■ Front turn signal lights (halogen headlights type B)

- 1 To allow enough working space, turn the steering wheel to the opposite side where the bulb to be replaced is located.
Remove the screws and clips.

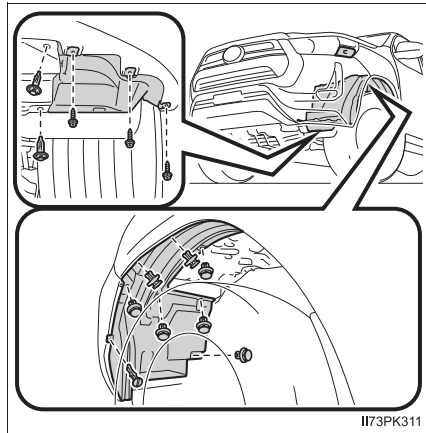

II73PK311

- ① Removing the clip
- ② Installing the clip

► Type A

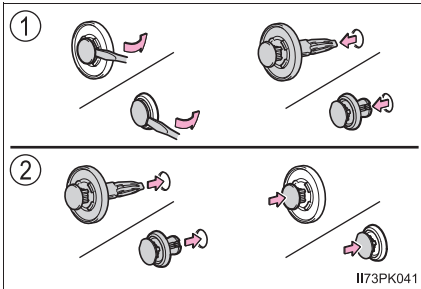

II73PK041

► Type B

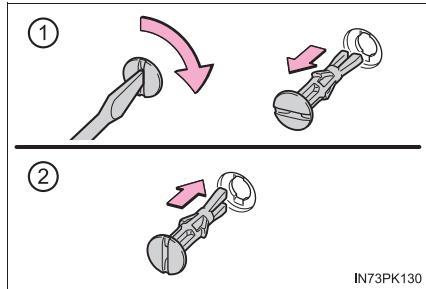

IN73PK130

- 2 Partly remove the fender liner and turn the bulb base counterclockwise.

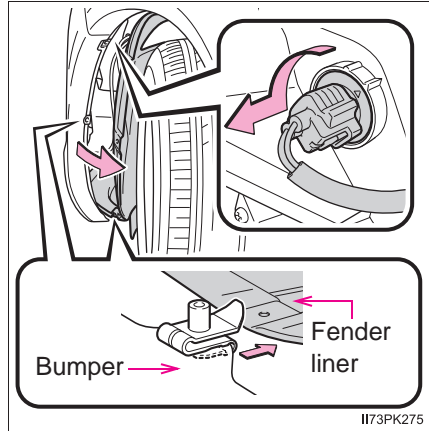

- 3 Remove the light bulb.

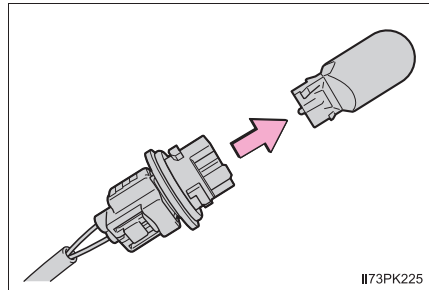

- 4 When installing, reverse the steps listed.

■ Halogen fog lights (if equipped)

- 1 To allow enough working space, turn the steering wheel to the opposite side where the bulb to be replaced is located.

Remove the screws and clips.

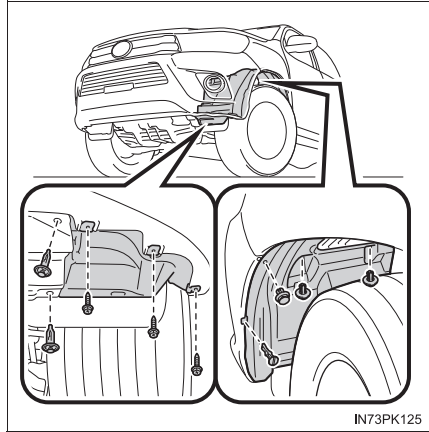

① Removing the clip

② Installing the clip

► Type A

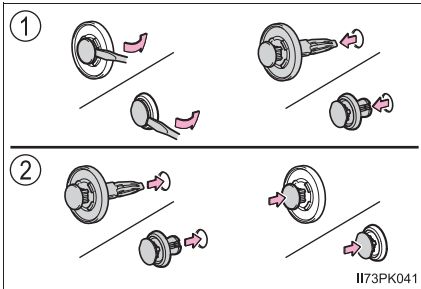

► Type B

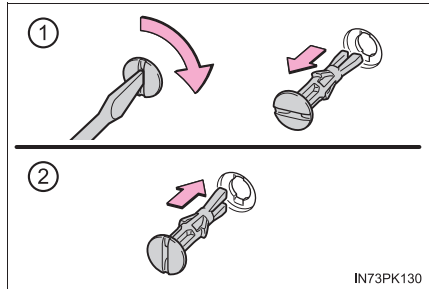

- 2 Partly remove the fender liner and unplug the connector while pressing the lock release.

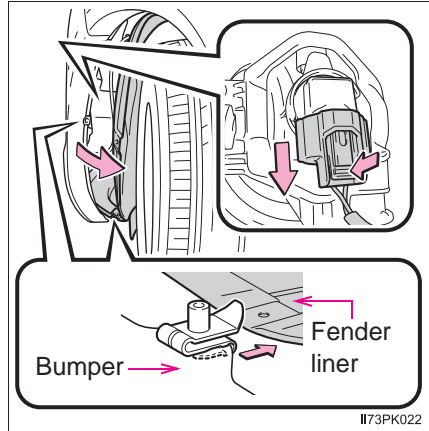

- 3 Turn the bulb base counter-clockwise.

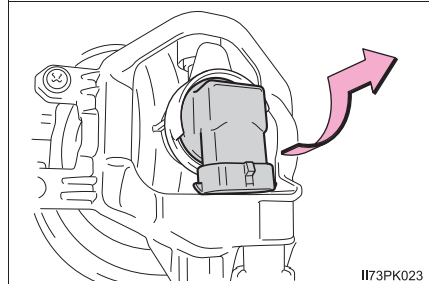

- 4 Replace the light bulb, and install the bulb base.

Align the 3 tabs on the light bulb with the mounting, and insert.

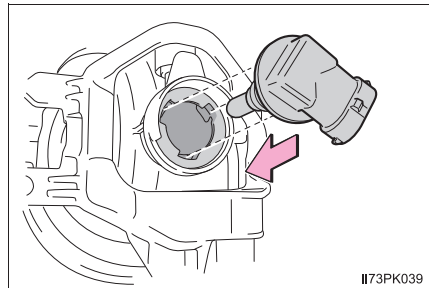

- 5 Turn and secure the bulb base.

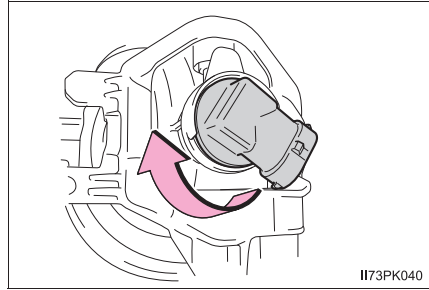

- 6 Install the connector.

Shake the bulb base gently to check that it is not loose, turn the fog lights on once and visually confirm that no light is leaking through the mounting.

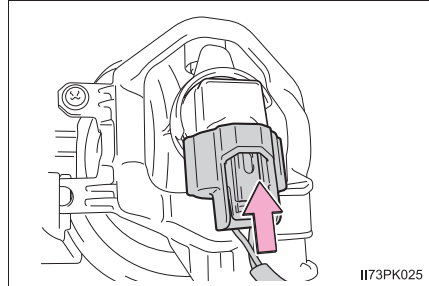

- 7 When installing the fender liner, screws and clips, reverse the removing procedure in steps 1 and 2.

■ Stop/tail lights, rear turn signal lights and back-up lights (without LED stop lights)

- 1 Remove the securing bolts and pull the unit sideways to remove.

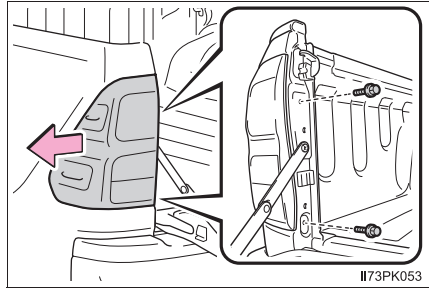

- 2 Turn the bulb base counter-clockwise.

- ① Stop/tail light
- ② Rear turn signal light
- ③ Back-up light

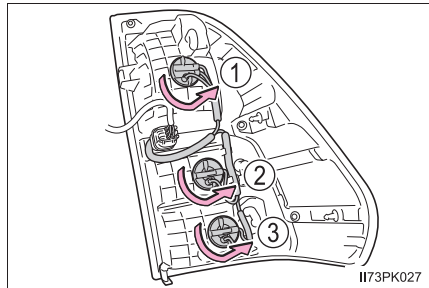

- 3 Remove the light bulb.

- ① Stop/tail light
- ② Rear turn signal light
- ③ Back-up light

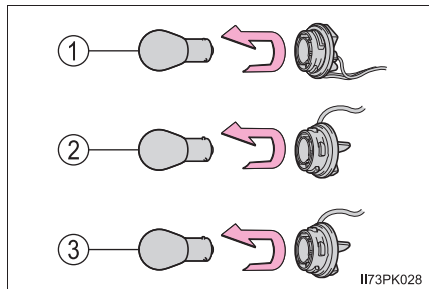

- 4 When installing, reverse the steps listed.

■ Rear turn signal lights (with LED stop lights)

- 1 Remove the securing bolts and pull the unit sideways to remove.

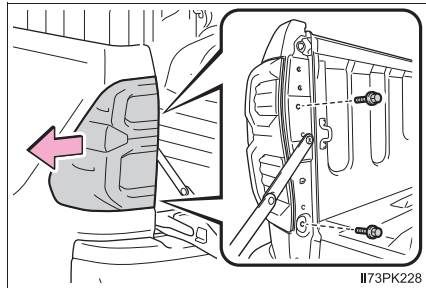

- 2 Turn the bulb base counter-clockwise.

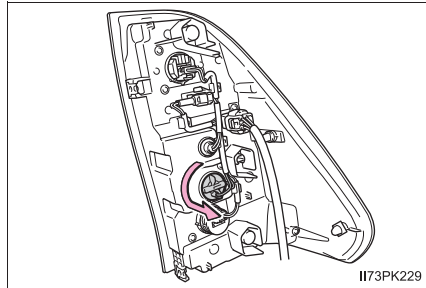

- 3 Remove the light bulb.

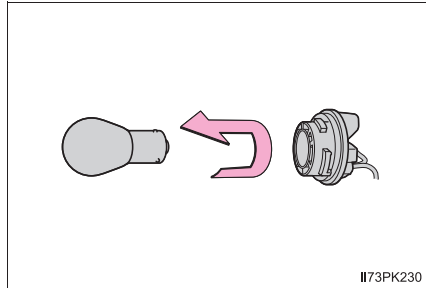

- 4 When installing, reverse the steps listed.

■ License plate light

1 Remove the unit.

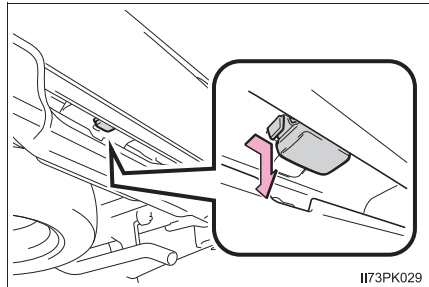

2 Turn the bulb base counter-clockwise.

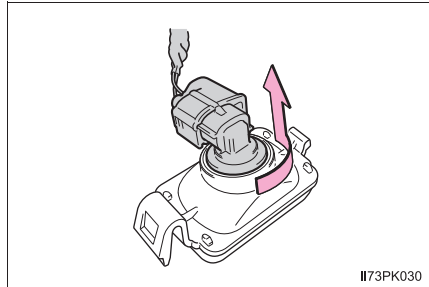

3 Remove the light bulb.

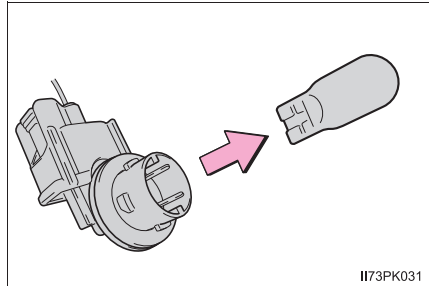

4 When installing, reverse the steps listed.

■ Outer foot lights (if equipped)

- 1 Press the upper part of the outside rear view mirror to tilt the mirror face upward, and apply protective tape to the lower part of the mirror cover.

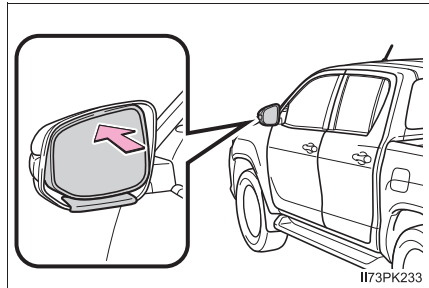

- 2 Insert 2 flathead screwdrivers wrapped in protective tape, and disconnect the tabs behind the mirror.

Pry the mirror out toward you, disconnecting the 2 tabs at a time.

Work carefully, ensuring that you do not drop the mirror.

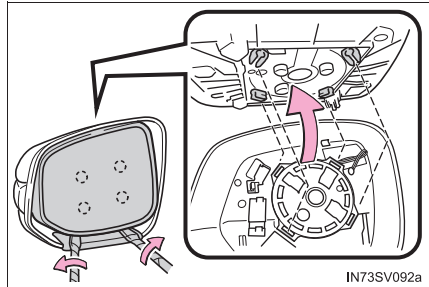

- 3 Disconnect the tab as shown in the illustration.

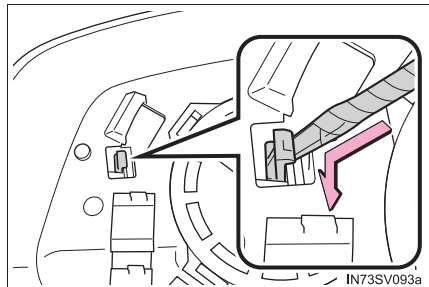

- 4 Remove the upper cover and screws.

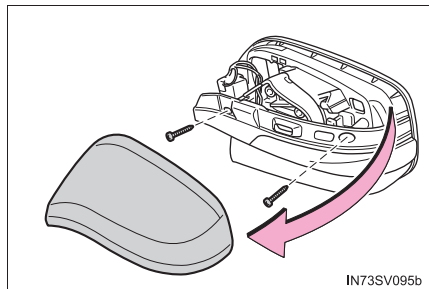

5 Fold the mirror forward.

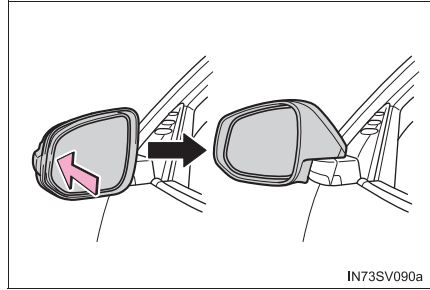

6 Remove the lower cover.

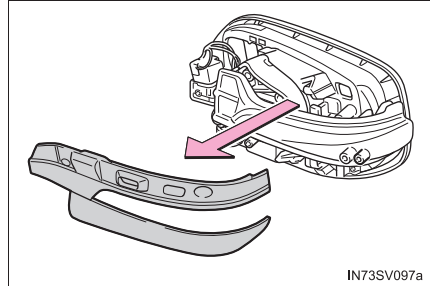

7 Remove the side turn signal light lens.

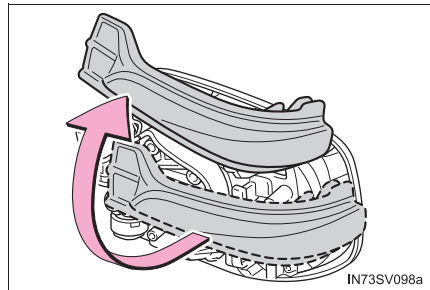

8 Remove the bulb base.

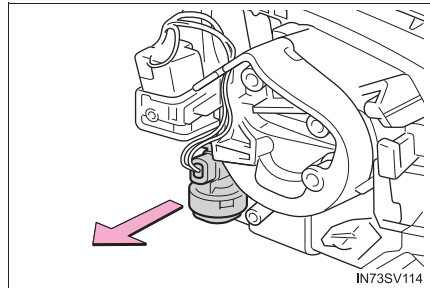

- 9 Turn the cover counterclockwise and remove it.

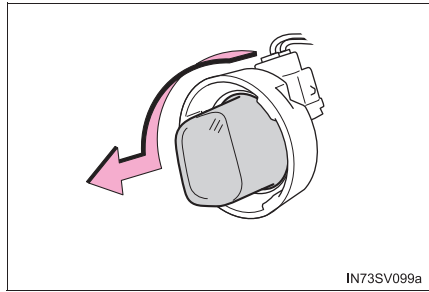

- 10 Remove the light bulb.

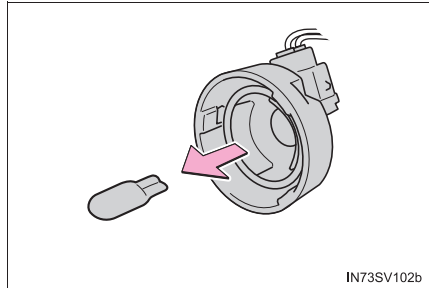

- 11 After installing the new bulb, install the cover clockwise.

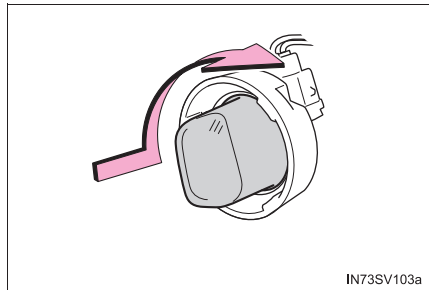

- 12 Install the bulb base.

Insert the two claws (left-hand side) or claw (right-hand side) into the hole(s).

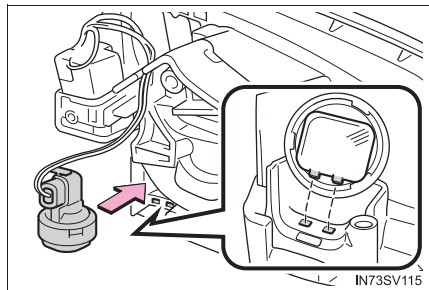

- 13 Install the side turn signal light lens.

Insert the projection into the hole of the lens, and align the lens corner with the plate, as shown in the illustration.

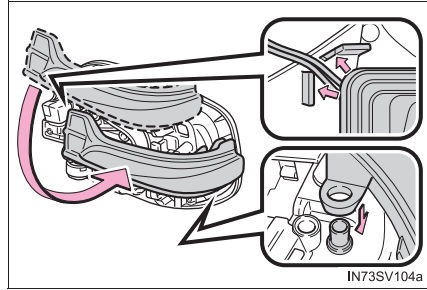

- 14 Install the lower cover.

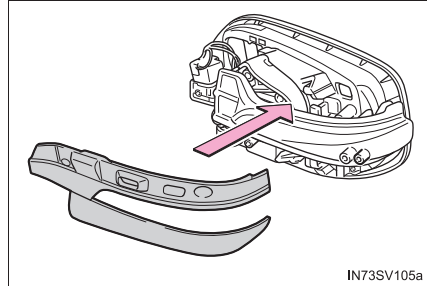

- 15 Return the mirror to its original position.

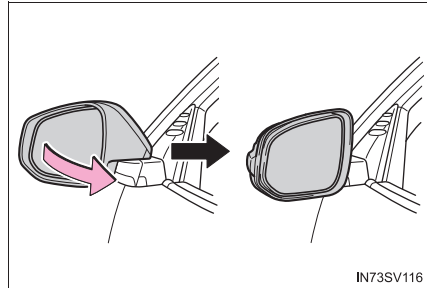

- 16 Install the screws and upper cover.

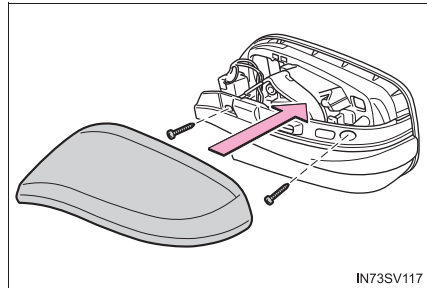

- 17 Align the tabs, and secure the mirror by pushing in each diagonally-opposite pair of tabs in order.

Make sure to insert the tabs in order as shown in the illustration, and push them in until a click is heard.

If you do not hear the click, do not force the tabs in. Instead, remove the mirror and check that the tabs are aligned.

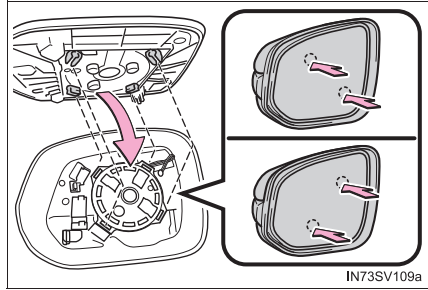

■ Replacing the following bulbs

If any of the lights listed below has burnt out, have it replaced by your Toyota dealer.

- Headlights (high/low beams) (LED headlights)
- Front position lights/daytime running lights (LED headlights)
- Front turn signal lights (LED headlights)
- Side turn signal lights
- LED fog lights (if equipped)
- LED stop lights
- Tail lights (LED stop lights)
- Back-up lights (LED stop lights)
- High mounted stoplight (if equipped)

■ When installing the rubber cover of the headlight (halogen headlights type A)

Ensure the rubber cover is securely attached.

- ① Fit the rubber cover outer circumference in firmly.
- ② Fit the rubber cover around the light bulb in until the light bulb plug can be seen.

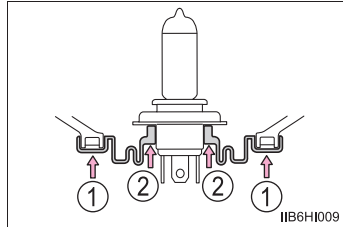

■ LED lights

The following lights consist of a number of LEDs. If any of the LEDs burn out, take your vehicle to your Toyota dealer to have the light replaced.

- Headlights (high/low beams) (LED headlights)
- Front position lights/daytime running lights (LED headlights)
- Front turn signal lights (LED headlights)
- Side turn signal lights (mirror-mounted type)
- LED fog lights (if equipped)
- LED stop lights
- Tail lights (LED stop lights)
- Back-up lights (LED stop lights)
- High mounted stoplight (if equipped)

■ Condensation build-up on the inside of the lens

Temporary condensation build-up on the inside of the headlight lens does not indicate a malfunction. Contact your Toyota dealer for more information in the following situations:

- Large drops of water have built up on the inside of the lens.
- Water has built up inside the headlight.

 **WARNING****■ Replacing light bulbs**

- Turn off the lights. Do not attempt to replace the bulb immediately after turning off the lights.

The bulbs become very hot and may cause burns.

- Do not touch the glass portion of the light bulb with bare hands. When it is unavoidable to hold the glass portion, use and hold with a clean dry cloth to avoid getting moisture and oils on the bulb.

Also, if the bulb is scratched or dropped, it may blow out or crack.

- Fully install light bulbs and any parts used to secure them. Failure to do so may result in heat damage, fire, or water entering the headlight unit. This may damage the headlights or cause condensation to build up on the lens.

- Do not attempt to repair or disassemble light bulbs, connectors, electric circuits or component parts.

Doing so may result in death or serious injury due to electric shock.

■ To prevent damage or fire

- Make sure bulbs are fully seated and locked.
- Check the wattage of the bulb before installing to prevent heat damage.

 **NOTICE****■ When replacing the outer foot lights**

If the front window is stopping you from conducting the replace operation properly, open the window on the side you are working on to allow you enough space to work. Continuing the operation without giving yourself enough space to work could lead you to scratch the vehicle.

When trouble arises

7

7-1. Essential information

Emergency flashers	410
If your vehicle has to be stopped in an emergency.....	411

7-2. Steps to take in an emergency

If your vehicle needs to be towed	413
If you think something is wrong.....	419
Fuel pump shut off system (gasoline engine only).....	420
If a warning light turns on or a warning buzzer sounds	421
If a warning message is displayed	426
If you have a flat tire	431
If the engine will not start.....	448
If the electronic key does not operate properly (vehicles with smart entry & start system).....	450
If the vehicle battery is discharged	454
If your vehicle overheats....	459
If you run out of fuel and the engine stalls (diesel engine only)	462
If the vehicle becomes stuck	463

Emergency flashers

The emergency flashers are used to warn other drivers when the vehicle has to be stopped in the road due to a breakdown, etc.

Press the switch.

All the turn signal lights will flash.
To turn them off, press the switch once again.

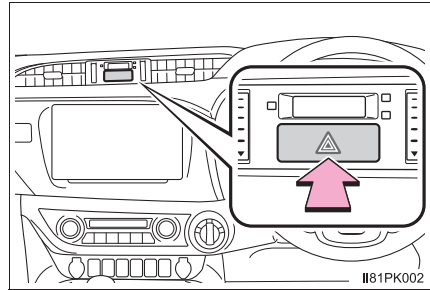

■ Emergency flashers

If the emergency flashers are used for a long time while the engine is not operating, the battery may discharge.

If your vehicle has to be stopped in an emergency

Only in an emergency, such as if it becomes impossible to stop the vehicle in the normal way, stop the vehicle using the following procedure:

- 1 Steadily step on the brake pedal with both feet and firmly depress it.
Do not pump the brake pedal repeatedly as this will increase the effort required to slow the vehicle.
- 2 Shift the shift lever to N.
 - ▶ If the shift lever is shifted to N
- 3 After slowing down, stop the vehicle in a safe place by the road.
- 4 Stop the engine.
 - ▶ If the shift lever cannot be shifted to N
- 3 Keep depressing the brake pedal with both feet to reduce vehicle speed as much as possible.
- 4 Vehicles without smart entry & start system:
Stop the engine by turning the engine switch to the “ACC” position.

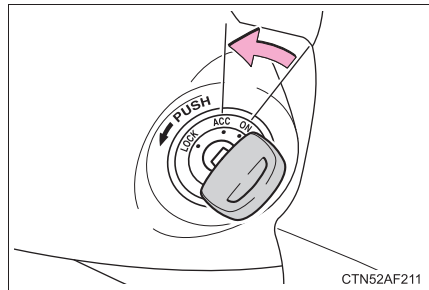

Vehicles with smart entry & start system:

To stop the engine, press and hold the engine switch for 2 consecutive seconds or more, or press it briefly 3 times or more in succession.

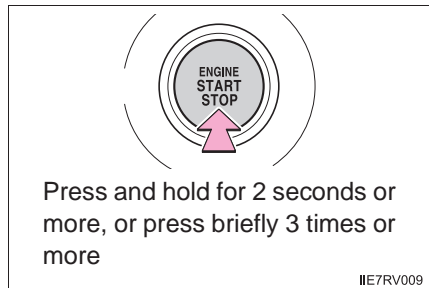

- 5 Stop the vehicle in a safe place by the road.

**WARNING****■ If the engine has to be turned off while driving**

- Power assist for the brakes and steering wheel will be lost, making the brake pedal harder to depress and the steering wheel heavier to turn. Decelerate as much as possible before turning off the engine.
- Vehicles without smart entry & start system: Never attempt to remove the key, as doing so will lock the steering wheel.

If your vehicle needs to be towed

If towing is necessary, we recommend having your vehicle towed by your Toyota dealer or commercial towing service, using a wheel-lift type truck or flatbed truck.

Use a safety chain system for all towing, and abide by all state/provincial and local laws.

Situations when it is necessary to contact dealers before towing

The following may indicate a problem with your transmission. Contact your Toyota dealer or commercial towing service before towing.

- The engine is running but the vehicle does not move.
- The vehicle makes an abnormal sound.

Towing with a sling-type truck

Do not tow with a sling-type truck to prevent body damage.

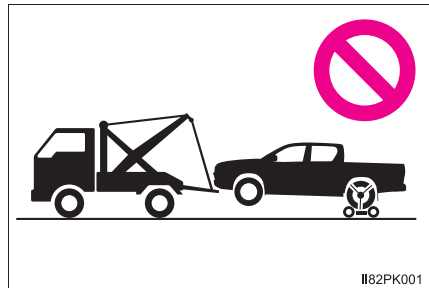

Towing with a wheel-lift type truck

▶ From the front

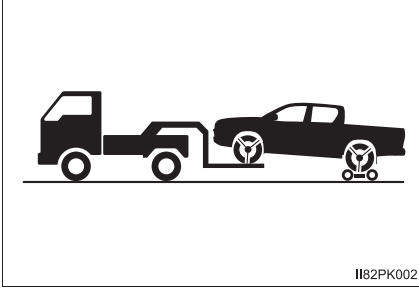

Use a towing dolly under the rear wheels.

▶ From the rear

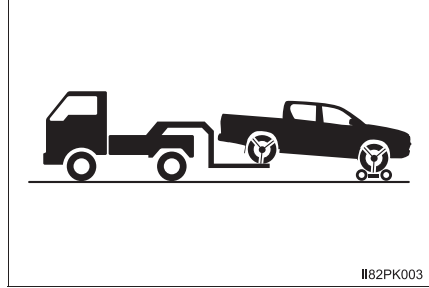

Use a towing dolly under the front wheels.

Using a flatbed truck

If your vehicle is transported by a flatbed truck, it should be tied down at the locations shown in the illustrations.

► 2WD models

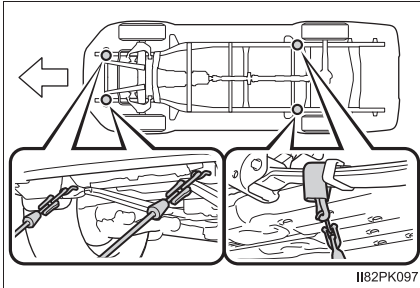

► 4WD models and Pre Runner

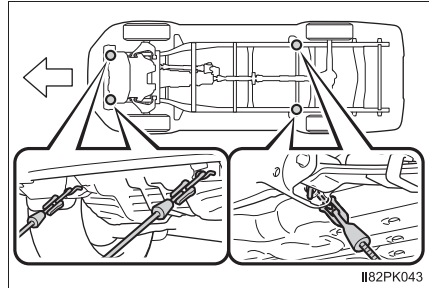

When attaching the hooks to the rear of the vehicle, make sure to attach them to the inside of the vehicle.

If you use chains or cables to tie down your vehicle, the angles shaded in black must be 45°.

Do not overly tighten the tie downs or the vehicle may be damaged.

If you cannot tie down the vehicle using the method above, use tire strapping belts.

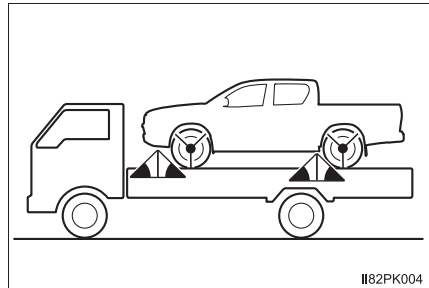

Emergency towing

If a tow truck is not available in an emergency, your vehicle may be temporarily towed using cables or chains secured to the emergency towing hooks. This should only be attempted on hard surfaced roads for at most 80 km (50 miles) at under 30 km/h (18 mph).

A driver must be in the vehicle to steer and operate the brakes. The vehicle's wheels, drive train, axles, steering and brakes must be in good condition.

Emergency towing procedure

- 1 Securely attach cables or chains to the towing hooks.

Take care not to damage the vehicle body.

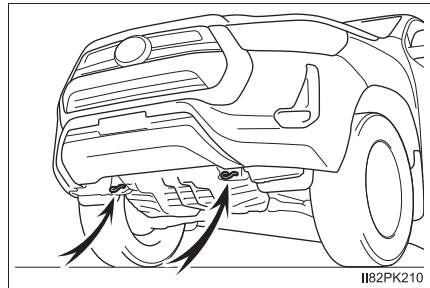

- 2 Enter the vehicle being towed and start the engine.

If the engine does not start, turn the engine switch to the "ON" position (vehicles without smart entry & start system) or IGNITION ON mode (vehicles with smart entry & start system).

- 3 4WD models: Turn the front-wheel drive control switch to H2.
(→P. 270)
- 4 Shift the shift lever to N and release the parking brake.

When the shift lever cannot be shifted (automatic transmission):
→P. 189

■ While towing

If the engine is not running, the power assist for the brakes and steering will not function, making steering and braking more difficult.

⚠ WARNING

Observe the following precautions.
Failure to do so may result in death or serious injury.

■ When towing the vehicle

2WD models and Pre Runner: Be sure to transport the vehicle with all four wheels raised off the ground. If the vehicle is towed with the tires contacting the ground, the drivetrain and related parts may be damaged or an accident may occur due to a change in direction of the vehicle.

4WD models: Be sure to transport the vehicle with all four wheels raised off the ground. If the vehicle is towed with the tires contacting the ground, the drivetrain and related parts may be damaged, and the vehicle may fly off the truck.

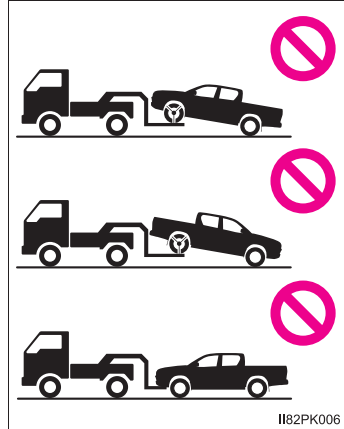

■ While towing

- When towing using cables or chains, avoid sudden starts, etc. which place excessive stress on the towing hooks, cables or chains. The towing hooks, cables or chains may become damaged, broken debris may hit people, and cause serious damage.
- Do not turn the engine switch to the “LOCK” position (vehicles without smart entry & start system) or off (vehicles with smart entry & start system).
There is a possibility that the steering wheel is locked and cannot be operated.

**NOTICE**

- **To prevent damage to the vehicle when towing using a wheel-lift type truck**
 - Do not tow the vehicle from the rear when the engine switch is in the “LOCK” position or the key is removed (vehicles without smart entry & start system) or the engine switch is turned to off (vehicles with smart entry & start system). The steering lock mechanism is not strong enough to hold the front wheels straight.
 - When raising the vehicle, ensure adequate ground clearance for towing at the opposite end of the raised vehicle. Without adequate clearance, the vehicle could be damaged while being towed.
- **To prevent damage to the vehicle when towing with a sling-type truck**

Do not tow with a sling-type truck, either from the front or rear.
- **To prevent damage to the vehicle during emergency towing**

Do not secure cables or chains to the suspension components.

If you think something is wrong

If you notice any of the following symptoms, your vehicle probably needs adjustment or repair. Contact your Toyota dealer as soon as possible.

Visible symptoms

- Fluid leaks under the vehicle.
(Water dripping from the air conditioning after use is normal.)
- Flat-looking tires or uneven tire wear
- Engine coolant temperature gauge needle continually points higher than normal.

Audible symptoms

- Changes in exhaust sound
- Excessive tire squeal when cornering
- Strange noises related to the suspension system
- Pinging or other noises related to the engine

Operational symptoms

- Engine missing, stumbling or running roughly
- Appreciable loss of power
- Vehicle pulls heavily to one side when braking
- Vehicle pulls heavily to one side when driving on a level road
- Loss of brake effectiveness, spongy feeling, pedal almost touches the floor

Fuel pump shut off system (gasoline engine only)

To minimize the risk of fuel leakage when the engine stalls or when an airbag inflates upon collision, the fuel pump shut off system stops the supply of fuel to the engine.

Follow the procedure below to restart the engine after the system is activated.

- 1 Turn the engine switch to the “ACC” or “LOCK” position (vehicles without smart entry & start system) or ACCESSORY mode or off (vehicles with smart entry & start system).
- 2 Restart the engine.



NOTICE

■ Before starting the engine



Inspect the ground under the vehicle.





If you find that fuel has leaked onto the ground, the fuel system has been damaged and is in need of repair. Do not restart the engine.







If a warning light turns on or a warning buzzer sounds



Calmly perform the following actions if any of the warning lights comes on or flashes. If a light comes on or flashes, but then goes off, this does not necessarily indicate a malfunction in the system. However, if this continues to occur, have the vehicle inspected by your Toyota dealer.

Warning light and warning buzzer list

Warning light	Warning light/Details/Actions
	<p>Brake system warning light (warning buzzer) Indicates:</p> <ul style="list-style-type: none"> • Low brake fluid • Malfunction in the brake system • Low negative pressure in the vacuum tank (diesel engine) <p>→ Immediately stop the vehicle in a safe place and contact your Toyota dealer. Continuing to drive the vehicle may be dangerous.</p>
 <p>(Flashes or illuminates)</p>	<p>Malfunction indicator lamp (warning buzzer) Indicates the followings if the warning light comes on or flashes:</p> <ul style="list-style-type: none"> • Malfunction in the electronic engine control system. • Malfunction in the electronic throttle control system. • Malfunction in the electronic automatic transmission control system. (if equipped) • The boost pressure in the turbocharger is abnormally high.*¹ (diesel engine) • Malfunction in the DPF system (if equipped) <p>→ Have the vehicle inspected by your Toyota dealer immediately.</p>
	<p>SRS warning light Indicates a malfunction in:</p> <ul style="list-style-type: none"> • The SRS airbag system; • The seat belt pretensioner system; or • The front passenger occupant classification system <p>→ Have the vehicle inspected by your Toyota dealer immediately.</p>

Warning light	Warning light/Details/Actions
	<p>ABS warning light Indicates a malfunction in:</p> <ul style="list-style-type: none"> • The ABS; or • The brake assist system <p>→ Have the vehicle inspected by your Toyota dealer immediately.</p>
	<p>Power steering system warning light (warning buzzer) (if equipped) Indicates a malfunction in the power steering system</p> <p>→ Have the vehicle inspected by your Toyota dealer immediately.</p>
	<p>Slip indicator Indicates a malfunction in:</p> <ul style="list-style-type: none"> • The VSC system; • Trailer sway control system; • The TRC/A-TRC system; • The AUTO LSD system (if equipped); • The hill-start assist control system; or • The downhill assist control system (if equipped) <p>→ Have the vehicle inspected by your Toyota dealer immediately. The light will flash when any of the above systems other than the hill-start assist control system are operating.</p>
 <p>(Flashes)</p>	<p>Low speed four-wheel drive indicator light (if equipped) Indicates a malfunction in the four-wheel drive system when the light flashes rapidly.</p> <p>→ Have the vehicle inspected by your Toyota dealer immediately.</p>
 <p>(Flashes)</p>	<p>Rear differential lock indicator light (if equipped) Indicates a malfunction in the rear differential lock system when the light flashes rapidly.</p> <p>→ Have the vehicle inspected by your Toyota dealer immediately.</p>

Warning light	Warning light/Details/Actions
 <p>(Flashes or illuminates)</p>	<p>PCS warning light When a buzzer sounds simultaneously: Indicates a malfunction has occurred in the PCS (Pre-Collision System). → Have the vehicle inspected by your Toyota dealer immediately. When a buzzer does not sound: The PCS (Pre-Collision System) has become temporarily unavailable, corrective action may be necessary. → Follow the instructions displayed on the multi-information display. (→P. 218, 426) If the PCS (Pre-Collision System) or VSC (Vehicle Stability Control) system is disabled, the PCS warning light will illuminate. → P. 230</p>
 <p>(Yellow)</p>	<p>LDA indicator (warning buzzer) Indicates a malfunction in the LDA (Lane Departure Alert with Yaw Assist Function) → Follow the instructions displayed on the multi-information display. (→P. 241)</p>
 <p>(Flashes or illuminates)</p>	<p>Driver's and front passenger's seat belt reminder light (warning buzzer)*2 Warns the driver and front passenger to fasten his/her seat belt → Fasten the seat belt.</p>
 <p>(Flashes or illuminates) OR  (Flashes or illuminates)</p>	<p>Rear passengers' seat belt reminder lights (warning buzzer)*3 (if equipped) Warn the rear passengers to fasten their seat belts → Fasten the seat belt.</p>
	<p>Low fuel level warning light Indicates remaining fuel is approximately 12.0 L (3.2 gal., 2.6 Imp.gal.) or less → Refuel the vehicle.</p>
 <p>(Flashes or illuminates)</p>	<p>Master warning light (warning buzzer) (if equipped) A buzzer sounds and the warning light comes on and flashes to indicate that the master warning system has detected a malfunction. → P. 426</p>

Warning light	Warning light/Details/Actions
	Parking brake indicator light (warning buzzer)*4 Warns the driver to release parking brake. → Release the parking brake.
	AUTO LSD indicator (if equipped) Indicate that the system is temporarily unavailable, due to the brake system overheats. → P. 295

- *1: Slow down until the lamp goes off.
- *2: The driver's and front passenger's seat belt warning buzzer sounds to alert the driver and front passenger that his or her seat belt is not fastened. If the seat belt is unfastened, the buzzer sounds intermittently for a certain period of time after the vehicle reaches a certain speed.
- *3: The rear passengers' seat belt warning buzzer sounds to alert the rear passenger that his or her seat belt is not fastened. If the seat belt is unfastened, the buzzer sounds intermittently for a certain period of time after the vehicle reaches a certain speed.
- *4: The parking brake engaged warning buzzer sounds if the vehicle reaches a speed of approximately 5 km/h (3 mph) or more.

■ Passenger detection sensor, seat belt reminder and warning buzzer

- If luggage is placed on the passenger seat, the front passenger detection sensor or the rear passenger detection sensor may cause the warning light to flash and the warning buzzer to sound even if a passenger is not sitting in the seat.
- If a cushion is placed on the seat, the sensor may not detect a passenger, and the warning light may not operate properly.

■ If the malfunction indicator lamp comes on while driving

The malfunction indicator lamp will come on if the fuel tank becomes completely empty. If the fuel tank is empty, refuel the vehicle immediately. The malfunction indicator lamp will go off after several trips.

If the malfunction indicator lamp does not go off, contact your Toyota dealer as soon as possible.

■ Warning buzzer

In some cases, the buzzer may not be heard due to being in a noisy location or audio sound.

 WARNING

■ **If a warning light comes on or a warning buzzer sounds when a warning message is shown on the multi-information display**

Check and follow the message shown on the multi-information display. Failure to do so may result in death or serious injury.

■ **If both the ABS and the brake system warning lights remain on**

Stop your vehicle in a safe place immediately and contact your Toyota dealer. The vehicle will become extremely unstable during braking, and the ABS system may fail, which could cause an accident resulting in death or serious injury.

 NOTICE

■ **If the malfunction indicator lamp comes on when the boost pressure in the turbocharger is abnormally high (diesel engine)**

Never drive at high speed or race the engine even after the lamp goes off.

If a warning message is displayed

The multi-information display shows warnings of system malfunctions, incorrectly performed operations, and messages that indicate a need for maintenance. When a message is shown, perform the correction procedure appropriate to the message.

① Master warning light

The master warning light also comes on or flashes in order to indicate that a message is currently being displayed on the multi-information display.

② Multi-information display

③ Handling method

Follow the instructions of the message on the multi-information display.

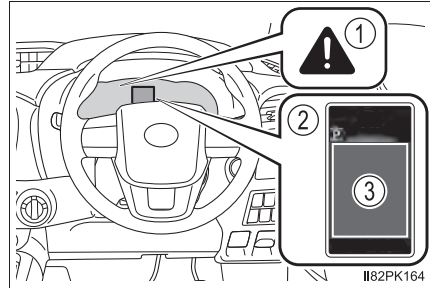

If any of the warning messages comes on again after the following actions have been performed, contact your Toyota dealer.

Messages and warnings

The warning lights and warning buzzers operate as follows depending on the content of the message. If a message indicates the need for inspection by a dealer, have the vehicle inspected by your Toyota dealer immediately.

	System warning light	Warning buzzer*	Warning
Comes on	Comes on	Sounds	Indicates an important situation, such as when a system related to driving is malfunctioning or that danger may result if the correction procedure is not performed
Comes on	—	Sounds	
—	Comes on or flashes	Sounds	Indicates an important situation, such as when the systems shown on the multi-information display may be malfunctioning
Flashes	—	Sounds	Indicates a situation, such as when damage to the vehicle or danger may result
Comes on	—	Does not sound	Indicates a condition, such as malfunction of electrical components, their condition, or indicates the need for maintenance
Flashes	—	Does not sound	Indicates a situation, such as when an operation has been performed incorrectly, or indicates how to perform an operation correctly

*: A buzzer sounds the first time a message is shown on the multi-information display.

■ Warning messages

The warning messages explained below may differ from the actual messages according to operation conditions and vehicle specifications.

■ If  is shown

The engine oil pressure is too low. (This warning message may be displayed if the vehicle is stopped on a slope. Move the vehicle to a level surface and check to see if the message goes off.)

Immediately stop the vehicle in a safe place and contact your Toyota dealer. Continuing to drive the vehicle may be dangerous.

■ If “Accelerator and Brake Pedals Pressed Simultaneously” is shown

The accelerator and brake pedal are being depressed simultaneously.

(→P. 151)

Release the accelerator pedal and depress the brake pedal.

■ If “Differential oil temp high Shift to 2WD mode Cooling time required” or “Differential oil temp high Cooling time required” is shown

The differential oil temperature is too high.

Turn the front-wheel drive control switch to H2, and reduce the vehicle speed or stop the vehicle in a safe place. (→P. 270)

■ If “Engine oil level low Add or replace” is shown

The engine oil level is low. (This warning message may be displayed if the vehicle is stopped on a slope. Move the vehicle to a level surface and check to see if the message goes off.)

Check the level of the engine oil and add or replace oil if necessary.

(→P. 345).

■ If “Power turned off to save battery” is shown

Power was turned off due to the automatic power off function.

Next time when starting the engine, increase the engine speed slightly and maintain that level for approximately 5 minutes to recharge the battery.

■ **If “DPF full Manual regeneration required See owner’s manual” is shown**

The deposit collected in the filter needs to be regenerated. (→P. 298)

■ **If “DPF Regeneration in progress” is shown**

Regeneration is being automatically carried out by the DPF system.
(→P. 297)

■ **If a message that indicates the malfunction of front camera is shown**

The following systems may be suspended until the problem shown in the message is resolved. (→P. 218, 421)

- PCS (Pre-Collision System)
- LDA (Lane Departure Alert With Yaw Assist Function)
- RSA (Road Sign Assist)
- Dynamic radar cruise control

■ **If a message that indicates the need for the shift lever operation is shown**

To prevent the shift lever from being operated incorrectly or the vehicle from moving unexpectedly, a message that requires shifting the shift lever may be shown on the multi-information display. In that case, follow the instruction of the message and shift the shift lever.

■ **If “See owner’s manual” is shown**

● If the following messages are shown, follow the instructions accordingly.

- “Transmission fluid temp high Stop in a safe place” (→P. 190)
- “Water accumulation in fuel filter” (→P. 363)

● If “Smart Entry & Start System malfunction” is shown, this may be a malfunction.

Immediately have the vehicle inspected by your Toyota dealer.

● If “Oil Pressure Low Stop in a Safe Place” is shown, there may be a malfunction. Immediately stop the vehicle in a safe place and contact your Toyota dealer. Continuing to drive the vehicle may be dangerous.

■ **If “Radar Cruise Control Temporarily Unavailable See Owner’s Manual” is shown**

The dynamic radar cruise control system is suspended temporarily or until the problem shown in the message is resolved. (causes and coping methods: →P. 218)

■ **If “Radar Cruise Control Unavailable” is shown**

The dynamic radar cruise control system cannot be used temporarily. Use the system when it becomes available again.

■ If “Visit your dealer” is shown

The system or part shown on the multi-information display is malfunctioning. Have the vehicle inspected by your Toyota dealer immediately.

■ Warning buzzer

In some cases, the buzzer may not be heard due to being in a noisy location or audio sound.

**WARNING****■ If a warning light comes on or a warning buzzer sounds when a warning message is shown**

Check and follow the message shown on the multi-information display. Failure to do so may result in death or serious injury.

**NOTICE****■ While the engine oil level warning is shown**

Continued engine operation with low engine oil will damage the engine.

■ If “Water accumulation in fuel filter See owner’s manual” is shown

Never drive the vehicle if the warning message is displayed. Continued driving with water accumulated in the fuel filter will damage the fuel injection pump.

If you have a flat tire

Your vehicle is equipped with a spare tire. The flat tire can be replaced with the spare tire.

For details about tires: →P. 364

WARNING

■ If you have a flat tire

Do not continue driving with a flat tire.

Driving even a short distance with a flat tire can damage the tire and the wheel beyond repair, which could result in an accident.

Before jacking up the vehicle

- Stop the vehicle in a safe place on a hard, flat surface.
- Set the parking brake.
- Shift the shift lever to P (automatic transmission) or R (manual transmission).
- Stop the engine.
- Turn on the emergency flashers. (→P. 410)

Location of the spare tire

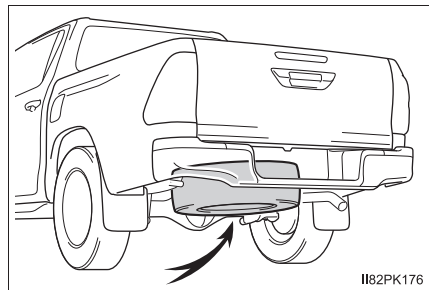

Location of the jack and tools

► Single-cab models

The jack and tools are stored behind the seat.

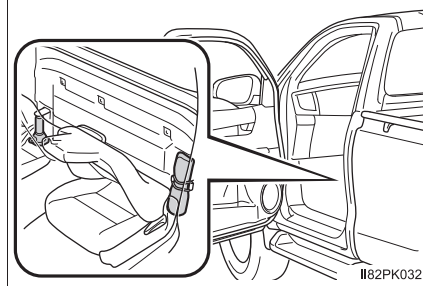

► Smart-cab models

The jack and tools are stored inside the rear seat side cover.

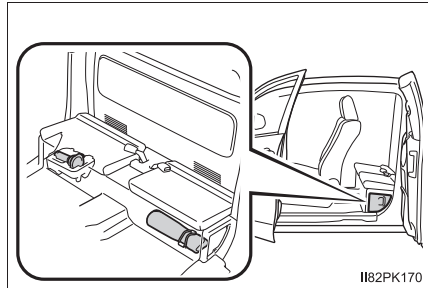

► Double-cab models

The jack and tools are stored under the bottom cushion.

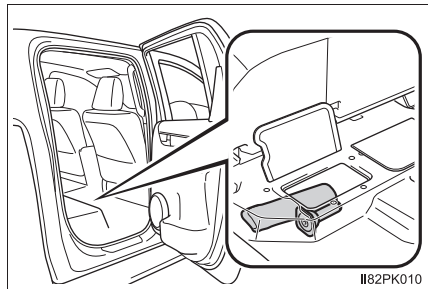

⚠ WARNING

■ **Using the tire jack**

Improper use of the tire jack may cause the vehicle to suddenly fall off the jack, leading to death or serious injury.

- Do not use the tire jack for any purpose other than replacing tires or installing and removing tire chains.
- Only use the tire jack that comes with this vehicle for replacing a flat tire. Do not use it on other vehicles, and do not use other tire jacks for replacing tires on this vehicle.
- Make sure the tire jack can be moved properly.
- Always check that the tire jack is securely set to the correct jack up point.
- Do not put any part of your body under the vehicle while it is supported by the jack.
- Do not start or run the engine while your vehicle is supported by the jack.
- Do not raise the vehicle while someone is inside.
- When raising the vehicle, do not put an object on or under the jack.
- Do not raise the vehicle to a height greater than that required to replace the tire.
- Do not continue jacking up once the yellow caution line has appeared.

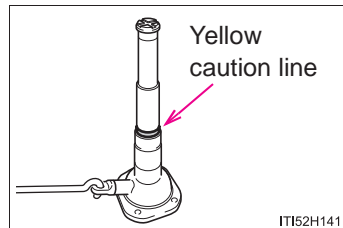

- Use a jack stand if it is necessary to get under the vehicle.

Take particular care when lowering the vehicle to ensure that no one working on or near the vehicle may be injured.

■ **Using the jack handle**

Insert the square head securely until you hear a click to prevent the extension parts from coming apart unexpectedly.

Taking out the jack and tool bag

▶ Single-cab models

- 1 Unhook the strap and take out the tool bag.

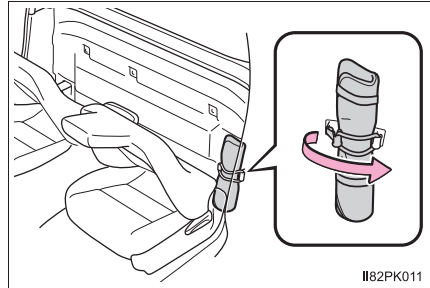

- 2 Take out the jack.

- ① For loosening
- ② For tightening

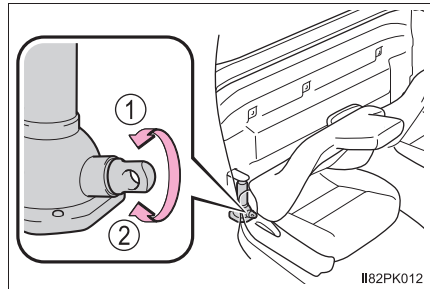

► Smart-cab models

1 Open the access panels. (→P. 116)

2 Remove the rear seat side cover.

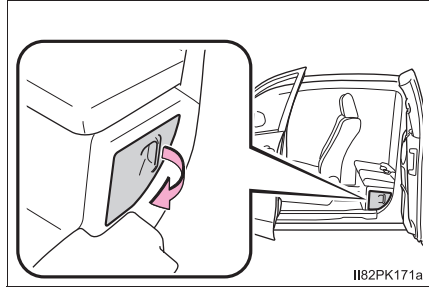

3 Unhook the strap and take out the tool bag.

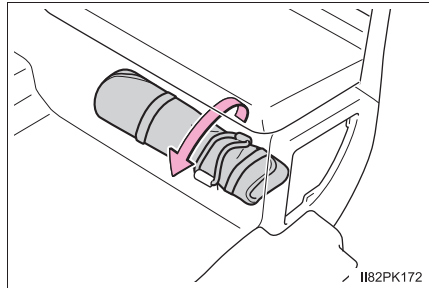

4 Take out the jack.

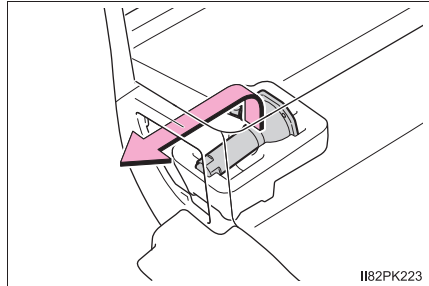

5 Install the rear seat side cover.

① Insert the tab of the cover as shown in the illustration.

② Push the cover to engage the 2 claws.

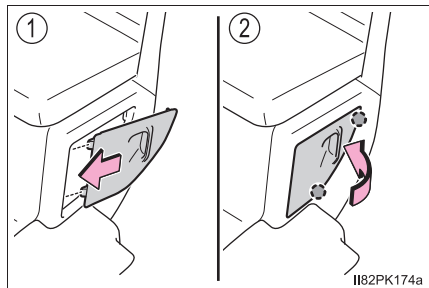

▶ Double-cab models

- 1 Tumbling the bottom cushion (→P. 129)
- 2 Open the lid.

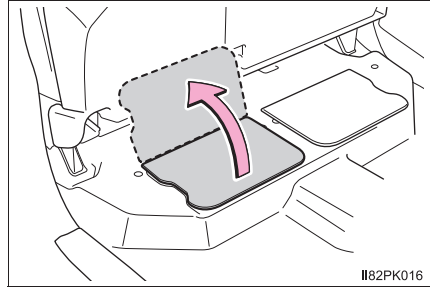

- 3 Take out the tool bag.

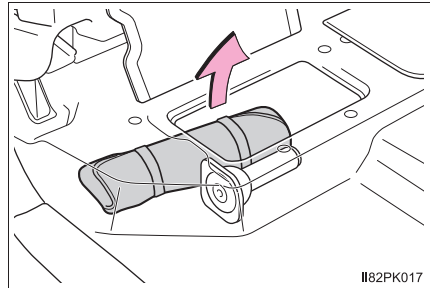

- 4 Take out the jack.
 - ① For loosening
 - ② For tightening

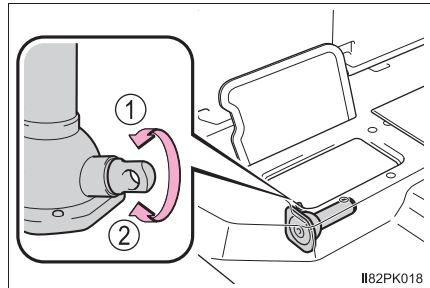

Taking out the spare tire

- 1 Assemble the jack handle end, jack handle extensions and wheel nut wrench.

To assemble the jack handle extension and wheel nut wrench, push in the projection on the jack handle extension.

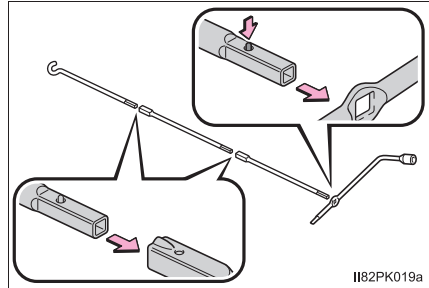

- 2 Insert the jack handle end into the lowering screw.

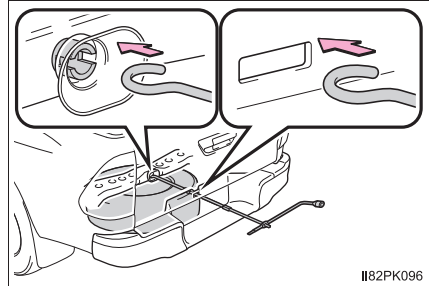

- 3 Lower the spare tire completely to the ground.

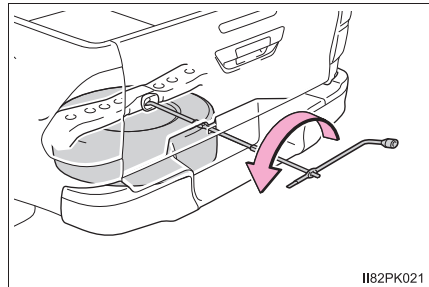

- 4 Remove the holding bracket and pull out the spare tire.

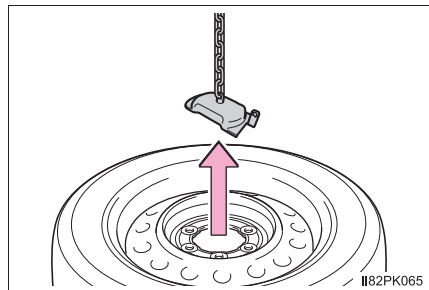

Replacing a flat tire

- 1 Chock the tires.

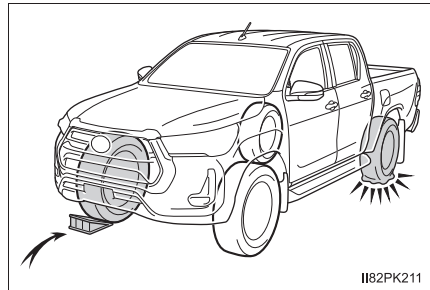

II82PK211

Flat tire		Wheel chock positions
Front	Left-hand side	Behind the rear right-hand side tire
	Right-hand side	Behind the rear left-hand side tire
Rear	Left-hand side	In front of the front right-hand side tire
	Right-hand side	In front of the front left-hand side tire

- 2 Remove the wheel ornament, using the beveled end of the wheel nut wrench as shown.

To protect the wheel ornament, place a rag between the wheel nut wrench and the wheel ornament.

► Type A

► Type B

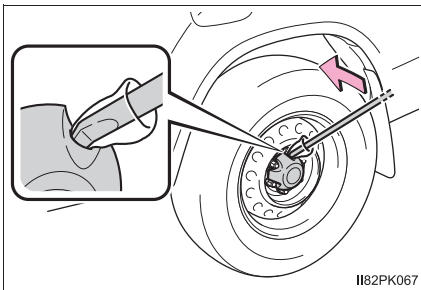

II82PK067

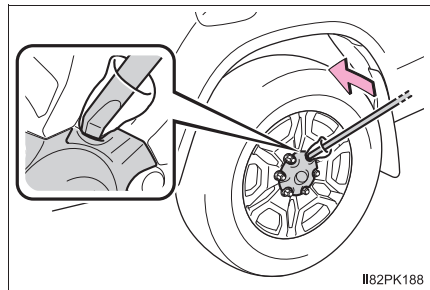

II82PK188

- 3 Slightly loosen the wheel nuts (one turn).

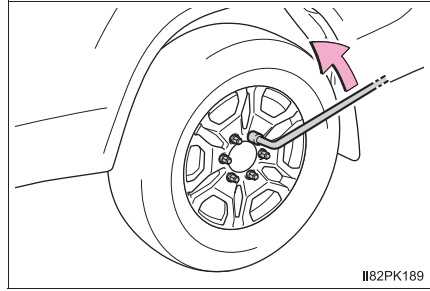

- 4 Assembling the jack handle. (→P. 437)
 5 Position the jack at the jack points as shown.

► Front

- ① 2WD models:
Under the front side rail
 ② 4WD models and Pre Runner:
Under the cross member

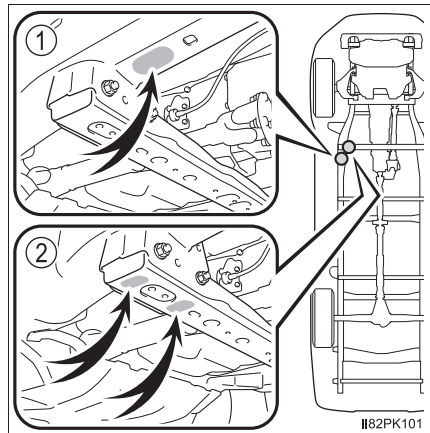

► Rear

Under the rear axle housing

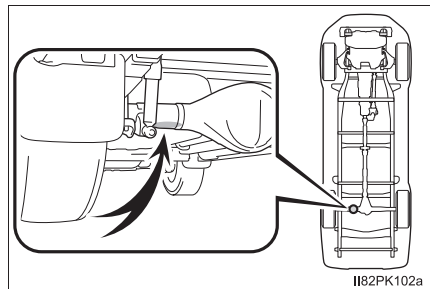

- 6 Raise the vehicle until the tire is slightly raised off the ground.

When positioning the jack under the rear axle housing, make sure the groove on the top of the jack fits with the rear axle housing.

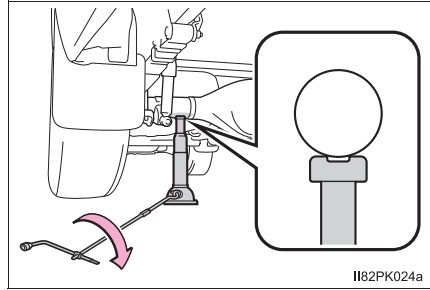

- 7 Remove all the wheel nuts and the tire.

When resting the tire on the ground, place the tire so that the wheel design faces up to avoid scratching the wheel surface.

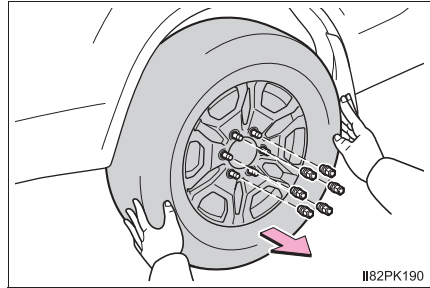

 **WARNING****■ Replacing a flat tire**

- Observe the following precautions.

Failure to do so may result in serious injury:

- Lower the spare tire completely to the ground before removing it from under the vehicle.
- Do not try to remove the wheel ornament by hand. Take due care in handling the ornament to avoid unexpected personal injury.
- Do not touch the disc wheels or the area around the brakes immediately after the vehicle has been driven.

After the vehicle has been driven the disc wheels and the area around the brakes will be extremely hot. Touching these areas with hands, feet or other body parts while changing a tire, etc. may result in burns.

- Failure to follow these precautions could cause the wheel nuts to loosen and the tire to fall off, resulting in death or serious injury.
 - 2WD models: Have the wheel nuts tightened with a torque wrench to 152 N•m (15.5 kgf•m, 112 ft•lbf) (steel wheels), or 121 N•m (12.3 kgf•m, 89 ft•lbf) (aluminum wheels) as soon as possible after changing wheels.
 - 4WD models and Pre Runner: Have the wheel nuts tightened with a torque wrench to 105 N•m (10.7 kgf•m, 77 ft•lbf) as soon as possible after changing wheels.
 - Do not attach a heavily damaged wheel ornament, as it may fly off the wheel while the vehicle is moving.
 - When installing a tire, only use wheel nuts that have been specifically designed for that wheel.
 - If there are any cracks or deformations in the bolt screws, nut threads or bolt holes of the wheel, have the vehicle inspected by your Toyota dealer.
 - When installing the wheel nuts, be sure to install them with the tapered ends facing inward.

Installing the spare tire

- 1 Remove any dirt or foreign matter from the wheel contact surface.

If foreign matter is on the wheel contact surface, the wheel nuts may loosen while the vehicle is in motion, causing the tire to come off.

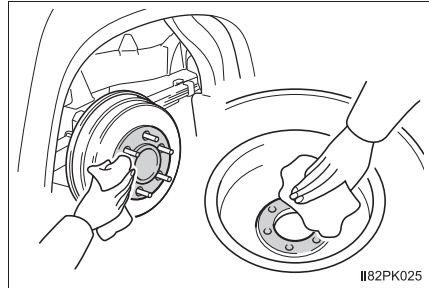

- 2 Install the tire and loosely tighten each wheel nut by hand by approximately the same amount.

When replacing a steel wheel with a steel wheel, tighten the wheel nuts until the tapered portion comes into loose contact with the disc wheel seat.

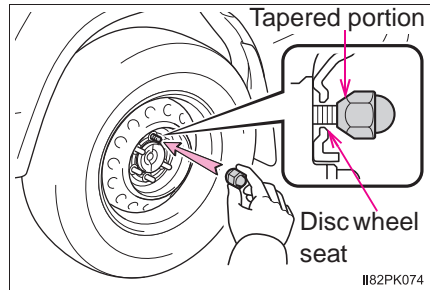

When replacing an aluminum wheel with a steel wheel, tighten the wheel nuts until the tapered portion comes into loose contact with the disc wheel seat.

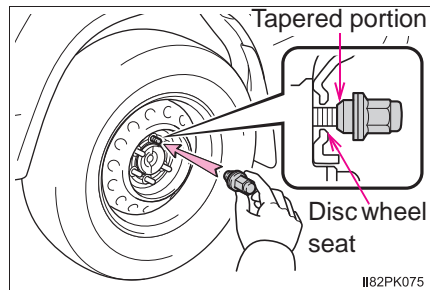

When replacing an aluminum wheel with an aluminum wheel, turn the wheel nuts until the washers come into contact with the disc wheel.

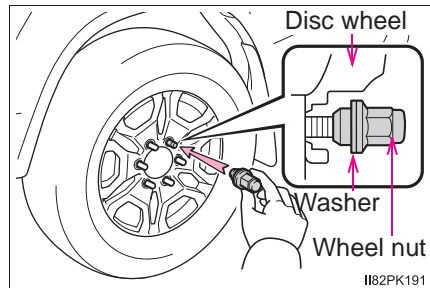

- 3 Lower the vehicle.

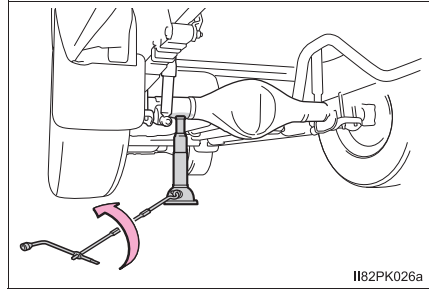

- 4 Firmly tighten each wheel nut two or three times in the order shown in the illustration.

- 2WD models

Tightening torque:

Steel wheels

152 N•m (15.5 kgf•m, 112 ft•lbf)

Aluminum wheels

121 N•m (12.3 kgf•m, 89 ft•lbf)

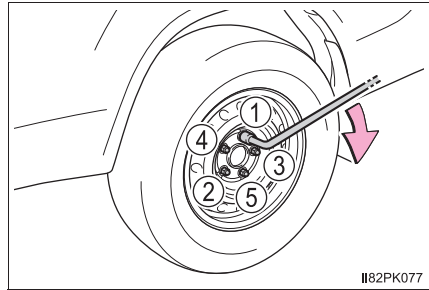

- 4WD models and Pre Runner

Tightening torque:

105 N•m (10.7 kgf•m, 77 ft•lbf)

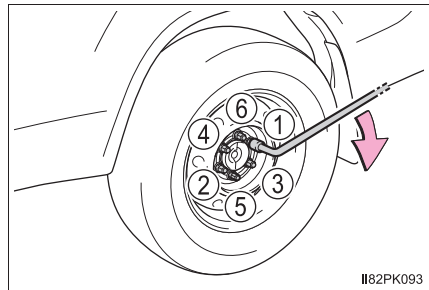

- 5 Vehicles with spare tire of the same wheel type as the installed tires: Reinstall the wheel ornament.

► Type A

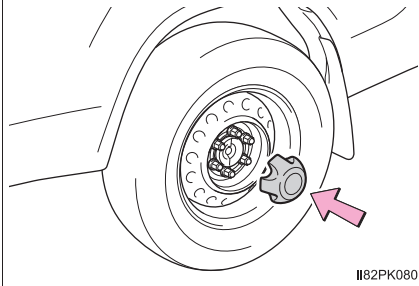

► Type B

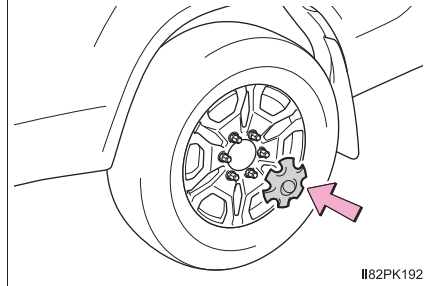

! WARNING

■ **Stowing the flat tire**

Failure to follow steps listed under stowing the tire may result in damage to the spare tire carrier and loss of the tire, which could result in death or serious injury.

Stowing the flat tire, jack and all tools

- 1 Lay down the tire with the valve stem facing up and install the holding bracket, inserting the claw into the wheel lug nut hole. Turn the jack handle extension clockwise to take up slack in the chain.

Then, check to ensure the claw is in the wheel lug nut hole and the holding bracket is centered in the wheel hub.

- ① Holding bracket
- ② Claw

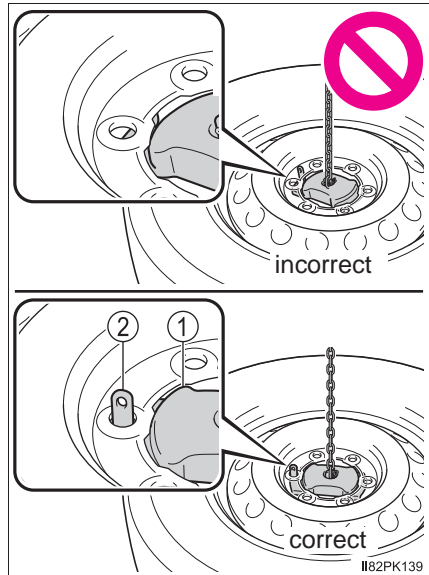

- 2 Raise the tire.

To protect the wheel design faces, place rags between the wheel design faces and the frame.

While raising, secure the tire, taking care that the tire goes straight up without catching on any surrounding part, to prevent it from flying forward during a collision or sudden braking.

After the tire goes half way up, check that the suspended chain is able to enter the tire hole, for proper storage.

Tightening torque:

37.0 N•m (3.8 kgf•m, 27.3 ft•lbf)

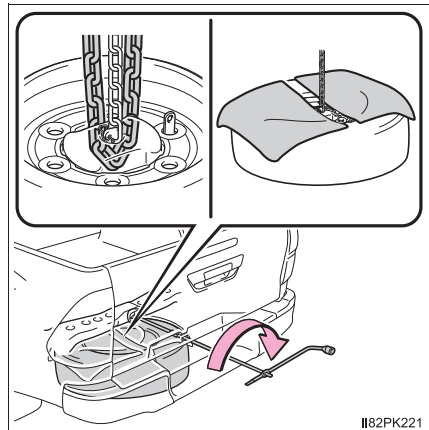

- 3 Confirm that the tire is not loose after tightening:

- 1 Push and pull the tire
- 2 Try rotating

Visually check to ensure the tire is not hung on surrounding parts.

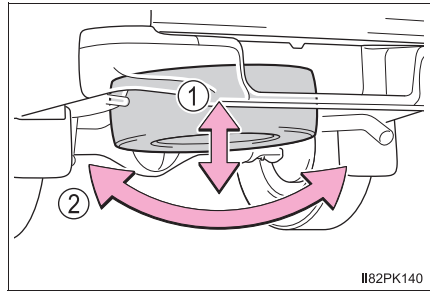

If looseness or misassembly exists, repeat step 2 and step 3.

- 4 Repeat step 3, any time the tire is lowered or disturbed.

- 5 Push in the projection on the jack handle and disassemble the jack handle end, jack handle extensions and wheel nut wrench.

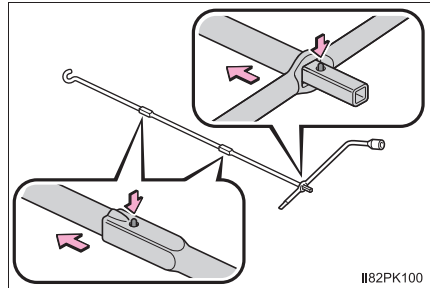

- 6 Stow the tools and jack securely.

 **WARNING****■ After using the tools and jack**

Before driving, make sure all the tools and jack are securely in place in their storage location to reduce the possibility of personal injury during a collision or sudden braking.

 **NOTICE****■ When stowing the flat tire**

Ensure that there is no object caught between the tire and the vehicle underbody. (except for rags that protecting the wheel design faces)

■ When assembling the jack handle extension

Insert the square head securely until you hear a click. Otherwise the extension may come off and it may damage the paint or vehicle body.

If the engine will not start

If the engine will not start even though correct starting procedures are being followed (→P. 173, 176), consider each of the following points:

The engine will not start even though the starter motor operates normally.

One of the following may be the cause of the problem:

- There may not be sufficient fuel in the vehicle's tank.
Gasoline engine: Refuel the vehicle.
Diesel engine: →P. 462
- The engine may be flooded. (gasoline engine)
Try to restart the engine again following correct starting procedures.
(→P. 173, 176)
- There may be a malfunction in the engine immobilizer system.
(→P. 77)

The starter motor turns over slowly, the interior lights and headlights are dim, or the horn does not sound or sounds at a low volume.

One of the following may be the cause of the problem:

- The battery may be discharged. (→P. 454)
- The battery terminal connections may be loose or corroded.

The starter motor does not turn over (vehicles with smart entry & start system).

The engine starting system may be malfunctioning due to an electrical problem such as an open circuit or a blown fuse. However, an interim measure is available to start the engine. (→P. 449)

The starter motor does not turn over, the interior lights and headlights do not turn on, or the horn does not sound.

One of the following may be the cause of the problem:

- One or both of the battery terminals may be disconnected.
- The battery may be discharged. (→P. 454)
- There may be a malfunction in the steering lock system. (vehicles with smart entry & start system)

Contact your Toyota dealer if the problem cannot be repaired, or if repair procedures are unknown.

Emergency start function (vehicles with smart entry & start system)

When the engine does not start, the following steps can be used as an interim measure to start the engine if the engine switch is functioning normally.

- 1 Set the parking brake.
- 2 Shift the shift lever to P (automatic transmission) or N (manual transmission).
- 3 Turn the engine switch to ACCESSORY mode.
- 4 Press and hold the engine switch for about 15 seconds while depressing the brake pedal and clutch pedal (manual transmission) firmly.

Even if the engine can be started using the above steps, the system may be malfunctioning. Have the vehicle inspected by your Toyota dealer.

If the electronic key does not operate properly (vehicles with smart entry & start system)

If communication between the electronic key and vehicle is interrupted (→P. 123) or the electronic key cannot be used because the battery is depleted, the smart entry & start system and wireless remote control cannot be used. In such cases, the doors can be opened and the engine can be started by following the procedure below.

Locking and unlocking the doors

Use the mechanical key (→P. 106, 108) in order to perform the following operations:

- ① Locks all doors
- ② Unlocks all doors

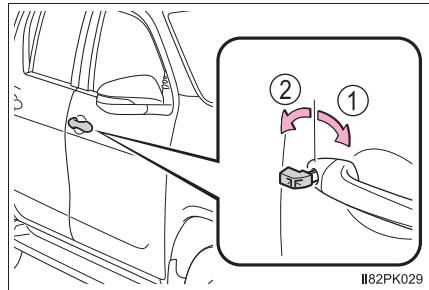

Starting the engine

► Automatic transmission

- 1 Ensure that the shift lever is in P and depress the brake pedal.
- 2 Touch the area behind the lock button and unlock button on the electronic key to the engine switch.

When the electronic key is detected, a buzzer sounds and the engine switch will turn to IGNITION ON mode.

When the smart entry & start system is deactivated in customization setting, the engine switch will turn to ACCESSORY mode.

- 3 Firmly depress the brake pedal.

A message indicating how to start the engine will be displayed on the multi-information display.

- 4 Press the engine switch.

In the event that the engine still cannot be started, contact your Toyota dealer.

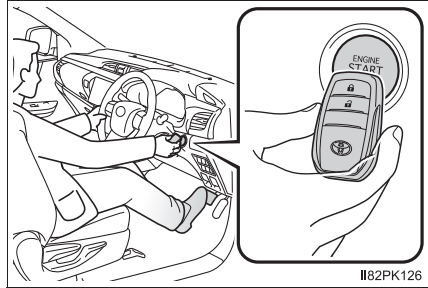

► Manual transmission

- 1 Ensure that the shift lever is in N and depress the clutch pedal.
- 2 Touch the area behind the lock button and unlock button on the electronic key to the engine switch.

When the electronic key is detected, a buzzer sounds and the engine switch will turn to IGNITION ON mode.

When the smart entry & start system is deactivated in customization setting, the engine switch will turn to ACCESSORY mode.

- 3 Firmly depress the clutch pedal.

A message indicating how to start the engine will be displayed on the multi-information display.

- 4 Press the engine switch.

In the event that the engine still cannot be started, contact your Toyota dealer.

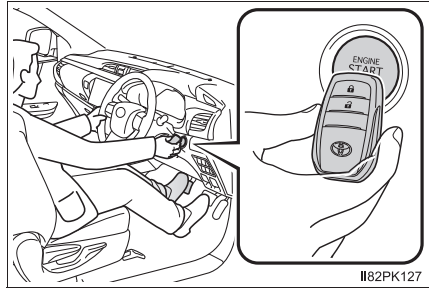

■ Stopping the engine

Shift the shift lever to P (automatic transmission) or N (manual transmission) and press the engine switch as you normally do when stopping the engine.

■ Replacing the key battery

As the above procedure is a temporary measure, it is recommended that the electronic key battery be replaced immediately when the battery is depleted. (→P. 373)

■ Changing engine switch modes

Release the brake pedal (automatic transmission) or clutch pedal (manual transmission) and press the engine switch in step **3** above.

The engine does not start and modes will be changed each time the switch is pressed. (→P. 179)

■ When the electronic key does not work properly

- Make sure that the smart entry & start system has not been deactivated in the customization setting. If it is off, turn the function on. (Customizable features: →P. 483)
- Check if battery-saving mode is set. If it is set, cancel the function. (→P. 121)

If the vehicle battery is discharged

The following procedures may be used to start the engine if the vehicle's battery is discharged.

You can also call your Toyota dealer or a qualified repair shop.

If you have a set of jumper (or booster) cables and a second vehicle with a 12-volt battery, you can jump start your vehicle by following the steps below.

- 1 Open the hood. (→P. 349)
- 2 Connect the jumper cables according to the following procedure:
 - ① Connect a positive jumper cable clamp to the positive (+) battery terminal on your vehicle.
 - ② Connect the clamp on the other end of the positive cable to the positive (+) battery terminal on the second vehicle.
 - ③ Connect a negative cable clamp to the negative (-) battery terminal on the second vehicle.
 - ④ Connect the clamp at the other end of the negative cable to a solid, stationary, unpainted metallic point away from the battery and any moving parts, as shown in the illustration.

► Gasoline engine

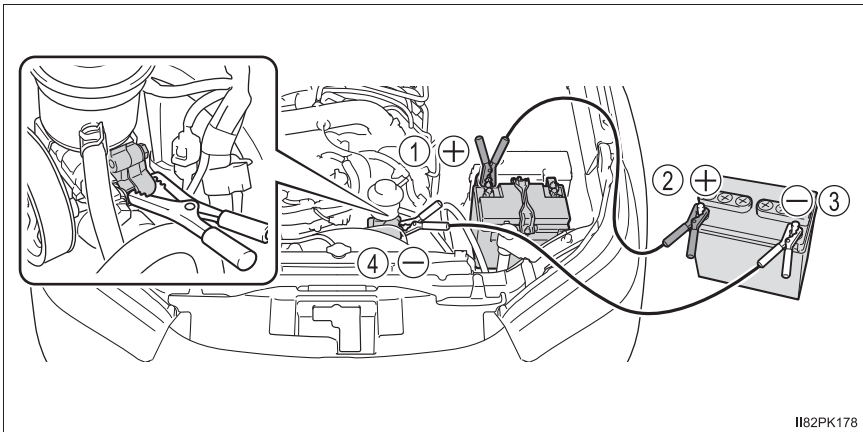

► Diesel engine

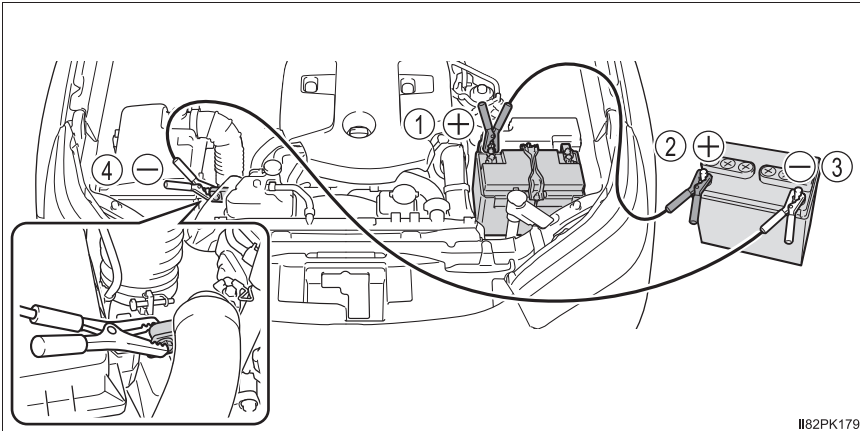

- 3 Start the engine of the second vehicle. Increase the engine speed slightly and maintain at that level for approximately 5 minutes to recharge the battery of your vehicle.
- 4 Vehicles with smart entry & start system: Open and close any of the doors with the engine switch off.
- 5 Maintain the engine speed of the second vehicle and start the engine of your vehicle by turning the engine switch to the “ON” position (vehicles without smart entry & start system) or IGNITION ON mode (vehicles with smart entry & start system).
- 6 Once the vehicle’s engine has started, remove the jumper cables in the exact reverse order from which they were connected.

Once the engine starts, have the vehicle inspected at your Toyota dealer as soon as possible.

■ Starting the engine when the battery is discharged (vehicles with automatic transmission)

The engine cannot be started by push-starting.

■ To prevent battery discharge

- Turn off the headlights and the audio system while the engine is off.
- Turn off any unnecessary electrical components when the vehicle is running at a low speed for an extended period, such as in heavy traffic.

■ When the battery is removed or discharged

- Information stored in the ECU is cleared. When the battery is depleted, have the vehicle inspected at your Toyota dealer.
- The power windows may not close normally. In this case, initialize the power windows. (→P. 144)

■ Charging the battery

The electricity stored in the battery will discharge gradually even when the vehicle is not in use, due to natural discharge and the draining effects of certain electrical appliances. If the vehicle is left for a long time, the battery may discharge, and the engine may be unable to start. (The battery recharges automatically during driving.)

■ When recharging or replacing the battery (vehicles with smart entry & start system)

- In some cases, it may not be possible to unlock the doors using the smart entry & start system when the battery is discharged. Use the wireless remote control or the mechanical key to lock or unlock the doors.
- The engine may not start on the first attempt after the battery has recharged but will start normally after the second attempt. This is not a malfunction.
- The engine switch mode is memorized by the vehicle. When the battery is reconnected, the system will return to the mode it was in before the battery was discharged. Before disconnecting the battery, turn the engine switch off. If you are unsure what mode the engine switch was in before the battery discharged, be especially careful when reconnecting the battery.

■ When replacing the battery

- Use a battery that conforms to European regulations.
- Use a battery with the same case size as the previous battery and an equivalent 20 hour rate capacity (20HR) or greater.
 - If the sizes differ, the battery cannot be properly secured.
 - If the 20 hour rate capacity is low, even if the time period where the vehicle is not used is a short time, the battery may discharge and the engine may not be able to start.
- For details, consult your Toyota dealer.

 **WARNING****■ When removing the battery terminals**

Always remove the negative (-) terminal first. If the positive (+) terminal contacts any metal in the surrounding area when the positive (+) terminal is removed, a spark may occur, leading to a fire in addition to electrical shocks and death or serious injury.

■ Avoiding battery fires or explosions

Observe the following precautions to prevent accidentally igniting the flammable gas that may be emitted from the battery:

- Make sure each jumper cable is connected to the correct terminal and that it is not unintentionally in contact with any other than the intended terminal.
- Do not allow the other end of the jumper cable connected to the “+” terminal to come into contact with any other parts or metal surfaces in the area, such as brackets or unpainted metal.
- Do not allow the + and - clamps of the jumper cables to come into contact with each other.
- Do not smoke, use matches, cigarette lighters or allow open flame near the battery.

 **WARNING****■ Battery precautions**

The battery contains poisonous and corrosive acidic electrolyte, while related parts contain lead and lead compounds. Observe the following precautions when handling the battery:

- When working with the battery, always wear safety glasses and take care not to allow any battery fluids (acid) to come into contact with skin, clothing or the vehicle body.
- Do not lean over the battery.
- In the event that battery fluid comes into contact with the skin or eyes, immediately wash the affected area with water and seek medical attention. Place a wet sponge or cloth over the affected area until medical attention can be received.
- Always wash your hands after handling the battery support, terminals, and other battery-related parts.
- Do not allow children near the battery.

■ When exchanging the battery

- When the vent plug and indicator are close to the hold down bracket, the battery fluid (sulfuric acid) may leak.
- For information regarding battery replacement, contact your Toyota dealer.

■ To prevent damage to the vehicle (vehicles with manual transmission)

Do not pull- or push-start the vehicle as the three-way catalytic converter or catalytic converter may overheat and become a fire hazard.

 **NOTICE****■ When handling jumper cables**

When connecting the jumper cables, ensure that they do not become entangled in the cooling fan or belt.

If your vehicle overheats

The following may indicate that your vehicle is overheating.

- The needle of the engine coolant temperature gauge (→P. 89) enters the red zone or a loss of engine power is experienced. (For example, the vehicle speed does not increase.)
- Steam comes out from under the hood.

Correction procedures

- 1 Stop the vehicle in a safe place and turn off the air conditioning system, and then stop the engine.
- 2 If you see steam:
Carefully lift the hood after the steam subsides.
If you do not see steam:
Carefully lift the hood.
- 3 After the engine has cooled down sufficiently, inspect the hoses and radiator core (radiator) for any leaks.

① Radiator

② Cooling fan

If a large amount of coolant leaks, immediately contact your Toyota dealer.

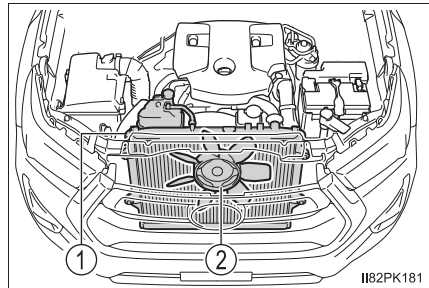

- 4 The coolant level is satisfactory if it is between the “F” and “L” lines on the reservoir.

① Reservoir

② “F” line

► Gasoline engine

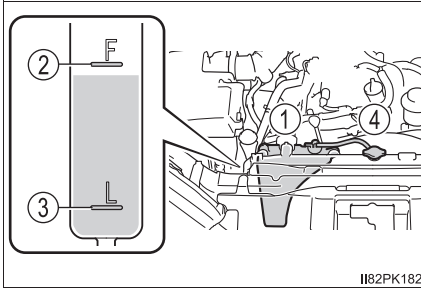

II82PK182

③ “L” line

④ Radiator cap (if equipped)

► Diesel engine

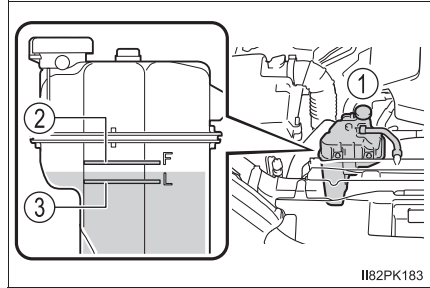

II82PK183

- 5 Add engine coolant if necessary. (→P. 474)

Water can be used in an emergency if engine coolant is unavailable.

► Gasoline engine

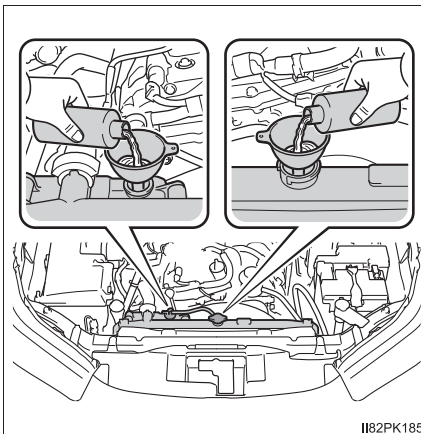

II82PK185

► Diesel engine

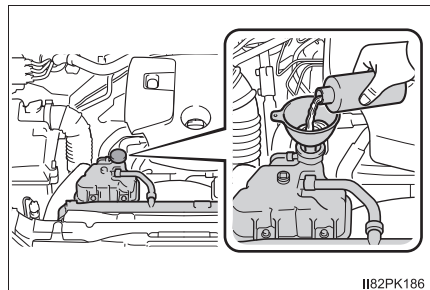

II82PK186

- 6 Start the engine to check that the radiator cooling fan operates and to check for coolant leaks from the radiator or hoses.

- 7 If the fan is not operating:
Stop the engine immediately and contact your Toyota dealer.
If the fan is operating:
Have the vehicle inspected at the nearest Toyota dealer.

 **WARNING****■ When inspecting under the hood of your vehicle**

Observe the following precautions.

Failure to do so may result in serious injury such as burns.

- If steam is seen coming from under the hood, do not open the hood until the steam has subsided. The engine compartment may be very hot.
- Keep hands and clothing (especially a tie, a scarf or a muffler) away from the fans and belts. Failure to do so may cause the hands or clothing to be caught, resulting in serious injury.
- Do not loosen the radiator cap or the coolant reservoir cap while the engine and radiator are hot. High temperature steam or coolant could spray out.

 **NOTICE****■ When adding engine coolant**

Add coolant slowly after the engine has cooled down sufficiently. Adding cool coolant to a hot engine too quickly can cause damage to the engine.

■ To prevent damage to the cooling system

Observe the following precautions:

- Avoid contaminating the coolant with foreign matter (such as sand or dust etc.).
- Do not use any coolant additive.

If you run out of fuel and the engine stalls (diesel engine only)

If you run out of fuel and the engine stalls:

- 1 Refuel your vehicle.
- 2 To bleed the fuel system, operate the priming pump until you feel more resistance.

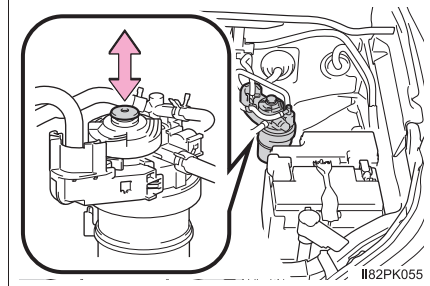

- 3 Start the engine. (→P. 173, 176)

If the engine does not start after the above steps have been performed, wait for 10 seconds and try steps **2** and **3** again. If the engine still does not start, contact your Toyota dealer.

After starting the engine, depress the accelerator pedal lightly until the engine runs smoothly.

NOTICE

■ When restarting the engine

- Do not crank the engine before refueling and operating the priming pump. This may damage the engine and fuel system.
- Do not crank the engine for more than 30 seconds at a time. This may overheat the starter and wiring system.

If the vehicle becomes stuck

Carry out the following procedures if the tires spin or the vehicle becomes stuck in mud, dirt or snow:

- 1 Stop the engine. Set the parking brake and shift the shift lever to P (automatic transmission) or N (manual transmission).
- 2 Remove the mud, snow or sand from around the stuck tire.
- 3 Place wood, stones or some other material under the tires to help provide traction.
- 4 Restart the engine.
- 5 Vehicles with rear differential lock system: Lock the rear differential. (→P. 280)
- 6 Shift the shift lever to the D or R position (automatic transmission) or 1 or R position (manual transmission) and carefully apply the accelerator to free the vehicle.

■ When it is difficult to free the vehicle

Press  to turn off TRC/A-TRC.

- ▶ Vehicles without AUTO LSD system

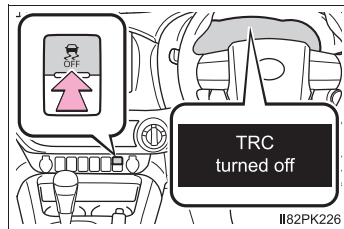

- ▶ Vehicles with AUTO LSD system

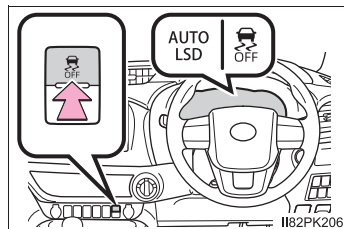

 **WARNING****■ When attempting to free a stuck vehicle**

If you choose to push the vehicle back and forth to free it, make sure the surrounding area is clear to avoid striking other vehicles, objects or people. The vehicle may also lunge forward or lunge back suddenly as it becomes free. Use extreme caution.

■ When shifting the shift lever

For vehicles with automatic transmission, be careful not to shift the shift lever with the accelerator pedal depressed.

This may lead to unexpected rapid acceleration of the vehicle that may cause an accident resulting in death or serious injury.

 **NOTICE****■ To avoid damage to the transmission and other components**

- Avoid spinning the wheels and depressing the accelerator pedal more than necessary.
- If the vehicle remains stuck even after these procedures are performed, the vehicle may require towing to be freed.
- Vehicles with automatic transmission: When a warning message for the automatic transmission fluid temperature is displayed while attempting to free a stuck vehicle, immediately remove your foot from the accelerator pedal and wait until the warning message disappears. Otherwise, the transmission may become damaged. (→P. 190)

Vehicle specifications

8

8-1. Specifications

Maintenance data (fuel, oil level, etc.).....	466
Fuel information	481

8-2. Customization

Customizable features	483
-----------------------------	-----

Maintenance data (fuel, oil level, etc.)

Dimensions

Overall length	Without over fender	Without rear bumper	5265 mm (207.3 in.) ^{*2} 5285 mm (208.1 in.) ^{*3}
		With rear bumper	5335 mm (210.0 in.)
	With over fender	Without rear bumper	5255 mm (206.9 in.) ^{*2} 5275 mm (207.7 in.) ^{*3}
		With rear bumper	5325 mm (209.6 in.)
Overall width	Without over fender		1800 mm (70.9 in.) ^{*4} 1815 mm (71.5 in.) ^{*5}
	With over fender		1855 mm (73.0 in.) ^{*6} 1900 mm (74.8 in.) ^{*7}
Overall height ^{*1}	2WD models	Single-cab models	1690 mm (66.5 in.)
		Double-cab models	1700 mm (66.9 in.)
	4WD models and Pre Runner	Single-cab models	1795 mm (70.7 in.)
		Smart-cab models	1810 mm (71.3 in.)
		Double-cab models	1815 mm (71.5 in.)
Wheelbase	2WD models		3085 mm (121.5 in.)
	4WD models and Pre Runner		3090 mm (121.7 in.)
Front tread	2WD models		1510 mm (59.4 in.)
	4WD models and Pre Runner		1495 mm (58.9 in.) ^{*9} 1535 mm (60.4 in.) ^{*10}
Rear tread	2WD models		1510 mm (59.4 in.)
	4WD models and Pre Runner		1510 mm (59.4 in.) ^{*9} 1550 mm (61.0 in.) ^{*10}

- *1: Unladen vehicle
- *2: With tailgate type A (→P. 117)
- *3: With tailgate type B (→P. 117)
- *4: Without side step
- *5: With side step
- *6: With exterior type A *8
- *7: With exterior type B *8
- *8: See “How to identify exterior type” to check the type of your vehicle.
(→P. 467)
- *9: With 225/70R17C tires
- *10: With 265/65R17 or 265/60R18 tires

■ How to identify exterior type

Check the type of the exterior in the following illustrations.

▶ Type A

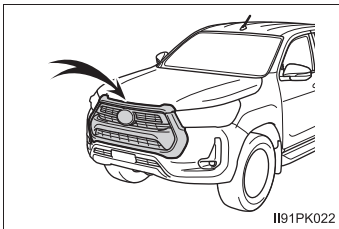

▶ Type B

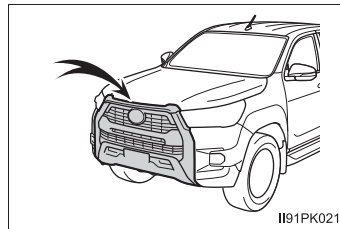

Vehicle identification

■ Vehicle identification number

The vehicle identification number (VIN) is the legal identifier for your vehicle. This is the primary identification number for your Toyota. It is used in registering the ownership of your vehicle.

This number is stamped on the rear right frame.

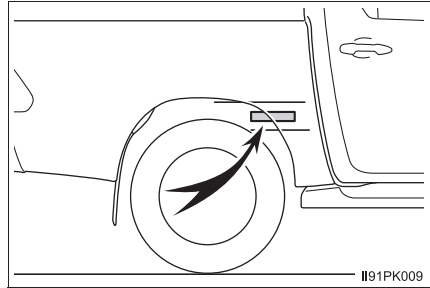

This number is also on the manufacturer's plate.

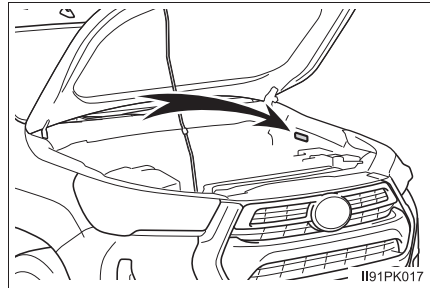

■ Engine number

The engine number is stamped on the engine block as shown.

▶ Gasoline engine

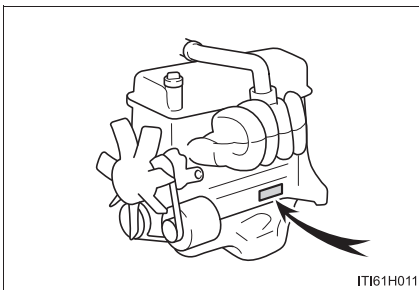

▶ Diesel engine

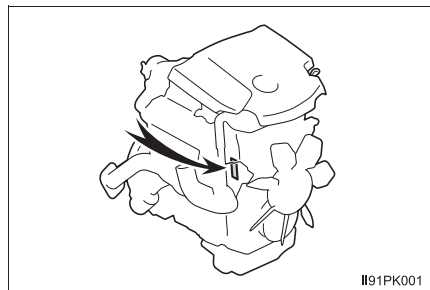

Engine

▶ 2TR-FE engine

Model	2TR-FE
Type	4 cylinder in line, 4 cycle, gasoline
Bore and stroke	95.0 × 95.0 mm (3.74 × 3.74 in.)
Displacement	2694 cm ³ (164.4 cu.in.)
Valve clearance	Automatic adjustment
Drive belt tension	Automatic adjustment

▶ 1GD-FTV engine

Model	1GD-FTV
Type	4 cylinder in line, 4 cycle, diesel (with turbocharger)
Bore and stroke	92.0 × 103.6 mm (3.62 × 4.08 in.)
Displacement	2755 cm ³ (168.1 cu.in.)
Valve clearance	Automatic adjustment
Drive belt tension	Automatic adjustment

▶ 2GD-FTV engine

Model	2GD-FTV
Type	4 cylinder in line, 4 cycle, diesel (with turbocharger)
Bore and stroke	92.0 × 90.0 mm (3.62 × 3.54 in.)
Displacement	2393 cm ³ (146.0 cu.in.)
Valve clearance	Automatic adjustment
Drive belt tension	Automatic adjustment

Fuel

▶ Gasoline engine

Fuel type	Unleaded gasoline only
Research Octane Number	91 or higher
Fuel tank capacity (Reference)	80 L (21.1 gal., 17.6 Imp.gal.)

▶ Diesel engine

Fuel type	Diesel fuel that contains 10 ppm or less of sulfur
Cetane number	48 or higher
Fuel tank capacity (Reference)	80 L (21.1 gal., 17.6 Imp.gal.)

Lubrication system

► Gasoline engine

Oil capacity (Drain and refill — reference*)	
With filter	5.6 L (5.9 qt., 4.9 Imp.qt.)
Without filter	5.3 L (5.6 qt., 4.7 Imp.qt.)

*: The engine oil capacity is a reference quantity to be used when changing the engine oil. Warm up and turn off the engine, wait more than 5 minutes, and check the oil level on the dipstick.

■ Engine oil selection

“Toyota Genuine Motor Oil” is used in your Toyota vehicle. Use Toyota approved “Toyota Genuine Motor Oil” or equivalent to satisfy the following grade and viscosity.

Oil grade:

0W-20, 5W-20, 5W-30 and 10W-30:

API grade SL “Energy-Conserving”, SM “Energy-Conserving”, SN “Resource-Conserving” or SN PLUS “Resource-Conserving”; or ILSAC multigrade engine oil

Recommended viscosity (SAE):

SAE 0W-20 is filled into your Toyota vehicle at manufacturing, and the best choice for good fuel economy and good starting in cold weather.

If you use SAE 10W-30 or a higher viscosity engine oil in extremely low temperatures, the engine may become difficult to start, so SAE 0W-20, 5W-20 or 5W-30 engine oil is recommended.

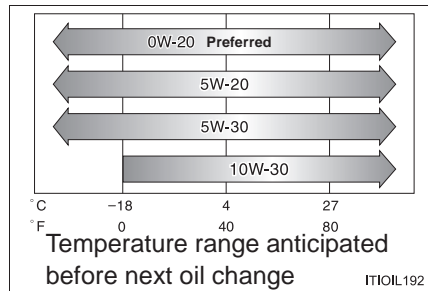

Oil viscosity (0W-20 is explained here as an example):

- The 0W in 0W-20 indicates the characteristic of the oil which allows cold startability. Oils with a lower value before the W allow for easier starting of the engine in cold weather.
- The 20 in 0W-20 indicates the viscosity characteristic of the oil when the oil is at high temperature. An oil with a higher viscosity (one with a higher value) may be better suited if the vehicle is operated at high speeds, or under extreme load conditions.

How to read oil container labels:

Either or both API registered marks are added to some oil containers to help you select the oil you should use.

① API Service Symbol

Top portion: "API SERVICE SN" means the oil quality designation by American Petroleum Institute (API).

Center portion: "SAE 0W-20" means the SAE viscosity grade.

Lower portion: "Resource-Conserving" means that the oil has fuel-saving and environmental protection capabilities.

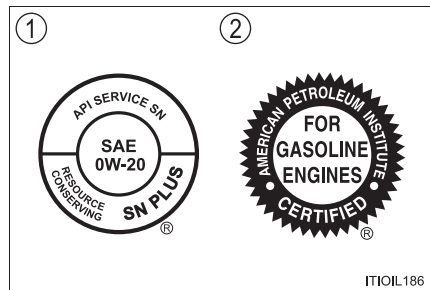

② ILSAC Certification Mark

The International Lubricant Specification Advisory Committee (ILSAC) Certification Mark is displayed on the front of the container.

► Diesel engine

Oil capacity (Drain and refill — reference*)	
With filter	7.5 L (7.9 qt., 6.6 Imp.qt.)
Without filter	7.0 L (7.4 qt., 6.2 Imp.qt.)

*: The engine oil capacity is a reference quantity to be used when changing the engine oil. Warm up and turn off the engine, wait more than 5 minutes, and check the oil level on the dipstick.

■ Engine oil selection

“Toyota Genuine Motor Oil” is used in your Toyota vehicle. Toyota recommends the use of approved “Toyota Genuine Motor Oil”. Another motor oil of matching quality can also be used.

Oil grade: ACEA C2

⚠ NOTICE

Using engine oil other than ACEA C2 may damage the catalytic converter.

Recommended viscosity (SAE):

SAE 0W-30 is filled into your Toyota vehicle at manufacturing, and the best choice for good fuel economy and good starting in cold weather.

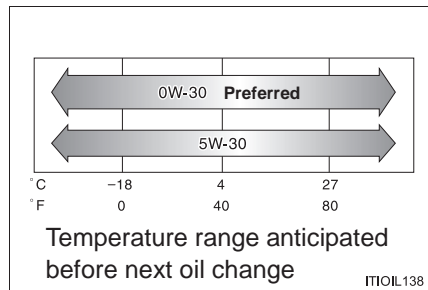

Oil viscosity (0W-30 is explained here as an example):

- The 0W in 0W-30 indicates the characteristic of the oil which allows cold startability. Oils with a lower value before the W allow for easier starting of the engine in cold weather.
- The 30 in 0W-30 indicates the viscosity characteristic of the oil when the oil is at high temperature. An oil with a higher viscosity (one with a higher value) may be better suited if the vehicle is operated at high speeds, or under extreme load conditions.

Cooling system

Capacity	Gasoline engine	<ul style="list-style-type: none"> ▶ With automatic transmission 8.1 L (8.6 qt., 7.1 Imp.qt.) ▶ With manual transmission 7.8 L (8.2 qt., 6.9 Imp.qt.)
	Diesel engine	<ul style="list-style-type: none"> ▶ With automatic transmission 9.3 L (9.8 qt., 8.2 Imp.qt.) ▶ With manual transmission 8.7 L (9.2 qt., 7.7 Imp.qt.)
Coolant type	<p>Use either of the following:</p> <ul style="list-style-type: none"> • “Toyota Super Long Life Coolant” • Similar high-quality ethylene glycol-based non-silicate, non-amine, non-nitrite, and non-borate coolant with long-life hybrid organic acid technology <p>Do not use plain water alone.</p>	

Ignition system (gasoline engine)

Spark plug	
Make	DENSO FK20HR-A8
Gap	0.8 mm (0.031 in.)

NOTICE

■ Iridium-tipped spark plugs

Use only iridium-tipped spark plugs. Do not adjust the spark plug gap.

Electrical system

Battery	
Specific gravity reading at 20°C (68°F):	1.25 or higher If the specific gravity is lower than the standard value, charge the battery.
Charging rates	
Quick charge	15 A max.
Slow charge	5 A max.

Automatic transmission

Fluid capacity*	Gasoline engine	8.5 L (9.0 qt., 7.5 Imp.qt.)
	Diesel engine	9.5 L (10.0 qt., 8.4 Imp.qt.)
Fluid type		Toyota Genuine ATF WS

*: The fluid capacity is the quantity of reference.
If replacement is necessary, contact your Toyota dealer.

NOTICE

■ Automatic transmission fluid type

Using transmission fluid other than the above type may cause abnormal noise or vibration, or damage the transmission of your vehicle.

Manual transmission

Oil capacity	5-speed models		2.6 L (2.7 qt., 2.3 Imp.qt.)
	6-speed models	4WD models	2.5 L (2.6 qt., 2.2 Imp.qt.)
		Pre Runner	2.7 L (2.9 qt., 2.4 Imp.qt.)
Oil type			TOYOTA Genuine Manual Transmission Gear Oil API GL-3 (GL-4) or equivalent
Recommended oil viscosity			SAE 75W-90

NOTICE

■ Manual transmission gear oil

Please be aware that depending on the particular characteristics of the gear oil used or the operating conditions, idle sound, shift feeling and/or fuel efficiency may be different or affected. Toyota recommends to use "TOYOTA Genuine Manual Transmission Gear Oil" to achieve optimal performance

Transfer (4WD models)

Oil capacity	1.0 L (1.1 qt., 0.9 Imp.qt.)
Oil type*	Toyota Genuine Transfer Gear oil LF or equivalent
Recommended oil viscosity	SAE 75W

*: Your Toyota vehicle is filled with “Toyota Genuine Transfer Gear oil LF” at the factory. Use Toyota approved “Toyota Genuine Transfer Gear oil LF” or an equivalent oil of matching quality that satisfies the above specifications. Please contact your Toyota dealer for further details.

Differential

Oil capacity	Front (4WD models)	1.60 L (1.69 qt., 1.41 Imp.qt.)	
	Rear	Without rear differential lock system	3.65 L (3.86 qt., 3.21 Imp.qt.)
		With rear differential lock system	3.60 L (3.80 qt., 3.17 Imp.qt.)
Oil type* and oil viscosity		Toyota Genuine Differential gear oil LT 75W-85 GL-5 or equivalent	

*: Your Toyota vehicle is filled with “Toyota Genuine Differential Gear Oil” at the factory. Use Toyota approved “Toyota Genuine Differential Gear Oil” or an equivalent oil of matching quality that satisfies the above specifications. Please contact your Toyota dealer for further details.

Clutch (vehicles with manual transmission)

Pedal free play	5 — 15 mm (0.2 — 0.6 in.)
Fluid type	SAE J1703 or FMVSS No.116 DOT 3 or SAE J1704 or FMVSS No.116 DOT 4

Brakes

Pedal clearance* ¹	2WD models	87 mm (3.4 in.)
	4WD models and Pre Runner	82 mm (3.2 in.)
Pedal free play		1.0 — 6.0 mm (0.04 — 0.24 in.)
Parking brake lever travel* ²		7 — 9 clicks
Fluid type		SAE J1703 or FMVSS No.116 DOT 3 or SAE J1704 or FMVSS No.116 DOT 4

*¹: Minimum pedal clearance when depressed with a force of 490 N (50 kgf, 110 lbf) while the engine is running.

*²: Parking brake lever travel when pulled up with a force of 200 N (20 kgf, 45 lbf)

Chassis lubrication

Propeller shafts	Front (4WD models)	Spider	Lithium base chassis grease, NLGI No.2
		Slide yoke	Molybdenum-disulfide lithium base chassis grease, NLGI No.2 or lithium base chassis grease, NLGI No.2
	Rear	Spider*	Lithium base chassis grease, NLGI No.2

*: With grease fitting only

Steering

Free play	Less than 30 mm (1.2 in.)
Power steering fluid type	Automatic transmission fluid DEXRON® II or III

Tires and wheels

► 16 inch tires

Tire size	215/65R16C 106/104S			
Tire inflation pressure (Recommended cold tire inflation pressure)	Front wheel kPa (kgf/cm ² or bar, psi)	Rear wheel (unladen) kPa (kgf/cm ² or bar, psi)	Rear wheel (full load) kPa (kgf/cm ² or bar, psi)	
	Single-cab models	240 (2.4, 35)	290 (2.9, 42)	370 (3.7, 54)
	Double-cab models	240 (2.4, 35)	290 (2.9, 42)	350 (3.5, 51)
Wheel size	16 × 6J			
Wheel nut torque	152 N•m (15.5 kgf•m, 112 ft•lbf)			

► 17 inch tires (type A)

Tire size	225/70R17C 108/106S		
Tire inflation pressure (Recommended cold tire inflation pressure)	Front wheel kPa (kgf/cm ² or bar, psi)	Rear wheel (unladen) kPa (kgf/cm ² or bar, psi)	Rear wheel (full load) kPa (kgf/cm ² or bar, psi)
	240 (2.4, 35)	240 (2.4, 35)	300 (3.0, 44)
Wheel size	17 × 6J		
Wheel nut torque	105 N•m (10.7 kgf•m, 77 ft•lbf)		

► 17 inch tires (type B)

Tire size	265/65R17 112S			
Tire inflation pressure (Recommended cold tire inflation pressure)	Front wheel (unladen) kPa (kgf/cm ² or bar, psi)	Front wheel (full load) kPa (kgf/cm ² or bar, psi)	Rear wheel (unladen) kPa (kgf/cm ² or bar, psi)	Rear wheel (full load) kPa (kgf/cm ² or bar, psi)
	200 (2.0, 29)	230 (2.3, 33)	200 (2.0, 29)	250 (2.5, 36)
Wheel size	17 × 7 1/2J			
Wheel nut torque	105 N•m (10.7 kgf•m, 77 ft•lbf)			

► 18 inch tires

Tire size	265/60R18 110H			
Tire inflation pressure (Recommended cold tire inflation pressure)	Front wheel (unladen) kPa (kgf/cm ² or bar, psi)	Front wheel (full load) kPa (kgf/cm ² or bar, psi)	Rear wheel (unladen) kPa (kgf/cm ² or bar, psi)	Rear wheel (full load) kPa (kgf/cm ² or bar, psi)
	200 (2.0, 29)	230 (2.3, 33)	200 (2.0, 29)	250 (2.5, 36)
Wheel size	18 × 7 1/2J			
Wheel nut torque	105 N•m (10.7 kgf•m, 77 ft•lbf)			

Light bulbs

	Light bulbs	W	Type
Exterior	Headlights High/low beams (halogen headlights type A)	60/55	A
	Low beams (halogen headlights type B)	55	B
	High beams (halogen headlights type B)	60	C
	Halogen fog lights*	19	D
	Front position lights/daytime running lights (halogen headlights)	21/5	E
	Front turn signal lights (halogen headlights type A)	21	F
	Front turn signal lights (halogen headlights type B)	21	G
	Rear turn signal lights	21	F
	Back-up lights (without LED stop lights)	21	H
	Stop/tail lights (without LED stop lights)	21/5	H
Interior	License plate light	5	E
	Outer foot lights*	5	E
	Interior light*	8	I
	Personal/interior lights	5	E

A: H4 halogen bulbs

B: H11 halogen bulbs

C: HB3 halogen bulbs

D: H16 halogen bulbs

E: Wedge base bulbs (clear)

*: If equipped

F: Single end bulbs (amber)

G: Wedge base bulbs (amber)

H: Single end bulbs (clear)

I: Double end bulbs

Fuel information

◆ Gasoline engine

You must only use unleaded gasoline.

Select unleaded gasoline with a Research Octane Number of 91 or higher for optimum engine performance.

◆ Diesel engine

You must use only diesel fuel that contains 10 ppm or less of sulfur with a cetane number of 48 or higher.

■ Use of ethanol blended gasoline in a gasoline engine

Toyota allows the use of ethanol blended gasoline where the ethanol content is up to 10%. Make sure that the ethanol blended gasoline to be used has a Research Octane Number that follows the above.

■ If you plan to drive in foreign countries (diesel engine)

Low sulfur diesel fuel may not be available, so please check the availability with your distributor.

■ If your engine knocks

- Consult your Toyota dealer.
- You may occasionally notice light knocking for a short time while accelerating or driving uphill. This is normal and there is no need for concern.

**NOTICE****■ Notice on gasoline fuel quality**

- Do not use improper fuels. If improper fuels are used, the engine will be damaged.
- Do not use gasoline with metallic additives, for example manganese, iron or lead, otherwise it may cause damage on your engine or emission control system.
- Do not add aftermarket fuel additives which contain metallic additives.
- Do not use the methanol blended gasoline such as M15, M85, M100. The use of gasoline containing methanol may cause engine damage or failure.

■ Notice on diesel fuel quality

- Do not use improper fuels. If improper fuels are used, the engine will be damaged.
- Do not use a fuel that contains more than 10 ppm of sulfur. Use of such a high sulfur fuel may damage the engine.
- FAME (Fatty Acid Methyl Ester) fuel sold under names such as “B30” or “B100” and fuel containing a large amount of FAME should not be used. Your vehicle can use diesel mixed with 5% max biodiesel FAME (B5). The use of fuel with more than 5% FAME content (B5) will damage the vehicle’s fuel system. You must ensure that refueling is carried out only from a source where fuel specification and quality can be guaranteed. In case of any doubt, ask your Toyota dealer.





Customizable features

Your vehicle includes a variety of electronic features that can be personalized to your preferences. The settings of these features can be changed using the multi-information display, navigation system, multimedia system or at your Toyota dealer.

Some function settings are changed simultaneously with other functions being customized. Contact your Toyota dealer for further details.

Customizing vehicle features

■ Changing using the multi-information display

- 1 Use the meter control switches to select  while the vehicle is stopped, and then press  to display the customize mode screen.
- 2 Select the desired item, and then press .
- 3 Select the desired setting, and then press .

To go back to the previous screen or exit the customize mode, press .

■ Changing using the navigation system or multimedia system



- 1 Press the “MENU” button while the vehicle is stopped.
- 2 Select “Setup”.
- 3 Select “Vehicle”.
- 4 Select “TOYOTA park assist”.

Customizable features

- ① Settings that can be changed using navigation system or multimedia system
- ② Settings that can be changed using the multi-information display
- ③ Settings that can be changed by your Toyota dealer

Definition of symbols: O = Available, – = Not available

■ **Gauges, meters and multi-information display (→P. 92)**

Function *1		Default setting	Customized setting	①	②	③
Units		km (L/100 km)	km (km/L)	–	O	–
Eco Driving Indicator Light		On (Self-lighting)	Off	–	O	–
 switch settings		Drive information 1	Desired status screen *2	–	O	–
Drive information 1	Current fuel economy	Average fuel economy	*3	–	O	–
	Average fuel economy			–	O	–
Drive information 2	Distance to empty	Average speed	*3	–	O	–
	Average speed			–	O	–
Pop-up display		On	Off	–	O	–
Accent color		Color 1	Color 1 to color 4	–	O	–
Eco Saving	Fuel consumption comparison	10.0	*4	–	O	–
	Fuel price	150	*4	–	O	–
	Currency	 (No currency unit)	 (Dollar)	–	O	–

- *1: For details about each function: →P. 92
- *2: Some status screens cannot be registered (indicated on multi-information display).
- *3: Customized items are the following items except for default setting items: current fuel economy (bar type), current fuel economy (value type), average fuel economy (after reset), average fuel economy (after start), average fuel economy (after refuel), average speed (after reset), average speed (after start), elapsed time (after reset), elapsed time (after start), distance (range), distance (after start), blank.
- *4: The values can be changed using the meter control switches.

■ PCS (Pre-Collision System) (→P. 220)

Function	Default setting	Customized setting	①	②	③
PCS (Pre-Collision System)	On	Off	–	○	–
Sensitivity (adjust alert timing)	Middle	Early	–	○	–
		Late	–	○	–

■ LDA (Lane Departure Alert With Yaw Assist Function) (→P. 231)

Function	Default setting	Customized setting	①	②	③
Yaw Assist	On	Off	–	○	–
Warning sensitivity	Standard	High	–	○	–
Vehicle sway warning function	On	Off	–	○	–
Vehicle sway warning sensitivity	Standard	Low	–	○	–
		High	–	○	–

■ RSA (Road Sign Assist) (→P. 242)

Function		Default setting	Customized setting	①	②	③
RSA (Road Sign Assist)*		On	Off	–	○	–
Notification method	Excess speed	Display only	No notification	–	○	–
			Display and buzzer	–	○	–
Excess speed notification level		1 km/h (1 mph)	3 km/h (2 mph)	–	○	–
			5 km/h (3 mph)	–	○	–

*: RSA function becomes On when the engine switch is turned to the “ON” position (vehicles without smart entry & start system) or IGNITION ON mode (vehicles with smart entry & start system)

■ Dynamic Radar Cruise Control with Road Sign Assist (→P. 257)

Function		Default setting	Customized setting	①	②	③
Dynamic Radar Cruise Control with Road Sign Assist		On	Off	–	○	–

■ Toyota parking assist-sensor* (→P. 262)

Function		Default setting	Customized setting	①	②	③
Detection distance of the rear center sensor		Long	Short	○	–	○
Buzzer volume		Level 2	Level 1 to 3	○	–	○

*: If equipped

■ Smart entry & start system* (→P. 120)

Function	Default setting	Customized setting	①	②	③
Smart entry & start system	On	Off	–	–	○
Operational signal (buzzer)*	Level 7	Off	–	–	○
		Level 1 to 6			

*: If equipped

■ Automatic light control system (→P. 200)

Function	Default setting	Customized setting	①	②	③
Light sensor sensitivity	Standard	-2 to 2	–	–	○

■ Turn signal lever (→P. 198)

Function	Default setting	Customized setting	①	②	③
Times of flashing of the lane change signal flashers	3	4	–	–	○
		5			
		6			
		7			
		Off			

WARNING

■ During customization

As the engine needs to be running during customization, ensure that the vehicle is parked in a place with adequate ventilation. In a closed area such as a garage, exhaust gases including harmful carbon monoxide (CO) may collect and enter the vehicle. This may lead to death or a serious health hazard.

NOTICE

■ During customization

To prevent battery discharge, ensure that the engine is running while customizing features.

Index

What to do if... (Troubleshooting)	490
Alphabetical index	494

Refer to the “Navigation and Multimedia System Owner’s Manual” or “Multimedia Owner’s Manual” for information regarding the equipment listed below.

- Navigation system
- Audio system
- Rear view monitor system

What to do if... (Troubleshooting)

If you have a problem, check the following before contacting your Toyota dealer.

The doors cannot be locked, unlocked, opened or closed



You lose your keys

- If you lose your keys or mechanical keys, new genuine keys or mechanical keys can be made by your Toyota dealer. (→P. 109)
- Vehicles with smart entry & start system:
If you lose your electronic keys, the risk of vehicle theft increases significantly. Contact your Toyota dealer immediately. (→P. 110)



The doors cannot be locked or unlocked

- Is the key battery weak or depleted? (→P. 373)
- Vehicles with smart entry & start system:
Is the engine switch in IGNITION ON mode?
When locking the doors, turn the engine switch off. (→P. 179)
- Vehicles with smart entry & start system:
Is the electronic key left inside the vehicle?
When locking the doors, make sure that you have the electronic key on your person.
- The function may not operate properly due to the condition of the radio wave. (→P. 115, 123)



The rear door cannot be opened (vehicles with rear door child-protector lock)

- Is the rear door child-protector lock set?
The rear door cannot be opened from inside the vehicle when the lock is set. Open the rear door from outside and then unlock the rear door child-protector lock. (→P. 114)

If you think something is wrong



The engine does not start (vehicles without smart entry & start system)

- Vehicles with manual transmission:
Do you turn the key with the clutch pedal depressed firmly? (→P. 173)
- Vehicles with automatic transmission:
Is the shift lever in P? (→P. 173)
- Is the steering wheel unlocked? (→P. 175)
- Is the battery discharged? (→P. 454)



The engine does not start (vehicles with smart entry & start system)

- Did you press the engine switch while firmly depressing the brake pedal?
(→P. 176)
- Vehicles with automatic transmission:
Is the shift lever in P? (→P. 176)
- Is the electronic key anywhere detectable inside the vehicle? (→P. 121)
- Is the steering wheel unlocked? (→P. 181)
- Is the electronic key battery weak or depleted?
In this case, the engine can be started in a temporary way. (→P. 451)
- Is the battery discharged? (→P. 454)



The shift lever cannot be shifted from P even if you depress the brake pedal (vehicles with automatic transmission)

- Vehicles without smart entry & start system:
Is the engine switch in the "ON" position?
If you cannot release the shift lever by depressing the brake pedal with the engine switch in the "ON" position: →P. 189
- Vehicles with smart entry & start system:
Is the engine switch in IGNITION ON mode?
If you cannot release the shift lever by depressing the brake pedal with the engine switch in IGNITION ON mode: →P. 189



The steering wheel cannot be turned after the engine is stopped

- Vehicles without smart entry & start system:
It is locked to prevent theft of the vehicle if the key is removed from the engine switch. (→P. 175)
- Vehicles with smart entry & start system:
It is locked automatically to prevent theft of the vehicle. (→P. 181)



The windows do not open or close by operating the power window switches

- Is the window lock switch pressed?
The power window except for the one at the driver's seat cannot be operated if the window lock switch is pressed. (→P. 143)



The engine switch is turned off automatically (vehicles with smart entry & start system)

- The auto power off function will be operated if the vehicle is left in ACCESSORY or IGNITION ON mode (the engine is not operating) for a period of time. (→P. 180)



A warning buzzer sounds during driving

- The seat belt reminder light is flashing
Are the driver and passengers wearing the seat belts? (→P. 423)
- The parking brake indicator light is on
Is the parking brake released? (→P. 199)

Depending on the situation, other types of warning buzzer may also sound. (→P. 421, 426)



An alarm is activated and the horn sounds

- Did anyone inside the vehicle open a door during setting the alarm?
The sensor detects it and the alarm sounds. (→P. 79)

To stop the alarm, turn the engine switch to the "ON" position (vehicles without smart entry & start system) or IGNITION ON mode (vehicles with smart entry & start system) or start the engine.



A warning buzzer sounds when leaving the vehicle (vehicles with smart entry & start system)

- Is the message displayed on the multi-information display?
Check the message on the multi-information display.



A warning light turns on or a warning message is displayed

- When a warning light turns on or a warning message is displayed, refer to P. 421, 426.

When a problem has occurred



If you have a flat tire

- Stop the vehicle in a safe place and replace the flat tire with the spare tire.
(→P. 431)



The vehicle becomes stuck

- Try the procedure for when the vehicle becomes stuck in mud, dirt, or snow. (→P. 463)

Alphabetical index

A

- A/C**..... **306, 311**
 Air conditioning filter..... 371
 Automatic air conditioning
 system 311
 Manual air conditioning
 system 306
- ABS (Anti-lock Brake System)** **284**
 Function 284
 Warning light 422
- Access panels**..... **116**
- Air conditioning filter** **371**
- Air conditioning**
system **306, 311**
 Air conditioning filter..... 371
 Automatic air conditioning
 system 311
 Manual air conditioning
 system 306
- Airbags** **35**
 Airbag operating
 conditions 41
 Airbag precautions for
 your child 37
 Airbag warning light 421
 Correct driving posture..... 28
 Curtain shield airbag
 operating conditions 41
 Curtain shield airbag
 precautions 39
 Front passenger occupant
 classification system..... 46
 General airbag
 precautions 37
- Locations of airbags..... 35
 Modification and
 disposal of airbags 40
 Side airbag operating
 conditions 41
 Side airbag precautions 39
 Side and curtain shield
 airbags operating
 conditions 41
 Side and curtain shield
 airbags precautions 39
 SRS airbags..... 35
- Alarm** **79**
- Antennas (smart entry & start system)**..... **120**
- Anti-lock brake system (ABS)** **284**
 Function 284
 Warning light..... 422
- Armrest**..... **336**
- AUTO LSD** **294**
- Automatic air conditioning system**
 Air conditioning filter 371
 Automatic air conditioning
 system 311
- Automatic disconnecting differential**..... **270**
- Automatic light control system**..... **202**
- Automatic transmission**..... **184**
 If the shift lever cannot be
 shifted from P 189
- Auxiliary boxes** **327**

B**Back-up lights**

Replacing light bulbs..... 398, 405

Wattage..... 480

Battery

Battery checking 358

If the vehicle battery is
discharged 454

Preparing and checking
before winter..... 301

Bottle holders..... 326

Brake

Fluid 477

Parking brake 199

Warning light 421

Brake assist..... 284

Break-in tips 152

Brightness control

Instrument panel light
control..... 90

C**Care**

Exterior 338

Interior..... 342

Seat belts..... 343

Wheels..... 339

Chains..... 302

Child restraint system..... 52

Child restraint system
installation method 69

Fixed with a seat belt 70

Fixed with an ISOFIX
rigid anchor..... 72

Points to remember 52

Riding with children..... 51

Using a child restraint
anchor fitting..... 74

Child safety 51

Airbag precautions 37

Battery precautions..... 361, 458

Child restraint system 52

How your child should
wear the seat belt..... 32

Installing child restraints ... 70, 73

Power window lock
switch 143

Power window precautions... 145

Rear door child-protectors ... 114

Removed key battery
precautions..... 375

Seat belt precautions 34

Seat heater precautions..... 319

Child-protectors	114
Cleaning	338, 342
Exterior.....	338
Interior.....	342
Seat belts.....	343
Wheels.....	339
Clock	332
Clutch	476
Coat hooks	335
Condenser	358
Console box	324
Cooling system	
Engine overheating.....	459
Cruise control	
Dynamic radar cruise control.....	246
Cup holders	325
Curtain shield airbags	35

D

DAC	291
Daytime running light system	202
Deck hooks	330
Defogger	
Outside rear view mirrors.....	313
Rear window.....	307
Windshield.....	307, 313
Differential	
Oil.....	476
Dimension	466

Display

Dynamic radar cruise control.....	246
LDA (Lane Departure Alert with Yaw Assist Function).....	237
Multi-information display.....	92
Trip information.....	94
Do-it-yourself maintenance	347
Doors	
Door glasses.....	142
Door lock.....	111
Outside rear view mirrors.....	139
Rear door child-protectors	114
Side doors.....	111
Downhill assist control system	291
DPF (Diesel Particulate Filter) system	
Warning messages.....	429
Driver's seat belt reminder light	423
Drive-start control	151
Driving	
Break-in tips.....	152
Correct posture.....	28
Procedures.....	148
Winter drive tips.....	301
Dynamic radar cruise control	246
Function.....	246
Warning message.....	429

E

Eco Driving Indicator..... 85, 87

EDR (Event data recorder)..... 10

Electronic key

- If the electronic key does not operate properly 450
- Replacing the battery 373

Emergency flashers..... 410

Emergency, in case of

- If a warning buzzer sounds 421
- If a warning light turns on 421
- If the electronic key does not operate properly 450
- If the engine will not start 448
- If the vehicle battery is discharged 454
- If you have a flat tire 431
- If you lose your keys 109
- If you run out of fuel and the engine stalls 462
- If you think something is wrong 419
- If your vehicle becomes stuck 463
- If your vehicle has to be stopped in an emergency 411
- If your vehicle needs to be towed 413
- If your vehicle overheats 459

Engine

- “ACC” position 174
- Compartment 351
- Engine switch 173, 176
- Hood 349
- How to start the engine 173, 176
- Identification number 468
- If the engine will not start 448
- If you run out of fuel and the engine stalls 462
- If your vehicle has to be stopped in an emergency 411
- Ignition switch (engine switch) 173, 176
- Overheating 459

Engine coolant

- Capacity 474
- Checking 356
- Preparing and checking before winter 301

Engine coolant

temperature gauge..... 90

Engine immobilizer system 77

Engine oil

- Capacity 471
- Checking 353
- Preparing and checking before winter 301

Engine switch

(ignition switch)..... 173, 176

- Auto power off function 180
- Changing the engine switch modes 179
- Changing the engine switch position 174
- If your vehicle has to be stopped in an emergency 411
- Starting the engine 173, 176

Engine switch light (ignition switch light)	320
Event data recorder (EDR)	10

F

Flat tire	431
Floor mat	26
Fluid	
Automatic transmission	475
Brake	477
Clutch	476
Steering	477
Transfer	476
Washer	362
Four-wheel drive system	
Front-wheel drive control switch	270
Fog lights	
Replacing light bulbs	395, 405
Switch	204
Wattage	480
Front passenger occupant classification system	46
Front position lights	
Light switch	200
Replacing light bulbs	389, 390, 405
Wattage	480
Front seats	
Adjustment	127
Cleaning	342
Correct driving posture	28
Head restraints	132
Seat heaters	319
Front turn signal lights	
Replacing light bulbs	392, 393, 405
Turn signal lever	198
Wattage	480

Fuel

Capacity	470
Fuel filter	363
Fuel gauge	89
Fuel pump shut off system	420
If you run out of fuel and the engine stalls	462
Information	481
Refueling	208
Type	470
Fuel consumption information	101
Fuel filler door	208
Refueling	208
Fuel filter	363
Fuel pump shut off system	420
Fuses	376

G

Gauges	89
Glove box	324
Grocery bag hooks	335

H

Head restraints	132
Headlights	200
Light switch	200
Replacing light bulbs	384, 385, 387, 405
Wattage	480
Heaters	
Automatic air conditioning system	311
Manual air conditioning system	306
Seat heaters	319

High mounted stoplight	
Replacing	405
Hill-start assist control	284
Hood	349
Hooks	
Coat hooks.....	335
Grocery bag hooks.....	335
Retaining hooks (floor mat).....	26
Horn	136

I

Identification	
Engine.....	468
Vehicle	468
Ignition switch (engine switch)	173, 176
Auto power off function	180
Changing the engine switch modes.....	179
Changing the engine switch position	174
If your vehicle has to be stopped in an emergency.....	411
Starting the engine.....	173, 176
Ignition switch light (engine switch light)	320
Illuminated entry system	322
Immobilizer system	77
Indicators	82
Inside rear view mirror	137
Instrument panel light control	90
Intercooler	358
Interior lights	320
Switch	321
Wattage.....	480

J

Jack	
Vehicle-equipped jack.....	432
Jack handle	437
Jam protection function	
Power windows.....	143

K

Keyless entry	
Smart entry & start system ...	111
Wireless remote control	107
Keys	106
Electronic key	106
Engine switch.....	173
If the electronic key does not operate properly	450
If you lose your keys	109
Key number plate.....	106
Keyless entry	107
Keys.....	106
Replacing the battery.....	373
Wireless remote control key	107

L

LDA (Lane Departure Alert With Yaw Assist Function) ...	231
Warning message.....	241
Lever	
Auxiliary catch lever.....	349
Hood lock release lever	349
Shift lever.....	184, 191
Turn signal lever	198
Wiper lever.....	205
License plate light	
Light switch	200
Replacing light bulb	400
Wattage	480

Light

Engine switch light	320
Fog light switch	204
Headlight switch	200
Illuminated entry system	322
Interior lights	321
Interior light list	320
Outer foot lights	320
Personal light	321
Replacing light bulbs	381
Turn signal lever	198
Wattage	480

Light bulbs

Replacing	381
Wattage	480

Lock steering column..... 175, 181**M****Maintenance**

Do-it-yourself maintenance ...	347
Maintenance data	466
Maintenance requirements ...	345

Malfunction indicator lamp 421**Manual headlight leveling**

dial	201
------------	-----

Manual transmission 191**Master warning light..... 423****Meter**

Indicators	82
Instrument panel light control	90
Meters	89
Multi-information display	92
Warning lights	421

Mirrors

Inside rear view mirror	137
Outside rear view mirror defoggers.....	313
Outside rear view mirrors.....	139
Vanity mirror.....	331

Multi-information display

Drive information.....	94
Dynamic radar cruise control.....	246
Language.....	484
LDA (Lane Departure Alert with Yaw Assist Function)	237
PCS (Pre-Collision System)	221
Trip information.....	94

Multimedia system***N****Navigation system*****O****Odometer..... 89****Oil**

Differential oil	476
Engine oil.....	471
Manual transmission oil	475
Transfer oil.....	476

Opener

Fuel filler door	208
Hood	349

Outer foot lights

Location	320
Replacing light bulbs.....	401
Wattage	480

Outside rear view mirrors 139

Adjusting and folding	139
Outside rear view mirror defoggers	313

Outside temperature**display..... 89****Overhead console 327****Overheating, Engine..... 459**

P

Parking assist sensor (Toyota parking assist-sensor)	262
Parking brake	
Operation	199
Parking brake engaged warning buzzer	421
PCS (Pre-Collision System)	220
Enabling/disabling the system	224
Function	221
Warning light	423
Warning message	429
Personal light	321
Switch	321
Wattage	480
Power outlets	333
Power steering	
Fluid	477
Warning light	422
Power windows	
Jam protection function	143
Operation	142
Window lock switch	143
Pre-Collision System (PCS)	220
Enabling/disabling the system	224
Function	221
Warning light	423
Warning message	429

Q

Quarter windows	146
------------------------------	------------

R

Radar cruise control (dynamic radar cruise control)	246
Radiator	358
Rear differential lock system	280
Rear passengers' seat belt reminder light	423
Rear seat	
Raising the bottom cushion	129
Rear step bumper	118
Rear turn signal lights	
Replacing light bulbs	398, 399
Turn signal lever	198
Wattage	480
Rear view mirror	
Inside rear view mirror	137
Outside rear view mirrors	139
Rear window defogger	307, 313
Refueling	208
Capacity	470
Fuel types	470
Opening the fuel tank cap	208
Replacing	
Electronic key battery	373
Fuses	376
Light bulbs	381
Tires	431
Wireless remote control battery	373
Road Sign Assist	242
RSA (Road Sign Assist)	242

*: Refer to "Navigation and Multimedia System Owner's Manual" or "Multimedia Owner's Manual".

S

Seat belts	30
Adjusting the seat belt.....	31
Child restraint system installation.....	52
Cleaning and maintaining the seat belt.....	343
Emergency Locking Retractor.....	32
How to wear your seat belt	30
How your child should wear the seat belt	32
Pregnant women, proper seat belt use	33
Reminder light and buzzer.....	423
Seat belt pretensioners	31
SRS warning light	421
Seat heaters.....	319
Seats	
Adjustment.....	127
Adjustment precautions	128
Child seats/child restraint system installation	52
Cleaning.....	342
Head restraint	132
Properly sitting in the seat.....	28
Raising the bottom cushion	129
Seat heaters	319
Sensor	
Automatic headlight system	202
LDA (Lane Departure Alert with Yaw Assist Function).....	231
Toyota parking assist-sensor	262
Toyota safety sense.....	214

Service reminder indicators	82
Shift lever	
Automatic transmission.....	184
Front-wheel drive control switch	270
If the shift lever cannot be shifted from P	189
Manual transmission.....	191
Shift lock system	188
Side airbags	35
Side doors	111
Side mirrors	139
Adjusting and folding	139
Side turn signal lights	
Replacing light bulbs.....	405
Turn signal lever	198
Smart entry & start system	120
Antenna location	120
Entry functions	111
Starting the engine.....	176
Warning message.....	426
Snow tires	301
Spare tire	
Inflation pressure	478
Storage location.....	431
Spark plug	474
Specifications	466
Speedometer	89
Steering	
Column lock release	175, 181
Fluid	477
Steering wheel	
Adjustment.....	135
Audio switches*	
Meter control switches	93
Telephone switches*	
Stop lights	
Replacing light bulbs.....	398, 405
Wattage	480

Storage feature 323

Storage precautions 323

Stuck

 If your vehicle becomes stuck 463

Sun visors 331

Switch

 Audio remote control switches * 246

 Cruise control switch 246

 Door lock switch 113

 Driving mode select switches 186, 192

 Emergency flashers switch ... 410

 Engine switch 173, 176

 Fog light switch 204

 Front-wheel drive control switch 270

 Heater idle up switch 308, 314

 Ignition switch 173, 176

 LDA (Lane Departure Alert with Yaw Assist Function) 237

 Light switches 200

 Meter control switches 93

 Outside rear view mirror defoggers switch 313

 Outside rear view mirror switches 139

 Power door lock switch 113

 Power window switch 142

 Rear window defogger switch 307

 Seat heater switches 319

 Toyota parking assist-sensor 263

 VSC OFF switch 286

 Window lock switch 143

 Windshield wipers and washer switch 205

T

Tachometer 89

Tailgate 117

Tail lights

 Light switch 200

 Replacing light bulbs 398, 405

 Wattage 480

Talk switch*

Telephone switches*

Theft deterrent system

 Alarm 79

 Engine immobilizer system 77

Tire inflation pressure

 Maintenance data 478

Tires 364

 Chains 302

 Checking 364

 If you have a flat tire 431

 Inflation pressure 367, 478

 Replacing 431

 Rotating tires 365

 Size 478

 Snow tires 301

 Spare tire 431

Tools 434

Towing

 Emergency towing 413

 Towing hook 416

 Trailer towing 162

Toyota parking assist-sensor 262

Toyota Safety Sense 213

Traction control 284

Trailer towing 162

Transmission

 Automatic transmission 184

 If the shift lever cannot be shifted from P 189

 Manual transmission 191

*: Refer to “Navigation and Multimedia System Owner’s Manual” or “Multimedia Owner’s Manual”.

TRC (Traction Control)	284
Trip information	94
Trip meters	89
Turn signal lights	
Replacing light	
bulbs	392, 398, 405
Turn signal lever	198
Wattage.....	480

U

Upper anchorage strap	74
USB port*	

V

Valet key	106
Vanity mirror	331
Vehicle data recording	9
Vehicle identification	
number	468
Vehicle Stability Control	
(VSC).....	284
VSC (Vehicle Stability	
Control)	284

W

Warning buzzers

Key reminder	175
Pre-collision braking	221
Seat belt reminder	423
Toyota parking	
assist-sensor	265

Warning lights

ABS.....	422
AUTO LSD.....	424
Brake system.....	421
Electronic engine control	
system.....	421
LDA (Lane Departure	
Alert with Yaw Assist	
Function)	423
Low fuel level.....	423
Malfunction indicator lamp	421
Master warning light	423
Parking brake	424
PCS (Pre-Collision	
System)	423
Power steering.....	422
Seat belt reminder	
light.....	423
Slip indicator	422
SRS	421

Washer	
Checking	362
Preparing and checking	
before winter	301
Switch	205
Washing and waxing	338
Wheels	369
Replacing wheels	431
Size	478
Window glasses	142
Window lock switch	143
Windows	
Power windows	142
Rear window	
defogger	307, 313
Washer	205
Windshield wipers	
Intermittent windshield	
wipers	205
Winter driving tips	301
Wireless remote control	
key	107
Locking/Unlocking	107
Replacing the battery	373

*: Refer to “Navigation and Multimedia System Owner’s Manual” or
“Multimedia Owner’s Manual”.

GAS STATION INFORMATION

Auxiliary catch lever

P. 349

Fuel filler door*

P. 210

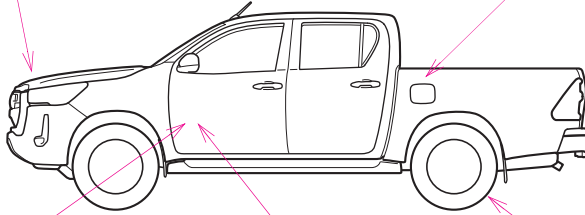

IIPPK158

Hood lock release lever

P. 349

Fuel filler door opener*

P. 210

Tire inflation pressure

P. 478

Fuel tank capacity (Reference)		80 L (21.1 gal., 17.6 Imp.gal.)	
Fuel type	Gasoline engine	Unleaded gasoline only	P. 470
	Diesel engine	Diesel fuel that contains 10 ppm or less of sulfur	P. 470
Cold tire inflation pressure		P. 478	
Engine oil capacity (Drain and refill — reference)		P. 471	
Engine oil type		P. 471	

*: If equipped

J Q-1



Publication No. OM0K408E
Part No. 01999-0K408
Printed in Thailand 01-2005-00
ハイラックス (豪州E)