

Owner's Manual

For your safety and comfort, read carefully and keep in the vehicle.

CAMRY **HYBRID**

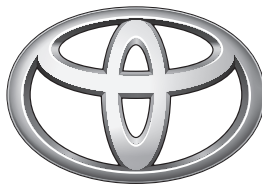

TOYOTA

Service Station Information

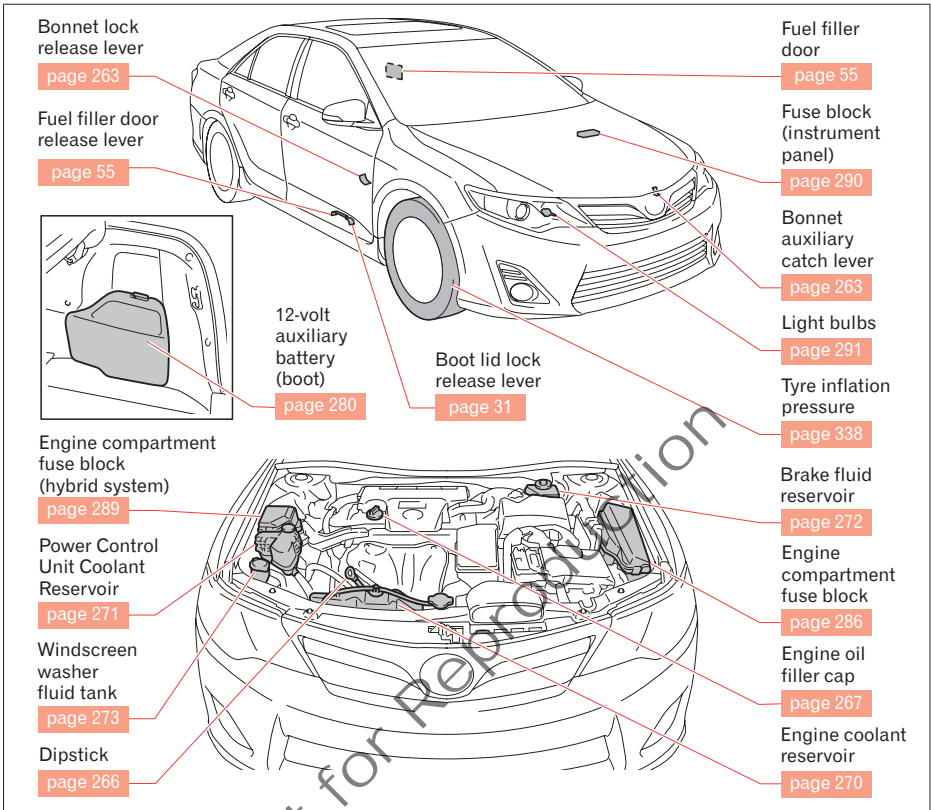

Fuel tank capacity (reference)	65 litres
Fuel type	Unleaded petrol, Research Octane Number 91 or higher (Unleaded petrol containing up to 10% ethanol can be safely used)
Cold tyre inflation pressure	Refer to "Tyres and wheels" on page 338.
Engine oil capacity (drain and refill)	With oil filter 4.4 Litres Without oil filter 4.0 Litres
Engine oil type	Toyota Genuine Motor Oil or equivalent Refer to "Checking the engine oil level" on page 266 Oil grade: 0W-20, 5W-20, 5W-30 and 10W-30: API grade SL, SM, SN or ILSAC multigrade engine oil 15W-40 and 20W-50: API grade SL, SM or SN multigrade engine oil
Fuse location	Refer to "Checking and replacing fuses" on page 283
Light bulbs	Refer to "Light bulbs" on page 291

Table of contents Table of contents (iii), Pictorial Index (vi), For your information (xiv)	iii
Before driving Operating features such as the hybrid system, door locks, steering column and mirrors.	1
When driving Starting, stopping and driving related information.	77
Interior features Air conditioning, audio system and other useful features.	159
Maintenance and care Cleaning, maintenance requirements and do-it-yourself maintenance.	253
When trouble arises What to do if the vehicle needs to be towed, has a flat tyre or is involved in an accident.	305
Vehicle specifications Detailed vehicle information.	331
Alphabetical index Alphabetical listing of information contained in this manual.	345
What to do if... / Service Station Information	354

Not for Reproduction

Pictorial Index - Exterior vi

Pictorial Index - Interior viii

 INSTRUMENT PANEL INDICATOR

 SYMBOLS xiv

For your information xvi

 IMPORTANT INFORMATION xvi

 SYMBOLS USED THROUGHOUT THIS MANUAL xvi

 SAFETY SYMBOL xvi

 ARROWS INDICATING OPERATIONS xvii

 OWNER'S MANUAL xvii

 ABBREVIATIONS xvii

 ACCESSORIES, SPARE PARTS AND MODIFICATION OF YOUR TOYOTA xviii

 INSTALLATION OF A MOBILE TWO-WAY RADIO SYSTEM xviii

 HYBRID BATTERY xviii

 DISPOSING OF YOUR TOYOTA xviii

 HIGH VOLTAGE CAUTIONS xix

 ROAD ACCIDENT CAUTIONS xx

 SMART ENTRY AND START SYSTEM xx

 TOYOTA AND PRIVACY xx

 VEHICLE CONTROL AND OPERATION DATA RECORDING xxix

BEFORE DRIVING 1

Toyota hybrid system 2

 HYBRID SYSTEM OVERVIEW 2

 HYBRID SYSTEM PRECAUTIONS 5

 ENERGY MONITOR / CONSUMPTION SCREEN 8

Key information 15

 KEYS 15

Opening, closing and locking the doors . 17

 WIRELESS REMOTE CONTROL 17

 SMART ENTRY AND START SYSTEM 19

 DOORS 28

 BOOT LID 31

Adjustable components 33

 SEATS 33

 FRONT SEATS 33

 FRONT HEAD RESTRAINTS 36

 DRIVING POSITION MEMORY SYSTEM 38

 REAR SEATS 40

 SEATBELTS 41

 TILT AND TELESCOPIC STEERING WHEEL 46

 ANTI-GLARE INSIDE REAR VIEW MIRROR 47

 AUTO ANTI-GLARE INSIDE REAR VIEW MIRROR 47

 OUTSIDE REAR VIEW MIRRORS 48

Opening and closing the windows and moon roof 50

 POWER WINDOWS 50

 MOON ROOF 52

Refuelling 55

 FUEL TANK CAP 55

Theft deterrent system 57

 ENGINE IMMOBILISER SYSTEM 57

 ALARM 58

Safety information 60

 SRS COMPONENTS 60

 SEATBELT PRETENSIONERS 60

 SRS AIRBAGS 62

 SRS AIRBAG PRECAUTIONS 67

 CHILD RESTRAINT 73

 CHILD RESTRAINT SYSTEM 74

 FLOOR MAT 76

WHEN DRIVING 77

Driving procedures 78

 POWER (IGNITION) SWITCH 78

 BEFORE STARTING THE HYBRID SYSTEM . . 79

 STARTING THE HYBRID SYSTEM 79

 EV DRIVE MODE 83

 DRIVING AND PARKING USING SMART ENTRY AND START SYSTEM 85

 HYBRID TRANSMISSION 86

 TURN SIGNAL LEVER 89

 PARKING BRAKE 90

 HORN 90

Instrument cluster 91

 GAUGES AND METERS 91

 INDICATORS AND WARNING LIGHTS 95

 MULTI-INFORMATION DISPLAY 100

Table of contents

Operating the lights and wipers	116
HEADLIGHT SWITCH	116
AUTOMATIC HIGH BEAM	118
FRONT FOG LIGHTS	122
WINDSCREEN WIPERS AND WASHERS	122
Using other driving systems	126
CRUISE CONTROL	126
REAR VIEW MONITOR SYSTEM	128
TOYOTA PARKING ASSIST-SENSOR	133
BLIND SPOT MONITOR (BSM)	136
DRIVING ASSIST SYSTEMS	140
Driving Information	144
RUNNING-IN PERIOD	144
PRE-TRIP SAFETY CHECK	144
INFORMATION WHEN DRIVING IN VARIOUS CONDITIONS	145
WINTER DRIVING TIPS	150
INSTALLING SNOW TYRES AND CHAINS	151
TRAILER TOWING	152
CARGO AND LUGGAGE	157
INTERIOR FEATURES 159	
Using the air conditioning system and defogger	161
AUTOMATIC AIR CONDITIONING SYSTEM	161
FRONT, SIDE AND REAR VENTS	168
REAR WINDOW DEFOGGER	169
Touch-screen audio system	170
QUICK REFERENCE	170
SETUP MENU	171
VEHICLE INFORMATION	174
AUDIO SYSTEM	176
USING THE RADIO	179
USING THE CD PLAYER	181
PLAYING AN AUDIO CD AND MP3 / WMA DISCS	181
LISTENING TO AN iPod®	189
LISTENING TO A USB MEMORY	194
USING THE AUX PORT	200
LISTENING TO BLUETOOTH® AUDIO	201
OPTIMAL USE OF THE AUDIO SYSTEM	208
USING THE STEERING WHEEL AUDIO SWITCHES	209
HANDS-FREE SYSTEM (FOR MOBILE PHONES)	211
USING THE BLUETOOTH® PHONE	215
SETTING THE HANDS-FREE SYSTEM	224
BLUETOOTH® SETTINGS	233
Using the interior lights	238
INTERIOR LIGHTS OVERVIEW	238
INTERIOR LIGHTS	238
PERSONAL LIGHTS	239
ILLUMINATED ENTRY SYSTEM	240
Using the storage features	241
STORAGE FEATURES OVERVIEW	241
GLOVE BOX	242
AUXILIARY BOXES	242
REAR CONSOLE BOX	243
CUP HOLDERS	244
BOTTLE HOLDERS	245
GROCERY BAG HOOKS	246
Other interior features	247
CLOCK	247
POWER OUTLETS	247
SUN VISORS	248
VANITY MIRRORS	249
REAR ELECTRIC SUNSHADE	249
FLOOR MAT	250
ASSIST GRIPS	251
COAT HOOKS	252
MAINTENANCE AND CARE 253	
Maintenance and care	254
CLEANING AND PROTECTING THE EXTERIOR	254
CLEANING AND PROTECTING THE INTERIOR	257
Maintenance requirements	259
MAINTENANCE REQUIREMENTS	259
DOES YOUR VEHICLE NEED REPAIRING?	260
Do-it-yourself maintenance	261
DO-IT-YOURSELF SERVICE PRECAUTIONS	261
BONNET	263
POSITIONING A FLOOR JACK	264
ENGINE COMPARTMENT OVERVIEW	266
ENGINE OIL	266

COOLANT	270
RADIATORS AND CONDENSER	272
BRAKE FLUID	272
WASHER FLUID	273
TYRES	274
WHEELS	278
AIR CONDITIONING FILTER	279
12-VOLT AUXILIARY BATTERY	280
CHECKING AND REPLACING FUSES	283
LIGHT BULBS	291
REPLACING THE REMOTE CONTROL TRANSMITTER BATTERY	303

WHEN TROUBLE ARISES 305

Essential information 306

EMERGENCY FLASHERS	306
IF YOUR VEHICLE NEEDS TO BE TOWED ..	306
IF YOU THINK SOMETHING IS WRONG ...	310

Steps to take in an emergency 311

IF A WARNING LIGHT ILLUMINATES, A BUZZER SOUNDS OR A WARNING MESSAGE IS DISPLAYED	311
IF YOU HAVE A FLAT TYRE	312
IF THE HYBRID SYSTEM WILL NOT START	319
EMERGENCY START FUNCTION	320
IF THE SHIFT LEVER CANNOT BE MOVED FROM P POSITION	320
IF YOU LOSE YOUR KEYS	320
IF THE ELECTRONIC KEY DOES NOT OPERATE PROPERLY	321
IF THE 12-VOLT AUXILIARY BATTERY IS DISCHARGED	322
JUMP STARTING	323
IF YOUR VEHICLE OVERHEATS	325
IF YOUR VEHICLE BECOMES STUCK	328
IF YOUR VEHICLE HAS TO BE STOPPED IN AN EMERGENCY	328

VEHICLE SPECIFICATIONS 331

Specifications 332

DIMENSIONS	332
ENGINE NUMBER	332
VEHICLE IDENTIFICATION NUMBER (VIN)	332
PETROL ENGINE	333
FUEL	334
ELECTRIC MOTOR	334
HYBRID BATTERY	334
LUBRICATION	335
COOLING SYSTEM	336
IGNITION	336
ELECTRICAL SYSTEM	336
TRANSMISSION	337
BRAKES	337
STEERING	337
TYRES AND WHEELS	338

Customisation 339

CUSTOMISABLE FEATURES	339
CUSTOMISING DOOR LOCK AND UNLOCK FUNCTIONS	344

ALPHABETICAL INDEX 345

WHAT TO DO IF... / SERVICE STATION INFORMATION 354

Pictorial Index - Exterior

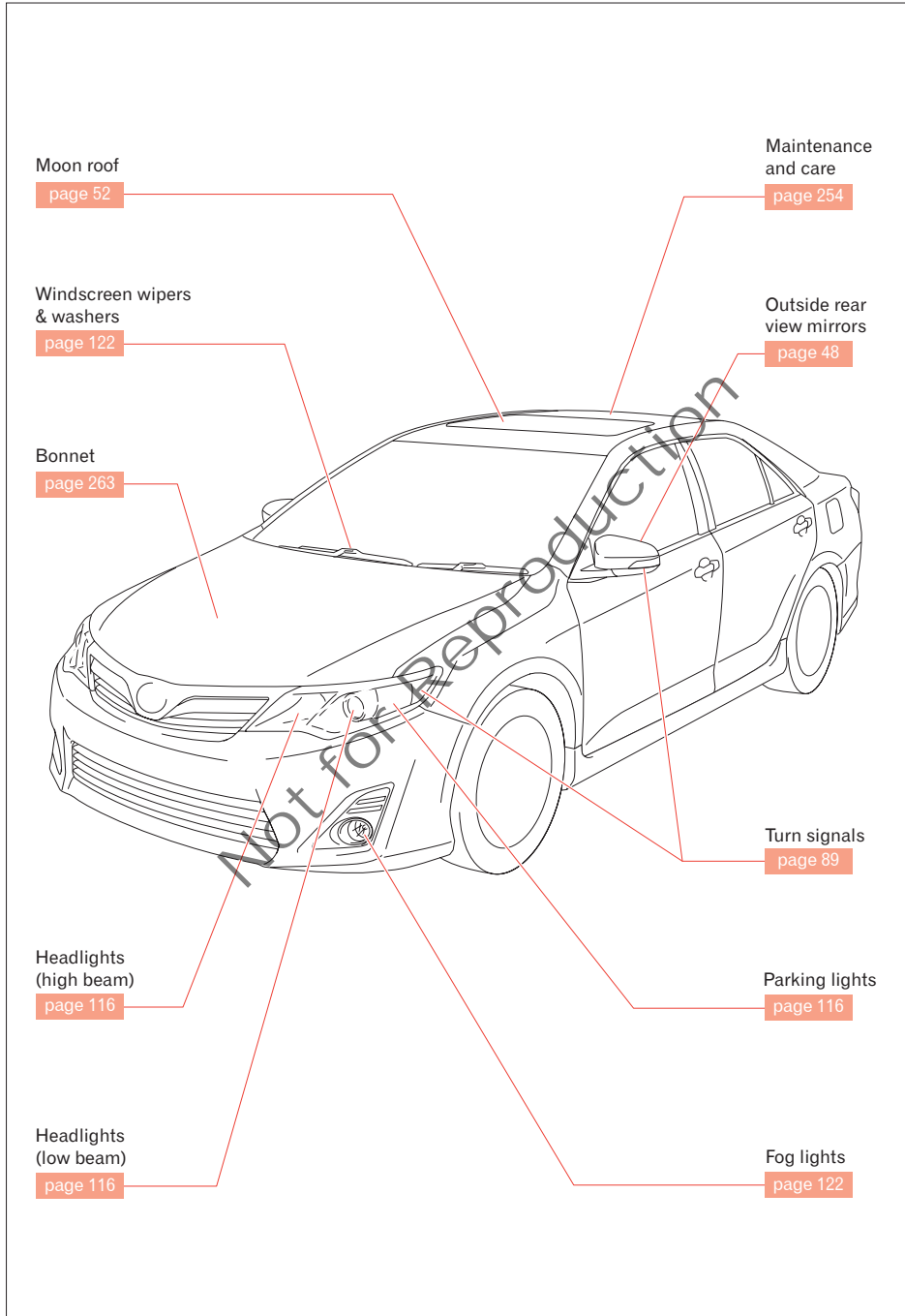

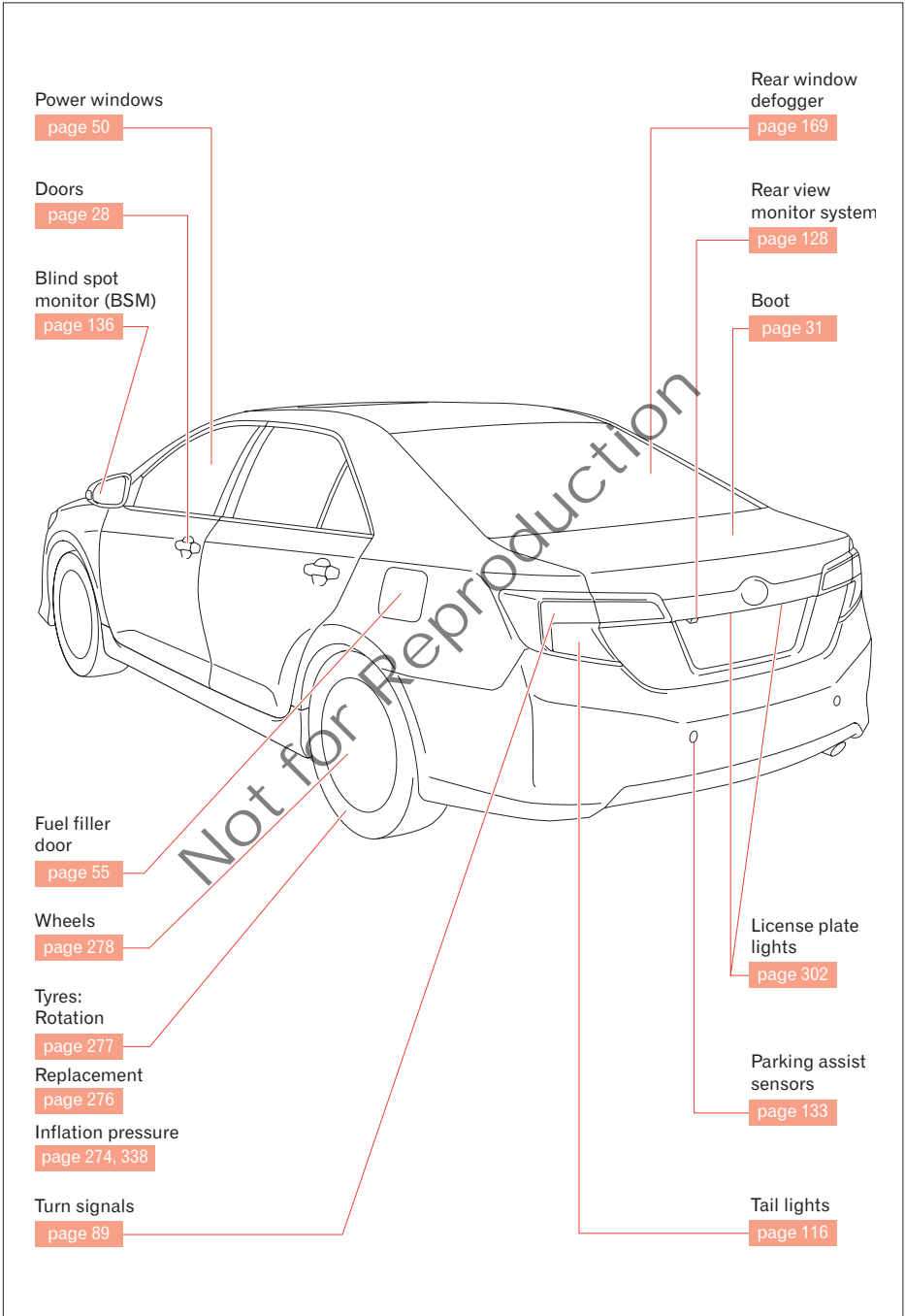

Pictorial Index - Interior

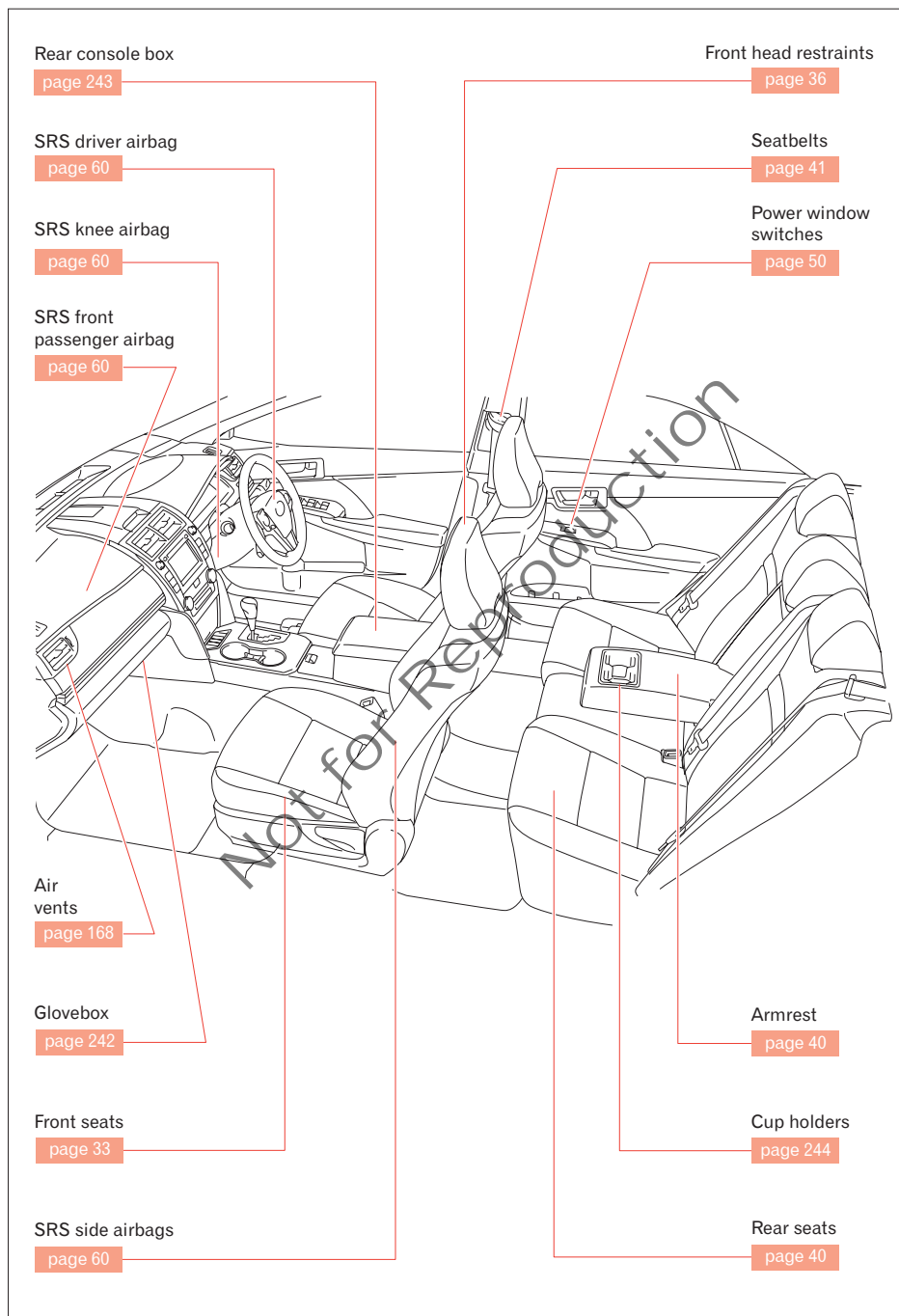

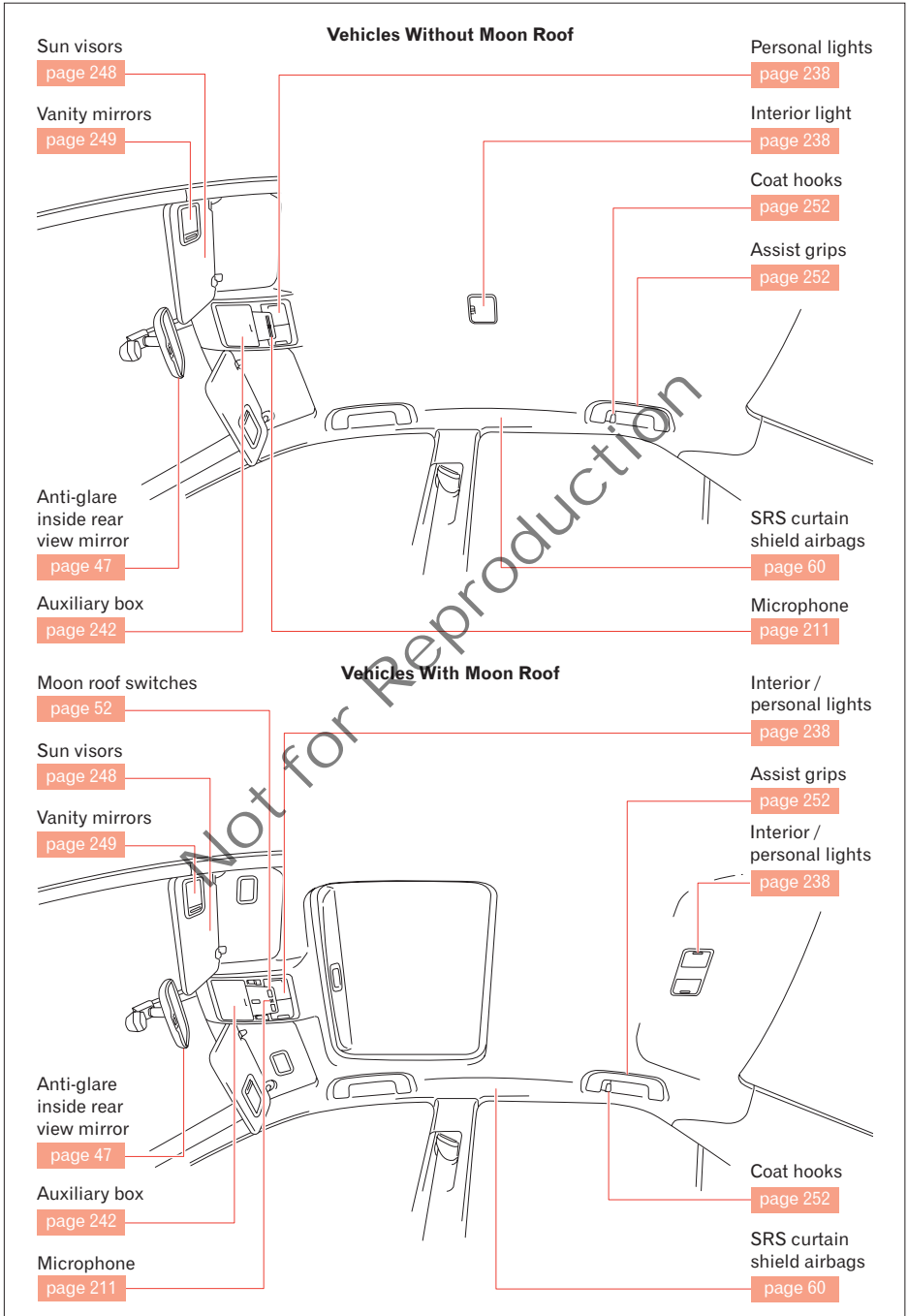

Pictorial Index - Interior

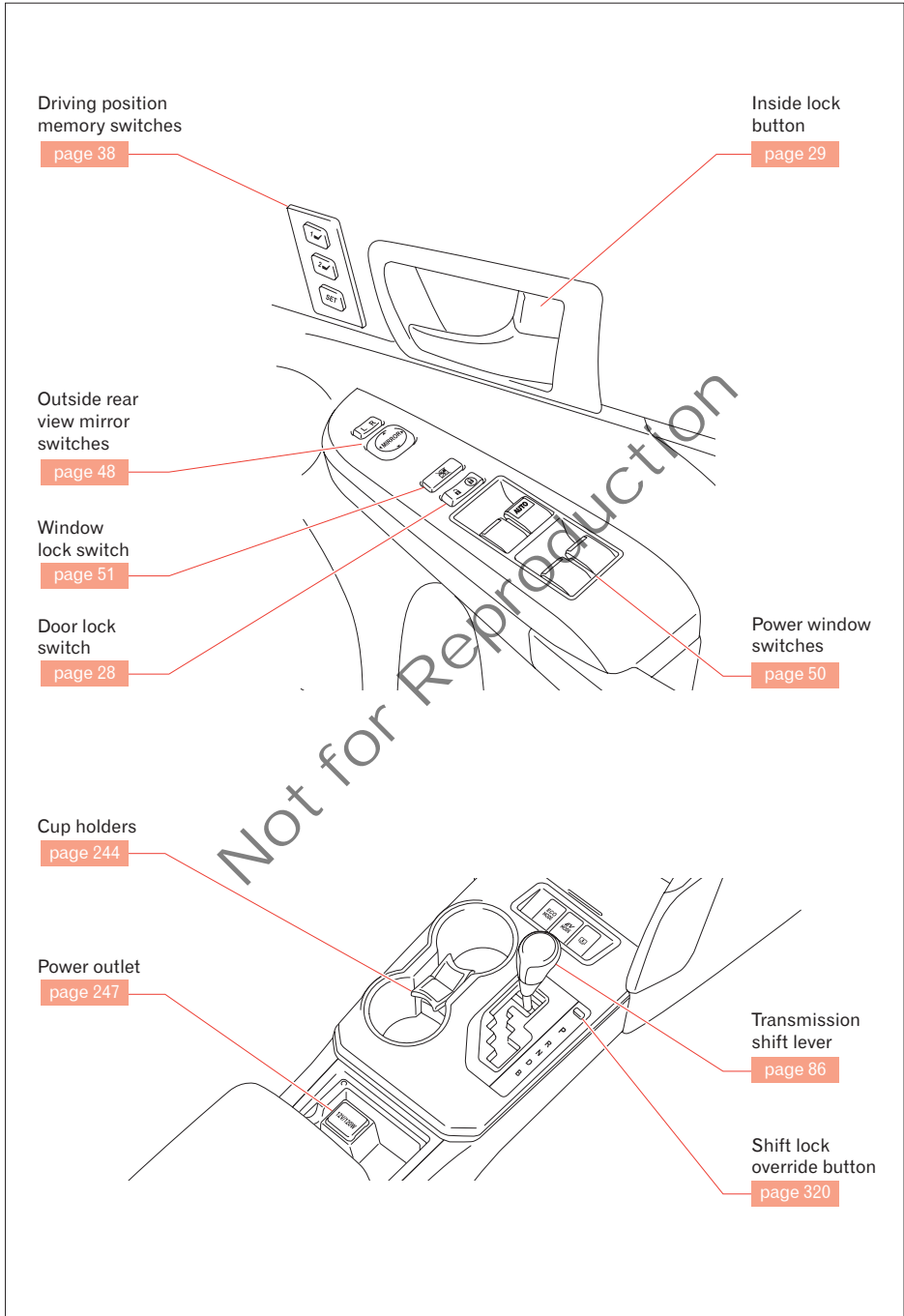

Pictorial Index - Interior

Windscreen wiper and washer switch

page 122

Clock

page 247

Touch-screen audio system

page 170

Navigation system*

Gauges and meters

page 91

Headlight switch

page 116

Turn signal lever

page 89

Fog light switch

page 122

Bonnet lock release lever

page 263

Parking brake pedal

page 90

Floor mat

page 250

Tilt and telescopic steering lock release lever

page 46

Horn

page 90

Fuel filler door opener

page 55

Boot lid opener

page 20

Power switch

page 78

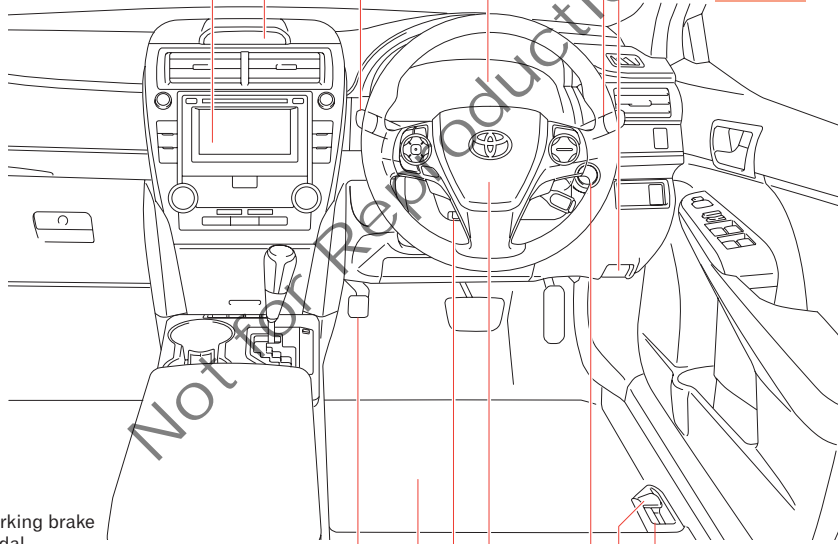

* Refer to separate "Navigation System Owner's Manual"

Pictorial Index - Interior

Security indicator
page 57

Emergency flasher
page 306

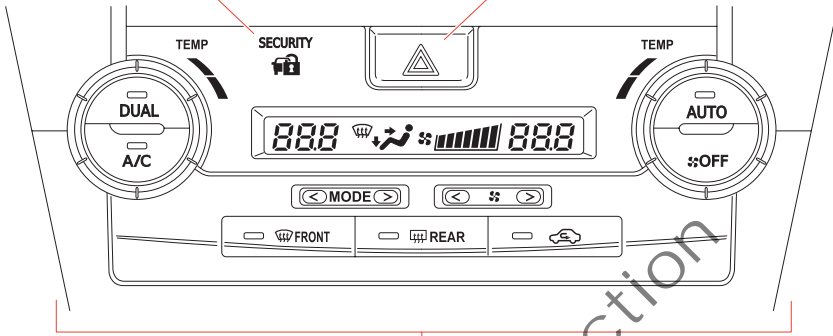

Automatic air conditioning system

Audio remote control switches
page 209

DISP button
page 111

Talk switch*

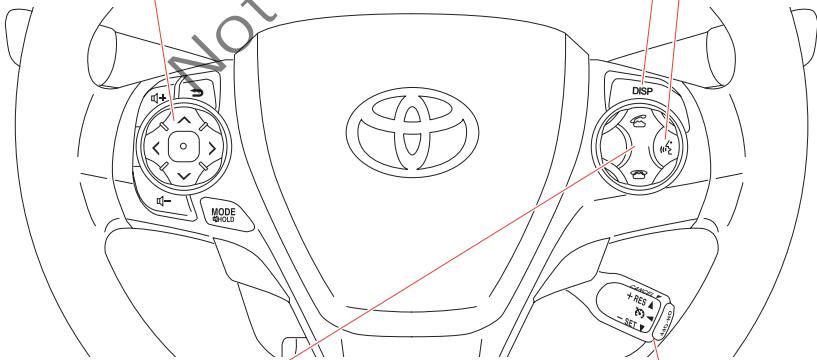

Telephone switches
page 211

Cruise control switch
page 126

* Refer to separate "Navigation System Owner's Manual"

AUX port

page 190, 200

USB port

page 195

Power outlet

page 247

ECO MODE
switch

page 88

EV MODE
switch

page 83

Rear electric
sunshade
switch

page 249

Parking
assist-sensor
switch





















page 133





Blind spot
monitor (BSM)
main switch

page 136

Not for Reproduction

INSTRUMENT PANEL INDICATOR SYMBOLS

	Brake system warning light (red indicator)* ¹
	Brake system warning light (yellow indicator)* ^{1,3}
	Charging system warning light* ¹
	Low engine oil pressure warning light* ¹
	Malfunction indicator lamp* ¹
	SRS warning light* ¹
	Anti-lock brake system (ABS) warning light* ¹
	Turn signal indicators (refer to page 89)
	Automatic high beam indicator light (refer to page 118)* ³
	Headlight high beam indicator (refer to page 116)
	Tail light indicator (refer to page 116)
	Front fog light indicator (refer to page 122)
	Slip indicator light* ^{1,2}
	Electric power steering (EPS) system warning light* ¹
	Open door warning light* ¹
	Low fuel level warning light* ¹
	Driver's and front passenger's seatbelt reminder light* ¹
	Rear passengers' seatbelt reminder lights (centre panel)* ¹
	Master warning light* ¹
	High coolant temperature warning light (the right most segment of the light flashes)* ¹
	Driving ready indicator (refer to page 79)

ECO MODE	ECO MODE indicator (refer to page 88)
	EV drive mode indicator(refer to page 83)
	EV indicator (refer to page 83)
	Cruise control indicator light (refer to page 126)
SET	Cruise control set indicator (refer to page 127)
	Security indicator (centre panel - refer to page 57)

*1 For details refer to "Indicators and warning lights" on page 95.

*2 If this light comes on, refer to "Driving assist systems" on page 140.

*3 The light comes on in yellow to indicate a malfunction.

Not for Reproduction

For your information

IMPORTANT INFORMATION

CAUTION

Your vehicle is a hybrid vehicle. It has characteristics different from conventional vehicles. You must understand the characteristics of your vehicle very well and handle it carefully. Read this manual and follow the instructions. For an explanation of the characteristics of the hybrid system refer to “Hybrid system overview” on page 2.

SYMBOLS USED THROUGHOUT THIS MANUAL

Cautions & Notices

CAUTION

This is a warning against anything which may result in serious injury or death to people if the warning is ignored. You are informed about what you must or must not do in order to reduce the risk of injury to yourself and others.

NOTICE



This is a warning against anything which may cause damage to the vehicle or its equipment if the warning is ignored. You are informed about what you must or must not do in order to avoid or reduce the risk of damage to your Toyota and its equipment.

SAFETY SYMBOL



Throughout this manual, you will also see the symbol of a circle with a slash through it. This indicates a serious warning, e.g. “Do not”, “Do not do this”, or “Do not let this happen”.

ARROWS INDICATING OPERATIONS

-  Indicates the action (pushing, turning, etc.) used to operate switches and other devices.
-  Indicates the outcome of an operation (e.g. a lid opens).

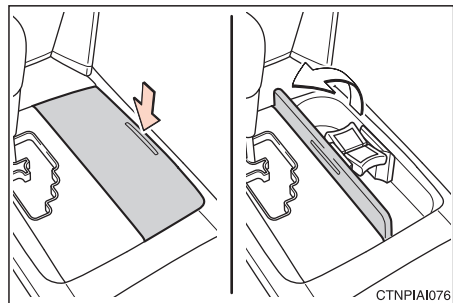

OWNER'S MANUAL

Please note that this manual covers all models and all equipment, including options. Therefore, you may find information for equipment not installed on your vehicle.

All specifications provided in this manual are current at the time of printing. However, due to Toyota's product improvement policy, we reserve the right to make changes at any time without notice. **For the latest vehicle specifications, please refer to www.toyota.com.au**

Depending on specifications, the vehicle shown in the illustrations may differ from your vehicle in terms of equipment.

ABBREVIATIONS

Abbreviations	Meaning
A/C	Air Conditioning
ABS	Anti-lock Brake System
ACC	Accessory
ALR	Automatic Locking Retractor
BSM	Blind Spot Monitor
CRS	Child Restraint System
DISP	Display
ECO	Economy/Ecology
ECU	Electronic Control Unit
EDR	Event Data Recorder
ELR	Emergency Locking Retractor
EPSX	Electric Power Steering
EV	Electric vehicle
LED	Light Emitting Diode
OBD	On Board Diagnostics
OPP	Object Push Profile
PBAP	Phone Book Access Profile
SRS	Supplemental Restraint System
TRC	Traction Control
VIN	Vehicle Identification Number
VSC	Vehicle Stability Control

For your information

ACCESSORIES, SPARE PARTS AND MODIFICATION OF YOUR TOYOTA

A wide variety of non-genuine spare parts and accessories for Toyota vehicles are currently available on the market. Using non-genuine products may adversely affect the safety of your vehicle, even though these parts may be approved by certain authorities in Australia. Toyota therefore cannot accept any liability or guarantee spare parts and accessories which are not genuine Toyota products, nor does Toyota accept responsibility for replacement or installation involving non-genuine parts.

This vehicle should not be modified with non-genuine Toyota products. Modification with non-genuine Toyota products could affect its performance, safety or durability, and may even violate governmental regulations. In addition, damage or performance problems resulting from the modification may not be covered under warranty.

INSTALLATION OF A MOBILE TWO-WAY RADIO SYSTEM

The installation of a mobile two-way radio system in your vehicle may affect electronic systems such as the multi-port fuel injection system/sequential multi-port fuel injection system, cruise control system, anti-lock brake system, SRS airbag system or seatbelt pretensioner system. Ensure to check with your Toyota dealer for precautionary measures or special instructions regarding installation.

NOTICE

High voltage parts and cables on hybrid vehicles emit approximately the same amount of electromagnetic waves as the conventional petrol powered vehicles or home electronic appliances.

Unwanted noise may occur in mobile two-way radio reception.

HYBRID BATTERY

The hybrid battery has a limited service life. Call your Toyota dealer for information about recycling or disposal of the hybrid battery.

DISPOSING OF YOUR TOYOTA

Disposal of the hybrid battery

CAUTION

In the event that your vehicle must be disposed of, contact your Toyota dealer or a qualified service shop. If your vehicle is disposed of without the hybrid battery having been removed, there is a danger of serious electric shock if high voltage parts, cables and their connectors are touched. The hybrid batteries must be disposed of by your Toyota dealer or a qualified repair shop. If the hybrid batteries are not disposed of correctly, they may cause electric shock that can result in death or serious injury.

⚠ CAUTION

Never resell, hand over or modify the hybrid battery. To prevent accidents, hybrid batteries that have been removed from a disposed vehicle are collected through Toyota dealers. Do not dispose of the battery yourself. Unless the battery is properly collected, the following may occur, resulting in death or serious injury:

- The hybrid battery may be illegally disposed of or dumped, and someone may touch a high voltage part, resulting in an electric shock.
- The hybrid battery is intended to be used exclusively with your hybrid vehicle. If the hybrid battery is used outside of your vehicle or modified in any way, accidents such as electric shock, heat generation, smoke generation, an explosion and electrolyte leakage may occur.

When reselling or handing over your vehicle, the possibility of an accident is extremely high because the person receiving the vehicle may not be aware of these dangers.

SRS airbag and seatbelt pretensioner

The SRS airbag and seatbelt pretensioner devices in your Toyota contain explosive chemicals. If the vehicle is disposed of with the airbags and seatbelt pretensioners left as they are, this may cause an accident such as fire. Ensure to have the systems of the SRS airbag and seatbelt pretensioner removed and disposed of by a qualified service centre or by your Toyota dealer before you dispose of your vehicle.

HIGH VOLTAGE CAUTIONS

⚠ CAUTION

The vehicle has high voltage DC and AC systems as well as a 12-volt DC system. DC and AC high voltage is very dangerous and can cause severe burns and electric shock that may result in death or serious injury.

- **Never touch, disassemble, remove or replace high voltage parts, cables and their connectors. For the location of high voltage parts and cables refer to “Hybrid system precautions” on page 5. Touching, disassembling, removing or replacing those parts and cables can cause severe burns or electric shock that may result in death or serious injury.**
- **Never try to open the service plug access hole located in the boot. The service plug is used only when the vehicle is serviced and is subject to high voltages. Touching the service plug can cause severe burns or electric shock that may result in death or serious injury.**
- **The hybrid system uses high voltages up to 650 V. The system can be hot during and after starting. Be careful of both the high voltage and the high temperature. Obey the caution labels attached to the vehicle.**

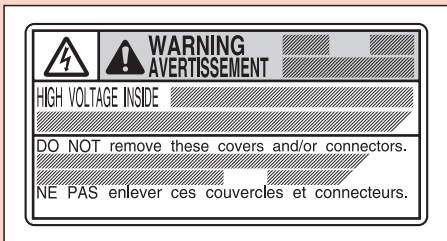

For your information

ROAD ACCIDENT CAUTIONS

CAUTION

Observe the following precautions to reduce the risk of death or serious injury.

- Pull your vehicle off the road, put the transmission in P position, apply the parking brake, turn the hybrid system off and carry the key.
- In order to avoid death or serious injury, do not touch the high voltage wiring, connectors or high voltage parts (power control unit, hybrid battery, etc.). For the location of high voltage parts and cables refer to “Hybrid system precautions” on page 5.
- If exposed electric wires are protruding inside or outside of your vehicle, an electric shock may occur. Never touch the electric wires.
- If fluid leaks or gets into some parts of the vehicle, never touch it because it may be strong alkaline electrolyte from the hybrid battery. If it contacts your skin or eyes, wash it off immediately with a large amount of water or if possible, boric acid solution. Get immediate medical attention in order to help avoid serious injury.
- If a fire occurs in the hybrid vehicle, leave the vehicle as soon as possible. Never use a fire extinguisher that is not meant for use on electric fires. Using a small amount of water may also be dangerous.
- If your vehicle needs to be towed (except as outlined on page 306), do it with the front wheels raised. If the wheels with the motor generator are on the ground when towing, the motor may continue to generate electricity. This may cause electricity leakage. Depending on the severity of the damage, electricity leakage may cause a fire. Refer to “If your vehicle needs to be towed” on page 306.

SMART ENTRY AND START SYSTEM

CAUTION

Users of any electrical medical devices such as implanted pacemakers should consult the manufacturer of the device for information about its operation under the influence of radio waves. Radio waves could have unexpected effects on the operation of such medical devices. For details, refer to “Smart entry and start system” on page 19.

TOYOTA AND PRIVACY

Toyota is committed to protecting your privacy and is required to comply with the National Privacy Principles in the Privacy Act 1988 (Cth) when it collects and handles your personal information. This includes providing you with the right to access and correct your personal information (subject to some exceptions allowed by law).

For further information about Toyota and privacy, please see the Toyota Privacy Policy (available at www.toyota.com.au). You can also contact us by calling 1800 252 097, or by sending your query to the Toyota Privacy Contact, PO Box 187 Caringbah, NSW, 2229, Australia.

VEHICLE CONTROL AND OPERATION DATA RECORDING

Your Toyota is equipped with sophisticated computers that record certain information about your vehicle's operation, such as:

- Engine speed
- Accelerator status
- Brake status
- Vehicle speed
- Shift position

The data recorded varies according to the grade level and options the vehicle is equipped with. The computers do not record conversations, sound or pictures.

Data usage

Toyota may use the data recorded in these computers to diagnose malfunctions, conduct research and development, and improve quality.

Toyota will not disclose the recorded data to a third party except:

- With the consent of the vehicle owner or with the consent of the lessee if the vehicle is leased
- In response to an official request by the police, a court of law or a government agency
- For research purposes where the data is not tied to a specific vehicle or vehicle owner

Event data recorder

This vehicle is equipped with an event data recorder (EDR). The main purpose of an EDR is to record, in certain crash or near crash-like situations, such as an air bag deployment or hitting a road obstacle, data that will assist in understanding how a vehicle's systems performed. The EDR is designed to record data related to vehicle dynamics and safety systems for a short period of time, typically 30 seconds or less.

The EDR in this vehicle is designed to record such data as:

- How various systems in your vehicle were operating
- How far (if at all) the driver was depressing the accelerator and / or brake pedal
- How fast the vehicle was travelling.

This data can help provide a better understanding of the circumstances in which crashes and injuries occur.

NOTE: The EDR will not record data in all crash situations; no data is recorded by the EDR under normal driving conditions and no personal data (e.g., name, gender, age, and crash location) is recorded. However, other parties, such as law enforcement, could combine the EDR data with the type of personally identifying data routinely acquired during a crash investigation.

To read data recorded by an EDR, special equipment is required, and access to the vehicle or the EDR is needed. In addition to the vehicle manufacturer, other parties, such as law enforcement, that have the special equipment, can read the information if they have access to the vehicle or the EDR.

For your information

Disclosure of the EDR data

Toyota will not disclose the data recorded in an EDR to a third party except when:

- An agreement from the vehicle's owner (or the lessee for a leased vehicle) is obtained
- In response to an official request by the police, a court of law or a government agency
- For use by Toyota in a law suit.

However, if necessary, Toyota may:

- Use the data for research on vehicle safety performance
- Disclose the data to a third party for research purposes without disclosing information about the specific vehicle or vehicle owner.

CAUTION

General precautions while driving

- **Driving under the influence:** Never drive your vehicle when under the influence of alcohol or drugs (including prescription medications and over-the-counter preparations) that have impaired your ability to operate your vehicle. Please consult a medical practitioner to confirm whether medications may affect your ability to drive safely. Alcohol and certain drugs delay reaction time, impair judgment and reduce coordination, which could lead to an accident that will hurt or kill you, your occupants or others.
- **Defensive driving:** Always drive defensively. Anticipate mistakes that other drivers or pedestrians might make and be ready to avoid accidents.
- **Driver distraction:** Always give your full attention to driving. Anything that distracts the driver, such as adjusting controls, talking on a mobile phone or reading can result in a collision with resulting death or serious injury to you, your occupants or others. These activities may also be illegal.

General precaution regarding children's safety

- Never leave children unattended in the vehicle, and never allow children to have or use the key.
- Children may be able to start the vehicle or shift the vehicle into neutral. There is also a danger that children may injure themselves by playing with the windows, the moon roof, or other features of the vehicle.
- Never leave children unattended in a vehicle as heat build-up or extremely cold temperatures inside the vehicle can be fatal to children.

BEFORE DRIVING

Toyota hybrid system	2
HYBRID SYSTEM OVERVIEW.....	2
HYBRID SYSTEM PRECAUTIONS.....	5
ENERGY MONITOR / CONSUMPTION SCREEN.....	8
Key information	15
KEYS.....	15
Opening, closing and locking the doors	17
WIRELESS REMOTE CONTROL.....	17
SMART ENTRY AND START SYSTEM	19
DOORS.....	28
BOOT LID.....	31
Adjustable components	33
SEATS.....	33
FRONT SEATS.....	33
FRONT HEAD RESTRAINTS.....	36
DRIVING POSITION MEMORY SYSTEM	38
REAR SEATS.....	40
SEATBELTS.....	41
TILT AND TELESCOPIC STEERING WHEEL.....	46
ANTI-GLARE INSIDE REAR VIEW MIRROR.....	47
AUTO ANTI-GLARE INSIDE REAR VIEW MIRROR.....	47
OUTSIDE REAR VIEW MIRRORS	48
Opening and closing the windows and moon roof ...	50
POWER WINDOWS	50
MOON ROOF.....	52
Refuelling	55
FUEL TANK CAP	55
Theft deterrent system	57
ENGINE IMMOBILISER SYSTEM.....	57
ALARM.....	58
Safety information	60
SRS COMPONENTS	60
SEATBELT PRETENSIONERS.....	60
SRS AIRBAGS.....	62
SRS AIRBAG PRECAUTIONS	67
CHILD RESTRAINT	73
CHILD RESTRAINT SYSTEM	74
FLOOR MAT.....	76

Toyota hybrid system

Toyota hybrid system

HYBRID SYSTEM OVERVIEW

Your vehicle is a hybrid vehicle. It has characteristics different from conventional vehicles. Be sure you are familiar with the characteristics of your vehicle, and operate with due care.

The hybrid system combines the use of a petrol engine and an electric motor according to driving conditions, improving fuel efficiency and reducing exhaust emissions.

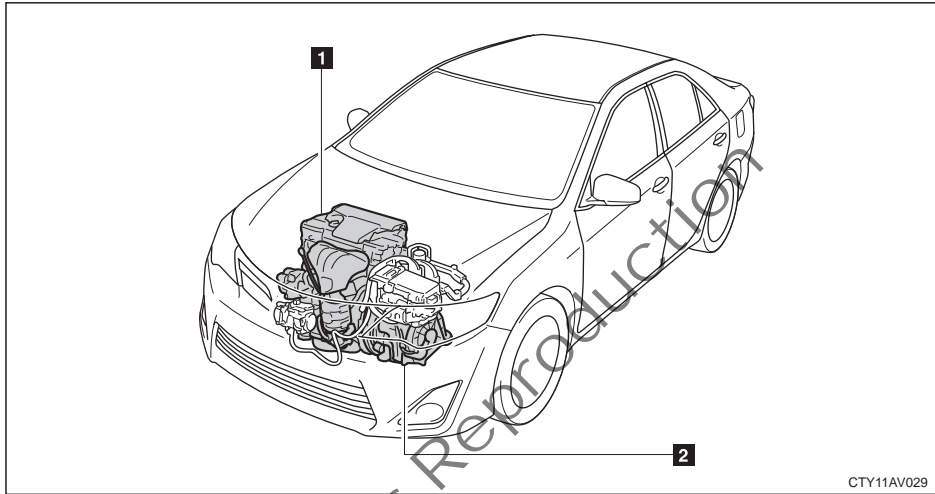

1	Petrol engine	2	Electric motor
---	---------------	---	----------------

When stopped / during start-off:

- The petrol engine stops when the vehicle is stopped. During start-off, the electric motor drives the vehicle. At slow speeds or when travelling down a gentle slope, the engine is stopped and the electric motor is used.

During normal driving:

- The petrol engine is predominantly used. The electric motor charges the hybrid battery as necessary.

When accelerating sharply:

- The power of the hybrid battery is added to that of the petrol engine via the electric motor.

When braking (regenerative braking):

- The electric motor charges the hybrid battery.

Regenerative braking

In the following situations, kinetic energy is converted to electric energy and deceleration force can be obtained in conjunction with the recharging of the hybrid battery.

- The accelerator pedal is released.
- The brake pedal is depressed with the shift lever in D or B position.

EV indicator

The EV indicator comes on when the vehicle is being driven using only the electric motor.

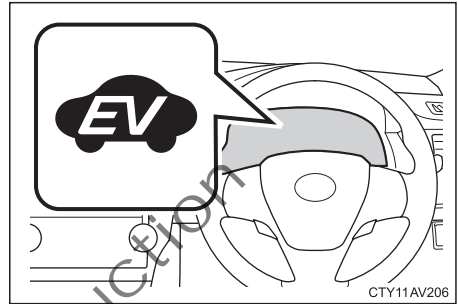

Conditions under which the petrol engine may not stop

The petrol engine starts and stops automatically. However, it may not stop automatically in the following conditions:

- During petrol engine warm-up
- During hybrid battery charging
- When the temperature of the hybrid battery is high or low
- When the heater is switched on

Charging the hybrid battery

- As the petrol engine charges the hybrid battery, the battery does not need to be charged from an outside source. However, if the vehicle is left parked for a long time the hybrid battery will slowly discharge. For this reason, be sure to drive the vehicle at least once every few months for at least 30 minutes or 16 km. If the hybrid battery becomes fully discharged and you are unable to jump-start the vehicle with the 12-volt auxiliary battery, contact your Toyota dealer.
- If the shift lever is in N position, the hybrid battery will not be charged. Always put the shift lever in P position when the vehicle is stopped. When driving in heavy traffic, operate the vehicle with the shift lever in D or B position to avoid discharging the battery.

Charging the 12-volt auxiliary battery

Refer to "Jump starting" on page 323.

After the 12-volt auxiliary battery has discharged or has been changed or removed

The petrol engine may not stop even if the vehicle is running on the hybrid battery. If this continues for a few days, contact your Toyota dealer.

Toyota hybrid system

Sounds and vibrations specific to a hybrid vehicle

There may be no engine sounds or vibrations even though the vehicle is able to move. Always shift the shift lever to P position when parked.

The following sounds or vibrations may occur when the hybrid system is operating and do not indicate a malfunction.

- Motor sounds may be heard from the engine compartment.
- Sounds may be heard from the hybrid battery behind the rear seats when the hybrid system starts or stops.
- Sounds from the hybrid system may be heard when the boot lid is open.
- Sounds may be heard from the transmission when the hybrid system starts or stops.
- Engine sounds may be heard when accelerating sharply.
- Sounds may be heard due to regenerative braking when the brake pedal is depressed.
- Vibration may be felt when the petrol engine starts or stops.
- Cooling fan sounds may be heard from the air intake vent beside the rear left seat.

Maintenance, repair, recycling, and disposal

CAUTION

In the event that your vehicle must be disposed of, contact your Toyota dealer or a qualified service shop. If your vehicle is disposed of without the hybrid battery having been removed, there is a danger of serious electric shock if high voltage parts, cables and their connectors are touched. The hybrid batteries must be disposed of by your Toyota dealer or a qualified repair shop. If the hybrid batteries are not disposed of correctly, they may cause electric shock that can result in death or serious injury.

HYBRID SYSTEM PRECAUTIONS

Take care when handling the hybrid system, as it contains a high voltage system (about 650V maximum) as well as parts that become extremely hot when the hybrid system is operating. Obey the caution labels attached to the vehicle.

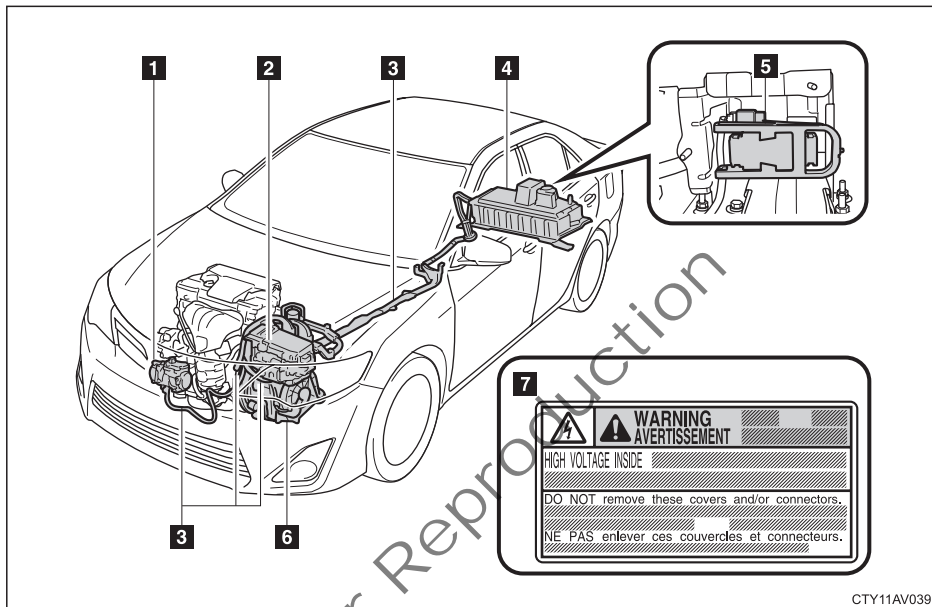

CTY11AV039

1	Air conditioning compressor	5	Service plug
2	Power control unit with DC / DC converter	6	Electric motor
3	High voltage cables (orange)	7	Caution label
4	Hybrid battery		

Hybrid warning message

A message is automatically displayed when a malfunction occurs in the hybrid system or an improper operation is attempted.

If a warning message is shown on the multi-information display, read the message and follow the instructions. Refer to "Warning messages" on page 100.

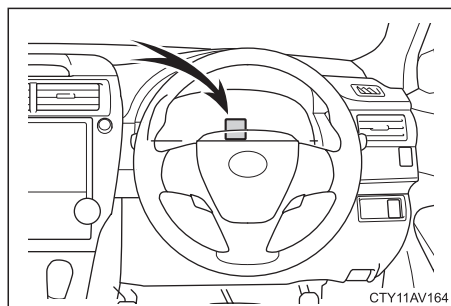

CTY11AV164

Toyota hybrid system

Hybrid battery air vent

There is an air intake vent beside the rear left seat for the purpose of cooling the hybrid battery. If the vent becomes blocked, the hybrid battery may overheat, leading to a reduction in hybrid battery output.

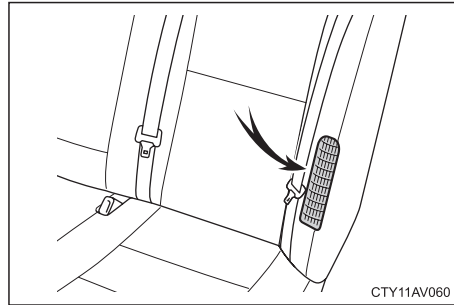

⚠ NOTICE

Hybrid battery air vent

- Do not place foreign objects over or in front of the air vent. The hybrid battery may overheat and be damaged.
- Clean the air vent regularly to prevent the hybrid battery from overheating.
- Do not wet the air vent as this may cause a short circuit and damage the hybrid battery.
- Do not carry large amounts of water such as water cooler bottles in the vehicle. If water spills onto the hybrid battery, the battery may be damaged.

Emergency shut off system

When a certain level of impact is detected by the impact sensor, the emergency shut off system blocks off the high voltage current and stops the fuel pump to minimise the risk of electrocution and fuel leakage. If the emergency shut off system activates, your vehicle will not restart. To restart the hybrid system, contact your Toyota dealer.

INFORMATION

If a warning light comes on, a warning message is displayed, or the 12- volt auxiliary battery is disconnected

The hybrid system may not start. In that case, try to start the system again. If the READY indicator does not come on, contact your Toyota dealer.

Running out of fuel

When the vehicle has run out of fuel and the hybrid system cannot be started, refuel the vehicle with at least enough petrol to make the low fuel level warning light (refer to "Indicators and warning lights" on page 95) go off. If there is only a small amount of fuel, the hybrid system may not be able to start. (The minimum amount of fuel to add to make the low fuel level warning light go out is about 11.4 L when the vehicle is on a level surface. This value may vary when the vehicle is on a slope.)

INFORMATION

Electromagnetic waves

- High voltage parts and cables on the hybrid vehicles incorporate electromagnetic shielding, and therefore emit approximately the same amount of electromagnetic waves as conventional petrol powered vehicles or home electronic appliances.
- Your vehicle may cause sound interference in some third party-produced radio parts.

Hybrid battery

The hybrid battery has a limited service life. The lifespan of the hybrid battery can change in accordance with driving style and driving conditions.

⚠ CAUTION

High voltage precautions

The vehicle has high voltage DC and AC systems as well as a 12-volt system. DC and AC high voltage is very dangerous and can cause severe burns and electric shock that may result in death or serious injury.

- Never touch, disassemble, remove or replace the high voltage parts, cables or their connectors.
- The hybrid system will become hot after starting as the system uses high voltage. Be careful of both the high voltage and the high temperature, and always obey the caution labels attached to the vehicle.
- Never try to open the service plug access hole located in the luggage compartment. The service plug is used only when the vehicle is serviced and is subject to high voltage.

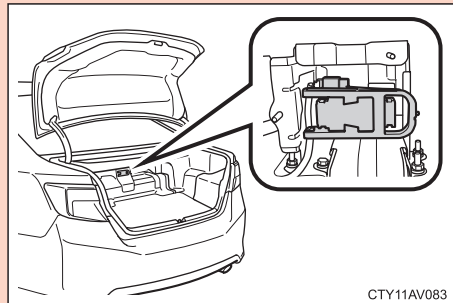

Nickel-metal hydride battery

Your vehicle contains a sealed nickel-metal hydride battery. If disposed of improperly, it is hazardous to the environment and there is a risk of severe burns and electrical shock that may result in death or serious injury.

Toyota hybrid system

ENERGY MONITOR / CONSUMPTION SCREEN

You can view the status of your hybrid system on the multi-information display and the navigation system or display audio system.

1. Navigation system or Display Audio system.
2. Multi-information display.

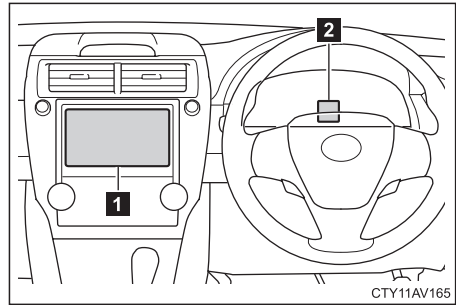

Energy monitor

Vehicles with Navigation system –

Press INFO.

If the TRIP INFORMATION or PAST RECORD screen is displayed, touch ENERGY.

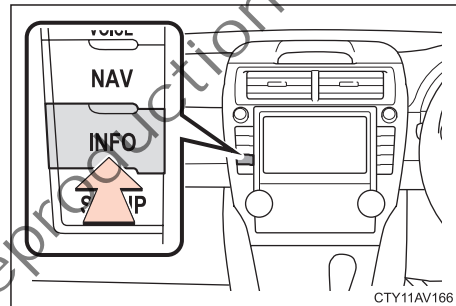

Vehicles with Display Audio system –

Press CAR.

If the TRIP INFORMATION or PAST RECORD screen is displayed, touch ENERGY.

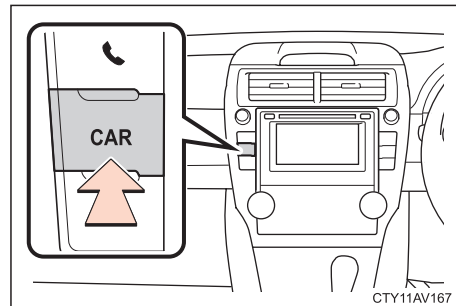



Multi-information display (all vehicles) –

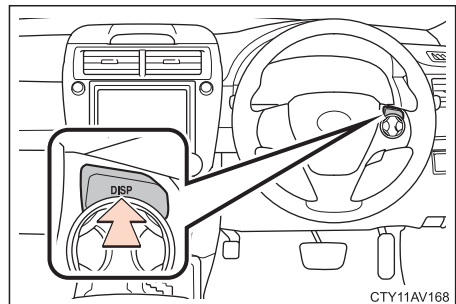

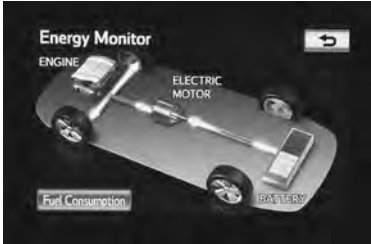

Push the DISP switch on the steering wheel several times to select the energy monitor display. Refer to “Multi-information display” on page 100.

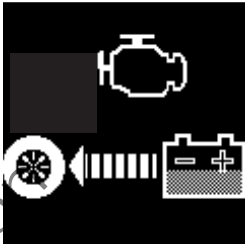
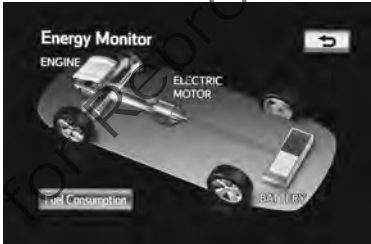
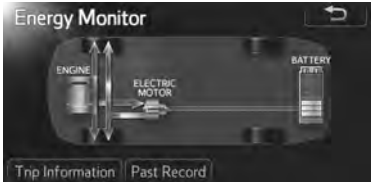
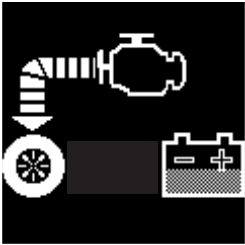



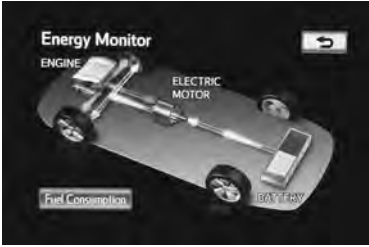

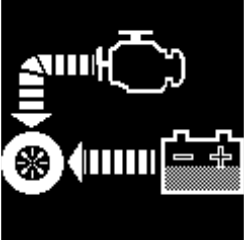
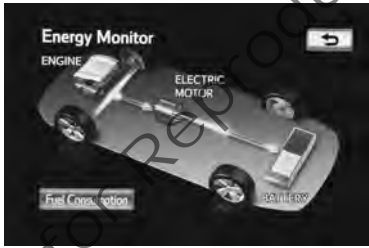
Energy monitor screen displays

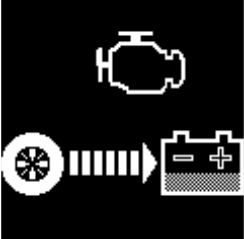
	Navigation system [N] or Display Audio system [D]	Multi-information display
When the vehicle is powered by the electric motor	<p>N</p>  <p>D</p> 	
When the vehicle is powered by the petrol engine	<p>N</p>  <p>D</p> 	

Toyota hybrid system

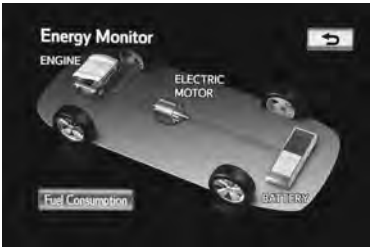
	Navigation system [N] or Display Audio system [D]	Multi-information display
When the vehicle is powered by both the petrol engine and the electric motor	<p>N</p>  <p>D</p> 	
When the vehicle is charging the hybrid battery	<p>N</p>  <p>D</p> 	

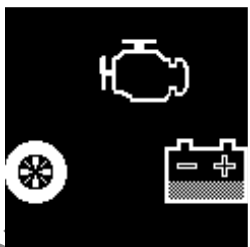
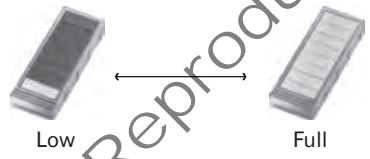
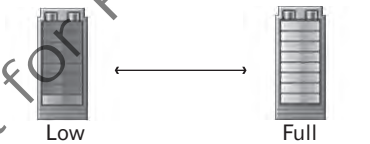
Toyota hybrid system

	Navigation system [N] or Display Audio system [D]	Multi-information display
When there is no energy flow	<p>N</p>  <p>D</p> 	
Hybrid battery status	<p>N</p>  <p>D</p> 	

Toyota hybrid system

Trip information screen

Vehicles with Navigation system –

Press INFO. Refer to “Energy monitor” on page 8.

If the ENERGY MONITOR or PAST RECORD screen is displayed, touch TRIP INFORMATION.

1. Fuel consumption in the past 15 minutes.
2. Displays the average vehicle speed since the hybrid system was started.
3. Displays the elapsed time since the hybrid system was started.
4. Cruising range.
5. Regenerated energy in the past 15 minutes.
One symbol indicates 50 Wh. Up to 5 symbols are shown.

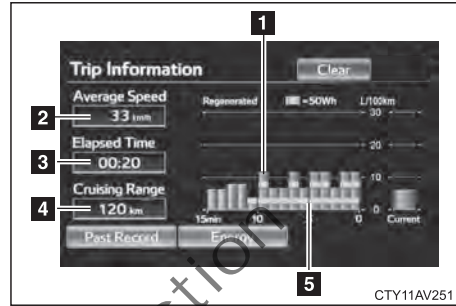

The image is an example only and may vary slightly from actual conditions.

Vehicles with Display Audio system –

Press CAR. Refer to “Energy monitor” on page 8.

If the ENERGY MONITOR or PAST RECORD screen is displayed, touch TRIP INFORMATION.

1. Fuel consumption in the past 15 minutes.
2. Displays the average vehicle speed since the hybrid system was started.
3. Displays the elapsed time since the hybrid system was started.
4. Cruising range.
5. Regenerated energy in the past 15 minutes.
One symbol indicates 50 Wh. Up to 5 symbols are shown.

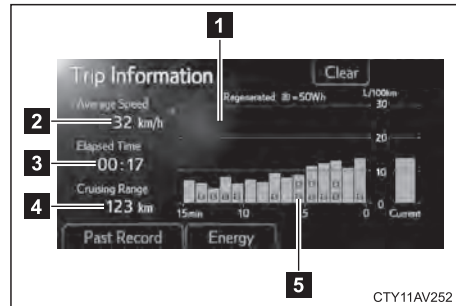

The image is an example only and may vary slightly from actual conditions.

Past record screen

Vehicles with Navigation system –

Press INFO. Refer to “Energy monitor” on page 8.

If the ENERGY MONITOR or TRIP INFORMATION screen is displayed, touch PAST RECORD.

1. Best past fuel consumption.
2. Update.
The average fuel consumption and graph are updated, and a new average fuel consumption record begins.
3. Average fuel consumption
Displays a maximum of five past records of the average fuel consumption.

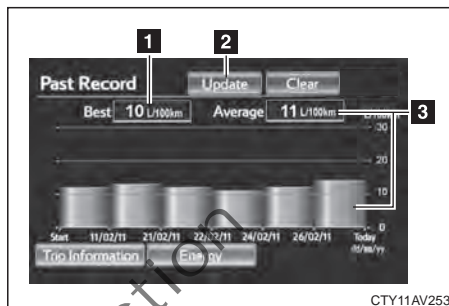

CTY11AV253

The image is an example only and may vary slightly from actual conditions.

Vehicles with Display Audio system –

Press CAR. Refer “Energy monitor” on page 8.

If the ENERGY MONITOR or TRIP INFORMATION screen is displayed, touch PAST RECORD.

1. Best past fuel consumption.
2. Update.
The average fuel consumption and graph are updated, and a new average fuel consumption record begins.
3. Average fuel consumption
Displays a maximum of five past records of the average fuel consumption.

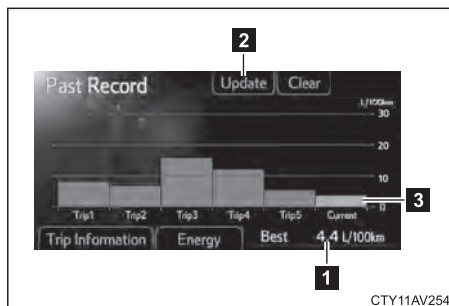

CTY11AV254

The image is an example only and may vary slightly from actual conditions.

Resetting the consumption data

Selecting CLEAR on the TRIP INFORMATION screen will reset the fuel consumption and the regenerated energy for the past 15 minutes. Selecting CLEAR on the PAST RECORD screen will reset the past records and best past fuel consumption. Selecting YES on the following screen will confirm resetting of all the data.

Toyota hybrid system

INFORMATION

For economical and ecological driving, pay attention to the following points.

- Using Eco drive mode
Refer to “Selecting Eco drive mode” on page 88.
- Use of the Hybrid System Indicator
More Eco-friendly driving is possible by keeping the Hybrid System Indicator needle within the Eco area.
- When braking the vehicle
Make sure to operate the brakes gently and in good time. A greater amount of electrical energy can be retained when slowing down.
- Delays
Repeated acceleration and deceleration, as well as long waits at traffic lights, will lead to bad fuel consumption. Check traffic reports before leaving and avoid delays as much as possible. When encountering a delay, gently release the brake pedal to allow the vehicle to move forward slightly while avoiding overuse of the accelerator pedal. Doing so can help control excessive fuel consumption.
- Highway driving
Control your speed and keep at a constant speed. Also, before stopping at a toll booth or similar, allow plenty of time to release the accelerator and gently apply the brakes. A greater amount of electrical energy can be retained when slowing down.
- Air conditioning
Use the air conditioning only when necessary. Doing so can help control excessive fuel consumption.

In summer: In high temperatures, use the recirculated air mode. Doing so will help to reduce the burden on the air conditioning and reduce fuel consumption as well.

In winter: Because the petrol engine will not automatically cut out until the petrol engine and the interior of the vehicle are warm, it will consume fuel. Also, fuel consumption can be improved by avoiding overuse of the heater.
- Checking tire inflation pressure
Check the tyre inflation pressure frequently. Improper tyre inflation pressure can cause poor fuel consumption.

Also, as snow tyres can cause large amounts of friction, their use on dry roads can lead to poor fuel consumption. Use a tyre that is appropriate for the season.
- Luggage
Carrying heavy luggage can lead to poor fuel consumption. Avoid carrying unnecessary luggage. Installing a large roof rack can also cause poor fuel consumption.
- Warming up before driving
Since the petrol engine starts up and cuts out automatically when cold, warming up the engine is unnecessary. Moreover, frequently driving short distances will cause the engine to repeatedly warm up, which can lead to poor fuel consumption.

Key information

KEYS

By carrying the key you can lock or unlock the doors, start the hybrid system or open the boot lid.

1. Electronic keys–
These keys operate the smart entry and start system and include switches for the wireless remote control.
2. Mechanical keys–
These keys can lock or unlock the doors, but cannot start the hybrid system.

To protect items locked in the glove box when using valet parking, remove the mechanical key and leave the electronic key with the attendant.

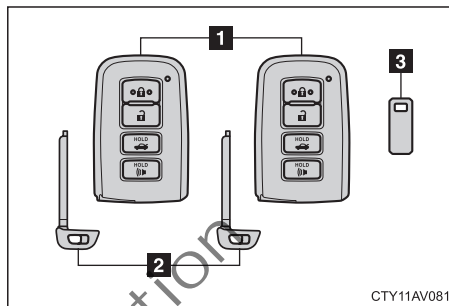

3. Key number plate

The electronic keys contain a transponder chip for the engine immobiliser system. The chip is used to enable the system to function correctly, so be careful not to lose these keys.

⚠ NOTICE

Keys must not be left inside the vehicle as they will continue to communicate with the smart entry and start system.

Using the mechanical key

To remove the mechanical key, push the release button and slide the key out.

- The mechanical key cannot start the hybrid system.
- The mechanical key can only be inserted in one direction. If the key cannot be inserted in a lock cylinder, turn it over and reinsert it.
- After using the mechanical key, always store it in the electronic key.
- If the electronic key battery is discharged or the entry function does not operate correctly, you will need the mechanical key.

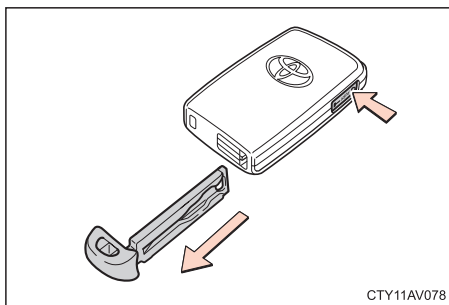

Key information

NOTICE

To prevent key damage

- Do not drop the keys, subject them to strong shocks or bend them.
- Do not expose the keys to high temperatures for long periods of time.
- Do not get the keys wet or wash them in an ultrasonic washer, etc.
- Do not attach metallic or magnetic materials to the keys or place the keys close to such materials.
- Do not disassemble the keys.
- Do not attach a sticker or anything else to the surface of the key.
- Do not place the keys near objects that produce magnetic fields, such as TVs, audio systems and glass top ranges, or medical electrical equipment, such as low-frequency therapy equipment.

Carrying the electronic key on your person

Carry the electronic key 10 cm or more away from electric appliances that are turned on. Radio waves emitted from electric appliances within 10 cm of the electronic key may interfere with the key, causing the key to not function correctly.

In case of a smart entry and start system malfunction or other key-related problems

Take your vehicle with all the electronic keys to your Toyota dealer.

When a vehicle key is lost

If a key is lost, the risk of vehicle theft increases significantly. Take your vehicle with all the electronic keys to your Toyota dealer.

When travelling in an aircraft

When bringing a key with wireless remote control function onto an aircraft, make sure you do not press any buttons on the key while inside the aircraft cabin. If you are carrying the key in your bag, etc., ensure the buttons are not likely to be pressed accidentally. Pressing a button may cause the key to emit radio waves that could interfere with the operation of the aircraft.

Key Number Plate

Your key number is shown on the plate. If you lose your keys or if you need additional keys, duplicates can be made by a Toyota dealer using the key number.

NOTICE

Keep the plate in a safe place and not in the vehicle. Write down the key number and store it in a safe place.

Opening, closing and locking the doors

Opening, closing and locking the doors

WIRELESS REMOTE CONTROL

The wireless remote control is used to lock or unlock the doors, open the boot lid, or sound the alarm system from a distance. Pressing a switch on the remote control performs the following operations.

1. Locks all the doors.
2. Unlocks all the doors.
3. Opens the driver's windows and moon roof – press and hold (This is a customisable feature, refer to "Power windows and moon roof*" on page 343).
4. Opens the boot lid – press and hold.
5. Sounds the alarm – press and hold.

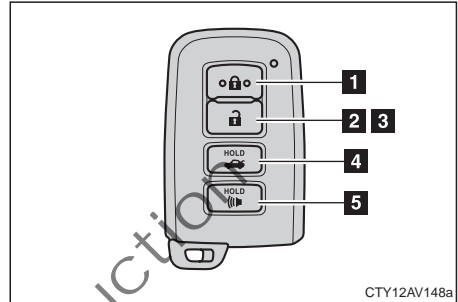

Operation signals

Doors: A buzzer sounds and the turn signal lights flash to indicate the doors have been locked or unlocked. (Locked: Once; Unlocked: Twice)

Boot lid: A buzzer sounds to indicate the boot lid has been opened.

Door lock buzzer: If an attempt to lock the doors is made when a door is not fully closed, a buzzer sounds continuously. Fully close the door to stop the buzzer, and lock the vehicle once more.

Panic mode

When  is pressed for longer than one second, an alarm will sound intermittently and the turn signal lights will flash to deter any person from trying to break into or damage your vehicle.

To stop the alarm, press any button on the wireless remote control.



Security feature

If a door is not opened within approximately 30 seconds after the vehicle has been unlocked, the security feature will automatically lock the vehicle again.

Opening, closing and locking the doors

NOTICE

Conditions that can affect operation

The wireless remote control may not operate normally in the following situations:

- When the wireless key battery is discharged
- Near a TV tower, electric power plant, petrol station, radio station, large display, airport or other facility that generates strong radio waves or electrical noise
- When carrying a portable radio, mobile phone or other wireless communication devices
- When the wireless key is in contact with, or is covered by a metallic object
- When another wireless key (that emits radio waves) is being used nearby
- If window tint with a metallic content or metallic objects are attached to the rear window

Refer to “Conditions that can affect operation” on page 25.

Key battery depletion

If the wireless remote control function does not operate, the battery may be discharged. This is usually indicated by the range of the wireless remote control becoming shorter and / or the LED on the key not illuminating when a switch is pressed. Replace the battery when required, refer to “Replacing the remote control transmitter battery” on page 303.

Customisable features that can be modified

For further information refer to “Customisable features” on page 339.

Opening, closing and locking the doors

SMART ENTRY AND START SYSTEM

The following operations can be performed simply by carrying the electronic key in your pocket, for example. It is recommended the driver always carry the electronic key.

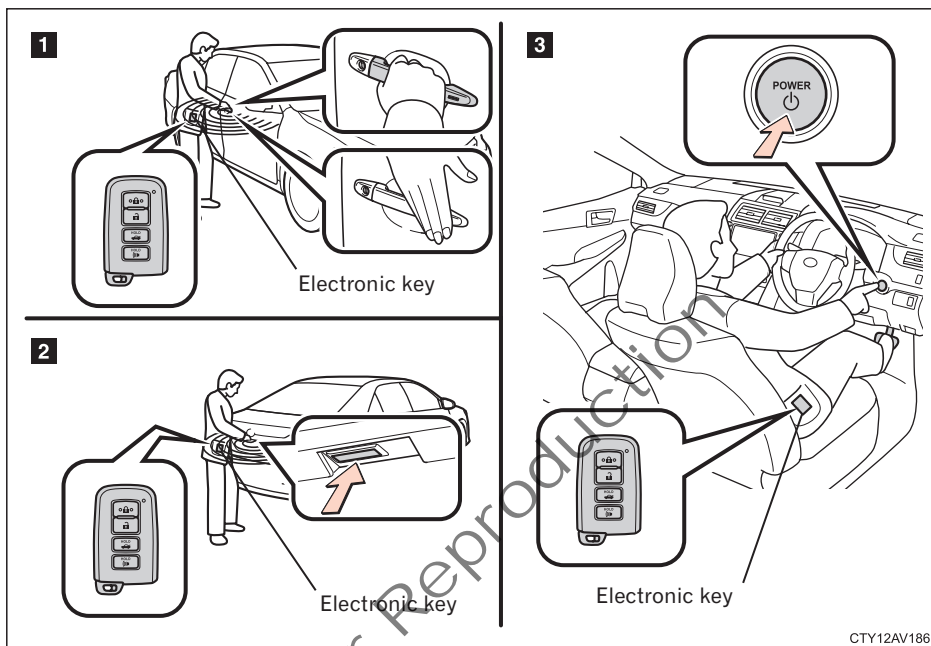

1	Locks and unlocks all the doors.
2	Opens the boot lid.
3	Unlocks the steering wheel and starts the hybrid system. For further information, refer to "Power (ignition) switch" on page 78 and "Starting the hybrid system" on page 79.

⚠ CAUTION

- People with implanted pacemakers or cardiac defibrillators should keep away from smart entry and start system antennas. This is because the radio waves may affect the operation of such devices. Refer to "Antenna location" on page 21.
- Users of any electrical medical device other than implanted pacemakers and cardiac defibrillators should consult the manufacturer of the device for information about its operation under the influence of radio waves. This is because the radio waves could have unexpected affects on the operation of such medical devices.
- If necessary, the entry function can be disabled. Refer to "Customisable features" on page 339.

Opening, closing and locking the doors

Unlocking and locking the doors

Grip the driver's or front passenger's door handle to unlock all doors.

- Make sure the sensor on the back of the handle is touched.
- After the doors have been locked, they cannot be unlocked for 3 seconds.

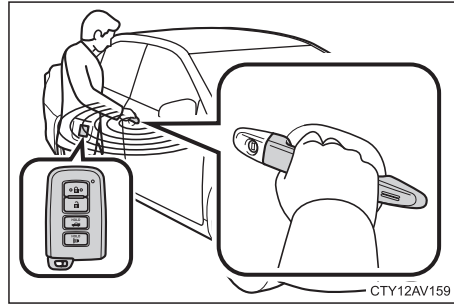

Touch the lock sensor (the indentation on the side of the door handle) to lock all doors.

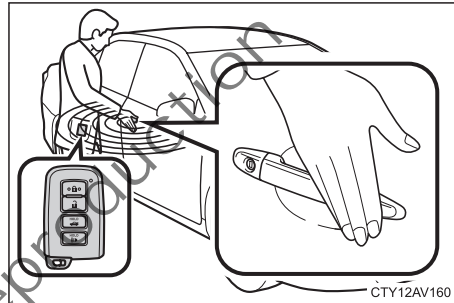

Opening the boot lid

Press the button to open the boot lid.

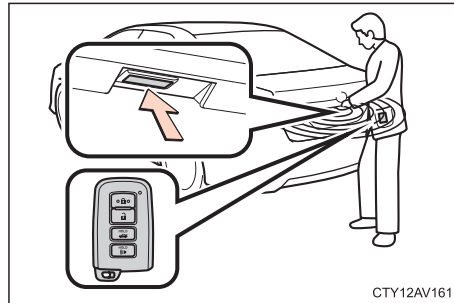

Opening, closing and locking the doors

Antenna location

The following antennas are used to detect the electronic key and allow operation of the smart entry and start system.

1. Antennas outside the cabin.
2. Antenna outside the boot lid.
3. Antenna inside the boot lid.
4. Antennas inside the cabin.

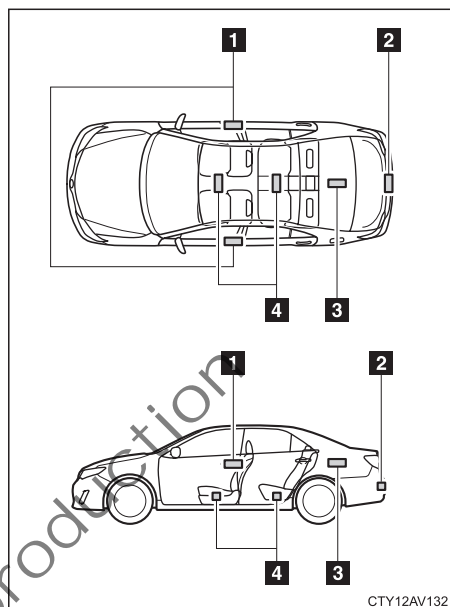

Effective range

The smart entry and start system will detect the electronic key within the following areas.

- When locking or unlocking the doors.

The system can be operated when the electronic key is within about 0.7 m of either front outside door handle. (Only the door detecting the key can be operated.)

- When unlocking the boot lid.

The system can be operated when the electronic key is within about 0.7 m of the boot lid release button.

- When starting the hybrid system or changing POWER switch button modes.

The system can be operated when the electronic key is inside the vehicle.

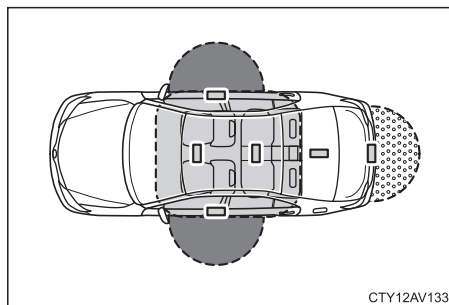

Operation signals

Doors: A buzzer sounds and the turn signal lights flash to indicate the doors have been locked or unlocked. (Locked: once; Unlocked: twice)

Boot lid: A buzzer sounds to indicate the boot lid has been opened.

Opening, closing and locking the doors

When the door cannot be locked by the lock sensor

Use your palm to touch the lock sensor.

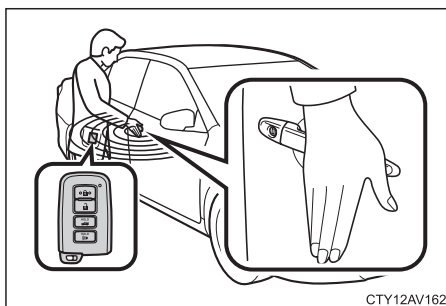

NOTICE

Consult your Toyota dealer if the smart entry and start system does not operate correctly because of a system malfunction. Bring all of the keys as they may be required to repair the system.

Security feature

If a door is not opened within approximately 30 seconds after the vehicle has been unlocked, the security feature automatically locks the vehicle again. However, depending on the location of the electronic key, the key may be detected as being in the vehicle. In this case, the vehicle may be unlocked.

When the vehicle is not driven for extended periods

To prevent theft of the vehicle, do not leave the electronic key within 2 metres of the vehicle. When the key is within this range the door locks can be operated by anyone. The smart entry and start system has a battery-saving function, refer to “Battery-saving function” on page 24, or it can be deactivated through customisation, refer to “Customisable features” on page 339.

To operate the system properly

When operating the smart entry and start system, always carry the electronic key in your pocket or purse, for example.

When operating the system from outside of the vehicle, do not place the electronic key too close to the vehicle or a window.

If the electronic key is held in an incorrect position or direction relative to the vehicle then it may not be detected correctly by the vehicle. In this case, the system may not operate properly. (The alarm may go off accidentally, or the door lock prevention function may not operate.)

Alarms and warning lights

A combination of exterior and interior alarms as well as warning messages shown on the multi-information display are used to prevent theft of the vehicle and unforeseeable accidents resulting from erroneous operation. Take appropriate measures in response to any warning message on the multi-information display. For further information, refer to “Warning messages” on page 100.

Opening, closing and locking the doors

The following table describes circumstances and correction procedures when exterior or interior alarms are sounded.

Alarm	Situation	Correction
Exterior alarm sounds once for 5 seconds	The boot lid was closed while the electronic key was still inside the boot and all the doors were locked	Retrieve the electronic key from the boot and close the boot lid
	An attempt was made to lock the vehicle while a door was open	Close all doors and lock the doors again
Interior alarm sounds continuously	The POWER switch was pressed to ACCESSORY mode while the driver's door was open. Or the driver's door was opened while the POWER switch was in ACCESSORY mode	Press the POWER switch off and close the driver's door

Electronic key battery depletion

The standard life of the electronic key battery is one to two years.

If the battery becomes discharged, an alarm will sound in the cabin when the hybrid system is stopped.

As the electronic key is always receiving radio waves, the battery will become discharged even if the electronic key is not used. The following symptoms indicate the electronic key battery may be discharged. Replace the battery when necessary.

- The smart entry and start system or the wireless remote control does not operate.
- The detection area becomes smaller.
- The LED indicator on the key does not illuminate.

To avoid serious deterioration, do not leave the electronic key within 1 metre of the following electrical appliances that produce a magnetic field:

- TVs
- Personal computers
- Mobile phones, cordless phones and battery chargers
- Glass top stoves
- Table lamps

When the electronic key battery is fully discharged replace the battery. Refer to "Replacing the remote control transmitter battery" on page 303.

Opening, closing and locking the doors

Battery-saving function

The battery-saving function will be activated in order to prevent the electronic key battery and the vehicle's 12-volt auxiliary battery from being discharged while the vehicle is not in operation for an extended time.

In the following situations, the smart entry and start system may take some time to unlock the doors.



- The electronic key has been left within an area approximately 2 metres from outside of the vehicle for 10 minutes or longer.
- The smart entry and start system has not been used for five days or longer.

If the smart entry and start system has not been used for 14 days or longer, the doors can only be unlocked from the driver's door.

In this case, grasp the driver's door handle, use the wireless remote control or use the mechanical key to unlock the doors.

Electronic key battery-saving function

When battery-saving mode is set, battery depletion is minimised by stopping the electronic key from receiving radio waves.

1. Press  twice while pressing and holding .
2. Confirm the electronic key indicator flashes four times.

While the battery-saving mode is set, the smart entry and start system cannot be used. To cancel the function, press any of the electronic key switches.

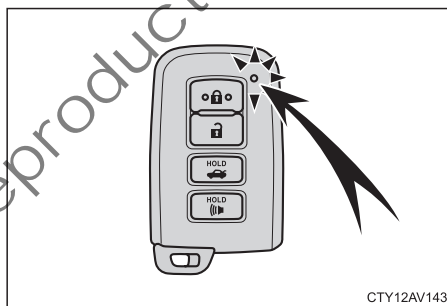

Function to prevent the electronic key being locked in the boot

When all doors are locked, closing the boot lid while the electronic key is inside the boot will sound an alarm. In this case, the boot lid can be reopened using the entry function.

NOTICE

- If a spare electronic key is in the boot and all the doors are then locked, the boot lid can still be opened using the entry function.
To prevent theft, always take all electronic keys with you when leaving the vehicle.
- In some instances if an electronic key is put in the boot while all doors are locked, the key may not be detected. This will depend upon where the key is placed and the surrounding radio wave conditions.
In this case, the key confinement prevention function will not be activated, causing the doors to lock when the boot lid is closed. Always check where the key is before closing the boot lid.
- The key confinement prevention function will not be activated if any door is unlocked. In this case, open the boot lid using the opener.

 NOTICE**Conditions that can affect operation**

The smart entry and start system uses weak radio waves. In the following situations, communication between the electronic key and the vehicle may be affected, preventing the smart entry and start system, wireless remote control and engine immobiliser system from operating normally.

- When the electronic key battery is discharged.
- Near a TV tower, electric power plant, petrol station, radio station, large display, airport or other facility that generates strong radio waves or electrical noise.
- When the electronic key is in contact with, or is covered by the following metallic objects:
 - Cards to which aluminium foil is attached
 - Cigarette boxes that have aluminium foil inside
 - Metallic wallets or bags
 - Coins
 - Hand warmers made of metal
 - Media such as CDs and DVDs
- When another wireless key (that emits radio waves) is being used nearby.
- When carrying the electronic key together with the following devices that emit radio waves:
 - A portable radio, mobile phone, cordless phone or other wireless communication devices
 - Another vehicle's electronic key or a wireless key that emits radio waves
 - Personal computers or personal digital assistants (PDAs)
 - Digital audio players
 - Portable game systems
- If window tint with a metallic content or metallic objects are attached to the rear window.
- When the electronic key is placed near a battery charger or electronic devices.

Opening, closing and locking the doors

NOTICE

Notes for the entry function

- Even when the electronic key is within the effective range (detection areas), the system may not operate properly in the following cases:
 - The electronic key is too close to a window or an outside door handle, near the ground, or too high when the doors are locked or unlocked
 - The electronic key is near the ground or too high, or too close to the centre of the rear bumper when the boot lid is unlocked
 - The electronic key is on the instrument panel, rear package tray or floor, or in the door pockets or glove box when the hybrid system is started or POWER switch modes are changed
- Do not leave the electronic key on top of the instrument panel or near the door pockets when exiting the vehicle. Depending on the radio wave reception conditions, it may be detected by the antenna outside the cabin and the door will become lockable from the outside, possibly trapping the electronic key inside the vehicle.
- As long as the electronic key is within the effective range, the doors may be locked or unlocked by anyone.
- Even if the electronic key is not inside the vehicle, it may be possible to start the hybrid system if the electronic key is near the window.
- The doors may unlock if a large amount of water splashes on the door handle, such as in the rain or in a car wash when the electronic key is within the effective range. (The doors will be automatically locked after approximately 30 seconds if the doors are not opened and closed.)
- Gripping the door handle when wearing a glove may not unlock the door.
- If the wireless remote control is used to lock the doors when the electronic key is near the vehicle, there is a possibility the door may not be unlocked by the entry function. (Use the wireless remote control to unlock the doors.)
- A sudden approach to the effective range or door handle may prevent the doors from being unlocked. In this case, return the door handle to the original position and check the doors unlock before pulling the door handle again.

Opening, closing and locking the doors

NOTICE

When locking the doors

- Touching the door lock sensor while wearing gloves may delay or prevent lock operation. Remove the gloves and touch the lock sensor again.
- When the lock operation is performed using the lock sensor, recognition signals will be shown up to two consecutive times. After this, no recognition signals will be given.
- When washing the vehicle, for example, if a front door handle is sprayed with a strong jet of water while the electronic key is within the effective range outside the vehicle, the door may lock and unlock repeatedly. In that case:
 - Place the electronic key in a safe location 2 metres or more from the vehicle
 - Set the electronic key to battery-saving mode to disable the smart entry and start system
- If the electronic key is inside the vehicle and a front door handle is sprayed with a strong jet of water during a car wash, a buzzer may sound outside the vehicle. To turn off the alarm, lock all the doors.
- The lock sensor may not work properly if it comes into contact with ice, snow or mud, etc. Clean the lock sensor and attempt to operate it again.

When unlocking the doors

- A sudden approach to the effective range outside the vehicle or front door handle may prevent the doors from being unlocked. In this case, return the door handle to the original position and check the doors unlock before pulling the door handle again.
- Gripping the door handle when wearing a glove may not unlock the door. Remove the glove and touch the sensor on the back of the handle again.
- When washing the vehicle, for example, if a front door handle is sprayed with a strong jet of water while the electronic key is within the effective range outside the vehicle, the door may lock and unlock repeatedly. In that case:
 - Place the electronic key in a safe location 2 metres or more from the vehicle
 - Set the electronic key to battery-saving mode to disable the smart entry and start system, refer to “Battery-saving function” on page 24
- If there is another electronic key in the detection area, it may take slightly longer to unlock the doors after the door handle is gripped.

Customisable features that can be modified

For further information refer to “Customisable features” on page 339.

Opening, closing and locking the doors

DOORS

The doors can be locked and unlocked in the following ways.

Locking and unlocking with wireless door control

Pressing a switch on the key performs a wireless remote control operation such as locking or unlocking the doors, opening the boot lid, or sounding the alarm. For further details refer to “Wireless remote control” on page 17.

Locking and unlocking with smart entry and start system

When you carry the electronic key into the activation area, you can lock and unlock the doors by grasping or touching a front door handle. For further information, refer to “Smart entry and start system” on page 19.

Locking and unlocking with the key

Insert the mechanical key into the driver’s door handle keyhole and turn it.

1. To unlock:
Turn the key rearward.
2. To lock:
Turn the key forward.

All the doors lock or unlock simultaneously with the driver’s door*.

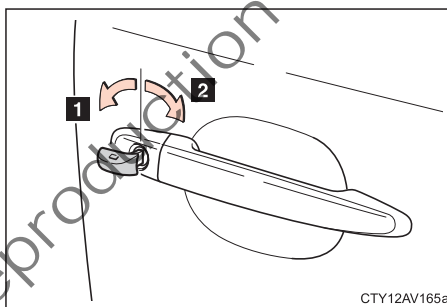

* These settings can be modified, for further information refer to “Customisable features” on page 339.

If an incorrect key is used, the key cylinder rotates freely to isolate the inside mechanism.

When you unlock the doors, the illuminated entry system will be activated. For further information, refer to “Illuminated entry system” on page 240.

Locking and unlocking with the door lock switch

All the doors lock or unlock simultaneously.

1. To lock:
Press the switch down on the right side.
2. To unlock:
Press the switch down on the left side.

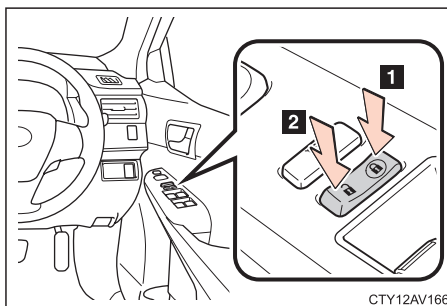

Opening, closing and locking the doors

Locking and unlocking with the inside lock button

Each door can be locked or unlocked.

1. To unlock:
Pull the button backward.
2. To lock:
Push the button forward.

The driver's door can be opened by pulling the inside door handle even if the lock button is in the lock position.

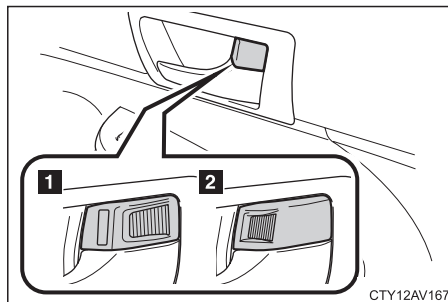

Locking the front doors from the outside without a key

1. Move the inside lock button to the lock position.
2. Close the door while pulling the door handle.

The door cannot be locked if the POWER switch is in ACCESSORY or ON mode, or the electronic key is left inside the vehicle.

If the electronic key is left inside the vehicle, there is a chance the key may not be detected correctly and the door may be locked.

Impact detection door lock release system

If the vehicle is subject to a strong impact, all the doors are automatically unlocked.

Depending on the force of the impact or the type of accident, however, the system may not always operate.

Customisable features that can be modified

For further information refer to "Customisable features" on page 339.

Opening, closing and locking the doors

Rear door child-protector lock

When the child-protector switch is in the Lock position, the rear door cannot be opened by the inside door handle. The door can be opened normally from outside the vehicle.

1. Unlock.
2. Lock.

NOTICE

To avoid an accident, Toyota recommends the rear door child-protector lock feature is used whenever small children are in the vehicle.



CAUTION

Observe the following precautions while driving the vehicle. Failure to do so may result in a door opening and an occupant falling out, resulting in death or serious injury.

- Always wear a seatbelt and ensure it is correctly adjusted.
- Ensure all doors are properly closed.
- Always lock all the doors.
- Do not pull the inside handle of the doors while driving. The door may open and an occupant fall out resulting in serious injury or death.
- Be especially careful for the driver's door, as the door can be opened even if the inside lock button is in the Lock position.
- Set the rear door child-protector locks when children are seated in the rear seats.

Opening, closing and locking the doors

BOOT LID

CAUTION

Boot lid precautions

- Ensure the boot lid is closed before driving. If the boot lid is left open, it may hit nearby objects while driving or luggage in the boot may be unexpectedly thrown out and cause an accident. Keeping the boot lid closed also prevents exhaust gases from entering the vehicle.
- Before driving the vehicle, make sure the boot lid is fully closed. If the boot lid is not fully closed, it may open unexpectedly while driving, causing an accident.
- Never let anyone sit in the boot. In the event of sudden braking or a collision, they are susceptible to death or serious injury.
- When children are in the vehicle, observe the following precautions. Failure to do so may result in death or serious injury:
 - Do not allow children to enter the boot. If a child is accidentally locked in the boot, they could overheat or suffocate.
 - Do not allow a child to open or close the boot lid. Doing so may cause the boot lid to operate unexpectedly, or cause the child's hands, head, or neck to be caught by the closing boot lid.

Opening the boot lid

The boot lid can be opened in the following ways.

With wireless door control–

Pressing the  switch on the key for more than 1 second performs a wireless remote control operation to open the boot lid. For further details refer to "Wireless remote control" on page 17.

With smart entry and start system–

When you carry the electronic key into the activation area, you can open the boot lid. For further information, refer to "Smart entry and start system" on page 19.

From inside the vehicle–

Lift the lever to open the boot lid.

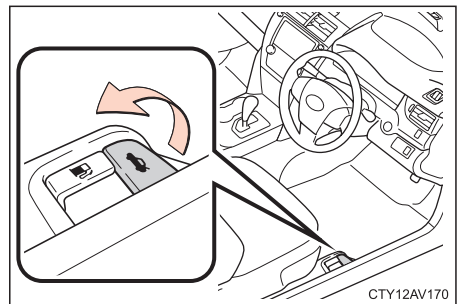

CTY12AV170

Opening, closing and locking the doors

To close the boot lid

Lower the boot firmly in the one action. Once it is closed, try pulling it up to make sure it is securely closed.

Boot illumination

The boot light turns on automatically when the boot lid is opened.

CAUTION

When using the boot, observe the following precautions. Failure to do so may cause parts of the body to be caught, resulting in serious injury.

- Remove any heavy loads, such as snow and ice, from the boot lid before opening it. Failure to do so may cause the boot lid to fall closed again after it is opened.
- When opening or closing the boot lid, thoroughly check to make sure the surrounding area is safe.
- If anyone is in the vicinity, make sure they are safe and let them know the boot is about to open or close.
- Use caution when opening or closing the boot lid in windy weather as it may move abruptly in strong wind.
- The boot lid may fall if it is not opened fully. It is more difficult to open or close the boot lid on an incline than on a level surface, so beware of the boot lid unexpectedly opening or closing by itself. Make sure the boot lid is fully open and secure before using the boot.
- When closing the boot lid, take extra care to prevent your fingers etc. from being caught.
- When closing the boot lid, press it lightly on its outer surface. If the handle is used to fully close the boot lid, it may result in hands or arms being caught.
- Do not attach any accessories other than genuine Toyota parts to the boot lid. Such additional weight on the boot lid may cause the lid to fall closed again after it is opened.

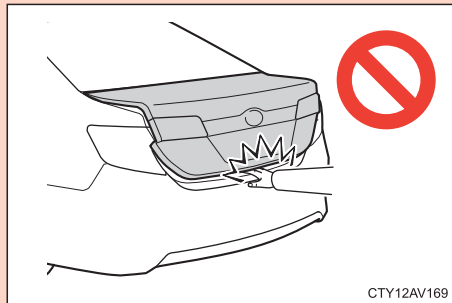
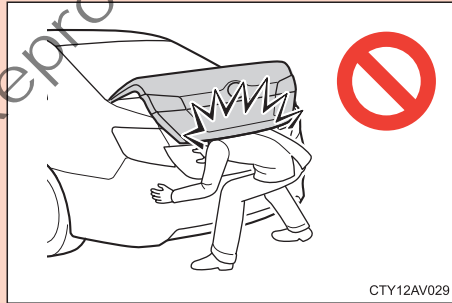

Adjustable components

SEATS

While the vehicle is being driven, all vehicle occupants should have the seatback upright, sit well back in the seat and correctly wear the seatbelts provided.

CAUTION

- Persons not correctly seated and/or not correctly restrained by seatbelts can be killed or severely injured in the event of emergency braking or a collision.
- Do not drive the vehicle unless the occupants are correctly seated.
- Do not allow any passenger to sit on top of a folded-down seatback, or in the luggage compartment or cargo area.

FRONT SEATS

CAUTION

Driver's seat precautions

- The SRS driver airbag deploys with considerable force and can cause death or serious injury, especially if the driver is very close to the airbag.
- The driver airbag risk zone is the first 50-75 mm of inflation. Therefore, remaining 250 mm from your driver airbag will minimise your risk of sustaining injuries when the airbag inflates. This distance is measured from the centre of the steering wheel to your breastbone. If you sit less than 250 mm away from the driver airbag, consider changing your driving position in the following ways:
 - Move your seat backwards as far as you can while still reaching the pedals comfortably
 - Slightly recline the back of your seat. If reclining the back of the seat impedes your view of the road, raise your seat if your vehicle has that feature
 - Adjust your steering wheel downwards slightly. This will point the airbag toward your chest instead of at your head and neck
 - Always ensure that you maintain control of the foot pedals and steering wheel and that you maintain your view of the instrument panel controls and the road

Front passenger's seat precautions

- The SRS front passenger airbag also deploys with considerable force and can cause death or serious injury, especially if the passenger is very close to the airbag.
- To minimise the risk of sustaining injuries when the airbag inflates, the front passenger seat should be as far from the airbag as possible, with the seatback adjusted so the front passenger sits upright.

Adjustable components

CAUTION

Front seats with SRS side airbags

SRS side airbags are installed in the driver's and front passenger's seats.

Observe the following precautions.

- Do not lean against the front doors when the vehicle is in use. The side airbags inflate with considerable speed and force and you may be killed or seriously injured if your body is in contact with them during inflation.
- Do not use seat accessories which cover the area where the side airbags inflate. Such accessories may prevent the side airbags from activating correctly, causing death or serious injury.
- Do not modify or replace the seats or upholstery of the seats equipped with side airbags. Such changes may prevent the side airbag system from activating correctly, disable the system or cause the side airbags to inflate accidentally, resulting in death or serious injury.

CAUTION

Seat adjustment precautions

- Do not adjust the seat while the vehicle is moving as the seat may unexpectedly move and cause the driver to lose control of the vehicle.
- Be careful the seat does not hit a passenger or luggage.
- After adjusting the seat position, release the lever and try sliding the seat forward and backward to make sure it is locked in position.
- After adjusting the seat back, push your body back against the seat to make sure the seat is locked in position.
- Do not put objects under the seats. Objects placed under seats may interfere with the seat-lock mechanism or unexpectedly operate the seat position adjusting lever and the seat may suddenly move, causing the driver to lose control of the vehicle.
- While adjusting the seat, do not put your hands under the seat or near the moving parts. Otherwise, your hands or fingers may be caught and injured.

Adjusting front seats (power seat)

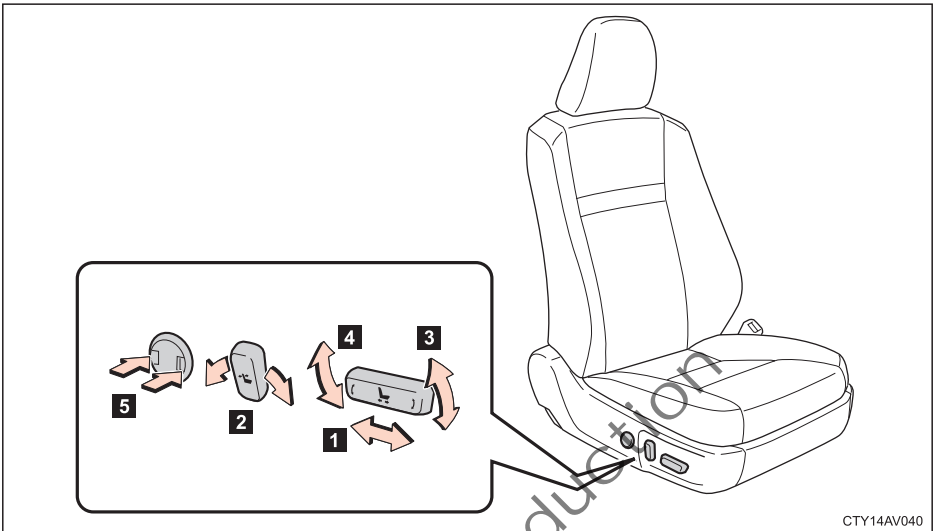

CTY14AV040

For driver's and front passenger's seat–

1. Seat position adjustment switch:
Move the switch in the direction of the arrow to move the seat forwards or backwards.
2. Seatback angle adjusting switch:
Move the switch in the direction of the arrows to adjust the seatback angle.

For driver's seat only–

3. Seat height adjustment switch, front:
Move the switch in the direction of the arrow to raise or lower the front of the seat cushion.
4. Seat height adjustment switch, rear:
Move the switch in the direction of the arrow to raise or lower the rear of the seat cushion.
5. Seat lumbar support adjusting switch:
Push the front of the switch to increase the amount of support, or push the rear of the switch to decrease the amount of support.
The amount of lumbar support will change while the switch is pushed.

Adjustable components

Adjusting passenger seat (manual seat)

For front passenger's seat–

1. Seat position adjusting lever:
Hold the centre of the lever and pull it up. Then slide the seat to the desired position with slight body pressure and release the lever.
2. Seatback angle adjusting lever:
Lean forward and pull the lever up. Then lean back to the desired angle and release the lever.

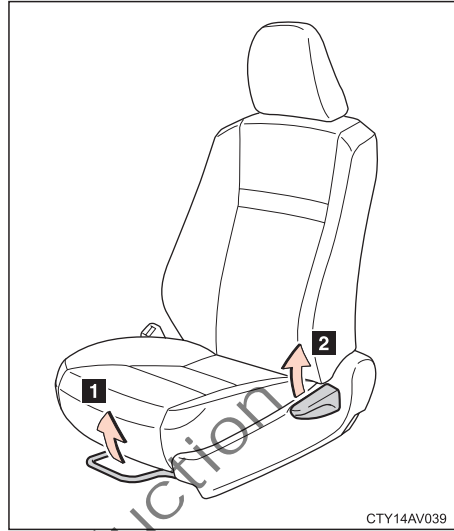

⚠ CAUTION

- Do not recline the seatback any more than needed. In a frontal collision, the more the seat is reclined, the greater the risk of death or serious injury.
- After adjusting the manual seat, ensure the seat is locked in position.
- Seatbelts provide maximum protection in a frontal or rear collision when the driver and passengers are sitting up straight and well back in their seats. If you are reclined, the lap belt may slide past your hips and apply forces directly to the abdomen or your neck may contact the shoulder belt increasing the risk of death or serious injury.
- Refer to "Front seats" on page 33 regarding the recommended distance between the driver and front passengers seats and the SRS airbag.

FRONT HEAD RESTRAINTS

For your safety and comfort, adjust the head restraints before driving.

1. To raise–
Pull the head restraint up.
2. To lower–
Press the lock release button and
Push the head restraint down.

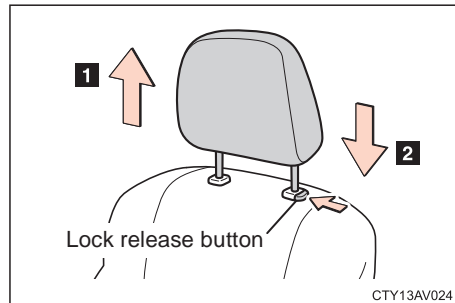

Adjustable components

- Adjust the head restraint so the centre of the head restraint is closest to the top of your ears.

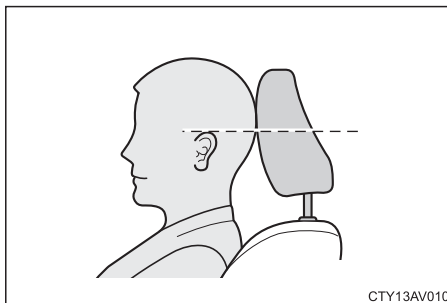

- To remove the front head restraint, pull it up while pushing the lock release button.

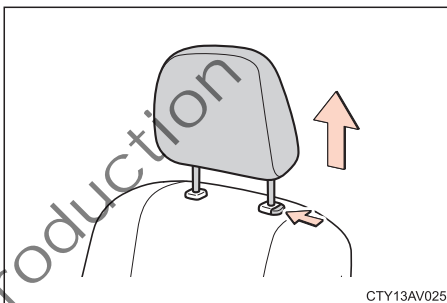

CAUTION

Observe the following precautions regarding the head restraints. Failure to do so may result in death or serious injury.

- Use the head restraints designed for each respective seat.
- Adjust the head restraints to the correct position at all times.
- After adjusting a head restraint, push it down to ensure it is locked in position.
- Do not drive with the head restraints removed.

Adjustable components

DRIVING POSITION MEMORY SYSTEM

This system can memorise the preferred position of the driver's seat and outside rear view mirrors, and recall them at the touch of a button. Two different driving positions can be entered.

Setting the driving position

1. Press the POWER switch to ON mode.
2. Move the shift lever to the P position.
3. Adjust the driver's seat and outside rear view mirrors to the desired position.
4. While pressing the SET button, press memory button 1 or 2 until a beep is heard.

A second position can be memorised by repeating the above steps and using the alternate memory button.

If step 4 is performed when both memory buttons contain a memorised position, the previous position will be overwritten.

To make only slight changes to an already memorised position, the easiest way is to first activate the memorised position, then make the desired changes and perform step 4 above.

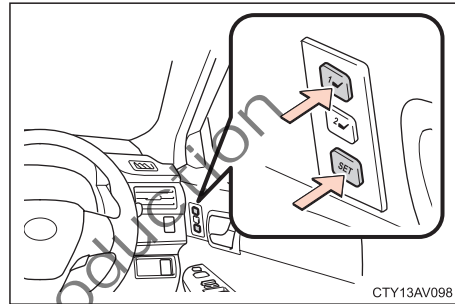

Recalling the memorised position

The memorised position can be recalled under the following conditions:

1. Press the POWER switch to ON mode.
2. Move the shift lever to the P position.
3. Press memory button 1 or 2.

The driving position will be automatically adjusted to the position recorded for that button.

- To stop the operation, press any driving position memory button.
- If the vehicle's battery is disconnected, the memory will be erased and the positions will have to be set again.
- Memorised positions can be activated up to 3 minutes after the driver's door is opened and another 60 seconds after it is closed again, even after pressing the POWER switch OFF.

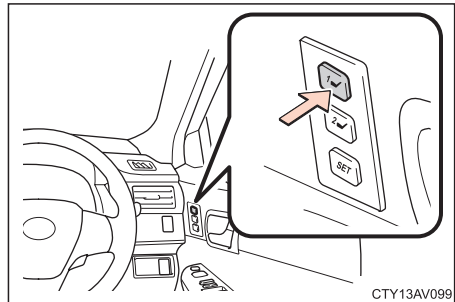

⚠ CAUTION

- Do not start the vehicle while the adjustments are being made.
- Take care not to select the wrong button, or the seat could strike the rear passenger or force your body against the steering wheel.
- If this happens, you can stop the movement by pressing any driving position memory button.

Driving position memory system using the electronic key

The memorised positions can be linked to the electronic key when an unlock operation is performed using the wireless remote control or the entry function of the smart entry and start system.

Linking the driving position to the electronic key–

1. Set the driving position to memory buttons 1 or 2 as previously described.
2. Carry the key to which you want to link the driving position.
NOTE: If another key is in the vehicle the linking operation cannot be performed.
3. Press the POWER switch to OFF.
4. Close the driver's door.
5. While pressing the desired memory button (1 or 2), press the driver's door lock or unlock switch until a beep is heard.

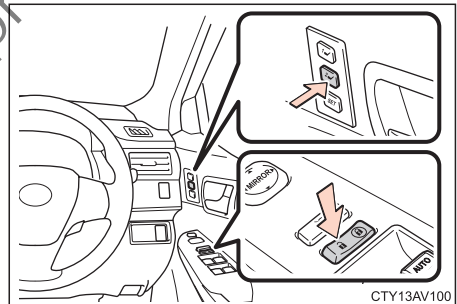

Cancelling driving position linking–

1. Press the POWER switch to OFF.
2. Close the driver's door.
3. While pressing the SET button, press the driver's door lock or unlock switch until a beep is heard.

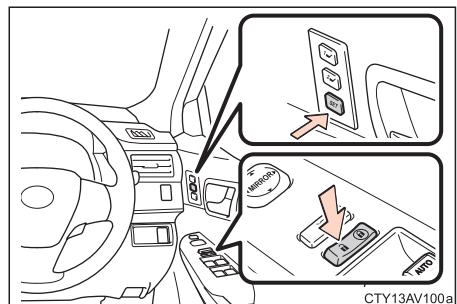

Adjustable components

REAR SEATS

Armrest

To use the armrest, pull it down as shown.

NOTICE

To prevent damage to the armrest, do not apply too much load.

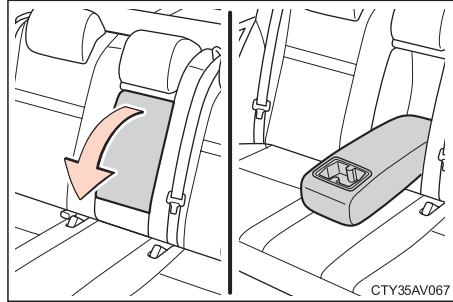

Fold-down rear seat

1. To unlock the seatback, pull the lever in the boot.

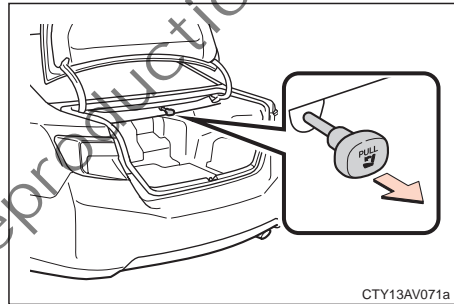

2. Fold down the seatback.
 - The right hand seatback can be folded down.
 - This will enlarge the boot as far as the front seatbacks.

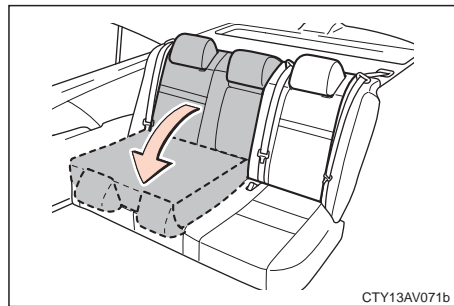

⚠ CAUTION**When folding the rear seatbacks down**

Observe the following precautions. Failure to do so may result in death or serious injury.

- Do not fold the seatbacks down while driving.
- Stop the vehicle on level ground, set the parking brake and move the shift lever to P position.
- Do not allow anyone to sit on a folded seatback or in the boot while driving.
- Do not allow children to enter the boot.

When returning the seat to its original position

- Ensure the seatbelt does not get caught between or behind the seats.
- If the seatbelt has been released from its guide, pass the seatbelt back through the guide. Refer to "Rear seatbelt guide" on page 45.

Seat adjustment

Be careful not to get hands or feet pinched between the rear console box and the rear seat when folding down the rear seatback.

After returning the seatback to the upright position

Observe the following precautions. Failure to do so may result in death or serious injury.

- Make sure the seatback is securely locked by pressing forward and rearward on the top.
- Check the seatbelts are not twisted or caught in the seatback.
- Ensure the seatbelt is passing through its guide.

SEATBELTS**Seatbelt precautions**

The seatbelts provided for your vehicle are designed for people of adult size, large enough to correctly wear them.

⚠ CAUTION**General**

- Toyota recommends that the driver and all passengers must wear seatbelts whenever the vehicle is moving. Otherwise, they are much more likely to suffer serious bodily injury or death during sudden braking or a collision.
- When wearing a seatbelt, always observe the following:
 - Each person must wear a separate seatbelt
 - Do not recline the seatback any more than needed. In a frontal collision, the more the seat is reclined, the greater the risk of death or serious injury
 - Seatbelts provide maximum protection in a frontal or rear collision when the driver and passengers are sitting up straight and well back in their seats. If you are reclined, the lap belt may slide past your hips and apply forces directly to the abdomen, or your neck may contact the shoulder belt

Adjustable components

! CAUTION

People with special needs

Pregnant woman:

- Toyota recommends the use of a seatbelt. Ask your doctor for specific recommendations.
- The lap belt should be worn securely and as low as possible over the hips and not on the waist.

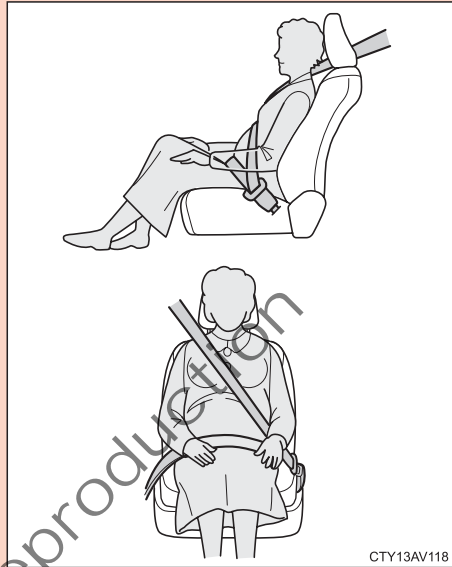

Children:

- An appropriate child restraint system must be used for all children until they reach a certain age or weight. The precise legal requirements are different in the various States and Territories so you should consult your local laws. Also refer to "Child restraint system" on page 74.
- Some States and Territories have laws governing where a child is permitted to sit in vehicles so you should consult your local laws.
- If a child is too large for a child restraint system, the child should sit in the rear seat and must be restrained using the vehicle's seatbelt. According to accident statistics, the child is safer when correctly restrained in the rear seat than in the front seat.
- If a child must sit in the front seat, the seatbelts should be worn correctly. If an accident occurs and the seatbelts are not worn correctly, the force of the rapid inflation of the airbag may cause death or serious injury to the child.
- Do not allow a child to stand up or kneel on either rear or front seats. An unrestrained child could suffer serious injury or death during emergency braking or a collision. Also, do not let the child sit on your lap. Holding a child in your arms does not provide sufficient restraint.

Injured person:

- Toyota strongly recommends the use of a seatbelt. Depending on the injury, first check with your doctor for specific recommendations.

! CAUTION

Positioning of seatbelts

- Seatbelts are designed to bear upon the bony structure of the body. Position the belt low across the front of the pelvis and over the shoulder so it does not contact the neck or slide off.
- Wearing the lap section of the belt across the abdominal area must be avoided.



- Seatbelts should be adjusted as firmly as possible, consistent with comfort, to provide the protection for which they have been designed. A slack belt will greatly reduce the protection afforded to the wearer.
- Both high positioned lap belts and loose fitting belts could cause serious injuries due to sliding under the lap belt during a collision or other unintended event. Keep the lap belt positioned as low on hips as possible.
- Do not place the shoulder belt under your arm.
- Belts should not be worn with straps twisted.
- **WARNING:** No modifications or additions should be made by the user which will either prevent the seatbelt adjusting devices from operating to remove slack, or prevent the seatbelt assembly from being adjusted to remove slack.

! CAUTION

Care and maintenance of seatbelts

- Be careful not to damage the belt webbing or hardware. Always take care they do not get caught or pinched in the seat or doors.
- Inspect the belt system periodically. Check for cuts, fraying, and loose parts. Damaged parts should be replaced. Do not disassemble or modify the system.
- Keep the belts clean and dry. If they need cleaning, use a mild soap solution of lukewarm water. Never use bleach, dye, or abrasive cleaners, or allow them to come into contact with the belts as they may severely weaken the belts. For further information refer to "Seatbelts" on page 258.
- Replace the belt assembly (including bolts) if it has been used in a severe impact. The entire assembly should be replaced even if damage is not obvious. To ensure correct replacement and operations your Toyota dealer should undertake this installation.
- Care should be taken to avoid contamination of the webbing with polishes, oils and chemicals, and particularly battery acid.

Adjustable components

! CAUTION

- Cleaning may safely be carried out using mild soap and water.
- The belt should be replaced if webbing becomes frayed, contaminated or damaged.
- Each belt assembly must only be used by one occupant; it is dangerous to put a belt around a child being carried on the occupant's lap.

Fastening and releasing the seatbelt

Adjust the seat as required and sit up straight and well back in the seat.

1. To fasten the seatbelt, pull it out of the retractor smoothly and insert the tab into the buckle.

You will hear a click when the tab locks into the buckle.

2. To release the seatbelt, press the release button.

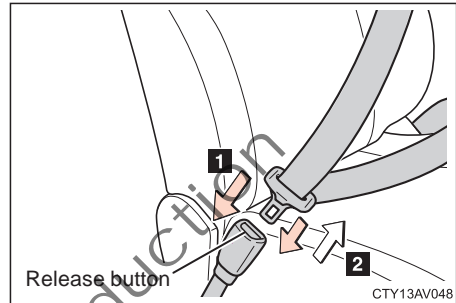

! CAUTION

- To avoid serious injury or death, you must immediately contact your Toyota dealer if your seatbelt does not function normally. Do not use the seat until the seatbelt is fixed.
- After inserting the tab, make sure the tab and buckle are locked and the belt is not twisted.
- Do not insert coins, clips, etc. into the buckle as this may prevent you from correctly latching the tab and buckle.

Emergency locking retractor (ELR)

The retractor will lock the belt during a sudden stop or on impact. It also may lock if you lean forward too quickly. A slow, easy motion will allow the belt to extend, and you can move around freely.

Adjustable components

Adjustable front seat shoulder anchor

Adjust the shoulder anchor position to your size.

1. To lower–
Push the lock release button in and slide the anchor down.
2. To raise–
Slide the anchor up.

After adjustment, make sure the anchor is locked in position.



CTY13AV013

! CAUTION

Always make sure the shoulder belt is positioned across the centre of your shoulder. The belt should be kept away from your neck, but not fall off your shoulder. Failure to do so could reduce the amount of protection in an accident and cause death or serious injuries in a collision.

Rear seatbelt guide

If it comes free, pass the seatbelt through the rear seatbelt guide before using.

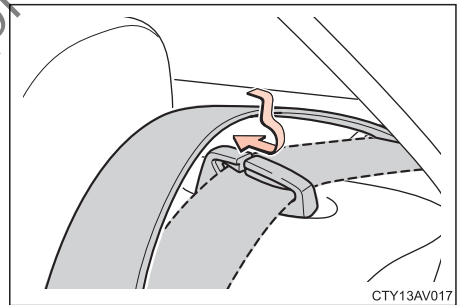

CTY13AV017

! CAUTION

- Always make sure the shoulder belt passes through the guide when using the seatbelt. Failure to correctly position the belt may reduce the amount of protection in an accident and could lead to serious injuries in a collision or sudden stop.
- Always make sure the seatbelt is not twisted, does not get caught in the guide or the seatback and is arranged in the correct position.

Automatic locking retractor (ALR)

The rear seatbelts have an additional locking feature used to hold a child restraint system securely. When this feature is activated, the seatbelt is locked from extending from the last retracted position. For details about this feature, refer to "Child restraint" on page 73.

To unlock the seatbelt, unbuckle the belt, allow it to fully retract then pull it out again.

Adjustable components

TILT AND TELESCOPIC STEERING WHEEL

To adjust the steering wheel position, hold the steering wheel and push down the lock release lever.

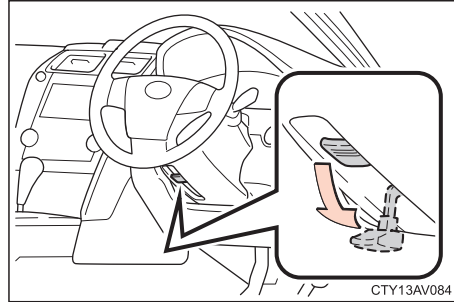

Adjust the steering wheel to the desired angle and push or pull it to the desired steering column length.

Return the lock release lever to its original position.

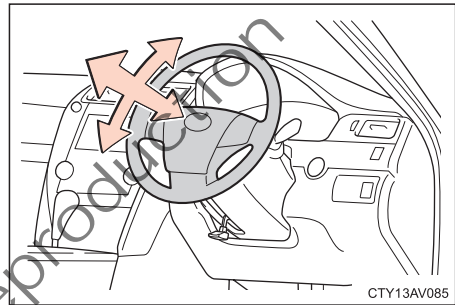

CAUTION

Do not adjust the steering wheel while the vehicle is moving. Doing so may cause the driver to lose control of the vehicle and an accident may occur resulting in death or serious injuries.

After adjusting the steering wheel, try moving it up and down or forward and rearward to make sure it is locked in position.

Adjustable components

ANTI-GLARE INSIDE REAR VIEW MIRROR

Adjust the mirror so that you can just see the rear of your vehicle in the mirror.

The height of the mirror can also be adjusted up or down.

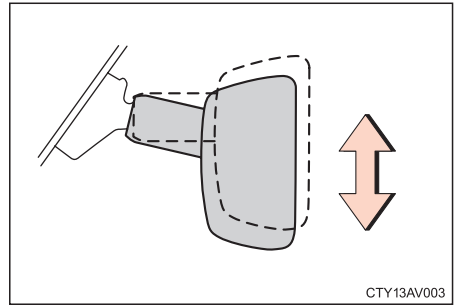

! CAUTION

Do not adjust the mirror while the vehicle is moving. Doing so may cause the driver to lose control of the vehicle and an accident may occur resulting in death or serious injury.

To reduce glare from the headlights of the vehicle behind you during night driving, operate the lever on the lower edge of the mirror.

1. Daylight driving–
The reflection in the mirror has greater clarity at this position.
2. Night driving–
Remember that by reducing glare you also lose some rear view clarity.

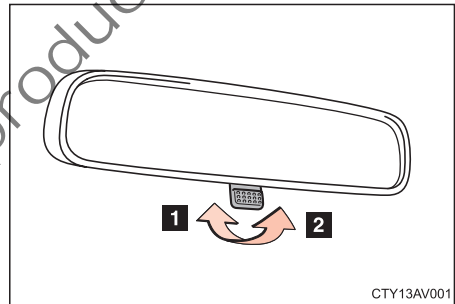

AUTO ANTI-GLARE INSIDE REAR VIEW MIRROR

Adjust the mirror so that you can just see the rear of your vehicle in the mirror.

The height of the mirror can also be adjusted up or down.

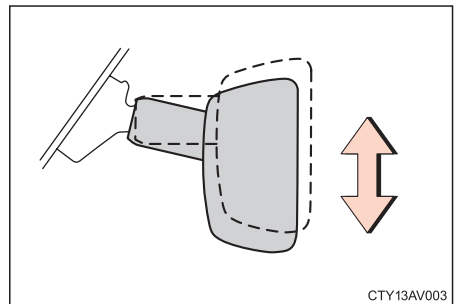

! CAUTION

Do not adjust the mirror while the vehicle is moving. Doing so may cause the driver to lose control of the vehicle and an accident may occur resulting in death or serious injury.

Adjustable components

This mirror is equipped with auto anti-glare function designed to automatically reduce glare from the headlamps of the vehicle behind you during night driving.

When the **POWER** switch is in **ON** mode, the inside rear view mirror always turns on in the automatic function mode.

The indicator illuminates to show you the function is on.

In automatic function mode, if the mirror detects light from the headlamps of the vehicle behind you, the mirror surface darkens slightly to reduce the reflected light.

To turn the automatic function off or on, push the switch.

When the inside air temperature is low, it may take a little longer for the mirror to darken in response to the detection of headlamps.

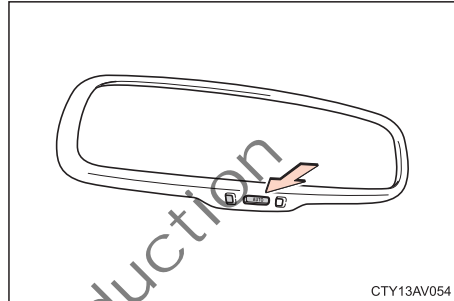

Sensors are located on both sides of the mirror. To ensure correct functioning of anti-glare mirror, do not touch or cover the sensors.

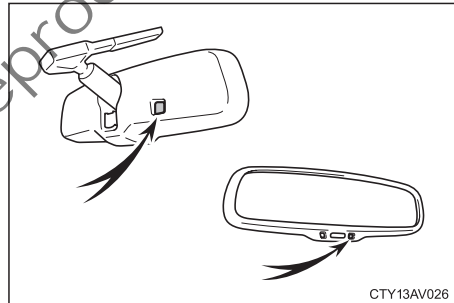

OUTSIDE REAR VIEW MIRRORS

Adjust the mirror so that you can just see the side of your vehicle in the mirror.

To select a mirror to adjust, press the switch.

1. Left-hand mirror.
2. Right-hand mirror.

Mirrors can be adjusted when the **POWER** switch is in **ACCESSORY** or **ON** mode.

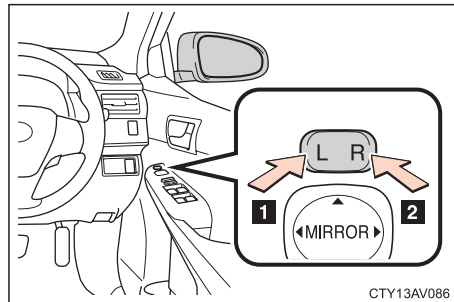

Adjustable components

To adjust the mirror, press the switch in the desired direction.

1. Up.
2. Right.
3. Down.
4. Left.

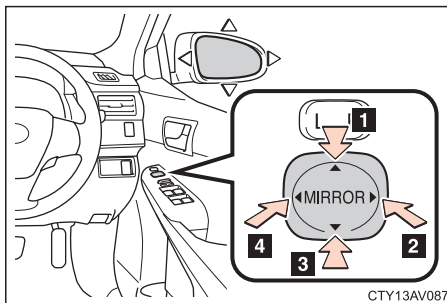

CTY13AV087

⚠ CAUTION

- Do not adjust the mirror while the vehicle is moving. Doing so may cause the driver to lose control of the vehicle causing an accident resulting in death or serious injury.
- If ice should jam the mirror, do not operate the control or scrape the mirror face. Use a spray de-icer to free the mirror.

Folding rear view mirrors

The rear view mirrors can be folded backward for parking in compact areas.

To fold the rear view mirror, push backward.

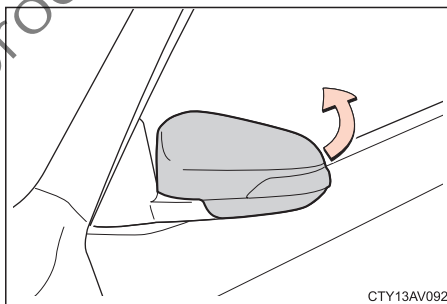

CTY13AV092

⚠ CAUTION

Do not drive with the mirrors folded backward. Both the driver and passenger side rear view mirrors must be extended and correctly adjusted before driving.

Linked mirror function when reversing (vehicles with driving position memory)

The outside rear view mirrors will automatically angle downwards when the vehicle is reversing in order to give a better view of the ground.

This function will not operate when the mirror select switch is in the neutral position (between L and R positions).

Automatic mirror angle adjustment (vehicles with driving position memory)

A desired mirror angle can be entered to memory and recalled automatically by the driving position memory. For details, refer to "Driving position memory system" on page 38.

Opening and closing the windows and moon roof

Opening and closing the windows and moon roof

POWER WINDOWS

The windows can be operated with the power window switch on each door. Press the POWER switch to ON mode.

Normal operation

The window moves as long as you hold the switch.

1. To close the window, lightly pull the switch up.
2. To open the window, lightly push the switch down.

One-touch operation for driver's door

3. To close the window, pull the switch up completely and then release it.
4. To open the window, push the switch down completely and then release it.

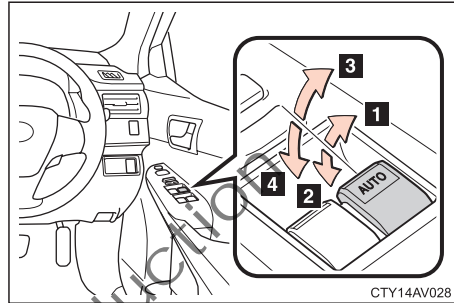

CTY14AV028

- Pushing the switch in the opposite direction will stop window travel partway.

Hybrid system off operation

If both front doors are closed, the power windows can be operated for about 45 seconds after the POWER switch is pressed to ACCESSORY or off. They stop working if either front door is opened.

Jam protection function for driver's door

During closing operation, the driver's window will stop and open about half way if something gets caught between the window and window frame.

If the window receives a strong impact, this function may work even if nothing is caught.

⚠ CAUTION

- The jam protection function does not work if the driver's window switch is completely pulled up and held.
- Never try jamming any part of your body to make the jam protection function work intentionally.
- The jam protection function may not work if something gets caught just before the window is fully closed.

Opening and closing the windows and moon roof

Window lock switch

If you press the window lock switch on the driver's door, the front and rear passenger's windows cannot be operated.

Use this switch to prevent children from accidentally opening or closing a window.

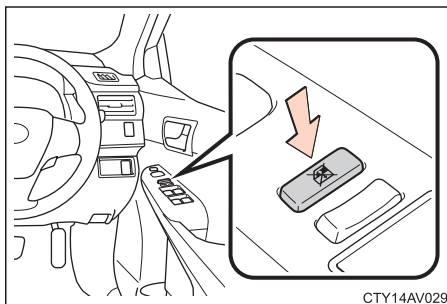

CTY14AV029

⚠ CAUTION

To avoid death or serious personal injury, you must do the following.

- Before you close the power windows, always make sure the heads, hands and other parts of the bodies of all occupants are kept completely inside the vehicle.
- When small children are in the vehicle, never let them use the power window switches without supervision. Use the window lock switch to prevent them from making unexpected use of the switches.
- Never leave anyone (particularly a small child) alone in your vehicle, especially with the key left in your vehicle. Otherwise, he / she could use the power window switch and become trapped in the window opening. Unattended children are at particular risk of injury.
- The jam protection function may not work if something gets caught just before the window is fully closed.

When the driver's power window does not close normally

If the jam protection function is operating abnormally and the window cannot be closed, perform the following operations using the driver's door power window switch.

- After stopping the vehicle, the window can be closed by holding the power window switch in the one-touch closing position while the POWER switch is pressed to ON mode.
- If the window still cannot be closed even by carrying out the previous step, initialise the function by performing the following procedure.
 1. Hold the power window switch in the one-touch closing position. Continue holding the switch for a further 6 seconds after the window has closed.
 2. Hold the power window switch in the one-touch opening position. Continue holding the switch for a further 2 seconds after the window has opened completely.
 3. Hold the power window switch in the one-touch closing position once again. Continue holding the switch for a further 2 seconds after the window has closed.

Opening and closing the windows and moon roof

- If you release the switch while the window is moving, start again from the beginning.
- If the window continues to close but then re-open slightly even after performing the above procedure correctly, have the vehicle inspected by your Toyota dealer.

Customisable features that can be modified

For further information refer to “Customisable features” on page 339.

MOON ROOF

To operate the moon roof, use the switches on the overhead console while the POWER switch is pressed to ON mode.

The sunshade can be opened or closed by hand.

Sliding operation

1. Push the OPEN switch to open the moon roof.
The moon roof will open and stop part-way from the fully opened position. Push the switch again to fully open the moon roof.
2. Push the CLOSE switch to close the moon roof.
The moon roof will fully close automatically.

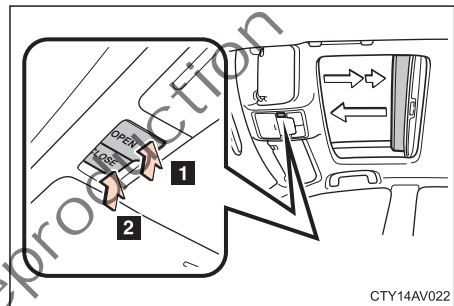

- To stop the moon roof in another position when opening or closing, push one of the moon roof switches briefly.
- As driving with the moon roof opened fully may cause wind throbs, we recommend you drive with the moon roof part-way from the fully opened position.
- If the sunshade was closed, it will be opened along with the moon roof.

Tilting operation

1. Press the UP switch to tilt the moon roof.
The roof will fully tilt up automatically.
 2. Press the DOWN switch to close the moon roof.
The roof will fully tilt down automatically.
- To stop the roof part-way, press one of the moon roof switches briefly.

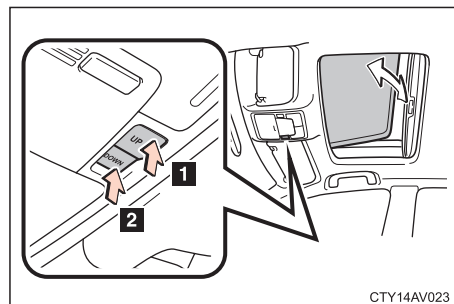

Hybrid system off operation

The moon roof can be operated for about 45 seconds after the POWER switch is pressed off. It stops working when either front door is opened.

Opening and closing the windows and moon roof

Moon roof open reminder function

An alarm will sound when the driver's door is opened with the moon roof not fully closed and the POWER switch is OFF.

Jam protection function

If an object is caught between the moon roof and frame during closing operation, the moon roof stops and reopens slightly.

CAUTION

To avoid death or serious personal injury, you must do the following.

- If any part of someone's body is caught in the closing roof, it could result in death or serious injury.
- While the vehicle is moving, always keep the heads, hands and other parts of the bodies of all occupants away from the roof opening. Otherwise, they could be killed or seriously injured if the vehicle stops suddenly or if the vehicle is involved in an accident.
- Before you close the moon roof, always make sure nobody places his or her head, hands and/or other parts of the body in the roof opening.
- Never leave anyone (particularly a small child) alone in your vehicle, especially with the key left in the vehicle. Otherwise, he / she could use the moon roof switch and get trapped in the roof opening.
- Never sit on top of the vehicle around the roof opening.
- Never try jamming any part of your body to activate the jam protection function intentionally, as it could result in a death or serious injury.
- The jam protection function may not work if something gets caught just before the moon roof is fully closed.

When the moon roof does not close normally

If the moon roof closes but then re-opens slightly–

1. Stop the vehicle.
2. Press and hold the CLOSE switch (*1).

The moon roof will close, reopen and pause for approximately 10 seconds (*2). Then it will close again, tilt up and pause for approximately 1 second. Finally, it will tilt down, open and close.

3. Check to make sure the moon roof is completely closed and then release the switch.

If the moon roof tilts down but then tilts back up–

1. Stop the vehicle.
2. Press and hold the UP switch (*1) until the moon roof moves into the tilt up position and stops.

Opening and closing the windows and moon roof

3. Release the UP switch once and then press and hold the UP switch again (*1).
The moon roof will pause for approximately 10 seconds in the tilt up position (*2).
Then it will adjust slightly and pause for approximately 1 second. Finally, it will tilt down, open and close.
 4. Check to make sure the moon roof is completely closed and then release the switch.
- *1: If the switch is released at the incorrect time, the procedure will have to be performed again from the beginning.
- *2: If the switch is released after the above mentioned 10 second pause, automatic operation will be disabled. In that case, press and hold the CLOSE switch or press and hold the UP switch.
The moon roof will tilt up and pause for approximately 1 second. Then it will tilt down, open and close. Check to make sure the moon roof is completely closed and then release the switch.

If the moon roof does not fully close even after performing the above procedure correctly, have the vehicle inspected by your Toyota dealer.

Customisable features that can be modified

For further information refer to "Customisable features" on page 339.

Not for Reproduction

Refuelling

CAUTION

When refuelling the vehicle

Observe the following precautions while refuelling the vehicle. Failure to do so may result in death or serious injury.

- After exiting the vehicle and before opening the fuel door, touch an unpainted metal surface to discharge any static electricity.
It is important to discharge static electricity before refuelling because sparks resulting from static electricity can cause fuel vapours to ignite while refuelling.
- Always hold the grip on the fuel tank cap and turn it slowly to remove it.
A whooshing sound may be heard when the fuel tank cap is loosened. Wait until the sound cannot be heard before fully removing the cap. In hot weather, pressurised fuel may spray out the filler neck and cause injury.
- Do not allow anyone that has not discharged static electricity from their body to come close to an open fuel tank.
- Do not inhale fuel vapours. Fuel contains substances that are harmful if inhaled.
- Do not smoke while refuelling the vehicle. Doing so may cause the fuel to ignite and cause a fire.
- Do not return to the vehicle or touch any person or object that is statically charged. This may cause static electricity to build up, resulting in a possible ignition hazard.
- Securely insert the fuel nozzle into the fuel filler neck. If fuel is added with the nozzle slightly lifted away from the fuel filler neck, the automatic shut off function may not operate, resulting in fuel overflowing from the tank.
- Avoid spilling fuel during refilling; doing so may damage the vehicle. Immediately pour water on any spilled fuel.

Use of ethanol blended fuel

Toyota allows the use of ethanol blended fuel where the ethanol content is up to 10%. For details, refer to "Fuel" on page 334.

FUEL TANK CAP

When refuelling, turn off the hybrid system and close the doors and windows.

To open the fuel filler door, pull the lever up.

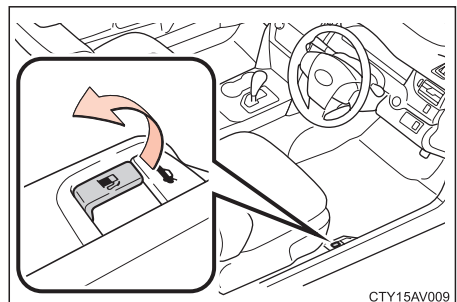

CTY15AV009

Refuelling

To remove the fuel tank cap, turn the cap slowly counterclockwise, then pause slightly before removing it. It is not unusual to hear a slight wooshing sound when the cap is opened.

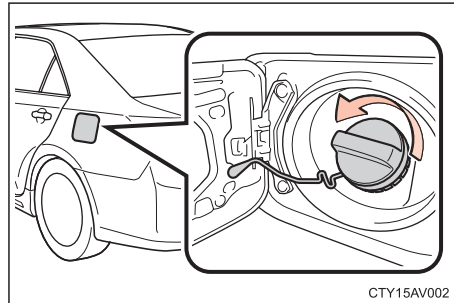

The removed cap can be stored on the back side of the fuel filler door.

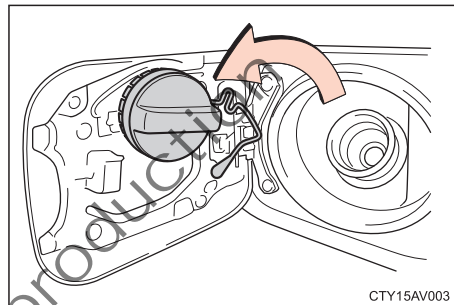

When installing the cap, turn the cap clockwise until you hear a click; this indicates the cap is fully closed.

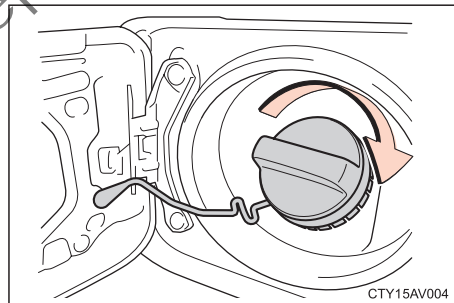

⚠ CAUTION

When replacing the fuel cap

- Make sure the cap is installed securely to prevent fuel spillage when driving.
- Only use a genuine Toyota fuel tank cap designed for your vehicle. Doing otherwise may cause a fire or other incident which may result in death or serious injury.

⚠ NOTICE

To prevent damage to the cap, apply force only in the turning direction to the cap. Do not pull or prise it.

Theft deterrent system

ENGINE IMMOBILISER SYSTEM

The engine immobiliser system is a theft prevention system that uses an electronic code. An electronic chip in each key contains an electronic code that is transmitted to the vehicle. Only when the electronic code in the chip corresponds to the vehicle's registered code will the immobiliser system be cancelled allowing the hybrid system to start.

The engine immobiliser system is automatically set when The POWER switch is pressed off

The indicator will start flashing to show the system is set.

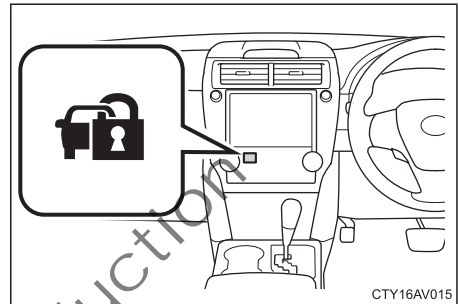

NOTICE

Contact your Toyota dealer if any of the following indicator conditions occurs:

- The indicator stays on except when the alarm is setting or activating. Refer to "Setting the alarm system" on page 58.
- The indicator does not start flashing when the POWER switch is pressed OFF.
- The indicator light flashes erratically.

The engine immobiliser system is automatically cancelled when you enter the vehicle carrying an electronic key and press the POWER switch.

If the electronic key battery is discharged, the hybrid system can still be started. Refer to "If the electronic key does not operate properly" on page 321.

When the system is cancelled, the indicator will go off.

For your Toyota dealer to make you a new key with a built-in transponder chip, your dealer will need your key number and electronic key. However, there is a limit to the number of additional keys your Toyota dealer can make for you.

If you make your own duplicate key, you will not be able to cancel the engine immobiliser system or start the hybrid system.

NOTICE

Do not modify, remove or disassemble the engine immobiliser system.

If any unauthorised changes or modifications are made, correct operation of the system cannot be guaranteed.

Theft deterrent system

ALARM

To deter vehicle theft, the alarm is designed to sound if any of the doors, boot or bonnet is forcibly unlocked or opened, or a battery terminal is disconnected and then reconnected when the vehicle is locked.

The alarm will also sound if the PANIC switch on the key is pressed. Refer to "Panic mode" on page 17.

When the alarm is triggered, the horn sounds and the turn signal lights flash.



Setting the alarm system

1. Press the POWER switch OFF.
2. The engine immobiliser system is set and the indicator will start flashing.
3. Ensure all passengers have exited the vehicle.
4. Close and lock all the doors, boot and bonnet. Also check the windows and moon roof are closed.
5. The indicator light will remain on when all the doors, boot and bonnet are closed and locked.
6. After 30 seconds, the alarm system will automatically set and the indicator will start flashing again.
7. After making sure the indicator light starts flashing, you may leave the vehicle.

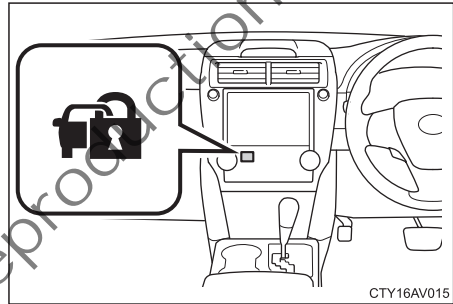

Triggering the alarm system

The alarm will sound under the following conditions.

- A locked door is unlocked or the boot lid is opened in any way other than using the wireless remote control, smart entry function or with a key.
- The bonnet is forcibly opened.
- A person is inside the vehicle and opens a door, the boot lid or bonnet while the alarm is set.



Theft deterrent system

- If the 12-volt auxiliary battery terminal is disconnected and reconnected while the vehicle is locked.

The indicator will illuminate and all the doors will be automatically locked while the alarm is sounding.

After 30 seconds, the alarm will automatically stop and the indicator light will start flashing again.

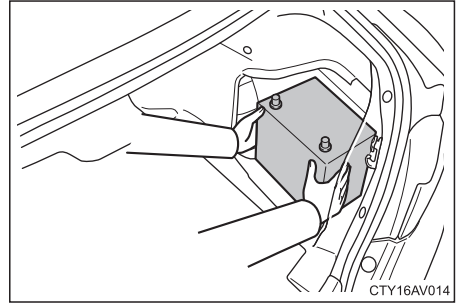

Reactivating the alarm

The system will automatically reset after the alarm stops sounding and will activate again under the same circumstances described in "Triggering the alarm system".

Stopping the alarm

The alarm can be stopped by performing any of the following:

- Press the POWER switch to ON mode or start the hybrid system.
- Unlock any of the doors with the wireless remote control, smart entry function or key.
- Open the boot with the wireless remote control or the smart entry function.

Deactivating the system

The system will be deactivated by the above mentioned ways.

Not for Reproduction

Safety information

Safety information

SRS COMPONENTS

The main SRS (Supplemental Restraint System) components are shown below. The SRS system is controlled by the airbag sensor assembly which together with front and side impact sensors detect a collision and may deploy the seatbelt pretensioners and airbags as determined by the force and direction of impact.

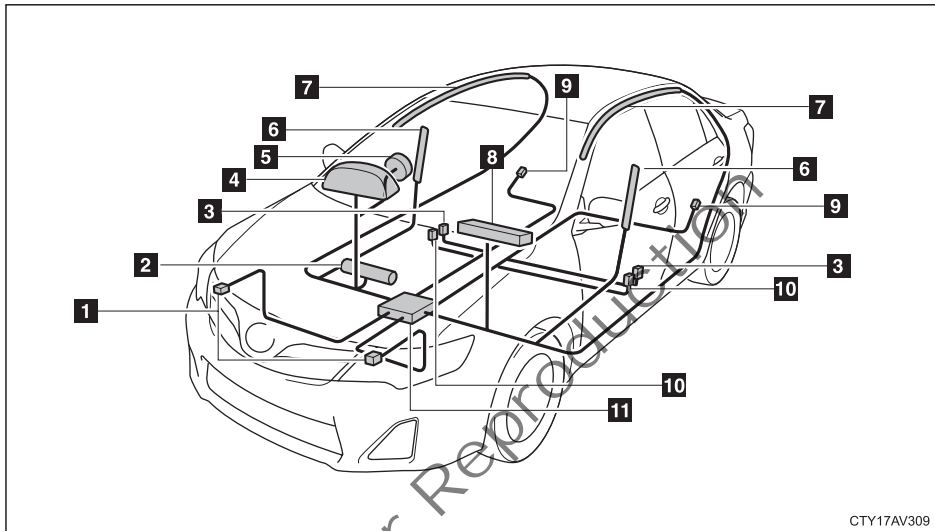

CTY17AV309

1	Front impact sensors	7	Curtain shield airbags
2	Knee airbag	8	Front passenger airbag
3	Side impact sensors (front)	9	Side impact sensors (rear)
4	SRS warning light	10	Seatbelt pretensioners and force limiters
5	Driver airbag	11	Airbag sensor assembly
6	Front side airbags		

SEATBELT PRETENSIONERS

The driver and front passenger seatbelt pretensioners are designed to be activated in response to certain types of severe frontal collision.

When the impact sensor detects a severe frontal impact, the front seatbelts are quickly drawn back by the retractors so the belts snugly restrain the occupants.

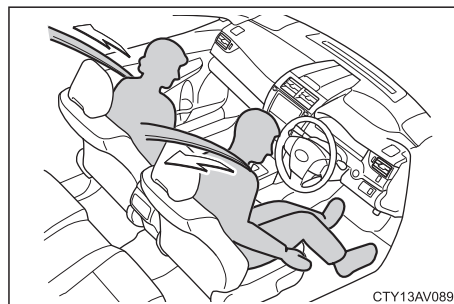

CTY13AV089

INFORMATION

The seatbelt pretensioners do not activate in a minor frontal impact, a side impact or in a rear impact or rollover. Depending on the type of collision it is possible that only the pretensioners are activated and not the SRS airbags.

While the seatbelt pretensioners are being activated, an operating noise may be heard and a small amount of non-toxic gas may be released. This does not indicate that a fire is occurring. This gas is normally harmless.

CAUTION

- If the seatbelt pretensioners have been activated, the SRS warning light will illuminate and the seatbelt cannot be used again and the seatbelt assemblies must be replaced.
- Do not modify, remove, strike or open the seatbelt pretensioner assemblies, airbag sensor or surrounding area or wiring. Failure to follow these instructions may prevent the seatbelt pretensioners from activating correctly, cause sudden operation of the system or disable the system, which could result in death or serious injury. Consult your Toyota dealer about any repair and modification.

NOTICE

Do not perform any of the following changes without consulting your Toyota dealer. Such changes can interfere with correct operation of the seatbelt pretensioners in some cases.

- Installation of electronic devices such as a mobile two-way radio, cassette tape player or compact disc player.
- Repairs on or near the front seatbelt retractor assemblies.
- Modification of the suspension system.
- Modification of the front end structure.
- Attachment of a grille guard (bull bar, kangaroo bar, etc.), snowplough, winches or any other equipment to the front end.
- Repairs made on or near the front bumper bar, front end structure or console.

Safety information

SRS AIRBAGS

The SRS airbags are designed to provide further protection for the driver, front passenger and rear outside passenger's in addition to the primary safety protection provided by the seatbelts.

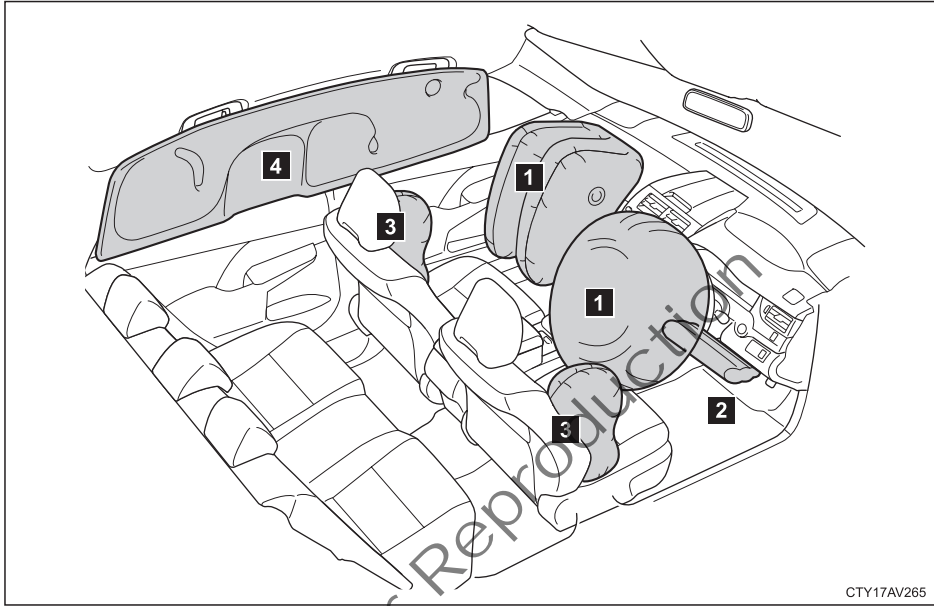

CTY17AV265

1. SRS driver airbag / front passenger airbag–
Can help protect the head and chest of the driver and front passenger from impact with interior components
2. SRS knee airbag–
Can help provide driver protection
3. SRS side airbags–
Can help protect the torso of the front seat occupants
4. SRS curtain shield airbags–
Can help protect primarily the head of occupants in the outer seats

SRS front airbags

In response to a severe frontal impact, the SRS front airbags (driver, front passenger and knee) work with the seatbelts and seatbelt pretensioners to help reduce injury by inflating. The front passenger airbag is activated even with no passenger in the front seat.

The front impact sensors constantly monitor the forward deceleration of the vehicle. If an impact results in a forward deceleration beyond the designed threshold level, the system triggers the airbag inflators.

At this time a chemical reaction in the inflators very quickly fills the airbags with non-toxic gas to help restrain the forward motion of the occupants.

The front airbags then quickly deflate, so there is no obstruction of the driver's vision should it be necessary to continue driving.

SRS side and curtain shield airbags

In response to a severe side impact, the SRS side airbags and curtain shield airbags work with the seatbelts.

The SRS side airbag and curtain shield airbag on the passenger side are activated even with no passenger in the front seat or rear outside seat. The curtain shield airbags may activate even when the side airbags are not activated.

In a severe side impact, the side impact sensors trigger the side airbag inflators and/or the curtain shield airbag inflators on that side of the vehicle.

At this time a chemical reaction in the inflators quickly fills the airbags with non-toxic gas to help restrain the lateral motion of the occupants.

When the airbags inflate, they produce a loud noise and release some smoke and residue along with non-toxic gas. This does not indicate a fire.

! CAUTION

- Always wear your seatbelt correctly.
- The SRS front airbag system is designed only to supplement the primary protection of the driver and front passenger seatbelt systems.
- The SRS side airbag and curtain shield airbag system is designed to supplement the seatbelt systems of the driver, front passenger and rear outside passenger.
- The driver and front passenger can be killed or seriously injured by the inflating airbags or thrown out of the vehicle if they do not wear seatbelts correctly. For instructions and precautions concerning the seatbelt system refer to "Seatbelts" on page 41 and to "Front seats" on page 33.
- During sudden braking, immediately before a collision, an unrestrained driver or front passenger can move forward into direct contact with, or close proximity to, the airbag which may then deploy during the collision. This can result in death or serious injury.
- No-one should lean against areas from which SRS airbags deploy: the doors, the steering wheel, the rear of the driver's and front passenger seats, rear pillar or roof side rail, as sudden inflation of the airbags could cause death or serious injury. For locations of the airbags refer to "SRS components" on page 60.
- Toyota strongly recommends that all infants and children be placed in the rear seat of the vehicle and correctly restrained.
- Incorrectly seated and/or incorrectly restrained infants and children can be killed or seriously injured by the deploying airbags.
- An infant or child who is too small to use a seatbelt must be correctly secured using a child restraint system. For instructions concerning the installation of a child restraint system, refer to "Child restraint" on page 73.

Safety information

⚠ NOTICE

- The smoke, residue and non-toxic gas released when airbags inflate may remain inside the vehicle for some time, causing some irritation to the eyes, skin or breathing.
- Wash off any residue with soap and water as soon as possible to prevent any potential skin irritation.
- If you can safely exit from the vehicle, you should do so immediately.

SRS front airbag deployment conditions

The SRS front airbags are designed to deploy in severe (usually frontal) collisions where the magnitude and duration of the forward deceleration of the vehicle exceeds the designed threshold level.

The SRS front airbags will deploy if the severity of the impact is above the designed threshold level, comparable to an approximate 25 km/h collision when the vehicle has the impact straight into a fixed barrier that does not move or deform.

However, this threshold velocity will be considerably higher if the vehicle strikes an object, such as a parked vehicle or sign post, which can move or deform on impact, or if the vehicle is involved in an under-ride collision (e.g. a collision in which the front of the vehicle under-rides, or goes under, the bed of a truck, etc.).

⚠ NOTICE

- It is possible that in some collisions where the forward deceleration of the vehicle is very close to the designed threshold level, the SRS front airbags and the seatbelt pretensioners may not activate together.
- Always wear your seatbelts properly.

⚠ NOTICE

The SRS front airbags are not generally designed to inflate if the vehicle is involved in a side or rear collision, if it rolls over, or if it is involved in a low-speed frontal collision. But, whenever a collision of any type causes sufficient forward deceleration of the vehicle, deployment of the SRS front airbags may occur.

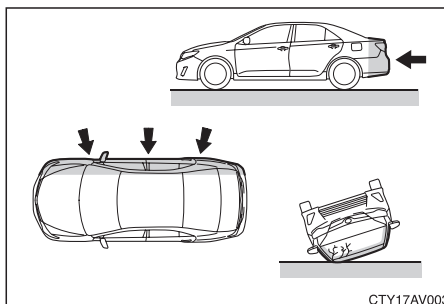

Safety information

The SRS front airbags may also deploy if a serious impact occurs to the underside of your vehicle. Some examples are shown in the illustration.

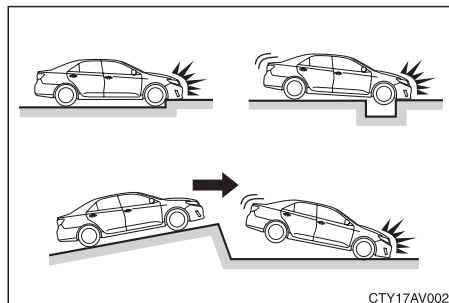

SRS side and curtain shield airbag deployment conditions

The SRS side airbags and curtain shield airbags are designed to inflate when the passenger compartment area suffers a severe impact from the side.

NOTICE

The SRS side airbags and curtain shield airbags are not generally designed to inflate if the vehicle is involved in a front or rear collision, if it rolls over, or if it is involved in a low-speed side collision.

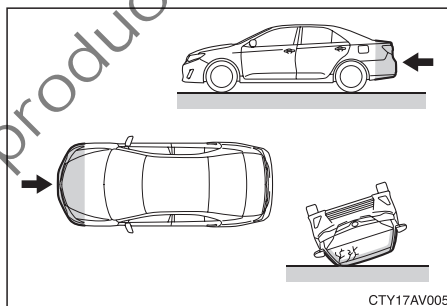

The SRS side airbag and curtain shield airbag system may also not activate if the vehicle is subjected to a collision from the side at certain angles, or a collision to the side of the vehicle body other than the passenger compartment as shown in the illustration.

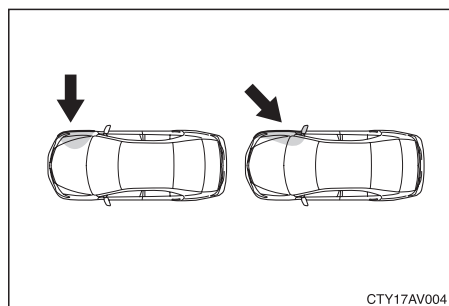

When to contact your Toyota dealer

In the following cases, contact your Toyota dealer as soon as possible.

- The SRS front airbags have been inflated.

Safety information

- The front of the vehicle (shaded in the illustration) is damaged or was involved in an accident that was not severe enough to cause the SRS front airbags to inflate.

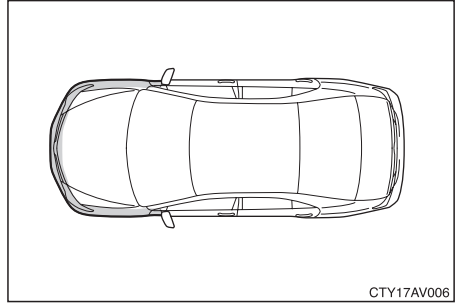

- The pad section of the steering wheel or instrument panel near the front passenger airbag and knee airbag (shaded in the illustration) is scratched, cracked, or otherwise damaged.

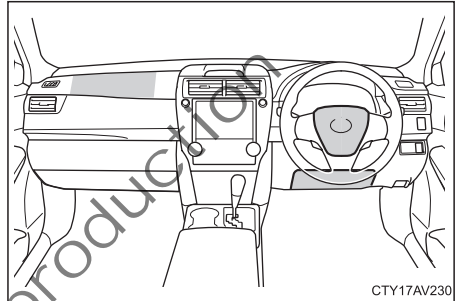

- Any of the SRS side airbags and curtain shield airbags have been inflated.
- The portion of the doors (shaded in the illustration) is damaged or was involved in an accident that was not severe enough to cause the SRS side airbags and curtain shield airbags to inflate.

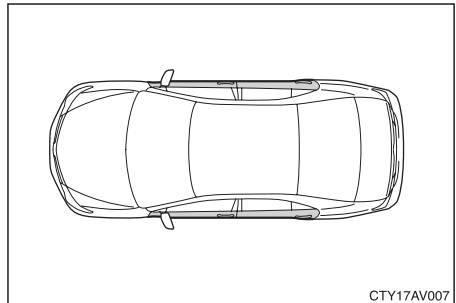

- The surface of the seats with the side airbag (shaded in the illustration) is scratched, cracked, or otherwise damaged.
- Any portion of the front pillars, rear pillars or roof side rail garnishes (padding) containing the curtain shield airbags inside (shaded in the illustration) is scratched, cracked, or otherwise damaged.

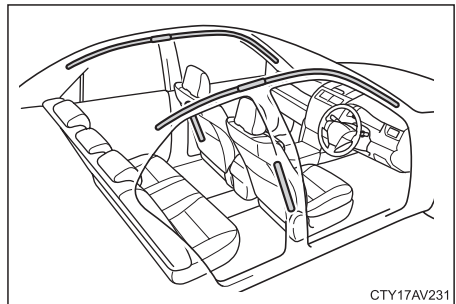

SRS warning light

This warning light illuminates when the POWER switch is pressed to ON mode.

The warning light goes off after about 6 seconds. This means the SRS is operating correctly.

The SRS warning light monitors the entire SRS including all of the airbag and impact sensors, airbags, seatbelt pretensioners, interconnecting wiring and power sources.

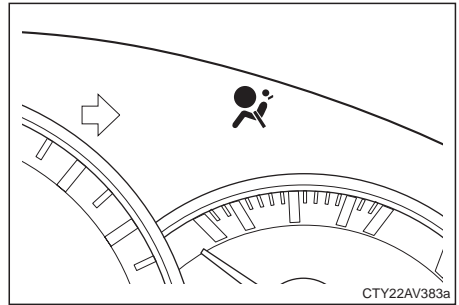

For further information, refer to “Indicators and warning lights” on page 95

⚠ CAUTION

If any of the following conditions occur, this indicates a malfunction of the airbags or seatbelt pretensioners. Contact your Toyota dealer as soon as possible.

- The SRS warning light does not illuminate when the POWER switch is pressed to ON mode or remains on for more than 6 seconds.
- The SRS warning light illuminates or starts flashing while driving.

SRS AIRBAG PRECAUTIONS

Deployment of the airbags happens in a fraction of a second, so the airbags must inflate with considerable force. The airbags inflate only once.

While the system is designed to reduce serious injuries, primarily to the head and chest, it may also cause other, less severe injuries which can be avoided by following the instructions in the following Caution boxes.

Safety information

CAUTION

General SRS precautions

- Deployment of the airbags may cause injuries to the body, particularly to the face, chest, arms and hands, usually in the nature of minor burns or abrasions and/or swelling.
- The force of a deploying airbag can cause more serious injuries, especially if an occupant's hands, arms, chest, head or any other body part is in close proximity to the airbag module at the time of deployment.
- Parts of the airbag module (steering wheel hub, airbag cover and inflator) may be hot for several minutes after deployment of the airbag, so do not touch!
- The windscreen may be damaged by absorbing some of the force of the inflating airbag.
- To minimise the risk of serious injury it is important for the occupant to:
 - Avoid placing any object or part of the body between the occupant and the airbag module
 - Sit straight and well back into the seat
 - Wear the available seatbelt correctly
 - Sit as far as possible from the airbag module while still maintaining control of the vehicle
- The driver or front passenger who is too close to the steering wheel or instrument panel during airbag deployment can be killed or seriously injured. Toyota strongly recommends that:
 - The driver sit as far back as possible from the steering wheel while still maintaining control of the vehicle
 - The front passenger sit as far back as possible from the instrument panel
 - All vehicle occupants must be correctly restrained using the available seatbelts

For instructions and precautions concerning the seating position, refer to "Front seats" on page 33.
- To avoid death or serious injury you need to comply with the following instructions. Failure to follow these instructions may prevent the SRS from activating correctly, causing sudden activation of the system or disabling the system:
 - Do not modify or remove any wiring
 - Do not modify, remove, strike or open any components such as the steering wheel pad, steering wheel column cover, front passenger airbag cover, front passenger airbag or airbag sensor assembly
 - Consult your Toyota dealer about any repair and modification

! CAUTION

Front SRS precautions

- **Extreme Hazard! Do not use a rearward facing child restraint on a seat protected by an airbag in front of it! The force of the rapid inflation of the front passenger airbag can cause death or serious injury to the child.**

A warning label on the passenger side instrument panel as shown, and on the driver's side sun visor reminds you not to put a rearward facing child restraint system on the front passenger seat at anytime.

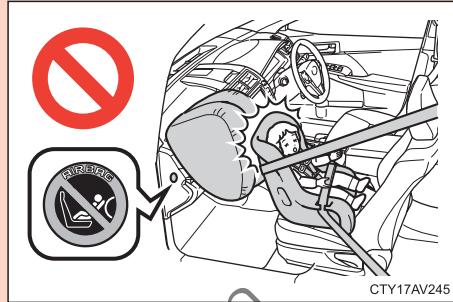

- Do not sit on the edge of the seat or lean against the instrument panel when the vehicle is in use, since the front passenger airbag could inflate with considerable speed and force.

Anyone who is up against, or very close to, an airbag when it inflates, can be killed or seriously injured. Sit up straight and well back in the seat, and always use your seatbelt correctly.

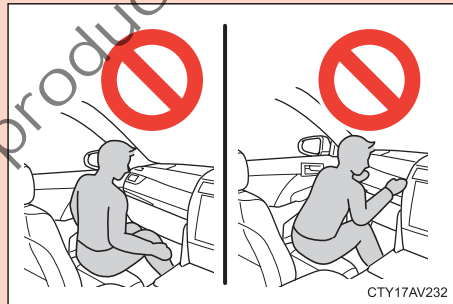

- Toyota strongly recommends that all infants and children be placed in the rear seat of the vehicle and be correctly restrained.
- Do not allow a child to stand up or kneel on the front passenger seat, since the front passenger airbag could inflate with considerable speed and force. Otherwise, the child may be killed or seriously injured.

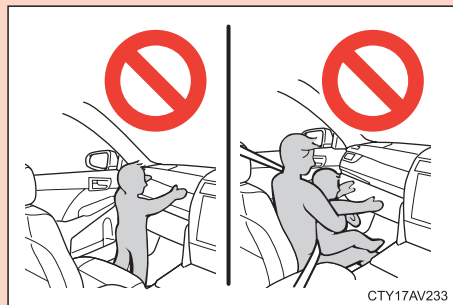

- Do not hold a child on your lap or in your arms. Use a child restraint system in the rear seat. For instructions concerning the installation of a child restraint system, refer to "Child restraint" on page 73.

Safety information

! CAUTION

- Do not put anything or any part of your body on or in front of the instrument panel or steering wheel pad that houses the front airbag system because they might restrict inflation or cause death or serious injury as they are projected rearward by the force of the deploying airbags.
- The driver and front passenger should not hold objects in their arms or on their knees.

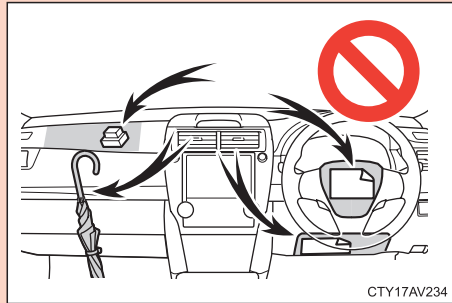

! CAUTION

Side and curtain shield SRS precautions

SRS side airbags and curtain shield airbags inflate with considerable force. To reduce the possibility of death or serious injury when they inflate, the driver, front passenger and rear outside passengers must:

- Wear their seatbelts correctly
- Remain correctly seated with their backs upright and against the seats at all times.

The following pages contain more specific directions regarding precautions that should be taken in relation to the inflation of SRS airbags. Toyota recommends you consider these pages carefully.

! CAUTION

- Do not lean against the door when the vehicle is in use or place your head close to the area where the side or curtain shield airbag could inflate. These airbags could inflate with considerable speed and force which could result in death or serious injury.
- To minimise the risk of death or serious injury occurring during the inflation of airbags, sit up straight and well back in the seat. Ensure your weight is distributed evenly in the seat. Do not apply excessive weight to the outer side of the seats with a side airbag, and to the front pillar, rear pillar and roof side rail with a curtain shield airbag.
- Do not kneel on the passenger seat facing the passenger's side door. The side airbag and curtain shield airbag could inflate with considerable speed and force which may result in death or serious injury.
- Do not place head or hands out of windows. Otherwise, death or serious injury may result when the curtain shield airbags inflate
- Do not attach any object on or around the door or the area where the curtain shield airbag activates, such as on the windscreen and, side door glass, front and rear pillars, roof side rail and assist grips. Otherwise, the object will be thrown with great force when the side airbag inflates or, alternatively, the side airbag may not activate correctly. This may result in death or serious injury.

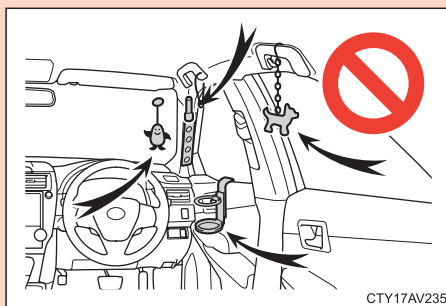

Safety information

CAUTION

- The driver and front passenger should not hold objects in their arms or on their knees in order to avoid death or serious injury when an airbag inflates.
- Do not hook a hanger, heavy or sharp pointed objects on the coat hook. If the curtain shield airbag inflates, those items will be projected with great force or the curtain shield airbag may not activate correctly, resulting in death or serious injury. When you hang clothes, hang them on the coat hook directly.
- Do not use seat accessories which cover the parts where the side airbags inflate. Such accessories may prevent the side airbags from activating correctly, causing death or serious injury.
- Do not modify or replace the seats or upholstery of the seats with side airbags. Such changes may prevent the side airbag system from activating correctly, disable the system or cause the side airbags to inflate accidentally, resulting in death or serious injury.
- Do not disassemble or repair the front and rear pillars and roof side rail containing the curtain shield airbags. Such changes may disable the system or cause the curtain shield airbags to inflate accidentally, resulting in death or serious injury.

Failure to follow these instructions can result in death or serious injury. Consult your Toyota dealer about any repair and modification.

NOTICE

Do not perform any of the following changes without consulting your Toyota dealer. Such changes can interfere with correct operation of the SRS front airbag system in some cases.

- Installation of electronic devices such as a mobile two-way radio, cassette tape player or compact disc player.
- Modification of the suspension system.
- Modification of the front end structure.
- Modification of the side structure of the passenger compartment.
- Attachment of a grille guard (bull bar, kangaroo bar, etc.), snowplough, winches or any other equipment to the front end.
- Repairs made on or near the front bumper bar, front end structure, console, steering column, steering wheel, front seat or instrument panel near the front passenger airbag.

CHILD RESTRAINT

Child restraint requirements

NOTICE

The Australian Road Rules mandate the following age-based requirements for child restraint and booster seats.

- **Children under 6 months** must use an approved, properly fastened and adjusted rearward facing restraint.
- **Children aged between 6 months and under 4 years** must use an approved, properly fastened and adjusted rearward facing child restraint OR a forward facing restraint.
- **Children aged between 4 years and under 7 years** must use an approved, properly fastened and adjusted forward facing restraint or an approved booster seat which is properly positioned and fastened.
- **If a car has two or more rows of seats, children under 4 years** must not travel in the front seat.
- **If all seats, other than the front seats, are being used by children under 7 years**, children aged between four and six years (inclusive) may travel in the front seat, provided they use an approved restraint or booster seat that is properly fitted.

Child restraint precautions

Toyota strongly recommends the use of child restraints that meet Australian Standard AS1754-2010 or later.

If a child is too large for a child restraint system, the child should sit in the rear seat and must be restrained using the vehicle's seatbelt. Refer to "Seatbelts" on page 41.

CAUTION

- For effective protection in automobile accidents and sudden stops, a child must be correctly restrained, using a seatbelt or child restraint system depending on the age and size of the child. Holding a child in your arms is not a substitute for a child restraint system. In an accident, the child can be crushed against the windscreen, or between you and the vehicle's interior.
- Toyota strongly recommends the use of a correct child restraint system which conforms to the size of the child, installed on the rear seat. According to accident statistics, the child is safer when correctly restrained in the rear seat than in the front seat.
- Never install a rear-facing child restraint system on the front passenger seat. In the event of an accident, the force of the rapid inflation of the front passenger airbag can cause death or serious injury to the child if the rear-facing child restraint system is installed on the front passenger seat.
- Australian law requires the use of an upper anchor strap on child restraint systems.

Safety information

CAUTION

- On vehicles with side airbags and curtain shield airbags, do not allow the child to lean his / her head or any part of his / her body against the door or the area of the seat, front or rear pillar or roof side rail from which the side airbags or curtain shield airbags deploy even if the child is seated in the child restraint system. It is dangerous if the side airbag and / or curtain shield airbag inflate, and the impact could cause death or serious injury to the child.
- Make sure you have complied with all installation instructions provided by the child restraint manufacturer and the system is correctly secured. If it is not secured correctly, it may cause death or serious injury to the child in the event of a sudden stop or accident.

When children are in the vehicle

- Do not allow children to play with the seatbelt. If the seatbelt becomes twisted around a child's neck, it may lead to choking or other serious injuries that could result in death. If this occurs and the buckle cannot be unfastened, scissors should be used to cut the belt.

When the child restraint system is not in use

- Keep the child restraint system properly secured on the seat even if it is not in use. Do not store the child restraint system unsecured in the passenger compartment.
- If it is necessary to detach the child restraint system, remove it from the vehicle or store it securely in the boot. This will prevent it from injuring passengers in the event of a sudden stop, sudden swerve or accident.

CHILD RESTRAINT SYSTEM

A child restraint system for a small child or baby must itself be correctly restrained on the seat with the lap portion of the lap/shoulder belt. You must carefully consult the manufacturer's instructions which accompany the child restraint system.

To provide correct restraint, use a child restraint system following the manufacturer's instructions about the appropriate age and size of the child for the child restraint system.

Install the child restraint system correctly following the instructions provided by its manufacturer. General directions are also provided under the following illustrations.

The child restraint system should be installed on the rear seat. According to accident statistics, the child is safer when correctly restrained in the rear seat than in the front seat.

When not using the child restraint system, keep it secured with the seatbelt or place it in the boot or somewhere other than the passenger compartment. This will prevent it from injuring passengers in the event of a sudden stop or accident.

Types of seatbelts

Your Toyota is fitted with two types of seatbelts:

- ELR (Emergency locking retractor)–
This belt locks when the belt is pulled out quickly and is fitted to the front seats.

- ELR / ALR (Emergency locking retractor / Automatic locking retractor)–
This belt also locks when the belt is pulled out quickly. In addition, it has a fully extended lock mode. When the belt is completely extended and is then retracted even slightly, the retractor locks the belt in that position and the belt cannot be extended.

The rear seatbelts in your Toyota are ELR / ALR type seatbelts. When installing a child restraint, fully extend the belt to place it in the lock mode.

Fasten the belt around the child restraint according to the manufacturer's directions and then allow the seatbelt to retract until the restraint is securely in place. The belt will be locked in position and cannot be extended.

To unlock the seatbelt, unbuckle it and allow it to fully retract.

Child restraint anchor fittings

For easy installation of child restraints, your vehicle has three child restraint anchor fittings.

When installing a child restraint, follow both the instructions here and those provided by the manufacturer of your child restraint.

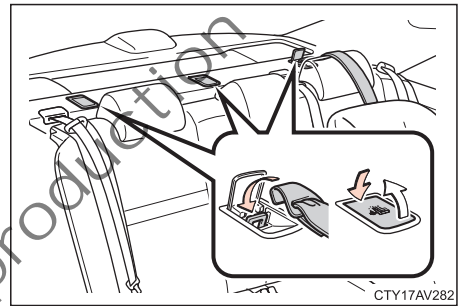

⚠ CAUTION

Warning

Child restraint anchorages are designed to withstand only those loads imposed by correctly fitted child restraints. Under no circumstances are they to be used for adult seatbelts, harnesses or for attaching other items or equipment to the vehicle.

To use the child restraint anchor fitting

Fix the child restraint system with the seatbelt according to the manufacturer's directions and in "Types of seatbelts" as previously described.

1. Open the lid of the anchor fitting.
2. Attach the child restraint anchor attaching clip to the child restraint anchor fitting.

Make sure the clip is securely attached.

3. Tighten the upper anchorage strap.

Close the cover when the child restraint anchor fitting is not in use.

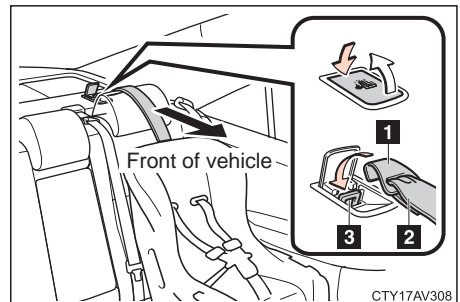

Safety information

! CAUTION

Make sure the upper anchor strap is securely attached, and check the child restraint system is secure by pushing and pulling it in different directions.

Follow all the installation instructions provided by its manufacturer.

FLOOR MAT

! CAUTION

Before driving the vehicle

- Check the floor mat is securely fixed in the correct place with all the provided retaining hooks (clips). Be especially careful to perform this check after cleaning the floor.
- With the hybrid system stopped and the shift lever in P position, fully depress each pedal to the floor to make sure it does not interfere with the floor mat.

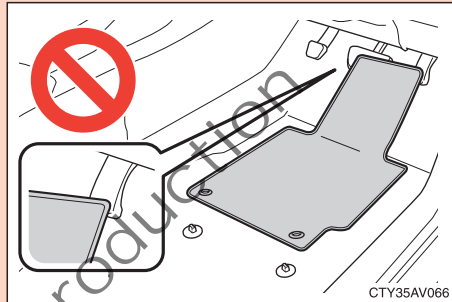

For details on correct floor mat installation refer to "Floor mat" on page 250

WHEN DRIVING

Driving procedures	78
POWER (IGNITION) SWITCH	78
BEFORE STARTING THE HYBRID SYSTEM	79
STARTING THE HYBRID SYSTEM	79
EV DRIVE MODE	83
DRIVING AND PARKING USING SMART ENTRY AND START SYSTEM	85
HYBRID TRANSMISSION	86
TURN SIGNAL LEVER	89
PARKING BRAKE	90
HORN	90
Instrument cluster	91
GAUGES AND METERS	91
INDICATORS AND WARNING LIGHTS	95
MULTI-INFORMATION DISPLAY	100
Operating the lights and wipers	116
HEADLIGHT SWITCH	116
AUTOMATIC HIGH BEAM	118
FRONT FOG LIGHTS	122
WINDSCREEN WIPERS AND WASHERS	122
Using other driving systems	126
CRUISE CONTROL	126
REAR VIEW MONITOR SYSTEM	128
TOYOTA PARKING ASSIST-SENSOR	133
BLIND SPOT MONITOR (BSM)	136
DRIVING ASSIST SYSTEMS	140
Driving Information	144
RUNNING-IN PERIOD	144
PRE-TRIP SAFETY CHECK	144
INFORMATION WHEN DRIVING IN VARIOUS CONDITIONS	145
WINTER DRIVING TIPS	150
INSTALLING SNOW TYRES AND CHAINS	151
TRAILER TOWING	152
CARGO AND LUGGAGE	157

Not for Reproduction

Driving procedures

Driving procedures



POWER (IGNITION) SWITCH

When the electronic key is inside the vehicle, pressing the POWER switch button allows you to:

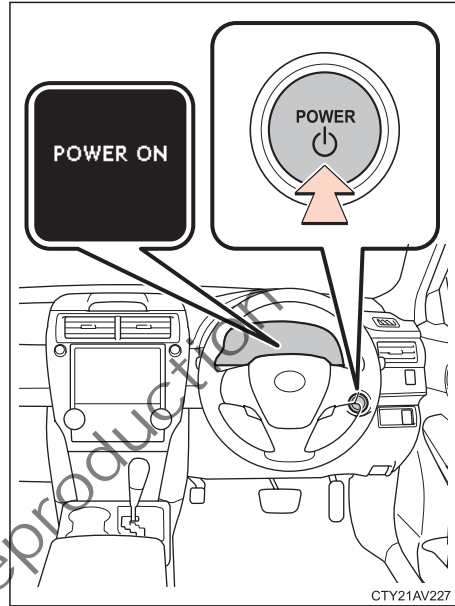
- Start or stop the hybrid system (with the brake pedal depressed)
- Select the ACCESSORY mode
- Select the ON mode
- Turn all modes OFF.



Without depressing the brake pedal, pressing the POWER switch slowly and firmly changes the POWER switch modes as follows:

	OFF	The emergency flashers can be used. The multi-information display will not be displayed.
First time	ACCESSORY mode  will be displayed on the screen.	Some electrical components such as the audio system can be used.
Second time	ON mode  will be displayed on the screen.	All electrical components can be used.
Third time *	Return to OFF	*NOTE: If the shift lever is in a position other P when turning off the hybrid system, the POWER switch will be turned to ACCESSORY mode, not to OFF.

 NOTICE

Do not leave the POWER switch in the ACCESSORY or ON mode if the hybrid system is not running. The 12-volt auxiliary battery will discharge and the ignition could be damaged.

If a buzzer sounds and / or a warning message is displayed on the multi-information display when pressing the POWER switch button, there may be a problem such as the electronic key is not in the vehicle or a door is open, etc., or there may be a malfunction of the smart entry and start system. Refer to “Driving and parking using smart entry and start system” on page 85.

BEFORE STARTING THE HYBRID SYSTEM

1. Check the area around the vehicle before entering it.
2. Check the seat position, seatback angle, seat cushion height, head restraint height, steering wheel angle and steering column length are all adjusted correctly.
3. Check the inside and outside rear view mirrors are adjusted correctly.
4. Lock all doors.
5. Fasten the seatbelts.

STARTING THE HYBRID SYSTEM

Push button start function

The hybrid system can be started by pressing the POWER switch.

Before starting the hybrid system, ensure to follow the instructions in “Before starting the hybrid system”.

Normal starting procedure.

When the electronic key is in the vehicle (on your person), it is possible to start the hybrid system.

1. Check that the parking brake is set.
2. Check the transmission shift lever is in the P position.
3. Depress the brake pedal firmly.



will be displayed on the multi-information display.

If it is not displayed, the hybrid system can not be started.

Driving procedures

4. Press the POWER switch slowly and firmly.

After a pause the READY indicator comes on while sounding a beep.

The vehicle can move when the READY indicator is on even if the petrol engine is stopped.

Continue depressing the brake pedal until the hybrid system is completely started.

The hybrid system can be started from any POWER switch mode.

If the ambient temperature is low, such as during winter driving conditions, it may take longer than the usual amount of time for the READY indicator to come on.

5. Check that the READY indicator is on. The vehicle will not move if the READY indicator is off.

If there is a problem in the hybrid system, the message CHECK ENTRY AND START SYSTEM will appear on the multi-information display. Have your vehicle checked by your Toyota dealer as soon as possible.

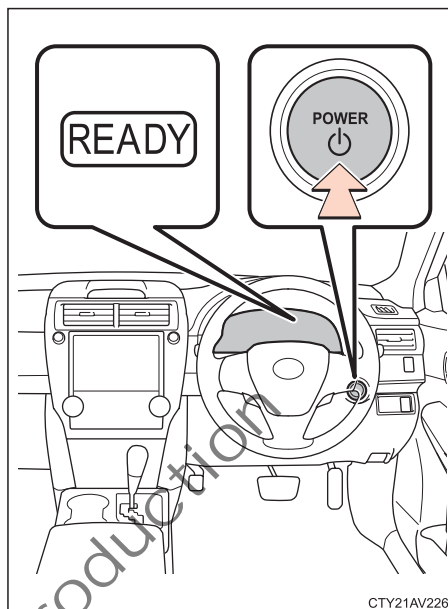



To stop the hybrid system

1. Stop the vehicle in a safe place.
2. Move the shift lever to P position.
3. Set the parking brake. Refer to "Parking brake" on page 90.
4. Press the POWER switch once.
5. Check that  on the multi-information display is off.

When stopping the hybrid system with the shift lever in a position other than P

If the hybrid system is stopped with the shift lever in a position other than P, the POWER switch will not be turned off but instead be turned to ACCESSORY mode. Perform the following procedure to turn the switch off.

1. Set the parking brake.
2. Move the shift lever to P position.
3. Check that  is displayed on the multi-information display and then press the POWER switch once.
4. Check that  on the multi-information display is off.

If the hybrid system does not start

- Check the shift lever is securely set in P position. The hybrid system will not start if the shift lever is in a position other than P.
- The immobiliser system may not have been deactivated. Refer to page 57.
- The key battery may be discharged. Refer to page 303.
- The smart entry and start system has been deactivated as a customised setting, refer to page 339.
- In addition to the above, there are instances in which the smart entry and start system does not operate correctly because of the circumstances of use. For details, refer to “Driving and parking using smart entry and start system” on page 85.

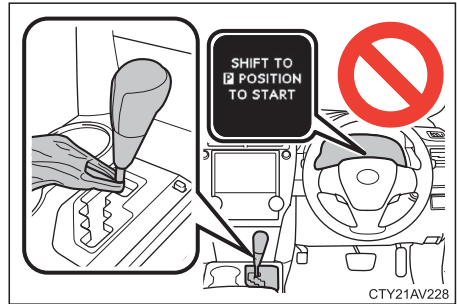

In cases other than those described above, it is possible that a problem has occurred in an area other than the start system. Refer to “If the hybrid system will not start” on page 319.

Auto power off function

If the vehicle is left in ACCESSORY or ON mode (the hybrid system is not running) for more than an hour with the shift lever in P position, the POWER switch will automatically turn off. However, this function cannot entirely prevent the 12-volt auxiliary battery discharging. Do not leave the vehicle with the POWER switch in ACCESSORY or ON mode for long periods of time while the hybrid system is not running.

Steering lock

After pressing the POWER switch off and opening and closing the doors, the steering wheel will be locked by the steering lock function. Pressing the POWER switch again automatically cancels the steering lock.

If the steering lock cannot be released, STEERING LOCK ACTIVE will be displayed on the multi-information display.

1. Check the shift lever is set in P position.
2. Press the POWER switch while turning the steering wheel left and right.

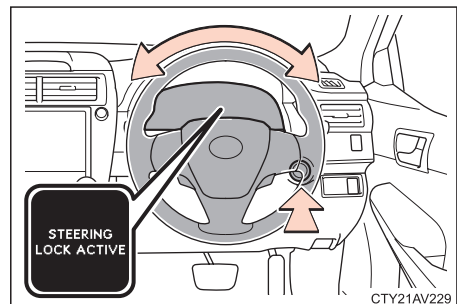

To prevent the steering lock motor from overheating, the motor may be suspended if the hybrid system is turned on and off repeatedly in a short period of time. In this case, refrain from operating the hybrid system.

After about 10 seconds, the steering lock motor will resume functioning.

Driving procedures

INFORMATION

If the **READY** indicator does not come on

If the **READY** indicator does not come on when you press the **POWER** switch with the shift lever in **P** position and the brake pedal depressed, contact your Toyota dealer immediately.

Operation of the **POWER** switch

- When operating the **POWER** switch, one short, firm press is enough. If the switch is pressed incorrectly, the hybrid system may not start or the **POWER** switch mode may not change. It is not necessary to press and hold the switch.
- If attempting to restart the hybrid system immediately after pressing the **POWER** switch off, the hybrid system may not start in some cases.

After pressing the **POWER** switch off, wait a few seconds before restarting the hybrid system.

CAUTION

When starting the hybrid system

Always start the hybrid system while sitting in the driver's seat. Do not depress the accelerator pedal while starting the hybrid system under any circumstances.

Doing so may cause an accident resulting in death or serious injury.

Caution when driving

If a hybrid system failure occurs while the vehicle is moving, do not lock or open the doors until the vehicle reaches a safe and complete stop. Activation of the steering lock in this circumstance may lead to an accident, resulting in death or serious injury.

Stopping the hybrid system in an emergency

If you need to stop the hybrid system in an emergency while driving the vehicle, press and hold the **POWER** switch for more than 3 seconds, or press it briefly three times or more in succession.

However, do not touch the **POWER** switch while driving except in an emergency.

Turning the hybrid system off while driving will not cause loss of steering or braking control, but the power assistance to these systems will be lost making it more difficult to steer and brake. Pull over and stop the vehicle as soon as it is safe to do so.

Refer to "If your vehicle has to be stopped in an emergency" on page 328.

NOTICE

To prevent 12-volt auxiliary battery discharge

- Do not leave the POWER switch in ACCESSORY or ON mode for long periods of time without the hybrid system on.
- If  is displayed on the multi-information display, the POWER switch is not off. Exit the vehicle after pressing the POWER switch off.
- Do not stop the hybrid system when the shift lever is in a position other than P. If the hybrid system is stopped in another shift lever position, the POWER switch will not be turned off but instead be turned to ACCESSORY mode. If the vehicle is left in ACCESSORY mode, 12-volt auxiliary battery discharge may occur.

When starting the hybrid system

- Do not depress the accelerator pedal unnecessarily.

Symptoms indicating a malfunction with the POWER switch

If the POWER switch seems to be operating somewhat differently than usual, such as the switch sticking slightly, there may be a malfunction. Contact your Toyota dealer immediately.

EV DRIVE MODE

In EV drive mode the electric motor, powered by the hybrid battery, is used to drive the vehicle.

This mode allows you to drive in residential areas early in the morning and late at night, or in indoor parking lots etc. without concern for noises and exhaust gas emissions.

1. Press to turn the EV drive mode on.
2. Press again to turn the EV drive mode off.

When EV drive mode is turned on, the EV drive mode indicator will come on. Pressing the switch when in EV drive mode will return the vehicle to normal driving (using the petrol engine and electric motor).

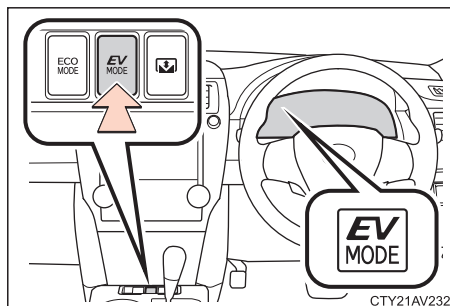

Situations in which EV drive mode cannot be turned on

It may not be possible to turn EV drive mode on in the following situations. If it cannot be turned on, a buzzer will sound and a message will be shown on the multi-information display.

- The temperature of the hybrid system is high. The vehicle has been left in the sun, driven up a hill, driven at high speeds, etc.

Driving procedures

- The temperature of the hybrid system is low. The vehicle has been left in temperatures lower than about 20°C for a long period of time etc.
- The petrol engine is warming up.
- The hybrid battery charge level is low. The remaining battery level indicated in the ENERGY MONITOR display is low. Refer to “Energy monitor” on page 8.
- Vehicle speed is about 45 km/h or more.
- The accelerator pedal is depressed firmly or the vehicle is travelling up a hill etc.
- The windscreen defogger is in use.

Switching to EV drive mode when the petrol engine is cold

If the hybrid system is started while the petrol engine is cold, the petrol engine will start automatically after a short period of time to enable it to warm up. In this situation, you will be unable to switch to EV drive mode.

After the hybrid system has started and the READY indicator has illuminated, press the EV drive mode switch before the petrol engine starts to switch to EV drive mode.

Automatic cancellation of EV drive mode

When driving in EV drive mode, the petrol engine may automatically restart in the following situations. When EV drive mode is cancelled, a buzzer will sound and the EV drive mode indicator will flash and go off.

- The hybrid battery charge level becomes low. The remaining battery level indicated in the ENERGY MONITOR display is low. “Energy monitor” on page 8.
- The vehicle speed becomes more than about 45 km/h. EV drive mode may be automatically cancelled when vehicle speed reaches about 30 km/h if the engine coolant temperature is low.
- The accelerator pedal is depressed firmly or the vehicle is travelling up a hill etc.

Possible travelling distance when driving in EV drive mode

EV drive mode's possible travelling distance ranges from a few hundred meters to approximately 2 km. Driving is possible at speeds of less than approximately 45 km/h. However, depending on vehicle conditions, there are situations when EV drive mode cannot be used.

(The distance that is possible depends on the hybrid battery charge level and driving conditions.)

Fuel economy

Your Toyota is designed to achieve the best possible fuel economy during normal driving (using the petrol engine and electric motor). Driving in EV drive mode more than necessary may have an adverse effect on the fuel economy.

CAUTION

When driving in EV drive mode, pay special attention to the area around the vehicle. Because there is no engine noise, pedestrians, people riding bicycles or other people and vehicles in the area may not be aware of the vehicle starting off or approaching them, so take extra care while driving.

DRIVING AND PARKING USING SMART ENTRY AND START SYSTEM

Tips for using smart entry and start system

When using the smart entry and start system, it is possible to start or stop the hybrid system as long as the key is on your person.

For this reason, it is possible that a passenger may remove the key from the vehicle without the driver being aware of the fact. In such a case, it is not possible to restart the hybrid system after having turned it off. In addition, it is possible that a person may get out of the vehicle without being aware the POWER switch has not been turned off completely.

For smart entry and start system warning messages and reminders refer to "Warning messages" on page 100.

NOTICE

When driving or getting in or out of the vehicle, driver's should make sure they are carrying the key.

CAUTION

Do not touch the POWER switch while driving.

NOTICE

If you have to make an emergency stop, press and hold the POWER switch for more than 3 seconds, while fully depressing the brake pedal.

Not for reproduction

Driving procedures

HYBRID TRANSMISSION

Select a shift position appropriate for the driving conditions.

Shifting the selector lever

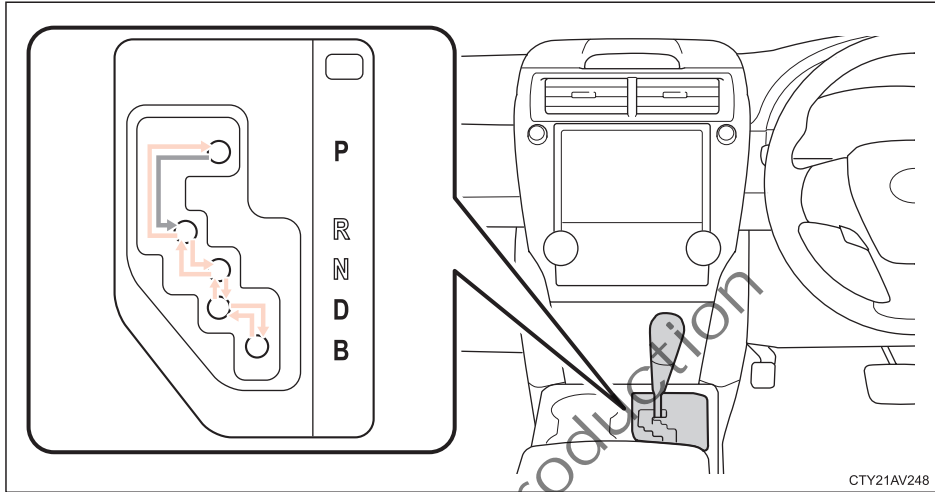

← While the POWER switch is in ON mode, move the shift lever with the brake pedal depressed.

When shifting the shift lever between P and D positions, make sure that the vehicle is completely stopped.

Selector lever positions

The shift position is also displayed on the instrument cluster.

Shift position	Function
P	Parking the vehicle / starting the hybrid system
R	Reversing
N	Neutral
D	Normal driving
B	Position for engine braking

Normal driving

1. Start the hybrid system as instructed in "Starting the hybrid system" on page 79. The transmission must be in **P position**.
2. With your foot holding down the brake pedal, shift the selector lever to **D position**.
3. Release the parking brake and brake pedal. Depress the accelerator pedal slowly for smooth starting.

⚠ CAUTION

- Never put your foot on the accelerator pedal while shifting the selector lever.
- Always keep your foot on the brake pedal while stopped with the hybrid system on. This prevents the vehicle from creeping.

⚠ NOTICE

Always use the brake pedal or the parking brake to hold the vehicle on an incline. Do not attempt to hold the vehicle using the accelerator pedal, as this can cause the transmission to overheat.

Using engine braking

To use engine braking, shift the lever to **B position** and take your foot off the accelerator pedal.

- During high speed driving, you may feel that engine braking is less effective than that of conventional vehicles.
- Do not continue normal driving with the transmission in B position for long periods. This may cause decreased fuel economy.

⚠ CAUTION

Be careful when using engine braking on a slippery surface. Abrupt shifting could cause the vehicle to spin or skid.

Reversing

1. Bring the vehicle to a complete stop.
2. With the brake pedal held down with your foot, shift the selector lever to the **R position**.

⚠ NOTICE

Never shift into reverse while the vehicle is moving.

Parking

1. Bring the vehicle to a complete stop.
2. With the brake pedal pressed down, fully apply the parking brake.
3. With the brake pedal pressed down, shift the selector lever to the **P position**.
4. When turning the hybrid system off, ensure the transmission is in P position.

⚠ CAUTION

Never attempt to move the selector lever into P position under any circumstances while the vehicle is moving. Serious mechanical damage and loss of vehicle control may result.

Driving procedures

If you cannot shift the selector lever out of P position

If you cannot shift the selector lever from P position even though the brake pedal is depressed, use the shift lock override button. For instructions, refer to “If the shift lever cannot be moved from P position” on page 320.

Selecting Eco drive mode

When the vehicle is driven in Eco drive mode, vehicle driving force and operation of the air conditioning system (heating / cooling) is controlled to improve fuel efficiency.

Eco drive mode

When eco drive mode is turned on, the ECO MODE indicator will come on.

Pressing the ECO MODE switch again turns eco drive mode off.

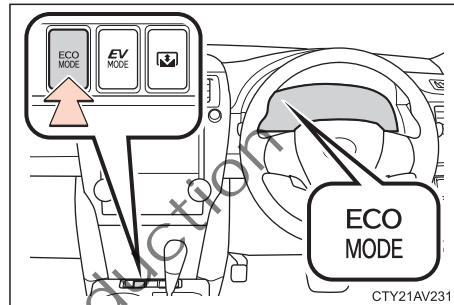

INFORMATION

Operation of the air conditioning system in Eco drive mode

Eco drive mode controls the heating / cooling operations and fan speed of the air conditioning system to enhance fuel efficiency, refer to “Selecting Eco drive mode” on page 88. To improve air conditioning performance, adjust the fan speed or turn off Eco drive mode.

When in heavy traffic

If the shift lever is in N position, the hybrid battery will not be charged. To help prevent the battery from discharging, avoid putting the shift lever in N position for an extended period of time.

If the shift lever cannot be shifted from P position

Refer to “If the shift lever cannot be moved from P position” on page 320.

! CAUTION

When driving on slippery road surfaces

Do not accelerate or shift gears suddenly. Sudden changes in engine braking may cause the vehicle to spin or skid, resulting in an accident.

Efficient driving

- Shift the shift lever to D position when driving.
In the N position, the petrol engine operates but electricity cannot be generated. The hybrid battery will discharge, requiring unnecessary engine power to recharge.
- Drive your vehicle smoothly.
Avoid abrupt acceleration and deceleration. Gradual acceleration and deceleration will make more effective use of the electric motor without having to use petrol engine power.
- Avoid repeated acceleration.
Repeated acceleration consumes hybrid battery (traction battery) power, resulting in poor acceleration. Battery power can be restored by driving with the accelerator pedal slightly released.
- Shift the shift lever to P position when parking.
In the N position, the hybrid battery does not recharge. Leaving the shift lever in the N position for an extended period of time may discharge the hybrid battery. The vehicle cannot run if the hybrid battery is discharged.

TURN SIGNAL LEVER

The POWER switch must be in ON mode.

1. Left turn.
2. Right turn.
3. Move and hold the lever partway to signal a lane change.
The left hand signal will flash until you release the lever.
4. Move and hold the lever partway to signal a lane change.
The right hand signal will flash until you release the lever.

If the turn signal indicator lights on the instrument cluster flash faster than normal, a turn signal bulb is burned out. Refer to "Light bulbs" on page 291.

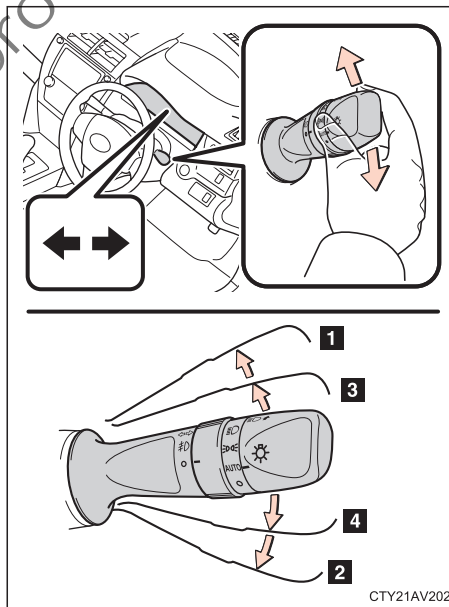

CTY21AV202

Driving procedures

PARKING BRAKE

When parking, firmly apply the parking brake to avoid inadvertent creeping.

To set:

While depressing the brake pedal with your right foot, depress the parking brake pedal with your left foot.

To release:

Depress the parking brake pedal again.

To remind you the parking brake is set, the parking brake reminder light in the instrument cluster remains on until you fully release the parking brake pedal.

If the vehicle speed rises above 5 km/h (with the parking brake remaining set) a buzzer will sound. Stop the vehicle and release the parking brake fully.

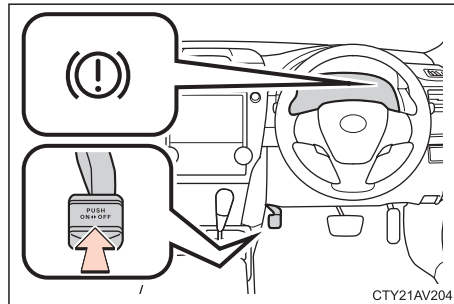

⚠ CAUTION

Before driving, ensure the parking brake is fully released and the parking brake reminder light is off.

HORN

To sound the horn, press on or close to the horn symbol on the steering wheel pad.

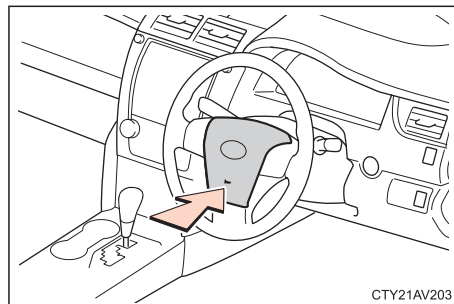

Instrument cluster

GAUGES AND METERS

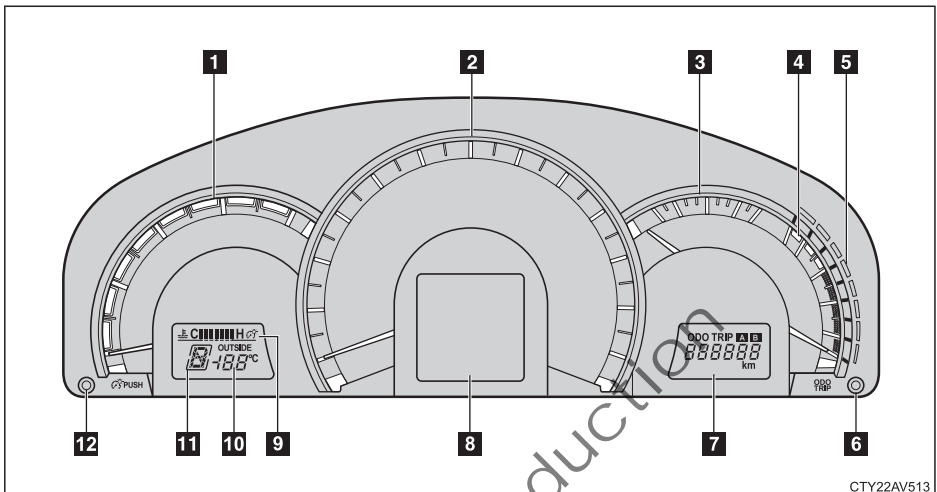

1	Hybrid system indicator	Displays hybrid system power output and regenerative level
2	Speedometer	Displays the vehicle speed.
3	Fuel gauge	Displays the quantity of fuel remaining in the tank.
4	Average fuel consumption meter	Displays the average fuel consumption since the function was reset.
5	Current fuel consumption gauge	Displays the current rate of fuel consumption.
6	Display change button	Changes the odometer / trip meter display. Refer to page 92.
7	Odometer / trip meter display	Displays the odometer or trip meters. Refer to page 92.
8	Multi-information display	Displays a variety of driving related data. Refer to page 111.
9	Engine coolant temperature display / instrument panel lights control display	Displays the engine coolant temperature and instrument cluster lights control.
10	Outside temperature display	Displays the outside temperature. Refer to page 93.
11	Shift position display	Displays the currently selected shift position.
12	Meter panel lights control button	Adjusts the brightness of the meter panel lights. Refer to page 93.

NOTICE

To prevent damage to the engine and its components

The engine may be overheating if the rightmost segment of the engine coolant temperature display is flashing. In this case, immediately stop the vehicle in a safe place, and check the engine after it has cooled completely.

Refer to “If your vehicle overheats” on page 325.

Odometer / trip meter display

Pressing the button changes the display as follows.

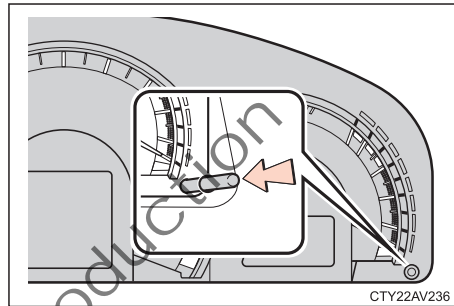

- Odometer



Displays the total distance the vehicle has been driven.

- Trip meters A and B



Displays the distance the vehicle has been driven since the meter was last reset. Trip meters A and B can be used to record and display different distances independently.

Press and hold the button to reset.



Fuel gauge and odometer/trip meter display remain on mode

After the POWER switch has been pressed off, the fuel gauge and odometer/ trip meter display remain on for 10 minutes, enabling the fuel gauge and odometer/trip meter values to be checked again without having to press the POWER switch to ON mode.

When confirming the gauges and meters, turn the headlight switch to the $\Rightarrow \text{D} \text{D} \Leftarrow$ position. Press the display change button to change between the odometer and trip meter displays.

Instrument cluster light control button

The brightness of the instrument cluster lights can be adjusted by pressing the button.

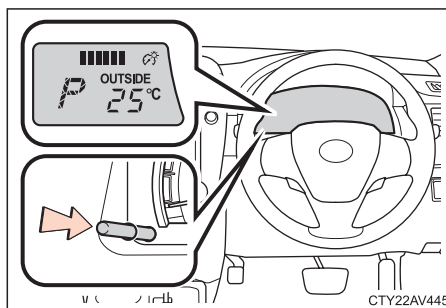

INFORMATION

The instrument cluster lights illuminate when the POWER switch is in ON mode

Instrument cluster light brightness

- When the headlight switch is in a position other than off, the brightness will be reduced slightly unless the brightness level adjustment is set to the brightest setting.
- If the headlight switch is in a position other than off when the surroundings are dark, the brightness will reduce slightly. However, when the surroundings are bright, such as during the daytime, the brightness will not be reduced.

Instrument panel lights

- The instrument panel lights will illuminate only when the headlight switch is in a position other than off.

Clock

- The clock illuminates when the POWER switch is in ON mode.
- When the headlight switch is in a position other than off, the brightness of the clock will be reduced slightly.

Outside temperature display

The temperature display shows temperatures within the range of -40°C and 50°C.

The outside temperature is displayed when the POWER switch is in ON mode.

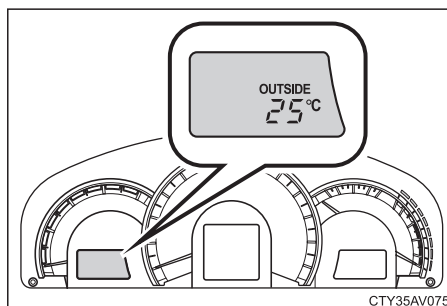

Instrument cluster

In the following situations, the correct outside temperature may not be displayed, or the display may take longer than normal to change:

- When the vehicle is stopped, or moving at low speeds (less than 25 km/h.)
- When the outside temperature has changed suddenly (at the entrance/ exit of a garage, tunnel, etc.)

When E is displayed the system may be malfunctioning. Take your vehicle to your Toyota dealer.

Hybrid system indicator

1. Power area.
Shows that the driving power is more than the upper limit of Eco driving (during full power driving etc.)
2. Eco area.
Shows that the vehicle is being driven in an Eco-friendly manner.
3. Hybrid Eco area.
Shows that petrol engine power is not being used very often.
The petrol engine will automatically stop and restart under various conditions.
4. Charge area.
Shows regenerative charging.

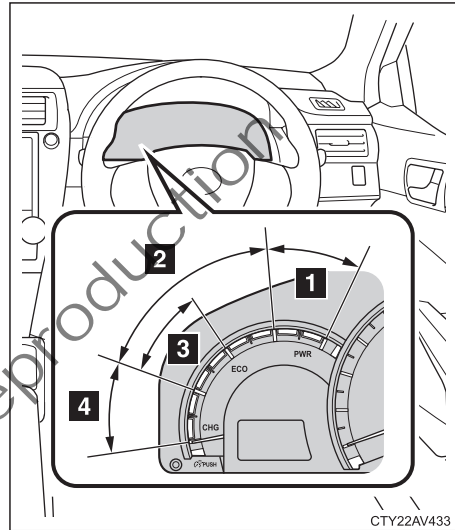

- By keeping the indicator needle within Eco area, more Eco-friendly driving can be achieved.
- Charge area indicates regeneration* status. Regenerated energy will be used to charge the battery.

*: When used in this manual, "regeneration" refers to the conversion of energy created by the movement of the vehicle into electrical energy.

INFORMATION

Engine speed

On hybrid vehicles, engine speed is precisely controlled in order to help improve fuel efficiency and reduce exhaust emissions etc.

There are times when the engine speed that is displayed may differ even when vehicle operation and driving conditions are the same.

INDICATORS AND WARNING LIGHTS

The indicators and warning lights on the instrument cluster, centre panel and outside rear view mirrors inform the driver of the status of the vehicle's various systems.

Instrument cluster

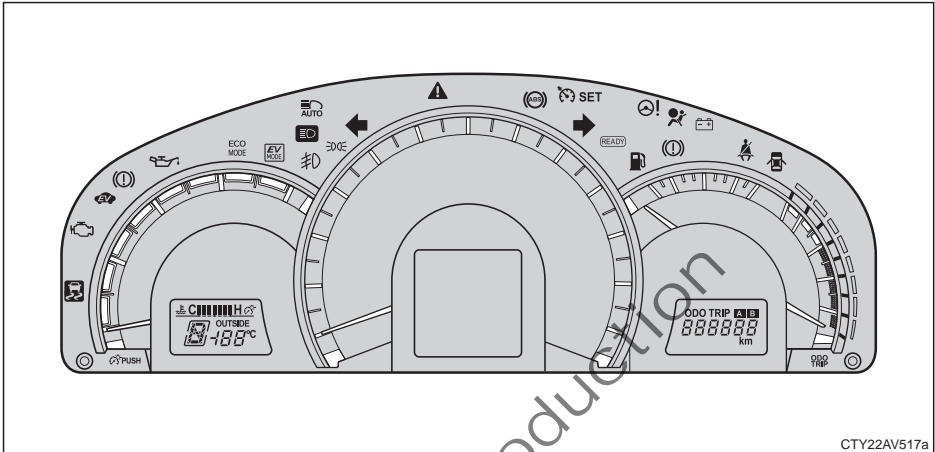

Indicators–

- The indicators inform the driver of the operating state of the vehicle's various systems.

	Turn signal indicator (page 89)		Cruise control indicator (page 126)
	Headlight high beam indicator (page 116)		Cruise control set indicator (page 126)
	Automatic high beam indicator (page 118) *		ECO MODE indicator (page 88)
	Tail light indicator (page 116)		EV indicator (page 83)
	Front fog light indicator (page 122)		EV drive mode indicator (page 83)
	Shift position and shift range indicators (page 86)		Driving ready indicator (page 79)
	Slip indicator (page 140) *		





*: These indicator lights illuminate when the POWER switch is pressed to ON mode to indicate a system check is being performed. They turn off after the hybrid system is started, or after a few seconds.







Instrument cluster

There may be a malfunction in a system if a light does not come on, or if the lights do not turn off. Have the vehicle inspected by your Toyota dealer.





Warning lights–

- Warning lights inform the driver of malfunctions in any of the vehicle's systems.

Warning Light	Details
	<p>Brake system warning light in red and buzzer*</p> <ul style="list-style-type: none"> • Illuminates when the parking brake is engaged, if the brake fluid level is low or there is a malfunction in the brake system. • The light also illuminates and the buzzer sounds if the park brake is engaged and the vehicle speed exceeds 5 km/h. <p>If the parking brake is off, stop immediately and contact your Toyota dealer.</p> <p>NOTE: Depressing the brake pedal repeatedly may cause the red brake system warning light to turn on and the buzzer to sound, this does not indicate a malfunction.</p>
	<p>Brake system warning light in yellow</p> <p>Indicates a malfunction in:</p> <ul style="list-style-type: none"> • The regenerative brake system, or • The electronically controlled brake system.
	<p>Charging system warning light*</p> <ul style="list-style-type: none"> • Indicates a malfunction in the vehicle's charging system. <p>Stop immediately and contact your Toyota dealer.</p>
	<p>Low engine oil pressure warning light*</p> <ul style="list-style-type: none"> • Indicates the engine oil pressure is too low. <p>Stop immediately and check.</p>
	<p>High engine coolant temperature warning light (the right-most segment of the engine coolant temperature display flashes)</p> <ul style="list-style-type: none"> • Indicates the engine is almost overheating. <p>Stop immediately and contact your Toyota dealer.</p>

Warning Light	Details
	<p>Malfunction indicator warning light*</p> <ul style="list-style-type: none"> Indicates a malfunction in: <ul style="list-style-type: none"> The hybrid system; or The electronic engine control system; or The electronic throttle control system; or The hybrid transmission control system. <p>Stop immediately and contact your Toyota dealer</p> <ul style="list-style-type: none"> It may also illuminate when the fuel tank is completely empty, refer to “If the malfunction indicator warning light comes on while driving” on page 311.
	<p>SRS warning light*</p> <ul style="list-style-type: none"> Indicates a malfunction in: <ul style="list-style-type: none"> The SRS airbag system; or The seatbelt pretensioner system <p>Stop immediately and contact your Toyota dealer</p>
	<p>ABS warning light*</p> <ul style="list-style-type: none"> Indicates a malfunction in: <ul style="list-style-type: none"> The ABS; or The brake assist system. <p>Stop immediately and contact your Toyota dealer</p>
	<p>Electric power steering warning light and buzzer*</p> <ul style="list-style-type: none"> Indicates a malfunction in the EPS system. <p>Stop immediately and contact your Toyota dealer</p> <p>NOTE: When the 12-volt auxiliary battery charge becomes insufficient or the voltage temporarily drops, the electric power steering system warning light may come on and the warning buzzer may sound.</p>
	<p>Slip indicator warning light*</p> <ul style="list-style-type: none"> Indicates a malfunction in: <ul style="list-style-type: none"> VSC system; or TRC system; or Hill-start assist control. The indicator flashes to indicate the system is operating. <p>Stop immediately and contact your Toyota dealer</p>
	<p>Automatic high beam warning light (illuminates yellow)</p> <ul style="list-style-type: none"> Indicates a malfunction in the automatic high beam system. <p>Stop immediately and contact your Toyota dealer</p>

Instrument cluster

Warning Light	Details
	<p>Open door warning light and buzzer</p> <ul style="list-style-type: none"> Indicates a door or the boot lid is not fully closed. The buzzer sounds if a door or the boot lid is not fully closed and the vehicle speed exceeds 5 km/h. <p>Check all doors and the boot lid are closed</p>
	<p>Driver and front passenger seatbelt warning light and buzzer</p> <ul style="list-style-type: none"> Warns the driver and/or front passenger their seatbelt is not fastened. The buzzer sounds for 30 seconds if the driver and/or front passenger has not fastened their seatbelt and the vehicle speed exceeds 20 km/h. After 30 seconds if the seatbelt remains unfastened the buzzer will sound a different tone for a further 90 seconds. <p>Fasten the seatbelt</p>
	<p>Low fuel warning light</p> <ul style="list-style-type: none"> Indicates remaining fuel is approximately 10.5 L or less. <p>Refuel the vehicle</p>
	<p>Master warning light</p> <p>A buzzer sounds and the warning light comes on and flashes to indicate that the master warning system has detected a malfunction.</p> <p>Refer to “Multi-information display” on page 100.</p>

*: These warning lights illuminate when the POWER switch is pressed to ON mode to indicate a system check is being performed. They turn off after the hybrid system is started, or after a few seconds.

There may be a malfunction in a system if a light does not come on, or if the lights do not turn off. Have the vehicle inspected by your Toyota dealer.

CAUTION

When the electric power steering system warning light comes on the steering wheel may become extremely heavy.

If the steering wheel becomes heavier than usual, grip the steering wheel firmly and operate using more force than usual to steer the vehicle to a safe stop.

Centre panel

Indicator–

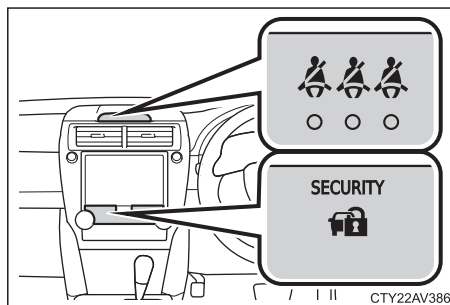
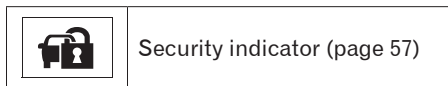

Warning light–

Warning Light	Details
	<p>Rear passenger seatbelt warning lights and buzzer</p> <ul style="list-style-type: none"> Warns the rear passengers their seatbelt is not fastened. The buzzer sounds for 30 seconds if a rear seat passenger has not fastened their seatbelt and the vehicle speed exceeds 20 km/h. After 30 seconds if the seatbelt remains unfastened the buzzer will sound a different tone for a further 90 seconds. <p>Fasten the seatbelt</p>

Outside rear view mirrors

Indicator–

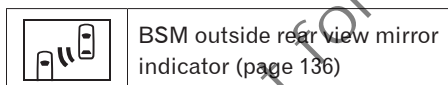

In order to confirm its operation, the BSM outside rear view mirror indicators illuminate in the following situations.

- When the POWER switch is pressed to ON mode with the BSM main switch set to ON.
- When the BSM main switch is set to ON with the POWER switch in ON mode.

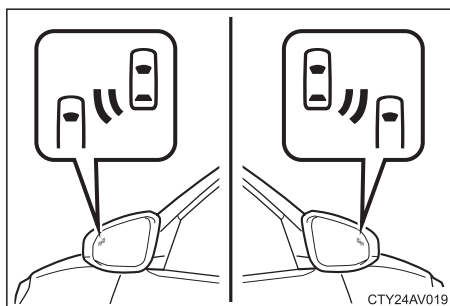

If the system is functioning correctly, the BSM outside rear view mirror indicators will turn off after a few seconds.

CAUTION**If a safety system warning light does not illuminate**

Should a safety system warning light such as the ABS or SRS warning light not illuminate when you start the hybrid system, this could mean these systems are not available to help protect you in an accident, which could result in death or serious injury. Have the vehicle inspected by your Toyota dealer immediately should this occur.

Instrument cluster

MULTI-INFORMATION DISPLAY

The multi-information display presents the driver with a variety of driving-related data.

- Warning messages (refer to below).

Automatically displayed when a malfunction occurs in one of the vehicle's systems.

- Trip information, refer to "Trip information" on page 112.

Displays cruising range, fuel consumption and other cruising-related information.

- Toyota parking assist-sensor display, refer to "Toyota parking assist-sensor" on page 133.

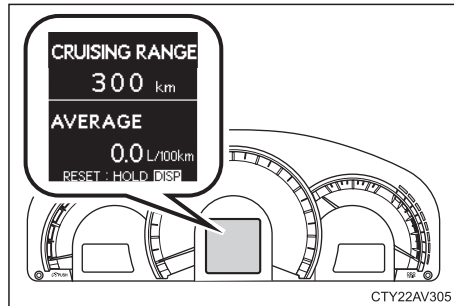

Warning messages

1. Master warning light.

The master warning light also comes on or flashes in order to indicate that a message is currently being displayed on the multi-information display. Refer to the following pages.

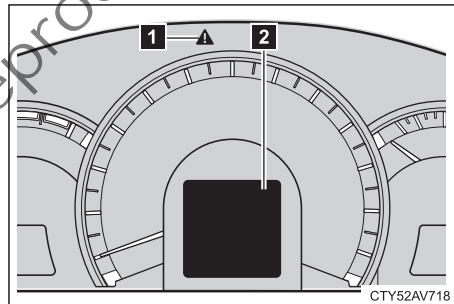

2. Multi-information display.



If a warning is shown on the multi-information display, stay calm and perform the following actions. If any of the warning lights comes on again after the following actions have been performed, contact your Toyota dealer.







Stop the vehicle immediately–

A buzzer sounds and a warning message is shown on the multi-information display. The following warning indicates the possibility of damage to the vehicle that may lead to an accident. Immediately stop the vehicle in a safe place and contact your Toyota dealer.

Warning message	Details
 	<p>Indicates a malfunction in the hybrid system.</p> <p>A buzzer also sounds.</p>

Have the vehicle inspected immediately–





A buzzer sounds and a warning message is shown on the multi-information display. Failure to investigate the cause of the following warnings may lead to the system operating abnormally and possibly cause an accident. Have the vehicle inspected by your Toyota dealer immediately.





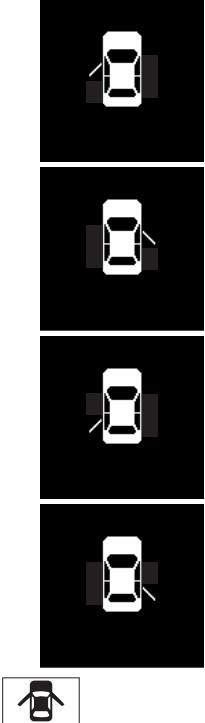





Warning message	Details
  (Flashes)	<ul style="list-style-type: none"> • Indicates a malfunction in the steering lock system. • Indicates a malfunction in the smart entry & start system. <p>A buzzer also sounds.</p>
 	<p>Indicates a malfunction in the cruise control system.</p>
 	<p>Indicates a malfunction in the Blind Spot Monitor.</p>

Instrument cluster

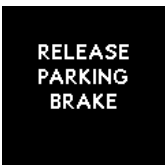

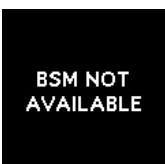

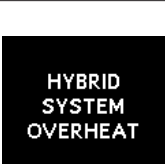



Follow the correction procedures—



A buzzer sounds and a warning message is shown on the multi-information display. After taking the specified steps to correct the suspected problem, check that the warning message goes off.

Warning message	Details	Correction procedure
	<p>Indicates that one or more of the doors is not fully closed.</p> <p>The system also indicates which doors are not fully closed.</p> <p>If the vehicle reaches a speed of 5 km/h,  flashes and a buzzer sounds to indicate that the door(s) are not yet fully closed.</p>	<p>Make sure that all the doors are closed.</p>
<p>HOOD OPEN</p> 	<p>Indicates that the bonnet is not fully closed.</p> <p>If the vehicle reaches a speed of 5 km/h,  flashes and a buzzer sounds to indicate that the bonnet is not yet fully closed.</p>	<p>Close the bonnet.</p>

Warning message	Details	Correction procedure
 	<p>Indicates that the boot is not fully closed.</p> <p>If the vehicle reaches a speed of 5 km/h,  flashes and a buzzer sounds to indicate that the boot is not yet fully closed.</p>	<p>Close the boot</p>
  (Flashes)	<p>Indicates that the moon roof is not fully closed (with the POWER switch off and the driver's door opened).</p>	<p>Close the moon roof.</p>
   (Flashes)	<p>Indicates, if the vehicle reaches a speed of 5 km/h, that the parking brake is still engaged.</p> <p>A buzzer also sounds.</p>	<p>Release the parking brake,</p>
 	<p>Indicates that the Blind Spot Monitor sensors or the surrounding area on the bumper is dirty or covered with ice.</p>	<p>Clean the sensor and its surrounding area on the bumper.</p>
 	<p>Indicates that the hybrid system has overheated.</p> <p>Indicates that the hybrid system has overheated. This message may be displayed when driving under severe operating conditions. (For example, when driving up a long steep hill.)</p>	<p>Stop and check. Refer to page 325.</p>

Instrument cluster



Warning message	Details	Correction procedure
  (Flashes)	<p>Indicates that the hybrid battery is low.</p> <p>A buzzer also sounds.</p>	<p>When stopping the vehicle for a long period of time, shift the shift lever to P. The hybrid battery cannot be charged with the shift position in N.</p>
  (Flashes)	<p>Indicates that the hybrid battery power has dropped because an extended period of time has elapsed after shifting the shift lever to N.</p> <p>A buzzer also sounds.</p>	<p>Restart the hybrid system when starting the vehicle.</p>
  (Flashes)	<p>Indicates that the driver's door was opened with the shift position in any position other than P.</p> <p>A buzzer also sounds.</p>	<p>Move the shift lever to P position.</p>
  (Flashes)	<p>Indicates that the accelerator pedal is depressed while the shift position is in N.</p> <p>A buzzer also sounds.</p>	<p>Release the accelerator pedal and shift the shift lever to D, B or R position.</p>
	<p>Indicates that the EV drive mode is not available.*</p> <p>A buzzer also sounds.</p> <p>The reason the EV drive mode is not available (the vehicle is idling, battery charge is low, speed is higher than the EV drive mode operating speed range, accelerator pedal is depressed too much) may be displayed.</p>	<p>Use the EV drive mode when it becomes available.</p>

Warning message	Details	Correction procedure
  (Flashes 3 times)	<p>Indicates that the EV drive mode has been automatically cancelled.*</p> <p>A buzzer also sounds. The reason the EV drive mode is not available (the battery charge is low, speed is higher than the EV drive mode speed range, accelerator pedal is depressed too much) may be displayed.</p>	<p>Drive the vehicle for an extended time.</p>

*: Refer to "EV drive mode" on page 83 for more details.







Rectify the malfunction immediately—

After taking the specified steps to correct the suspected problem, check that the warning message and light go off.







Interior buzzer	Exterior buzzer	Warning message	Details	Correction procedure
Once	—	  (Flashes)	<p>The electronic key is not detected when an attempt is made to start the hybrid system.</p>	<p>Start the hybrid system with the electronic key present.</p>





Instrument cluster

Interior buzzer	Exterior buzzer	Warning message	Details	Correction procedure
Once	3 times	<div data-bbox="349 443 512 609" style="background-color: black; color: white; padding: 5px; text-align: center; margin-bottom: 5px;">KEY NOT DETECTED</div> <div data-bbox="311 619 389 667" style="display: inline-block; border: 1px solid black; padding: 2px;">  </div> (Flashes)	The electronic key was carried outside the vehicle and a door other than the driver's door was opened and closed while the POWER switch was in a mode other than off.	Bring the electronic key back into the vehicle.
		<div data-bbox="349 896 512 1062" style="background-color: black; color: white; padding: 5px; text-align: center; margin-bottom: 5px;">KEY NOT DETECTED</div> <div data-bbox="349 1066 512 1232" style="background-color: black; color: white; padding: 5px; text-align: center;">TURN POWER OFF</div> (Displayed alternatively)	The electronic key was carried outside the vehicle and the driver's door was opened and closed while the shift lever in P position was selected without pressing off the POWER switch.	Press the POWER switch off or bring the electronic key back into the vehicle.
Once	Continuous	<div data-bbox="349 896 512 1062" style="background-color: black; color: white; padding: 5px; text-align: center; margin-bottom: 5px;">KEY NOT DETECTED</div> <div data-bbox="349 1066 512 1232" style="background-color: black; color: white; padding: 5px; text-align: center;">TURN POWER OFF</div> (Displayed alternatively)	An attempt was made to exit the vehicle with the electronic key and lock the doors without first pressing the POWER switch off.	Press the POWER switch off and lock the doors again.







Interior buzzer	Exterior buzzer	Warning message	Details	Correction procedure
9 times	—	  (Flashes)	<p>An attempt was made to start the hybrid system without the electronic key being present, or the electronic key was not functioning normally.</p> <p>An attempt was made to drive when the regular key was not inside the vehicle.</p>	Confirm that the electronic key is inside the vehicle.
Continuous	—	  (Flashes)	The driver's door was opened while any shift lever position other than P was selected without pressing off the POWER switch.	Change the shift lever to P position.
Continuous	Continuous	  (Displayed alternatively)  (Flashes)	The electronic key was carried outside the vehicle and the driver's door was opened and closed while any shift lever position other than P was selected without pressing off the POWER switch.	<ul style="list-style-type: none"> • Change the shift lever to P position. • Bring the electronic key back into the vehicle.



Instrument cluster

Interior buzzer	Exterior buzzer	Warning message	Details	Correction procedure
Once	Continuous	  (Flashes)	An attempt was made to lock the doors using the smart entry & start system while the electronic key was still inside the vehicle.	Retrieve the electronic key from the vehicle and lock the doors again.
Once	Continuous	  (Flashes)	An attempt was made to lock either front door by opening a door and putting the inside lock button into the lock position, then closing the door by pulling on the outside door handle with the electronic key still inside the vehicle.	Retrieve the electronic key from the vehicle and lock the doors again.
Once	—	  (Flashes)	<ul style="list-style-type: none"> When the doors were unlocked with the mechanical key and then the POWER switch was pressed, the electronic key could not be detected in the vehicle. The electronic key could not be detected in the vehicle even after the POWER switch was pressed two consecutive times. 	Touch the electronic key to the POWER switch while depressing the brake pedal.

Interior buzzer	Exterior buzzer	Warning message	Details	Correction procedure
Once	—	  (Flashes)	An attempt was made to start the hybrid system with the shift lever in N position.	Change the shift lever to P position and start the hybrid system.
—	—		Power was turned off due to the automatic power off function.	Next time when starting the hybrid system, increase the engine speed slightly and maintain that level for approximately 5 minutes to recharge the 12-volt auxiliary battery.
Once	—	 	The electronic key has a low battery.	Replace the electronic key battery. Refer to “Replacing the remote control transmitter battery” on page 303.

Instrument cluster

Interior buzzer	Exterior buzzer	Warning message	Details	Correction procedure
Once	—	  (Flashes)	The driver's door was opened and closed with the POWER switch turned off and then the POWER switch was put in ACCESSORY mode twice without the hybrid system being started.	Press the POWER switch while depressing the brake pedal.
			During a hybrid system starting procedure, the electronic key was not functioning properly and the POWER switch was touched with the electronic key. Refer to "If the electronic key does not operate properly" on page 321.	Press the POWER switch within 10 seconds of the buzzer sounding.
Once	—	  (Flashes)	The steering lock could not be released within 3 seconds of the POWER switch being pressed.	Press the POWER switch while depressing the brake pedal and moving the steering wheel left and right.
Once	—	  (Flashes)	The POWER switch has been pressed off with the shift lever in a position other than P.	Change the shift lever to P position.

Interior buzzer	Exterior buzzer	Warning message	Details	Correction procedure
Once	—	  (Flashes)	After the POWER switch has been pressed off with the shift lever in a position other than P, the shift lever has been shifted to P position.	Press the POWER switch off.

NOTE: DRIVING FORCE LIMITED displayed on the multi-information display does not indicate a malfunction.

Multi-information display driving related data

Press the DISP button to scroll through the trip information contents.

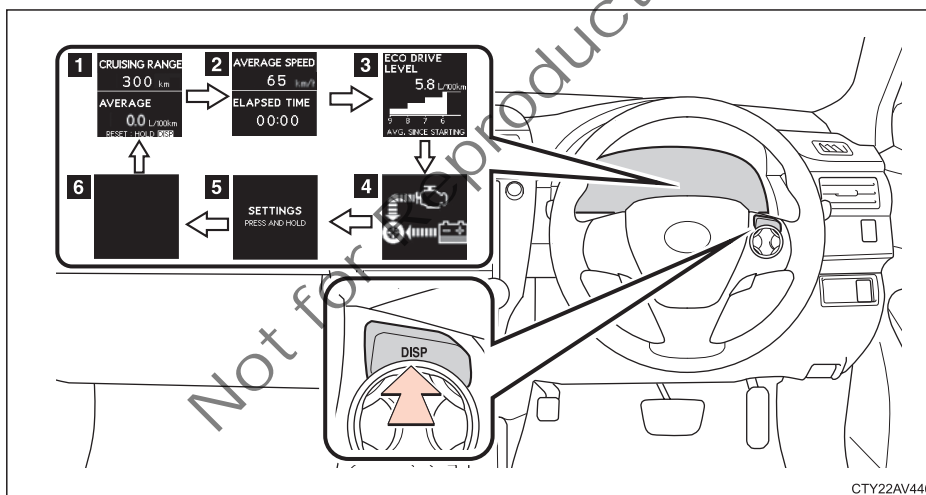

CTY22AV446

Trip information contents		Trip information contents	
1	Cruising range/average fuel consumption	4	Energy monitor
2	Average vehicle speed / elapsed time	5	Customisation
3	Eco drive level	6	– (off)

Trip information

Cruising range / average fuel consumption—

- Cruising range

Displays the estimated maximum distance that can be driven with the quantity of fuel remaining.

- This distance is computed based on your average fuel consumption. As a result, the actual distance that can be driven may differ from that displayed.
- When only a small amount of fuel is added to the tank, the display may not be updated.

When refuelling, press the POWER switch off. If the vehicle is refuelled without pressing the POWER switch off, the display may not be updated.

- Average fuel consumption

Displays the average fuel consumption since the function was reset.

- The function can be reset by pressing the DISP button for longer than 1 second when the average fuel consumption is displayed.

The average fuel consumption meter will also be reset, returning the needle to the 0 position.

- Use the displayed average fuel consumption as a reference.

Average vehicle speed / elapsed time—

Displays the average vehicle speed and elapsed time since the hybrid system was started.

Eco drive level—

Displays the average fuel consumption and eco drive level since the hybrid system was started.

Even if a different screen has been selected for the multi-information display, when the POWER switch is turned off, the eco drive level is displayed. This is not a malfunction.

When the highest eco drive level has been achieved EXCELLENT! is displayed.

Energy monitor—

Displays the status of the hybrid system. Refer to “Energy monitor” on page 8.

Customisation—

Language, Eco Indicator (current fuel consumption gauge) and EV Indicator settings can be changed. Refer below.

Customising vehicle features

It is possible to customise the language, Eco Indicator (current fuel consumption gauge) and EV Indicator settings using the DISP button.

When customising vehicle features, ensure that the vehicle is parked in a safe place with the shift lever in P position and the parking brake set.

Instrument cluster

Language–

1. While the vehicle is stopped, press the DISP button to display the setting screen and then press and hold the DISP button to display the customise mode screen.

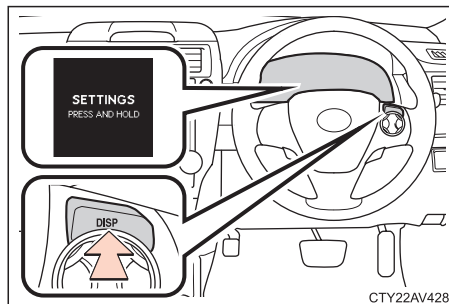

2. Press the DISP button to select the item to be set, then press and hold the DISP button.



3. Press the DISP button to select the desired setting, and then press and hold the DISP button.

To go back to the previous screen or exit the customise mode, press the DISP button to select EXIT, and then press and hold the DISP button.



Eco Indicator

(current fuel consumption gauge)–

While the vehicle is stopped, press the DISP button to display the setting screen and then press and hold the DISP button to display the customise mode screen.

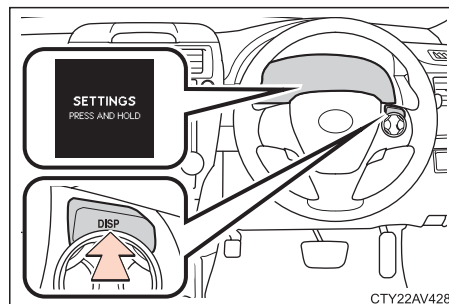

Instrument cluster

1. Press the DISP button to select the item to be set, then press and hold the DISP button.



CTY22AV189

2. Press the DISP button to select the desired setting, and then press and hold the DISP button.

When the ECO INDICATOR is set to OFF, the current fuel consumption gauge will not be displayed.

To go back to the previous screen or exit the customise mode, press the DISP button to select EXIT, and then press and hold the DISP button.

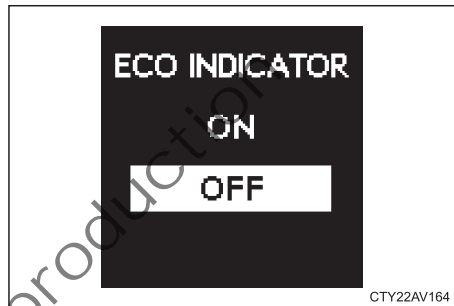

CTY22AV164

EV Indicator –

1. While the vehicle is stopped, press the DISP button to display the setting screen and then press and hold the DISP button to display the customise mode screen.

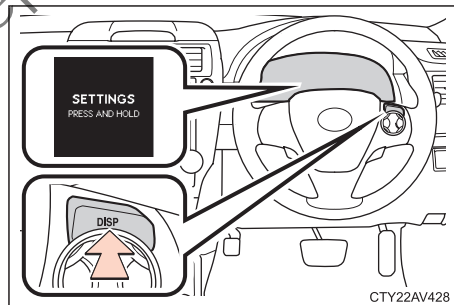

CTY22AV428

2. Press the DISP button to select the item to be set, then press and hold the DISP button.



CTY22AV165

3. Press the DISP button to select the desired setting, and then press and hold the DISP button.

To go back to the previous screen or exit the customise mode, press the DISP button to select EXIT, and then press and hold the DISP button.

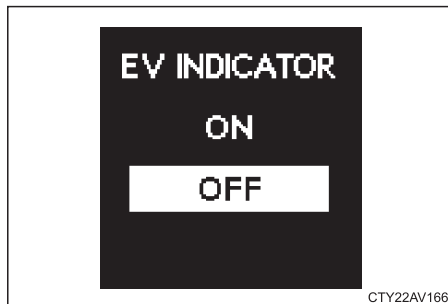

NOTICE

The multi-information display at low temperatures

Allow the interior of the vehicle to warm up before using the liquid crystal information display. At extremely low temperatures, the information display monitor may respond slowly, and display changes may be delayed.

Not for Reproduction

Operating the lights and wipers

Operating the lights and wipers

HEADLIGHT SWITCH

Turning the end of the lever will turn the lights on as follows.

○ Off

AUTO The headlights and parking lights, etc. turn on and off automatically (when the POWER switch is in ON mode).

☰☷ The parking, tail, licence plate and instrument panel lights turn on.

☰☷ The headlights and all the lights listed above turn on.

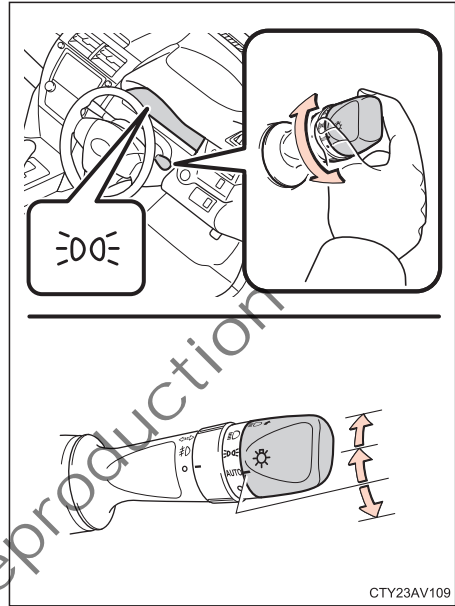

If a headlight, parking light, stop or tail light bulb requires replacing, refer to “Light bulbs” on page 291.

High-Low beams

- For high beams, turn the headlights on and push the lever away from you. To return to low beams, return the lever to the centre position.
- Flashing the high beam headlights: Pull the lever all the way toward you. The high beam headlights turn off when you release the lever. You can flash the high beam headlights with the headlight switch turned to on or off.

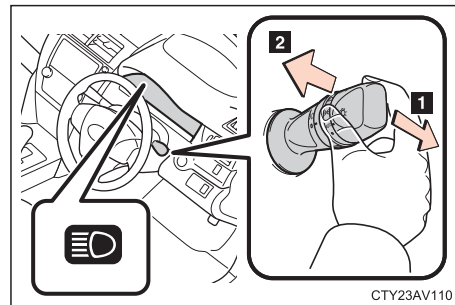

The headlight high beam indicator on the instrument cluster will tell you the high beams are on.

Also refer to “Automatic high beam” on page 118.

Operating the lights and wipers

Headlight control sensor

The automatic light control sensor is located on the top of the instrument panel.

The sensor may not function correctly if an object is placed on the sensor, or anything that blocks the sensor is affixed to the windscreen.

Doing so interferes with the sensor detecting the level of ambient light and may cause the automatic headlight system to malfunction.

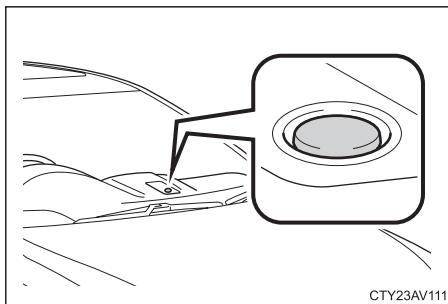

Automatic light cut off system

The lights automatically turn off when the driver's door is opened with the POWER switch pressed to ACCESSORY mode or off.

To turn on the lights again, press the POWER switch to ON mode or turn the headlight switch off and then back to or .

12-volt auxiliary battery-saving function

To prevent the 12-volt auxiliary battery from discharging, if the headlights and / or tail lights are on when the when the POWER switch is pressed off, the 12-volt auxiliary battery saving function will operate and automatically turn off all the lights after approximately 20 minutes.

When the POWER switch is pressed to ON mode, the 12-volt auxiliary battery-saving function will be disabled.

When any of the following are performed, the 12-volt auxiliary battery-saving function is cancelled once and then reactivated. All the lights will turn off automatically 20 minutes after the 12-volt auxiliary battery-saving function has been reactivated:

- When the headlight switch is operated
- When a door is opened or closed.

NOTICE

To prevent the 12-volt auxiliary battery from being discharged, do not leave the lights on for a long period when the hybrid system is not running.

Customisable features that can be modified

For further information refer to "Customisable features" on page 339.

Operating the lights and wipers

AUTOMATIC HIGH BEAM

The Automatic High Beam system uses an in-vehicle camera sensor to assess the brightness of streetlights, the lights of oncoming and preceding vehicles, etc. and automatically turns high beam on or off as required.

Activating the automatic high beam system

1. Press the POWER switch to ON mode.
2. Turn the headlight switch to AUTO position.

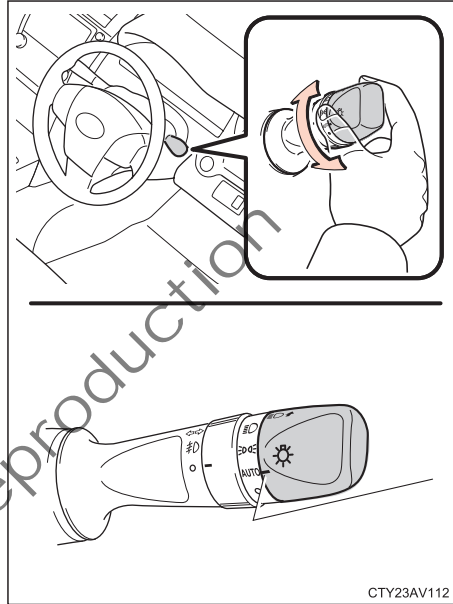

3. Push the lever away from you.

The Automatic High Beam indicator will illuminate when the headlights are turned on automatically to indicate the system is active.

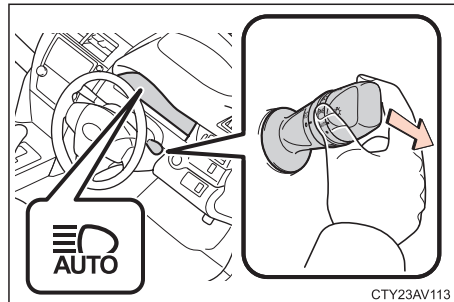

Operating the lights and wipers

Automatic high beam operating conditions

When all the following conditions are fulfilled, high beam will automatically turn on after approximately 1 second.

- The vehicle speed is above approximately 32 km/h.
- The area ahead of the vehicle is dark.
- There are no oncoming or preceding vehicles with headlights or tail lights turned on.

If any of the following conditions are fulfilled, high beam will be automatically turned off.

- Vehicle speed drops below approximately 32 km/h.
- The area ahead of the vehicle is not dark.
- Oncoming or preceding vehicles have headlights or tail lights turned on.

CAUTION

Automatic high beam system limitations

Do not rely on the automatic high beam system. Always drive safely, taking care to observe your surroundings and turning high beam on or off manually if necessary.

Turning the high beam on / off manually

Switching to low beam

- Pull the lever to centre position.

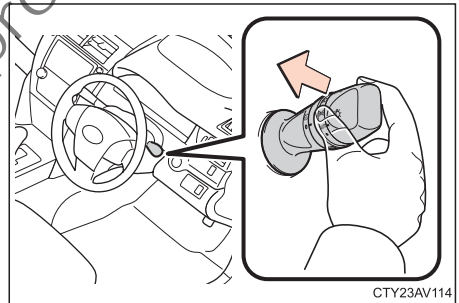

Switching to high beam

- Turn the light switch to  position and push the lever away from you.

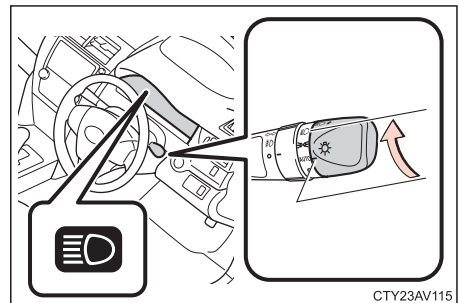

Operating the lights and wipers

INFORMATION

Camera sensor detection information

High beam may not be turned off automatically in the following situations.

- When oncoming vehicles suddenly appear from a curve.
- When the vehicle is cut in front of by another vehicle.

High beam may be turned off if an oncoming vehicle that is using fog lights without using the headlights is detected.

House lights, street lights, red traffic signals and illuminated billboards or signs may cause the high beam to turn off.

The following factors may affect the amount of time taken to turn high beam on or off.

- The brightness of oncoming and preceding vehicles headlights, fog and tail lights.
- Road conditions (wetness, ice, snow, etc.).
- The number of passengers and amount of baggage in the vehicle.

High beam may be turned on or off when unexpected by the driver.

In the situations below, the system may not be able to correctly detect the surrounding brightness levels and may flash or expose nearby pedestrians to the high beam.

Therefore, you should consider turning the high beams on or off manually rather than relying on the automatic high beam system.

- In bad weather (rain, snow, fog, sandstorms, etc.).
- The windscreen is obscured by fog, mist, ice, dirt, etc.
- The windscreen is cracked or damaged.
- The inside rear view mirror or camera sensor is deformed or dirty.
- Surrounding brightness levels are equal to those of the headlights, tail or fog lights.
- Vehicles ahead have headlights that are either switched off, dirty, are changing colour, or are not aimed correctly.
- When driving through an area of intermittently changing brightness and darkness.
- When frequently and repeatedly driving ascending or descending roads, or roads with rough, bumpy or uneven surfaces (stone-paved roads, gravel tracks, etc.).
- When frequently and repeatedly taking curves or driving on a winding road.
- There is a highly reflective object ahead of the vehicle, such as a sign or a mirror.
- The vehicle's headlights are damaged or dirty.
- The vehicle is listing or tilting due to a flat tyre, a trailer being towed, etc.
- The automatic high beam indicator is flashing.
- The headlights are being repeatedly switched between high beam and low beam in an abnormal manner.
- The driver believes the high beam may be causing problems or distress to other drivers or pedestrians nearby.

NOTICE

When using the automatic high beam system

- Do not touch the camera sensor.
- Do not subject the inside rear view mirror or the camera sensor to a strong impact.
- Do not disassemble the camera sensor.
- Do not spill liquid onto the inside rear view mirror or the camera sensor.
- Do not apply window tinting or stickers to the camera sensor or the area of windscreen near the camera sensor.
- Do not place items on the dashboard. There is a possibility the camera sensor will mistake items reflected in the windscreen for streetlights or the headlights of other vehicles, etc.
- Do not install a parking tag or any other accessories near or around the inside rear view mirror and the camera sensor.
- Do not overload the vehicle.
- Do not modify the vehicle.
- Do not replace the windscreen with a non-genuine windscreen. Contact your Toyota dealer should you need to replace your windscreen.

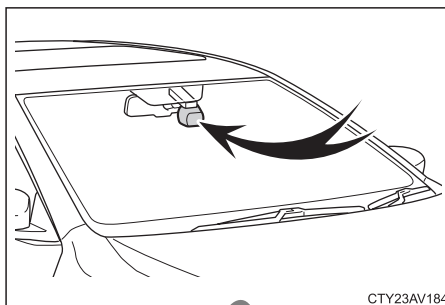

If the automatic high beam indicator illuminates in yellow

This may indicate a malfunction in the automatic high beam system. Contact your Toyota dealer.

Temporary lowering sensor sensitivity

The sensitivity of the sensor can be temporarily lowered by pushing and holding the AUTO button on the inside rear view mirror for 15 to 20 seconds.

The indicator light on the inside rear view mirror will flash to indicate the sensitivity has been lowered.

When the POWER switch is pressed off, the sensitivity will be returned to its normal level.

Customisable features that can be modified

For further information refer to "Customisable features" on page 339.

Operating the lights and wipers

FRONT FOG LIGHTS

The fog lights provide improved visibility in difficult driving conditions such as fog or rain.

1. To turn on the front fog lights, while the parking lights or headlights are turned on, twist the band of the headlight and turn signal switch lever.
2. To turn the front fog lights off, twist the band to the off position.

The front fog light indicator light on the instrument cluster illuminates when the front fog lights are on.

If a fog light bulb requires replacing, refer to "Light bulbs" on page 291.

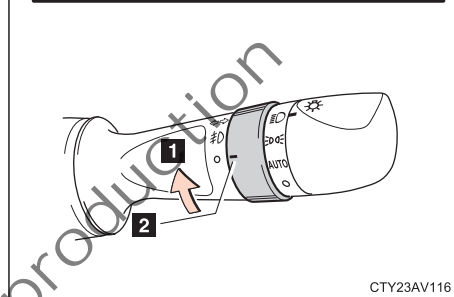
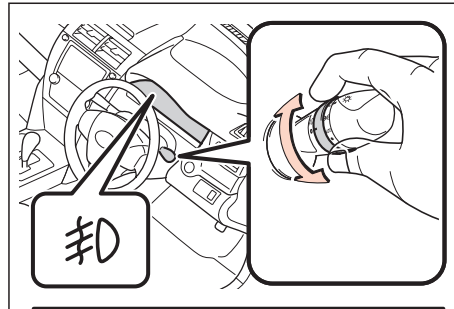

CTY23AV116

WINDSCREEN WIPERS AND WASHERS

Intermittent operation type

The wipers and washers can be operated when the POWER switch is pressed to ON mode.

To turn on the windscreen wipers, move the lever to the desired setting.

1. Intermittent operation.
2. Low speed operation.
3. High speed operation.
4. Single sweep operation.

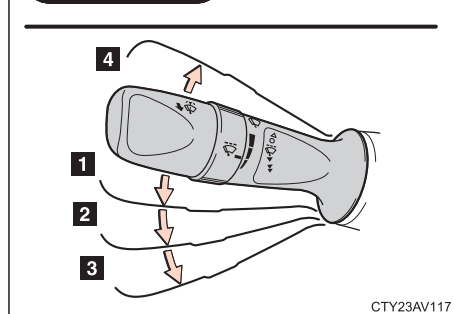
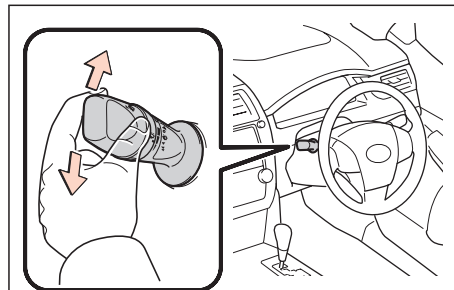

CTY23AV117

Operating the lights and wipers

To adjust the wiper time interval when the wiper lever is in the intermittent position.

1. Twist the band upward to increase the intermittent windscreen wiper frequency.
2. Twist the band downward to decrease the intermittent windscreen wiper frequency.

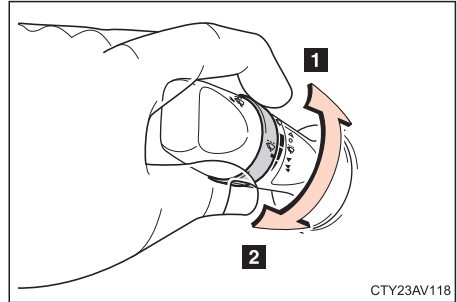

To spray washer fluid.

1. Pull the lever toward you.

The wipers will automatically operate a couple of times after the washer sprays.

- In freezing weather, warm the windscreen with the defroster before using the washer. This will help prevent the washer fluid from freezing on your windscreen, which can block your vision.

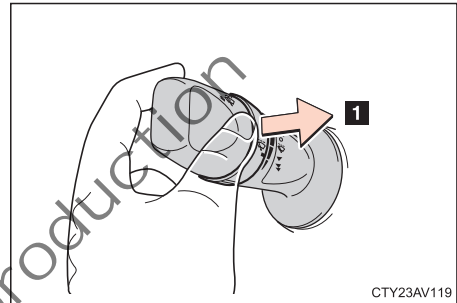

For instructions on adding washer fluid, refer to “Washer fluid” on page 273.

NOTICE

Do not operate the wipers if the windscreen is dry. It may scratch the glass.

If the washer fluid tank is empty, do not operate the washer switch continually as the washer fluid pump may overheat.

If a nozzle becomes blocked, do not try to clear it with a pin or other object. The nozzle will be damaged. Contact your Toyota dealer.

Raindrop detection type

When AUTO position is selected, the wipers will operate automatically when the sensor detects falling rain. The system automatically adjusts wiper timing in accordance with rain volume and vehicle speed.

The wipers and washers can be operated when the POWER switch is pressed to ON mode.

Operating the lights and wipers

To operate the windscreen wipers, move the lever to the desired setting.

1. Rain-sensing wiper operation (AUTO).
2. Low speed wiper operation.
3. High speed wiper operation.
4. Single sweep operation.

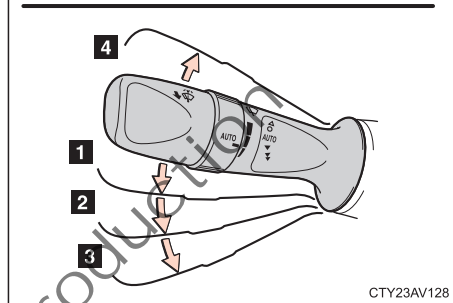
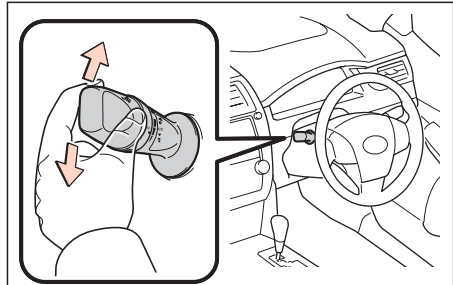

CTY23AV128

When AUTO is selected, the sensor sensitivity can be adjusted as follows by turning the switch ring:

1. Twist the band upward to increase the sensitivity.
2. Twist the band downward to decrease the sensitivity.

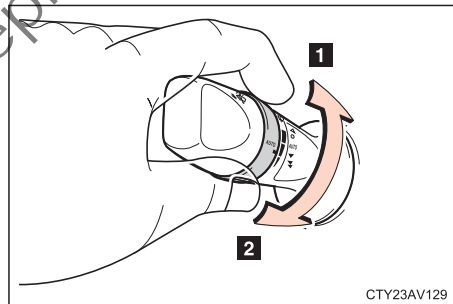

CTY23AV129

To spray washer fluid.

1. Pull the lever toward you.

The wipers will automatically operate a couple of times after the washer sprays. Then, after a short delay, they will operate once more to remove any drips.

- Even when the wipers are not in AUTO mode, wiper operation varies depending on vehicle speed when the washer is being used (delay until drip prevention wiper sweep occurs).

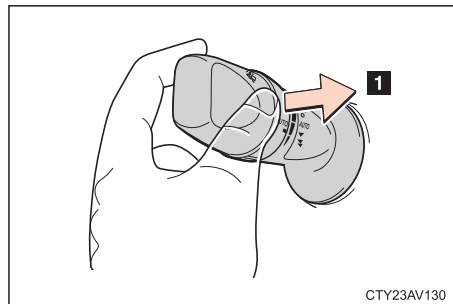

CTY23AV130

Operating the lights and wipers

- In freezing weather, warm the windscreen with the defroster before using the washer. This will help prevent the washer fluid from freezing on your windscreen, which can block your vision.

For instructions on adding washer fluid, refer to “Washer fluid” on page 273.

The wiper frequency is determined by the amount of raindrops detected by the raindrop sensor.

An optical sensor is used which may not operate correctly when sunlight from the rising or setting of the sun intermittently strikes the windscreen, or if bugs, etc. are present on the windscreen.

- If the wiper switch is turned to the AUTO position while the POWER switch is in ON mode, the wiper will operate once to show that AUTO mode is activated.
- If the temperature of the raindrop sensor is 90°C or higher, or -15°C or lower, automatic operation may not occur. In this case, operate the wipers in any mode other than AUTO.

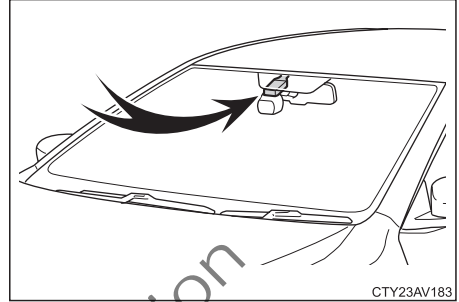

CAUTION

Using the windscreen wipers in AUTO mode

The windscreen wipers may operate unexpectedly if the sensor is touched or the windscreen is subject to vibration while in AUTO mode. Take care that your fingers, etc. do not become caught in the windscreen wipers.

NOTICE

When using an automatic car wash, set the wiper lever to the OFF position.

Do not operate the wipers if the windscreen is dry. It may scratch the glass.

If the washer fluid tank is empty, do not operate the washer switch continually as the washer fluid pump may overheat.

If a nozzle becomes blocked, do not try to clear it with a pin or other object. The nozzle will be damaged. Contact your Toyota dealer.

Using other driving systems

Using other driving systems

CRUISE CONTROL

The cruise control system is designed to maintain a set cruising speed without requiring the driver to operate the accelerator.

Within the limits of the hybrid system's capabilities, cruising speed can be set and maintained above 40 km/h up or down grades. However, changes in vehicle speed may occur on steeper grades.

1. Instrument cluster indicators.
2. Cruise control switch.

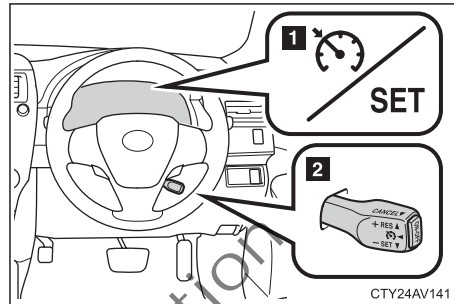

⚠ CAUTION

To help maintain maximum control of your vehicle, do not use the cruise control when driving in heavy or varying traffic, on slippery (rainy, icy or snow-covered) or winding roads, on roads with sharp bends, while towing a trailer or during emergency towing.

Avoid vehicle speed increases when driving downhill. If the vehicle speed is too fast in relation to the cruise control set speed, cancel the cruise control and use engine braking to slow down.

Turning the system on and off

Press the cruise control ON-OFF button to turn the cruise control system on. The cruise control indicator on the instrument cluster will illuminate to indicate the cruise control is operational.

Pressing the ON-OFF button again turns the system off.

When the system is turned off, cruising speed must be reset when the cruise control is turned on again.

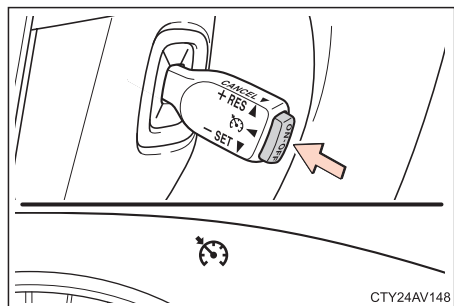

⚠ CAUTION

To avoid accidentally engaging the cruise control, turn the system off when it is not in use. Make sure the cruise control indicator is off.

Using other driving systems

Setting the cruising speed

Set the transmission in D position.

Bring your vehicle to the desired speed above 40 km/h.

Push the lever down in the –SET direction and release it.

- The SET indicator on the instrument cluster will illuminate and the vehicle speed will be set.

You can now take your foot off the accelerator pedal.

If the speed is not satisfactory, operate the lever until the desired speed is obtained.

Fine adjustment:

1. Tap the lever up to increase speed, or
 2. Tap the lever down to decrease speed.
- Each tap changes the speed by 1.6 km/h.

Large adjustment:

1. Hold the lever up to increase speed, or
 2. Hold the lever down to decrease speed.
- Release the lever when the desired speed is obtained.

- If you need acceleration – for example, when overtaking – depress the accelerator pedal enough for the vehicle to exceed the set speed. When you release the accelerator pedal, the vehicle will return to the speed set prior to the acceleration.
- The set speed can also be increased without cancelling the cruise control by accelerating the vehicle to the desired speed and then pushing the lever down (–SET).

Cancelling and resuming the cruise control

Temporary cancellation of the cruise control allows the set cruising speed to be retained in memory while the cruise control system remains on.

1. Pull the lever toward you to cancel the set speed control.
- The set speed is also cancelled when the brakes are applied.
 - The cruise control indicator remains on to indicate the system is still in operation.

2. To resume the set speed control, push the lever up in the +RES direction.

- Resuming is available when the vehicle speed is more than approximately 40 km/h.

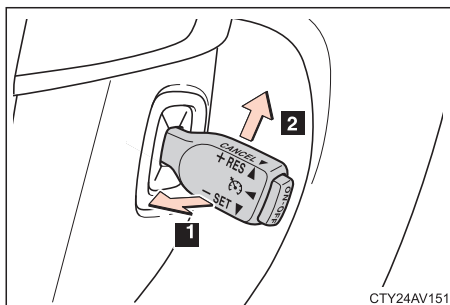
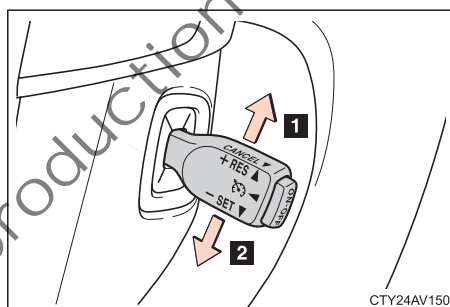
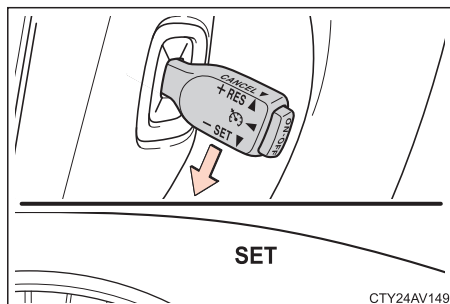

Using other driving systems

INFORMATION

Automatic cruise control cancellation

The cruise control system will stop maintaining the vehicle speed in any of the following situations.

- The actual vehicle speed falls more than approximately 16 km/h below the preset vehicle speed.
At this time, the memorised set speed is not retained.
- The actual vehicle speed is below approximately 40 km/h.
- The VSC system is activated.

If CHECK CRUISE CONTROL SYSTEM is shown on the multi-information display

- Press the ON-OFF button once to deactivate the system, and then press the button again to reactivate the system.
- If the cruise control speed cannot be set or if the cruise control cancels immediately after being activated, there may be a malfunction in the cruise control system. Have the vehicle inspected by your Toyota dealer.

REAR VIEW MONITOR SYSTEM

The rear view monitor system assists the driver by displaying an image of the view behind the vehicle while backing up. The image is displayed in reverse on the audio / navigation screen which allows the image to appear in the same manner as that of the rear view mirror.

To display the rear view image on the screen, place the shift lever in the R position when the POWER is in ON mode.

If you move the shift lever out of the R position, the screen returns to the previous screen. Operating another function of the audio system or navigation system will display another screen.

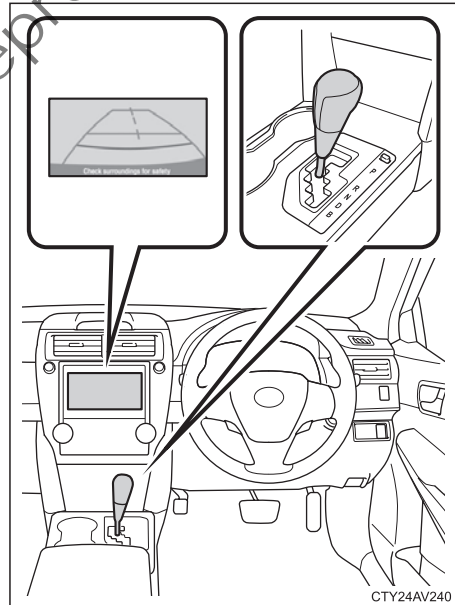

! NOTICE

The rear view monitor system is a supplementary device intended to assist in reversing the vehicle safely. When reversing, ensure to check behind and all around the vehicle visually.

! CAUTION

- Never depend on the rear view monitor system entirely when reversing. Always make sure your intended path is clear. The rear view monitor system is designed to be of assistance when reversing only and does not replace the need to visually check the area around the vehicle when reversing to avoid injury or any other damage.
- Use caution, just as you would when reversing any vehicle.
- The guide lines are ancillary lines and do not change even if the steering wheel is turned.
- Never reverse while looking only at the screen. The image on the screen is different from actual conditions. Depicted distances between objects and flat surfaces will differ from actual distance. If you reverse while looking only at the screen, you may hit a vehicle, a person or an object. When reversing, always check behind and all around the vehicle visually and with mirrors before proceeding. The image on the screen may be inaccurate in the following ways:
 - The distances depicted between objects and flat surfaces will differ from actual distances
 - If the temperature changes rapidly, such as when hot water is poured on the vehicle in cold weather, the system may not operate normally
 - If the camera lens becomes dirty, it cannot transmit a clear image. If water droplets, snow, or mud adhere to the lens, rinse with water and wipe with a soft cloth. If the lens is extremely dirty, wash it with a mild cleanser and rinse
 - When the outside temperature is low or the system is cold, the displayed image may become faint or dark, and moving images will be distorted, or not entirely visible
 - If the back of the vehicle is damaged, the position and mounting angle of the camera may change. Have the camera's position and mounting angle checked at your Toyota dealer
 - If the boot lid is not completely closed
 - As the camera has a water proof construction, do not detach, disassemble or modify it. This may cause incorrect operation
 - Do not allow organic solvent, car wax, window cleaner or glass coat to adhere to the camera. If this happens, wipe off as soon as possible

When replacing the tyres, please consult your Toyota dealer. If you replace the tyres, the area displayed on the screen may change.

Using other driving systems

Rear view monitor guide lines

Guide lines are displayed on the monitor.

1. Vehicle width extension guide lines.
These lines indicate the estimated vehicle width extension.
2. Distance guide line.
This line indicates a position on the ground about 1 m behind the rear bumper of your vehicle.
3. Distance guide line (red).
This line indicates a position on the ground about 0.5 m behind the rear bumper of your vehicle.
4. Vehicle centre guide lines.
These lines indicate the estimated vehicle centre on the ground.

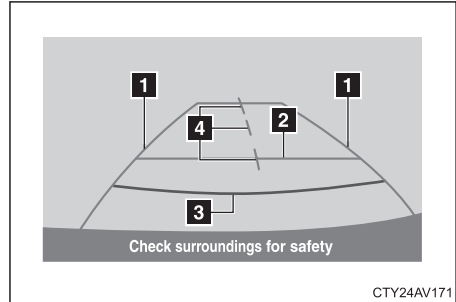

Displayed area

The area detected by the camera is limited.

Objects which are close to either corner of the bumper or are under the bumper may not be seen on the screen.

The area displayed on the screen may vary according to vehicle orientation or road conditions.

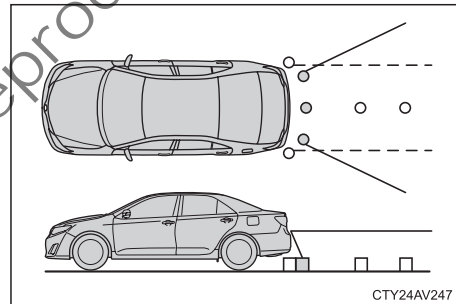

The camera uses a special lens.

The distance of the image that appears on the screen differs from the actual distance.

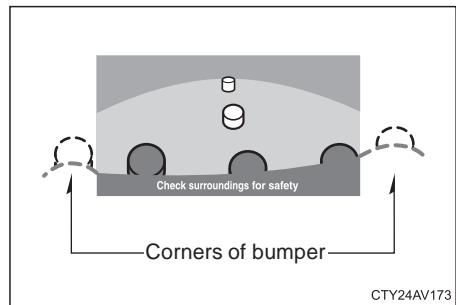

Using other driving systems

Driving precautions

When the grade behind the vehicle slopes up sharply, objects appear to be farther away than they actually are.

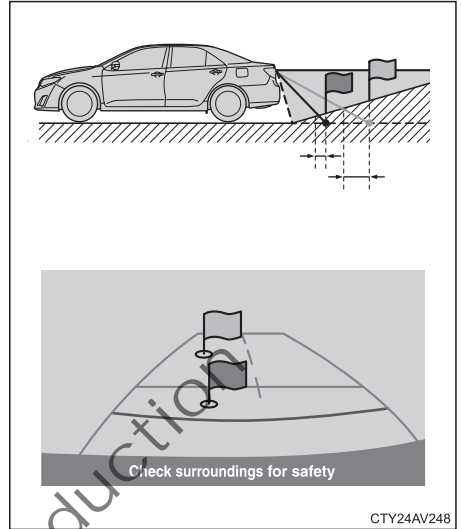

When the grade behind the vehicle slopes down sharply, objects appear to be closer than they actually are.

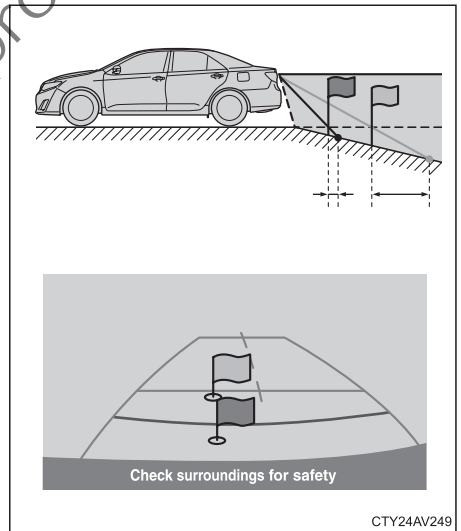

Using other driving systems

The distance between three-dimensional objects (such as another vehicle) and flat surfaces (such as the road) appears different on the screen as follows.

In reality, A and C are the same distance from the vehicle, while B is farther away.

However, on the screen, the situation appears to be A is closer than B which appears closer than C. On the screen, it appears that a truck is parked approximately 1 m away.

In reality if you back up to point A, you will hit the truck.

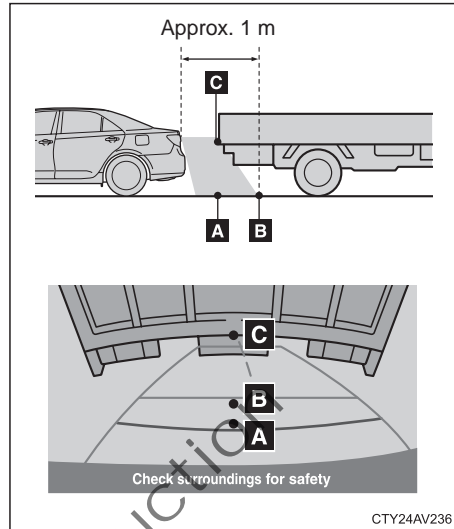

Rear view monitor system camera

The rear view monitor system camera is located on the boot lid as shown in the illustration.

In the following cases, it may become difficult to see the images on the screen, even when the system is functioning.

- In the dark, such as at night.
- When the temperature near the lens is high or low.
- When water droplets are adhering to the camera, or when humidity is high, such as when it rains.
- When foreign matter, such as snow or mud is adhering to the camera.
- When the sun or the beam of headlights is shining directly into the camera lens.
- When the camera has scratches or dirt on it.

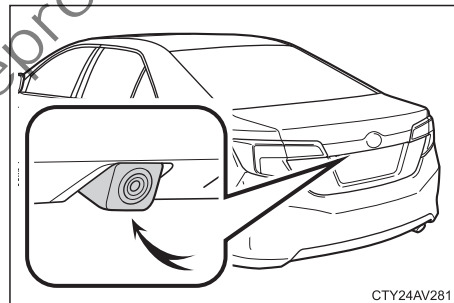

Flicker effect

When the camera is used under fluorescent lights, sodium lights, mercury lights, etc., the lights and the illuminated areas may appear to flicker.

Using other driving systems

TOYOTA PARKING ASSIST-SENSOR

The Toyota parking assist-sensor is a warning system to assist the driver when backing up the vehicle.

It uses two ultrasonic sensors installed near the centre of the rear bumper, which check the approximate distance to an obstacle and inform you by beeping sounds.

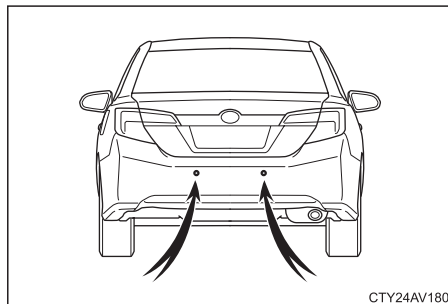

CTY24AV180

⚠ CAUTION

The Toyota parking assist-sensor is designed to be of assistance only when parking and does not replace the need to visually check the area around the vehicle when parking to avoid injury or other danger.

Parking assist-sensor switch

With the POWER switch in ON mode, push the parking assist-sensor switch.

The indicator light on the switch comes on, indicating the parking assist-sensor is on.

Pushing the switch again will turn the parking assist-sensor off.

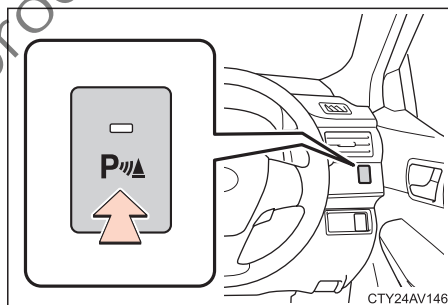

CTY24AV146

Detection range of sensor

When the parking assist-sensor is on and the shift lever is in R position, the sensor will detect objects behind the vehicle and sound a buzzer as follows.

Approximate distance to obstacle	Beeps
60 cm to 150 cm	Slow intermittent
45 cm to 60 cm	Medium intermittent
35 cm to 45 cm	Fast intermittent
Within 35 cm	Continuous

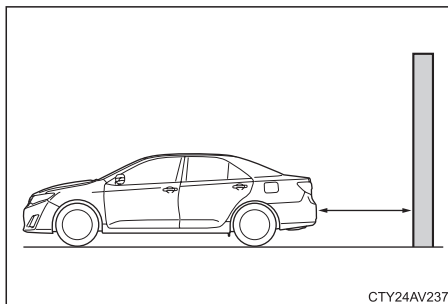

CTY24AV237

Using other driving systems

Approximately 150 cm.

The diagram shows the detection range of the sensors. Note the sensors cannot detect obstacles that are extremely close to the vehicle.

The range of the sensors may change depending on the shape of the object, etc.

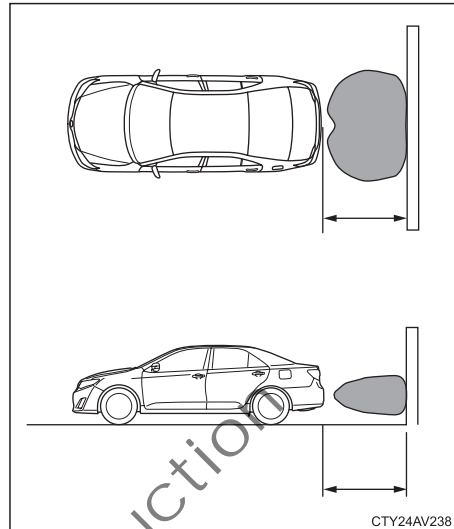

⚠ CAUTION

The Toyota parking assist-sensor may not detect the following:

- Thin objects such as wire or rope
- Sound wave absorbing objects such as cotton or snow
- Objects with a sharp edge
- Tall objects with the upper part projected
- Shorter objects

Always visually check the area around the vehicle when parking.

⚠ CAUTION

To avoid an accident or injury, observe the following instructions, and then drive slowly using the brakes while visually confirming a safe distance around your vehicle.

- The sensor detection range is limited around the bumper. Always visually confirm safety outside the sensor detection.
- It might take time for the sensors to detect obstacles.
- Depending on the shape of the obstacle, indicators or beeps may not warn you correctly, and the detection range may also be shortened.
- It might be difficult to hear beeps due to the volume of audio or air flow noise of the air conditioning.

 **CAUTION**

The Toyota parking assist-sensor may not work correctly in the following cases:

- When the bumper is damaged. Contact your Toyota dealer
- When the part near the sensors is subjected to a strong impact
- When an accessory is installed within the sensor detection range
- When snowflakes or mud gets on the sensors.
(If removed, the parking assist-sensor will work correctly)
- When water is splashed from a high pressure car wash or there is steam on the sensors
- When a sensor is covered with your hand
- When the vehicle is tilted
- In extreme hot or cold weather (In extreme cold weather, the error display appears and the parking assist-sensor becomes inoperative)
- When driving on bumpy roads, slopes, gravelled roads or grass
- When devices issuing ultrasonic waves are operated around your vehicle, such as the horns from other vehicles, motorcycle engines, the air braking sound from heavy vehicles, etc
- When another vehicle equipped with ultrasonic sensors gets close to your vehicle
- When heavy rain or water is splashed over the vehicle.
(Drive carefully as the braking distance may be affected)
- When a radio antenna is mounted on your vehicle
- When you are driving towards a tall curb stone or curb stone at right angles
- The detection range for an object such as a traffic sign may be shortened
- An object just under the bumper may not be detected. Although an object lower than the location of sensors is once detected, the detection might be stopped when your vehicle gets closer to the object
- When an obstacle is very close to the sensors

Using other driving systems

BLIND SPOT MONITOR (BSM)

The blind spot monitor is a system that assists the driver in making the decision to change lanes.

The system uses radar sensors to detect vehicles that are travelling in an adjacent lane within the area not reflected in the outside rear view mirror (the blind spot), and advises the driver of the vehicle's existence via an outside rear view mirror indicator.

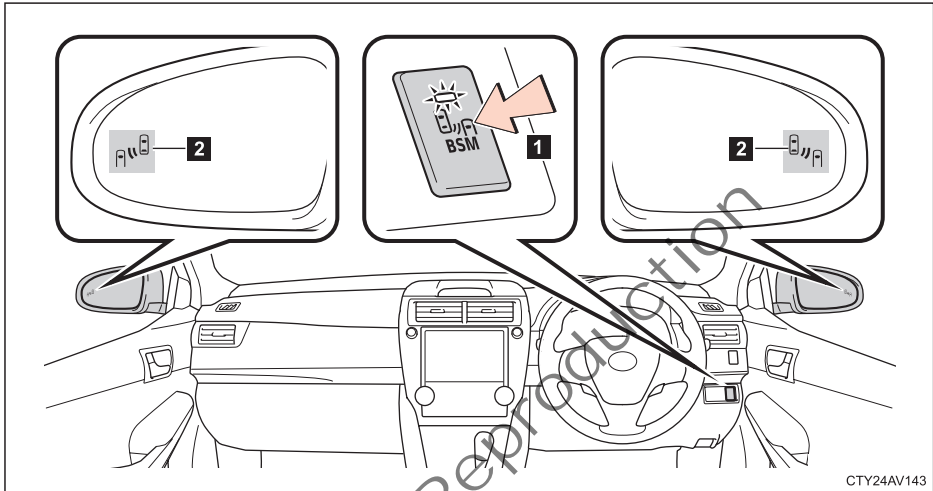

CTY24AV143

1. **BSM main switch:**
Pressing the switch turns the system on or off. When the switch is set to on, the switch's indicator illuminates.
2. **Outside rear view mirror indicator:**
When a vehicle is detected in the blind spot, the outside rear view mirror indicator on that side illuminates.
If the turn signal lever is operated when a vehicle is in the blind spot, the outside rear view mirror indicator flashes.

INFORMATION

The blind spot monitor is operational when:

- The BSM main switch is set to on and vehicle speed is greater than about 40 km/h.

The blind spot monitor will detect a vehicle when:

- A vehicle in an adjacent lane overtakes your vehicle
- Another vehicle enters the vehicle's detection area when it changes lanes.

Towing

When towing, Toyota recommends that the Blind Spot Monitor System is turned OFF to prevent unnecessary warning activation.

Blind spot monitor detection areas

The range of the blind spot area where other vehicles can be detected in extends to:

1. Approximately 3.5 metres from the side of your vehicle.
The first 0.5 metre from the side of your vehicle is not in the detection area.
2. Approximately 3 metres from your rear bumper.
3. Approximately 1 metre forward of your rear bumper.

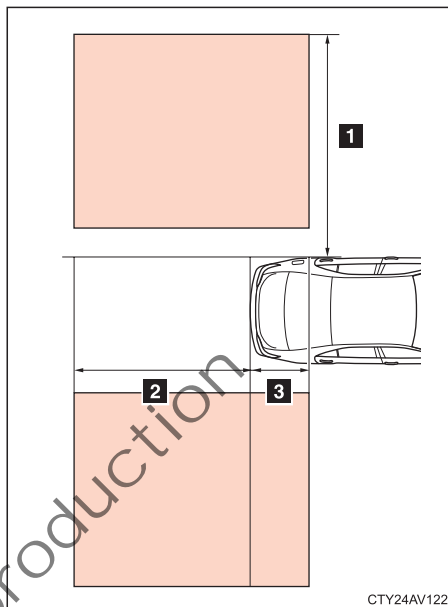

⚠ CAUTION

Cautions regarding the use of the system

The driver is solely responsible for safe driving. Always drive safely, taking care to observe your surroundings.

Use the blind spot monitor in conjunction with the driver's own visual confirmation of safety. The blind spot monitor is a supplementary system which alerts the driver that a vehicle is present in the blind spot. The system cannot judge if it is safe to change lanes, therefore over-reliance could cause an accident resulting in death or serious injury. According to conditions, the system may not function correctly.

For information on conditions under which the blind spot monitor may not function correctly refer below.

Conditions under which the blind spot monitor will not detect a vehicle

The blind spot monitor is not designed to detect the following types of vehicles and/or objects:

- Vehicles travelling from the opposite direction
- Small motorcycles, bicycles, pedestrians, etc.*
- Guardrails, walls, signs, parked vehicles and similar stationary objects*
- Following vehicles that are in the same lane*
- Vehicles driving two lanes across from your vehicle*

*: Depending on conditions, detection of a vehicle and/or object may occur

Using other driving systems

Conditions under which the blind spot monitor may not function correctly

The blind spot monitor may not detect vehicles correctly in the following conditions:

- During bad weather such as heavy rain, fog or snow, etc.
- When ice or mud, etc. is attached to the rear bumper
- When driving on a road surface that is wet due to rain or standing water, etc.
- When there is a significant difference in speed between your vehicle and the vehicle that enters the detection area
- When a vehicle is in the detection area from a stop and remains in the detection area as your vehicle accelerates
- When driving up or down consecutive steep inclines, such as hills or a dip in the road, etc.
- When multiple vehicles approach with only a small gap between each vehicle
- When vehicle lanes are wide and the vehicle in the next lane is too far away from your vehicle
- When the vehicle that enters the detection area is travelling at about the same speed as your vehicle
- When there is a significant difference in height between your vehicle and the vehicle that enters the detection area
- Directly after the BSM switch is set to on
- When towing a trailer
- When items such as a bicycle carrier are installed on the rear of the vehicle

Instances of the blind spot monitor detecting a vehicle and/or object unnecessarily may increase under the following conditions:

- When there is only a short distance between your vehicle and a guardrail or wall, etc.
- When there is only a short distance between your vehicle and a following vehicle
- When vehicle lanes are narrow and a vehicle driving two lanes across from your vehicle enters the detection area

The outside rear view mirror indicator's visibility

When under strong sunlight, the outside rear view mirror indicator may be difficult to see.

When there is a malfunction in the system

If a system malfunction is detected due to any of the following reasons, warning messages will be displayed (refer to "Warning messages" on page 100):

- There is a malfunction with the sensors
- The sensors have become dirty
- The outside temperature is extremely high or low
- The sensor voltage has become abnormal

⚠ NOTICE**Handling the radar sensor**

One blind spot monitor is installed inside the left-hand and right-hand side of the vehicle rear bumper respectively. Observe the following to ensure the blind spot monitor can function correctly.

- Keep the sensor and its surrounding area on the bumper clean at all times.
- Do not subject the sensor or surrounding area on the bumper to a strong impact. If the sensor moves even slightly off position, the system may malfunction and vehicles that enter the detection area may not be detected. If the sensor or surrounding area is subject to a strong impact, always have the area inspected by your Toyota dealer.
- Do not disassemble the sensor.
- Do not attach accessories or stickers to the sensor or surrounding area on the bumper bar.
- Do not modify the sensor or surrounding area on the bumper bar.
- Do not paint the sensor or surrounding area on the bumper.

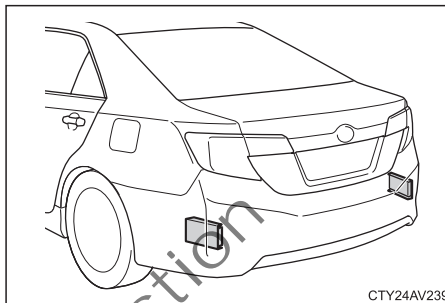

Not for Reproduction

Using other driving systems

DRIVING ASSIST SYSTEMS

To help enhance driving safety and performance, the following driving assist systems operate automatically in response to various situations while the vehicle is being driven.

Be aware, however, these systems should be used as a supplementary aid and the driver should not rely on these systems in place of the driver's own judgement and observations.

- **Anti-lock Brake System (ABS)**
Helps to prevent wheel lock when the brakes are applied suddenly, or if the brakes are applied while driving on a slippery road surface.
- **Brake Assist**
Generates an increased level of braking force after the brake pedal is depressed when the system detects a panic stop situation.
- **Vehicle Stability Control (VSC)**
Helps the driver to control skidding when swerving suddenly or turning on slippery road surfaces.
- **Traction Control (TRC)**
Helps to maintain drive power and prevent the drive wheels from spinning when starting the vehicle or accelerating on slippery roads.
- **Hill-start assist control**
Helps to prevent the vehicle from rolling backwards when starting on an incline or slippery slope. Refer to "Hill-start assist control" on page 142.
- **Electric Power Steering (EPS)**
Employs an electric motor to reduce the amount of effort needed to turn the steering wheel.

When the TRC / VSC / ABS systems are operating

If the vehicle is in danger of slipping or if any of the drive wheels spins, the slip indicator flashes to indicate the TRC / VSC / ABS systems are operating.

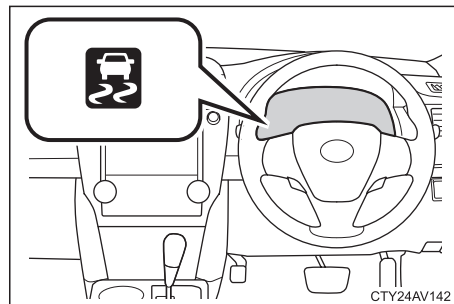

The slip indicator along with an ABS warning light and EPS warning light illuminate for a few seconds when the POWER switch button is pressed to ON mode.

If the indicator and warning lights do not illuminate when the hybrid system is turned on, or if they remain illuminated and do not go off, contact your Toyota dealer.

INFORMATION

Sounds and vibrations caused by the ABS, brake assist, VSC and TRC systems

A sound may be heard from the engine compartment when the hybrid system is started or just after the vehicle begins to move. This sound does not indicate that a malfunction has occurred in any of these systems.

Any of the following conditions may occur when the above systems are operating. None of these indicate that a malfunction has occurred.

- Vibrations may be felt through the vehicle body and steering.
- A motor sound may be heard after the vehicle comes to a stop.
- The brake pedal may pulsate slightly after the ABS is activated.
- The brake pedal may move down slightly after the ABS is activated.

EPS operation sound.

- When the steering wheel is operated, a motor sound (whirring sound) may be heard. This does not indicate a malfunction.

Reduced effectiveness of the EPS system.

- The effectiveness of the EPS system is reduced to prevent the system from overheating when there is frequent steering input over an extended period of time. The steering wheel may feel heavy as a result.

Should this occur, refrain from excessive steering input or stop the vehicle and turn the hybrid system off. The EPS system should return to normal within 10 minutes.

If it does not, contact your Toyota dealer.

CAUTION

The ABS does not operate effectively when

Tyres with inadequate gripping ability are used (such as excessively worn tyres on a snow covered road).

The vehicle hydroplanes while driving at high speed on wet or slick roads.

Stopping distance when the ABS is operating may exceed that of normal conditions

The ABS is not designed to shorten the vehicle's stopping distance. Always maintain a safe distance from the vehicle in front of you in the following situations:

- When driving on dirt, gravel or snow-covered roads
- When driving with tyre chains
- When driving over bumps in the road
- When driving over roads with potholes or uneven surfaces

Using other driving systems

⚠ CAUTION

TRC may not operate effectively when

Directional control and power may not be achievable while driving on slippery road surfaces, even if the TRC system is operating.

Do not drive the vehicle in conditions where stability and power may be lost.

When the VSC is activated

The slip indicator flashes. Always drive carefully. Reckless driving may cause an accident. Exercise particular care when the indicator flashes.

Replacing tyres

Make sure that all tyres are of the specified size, brand, tread pattern and total load capacity. In addition, make sure the tyres are inflated to the recommended tyre inflation pressure level.

The ABS, TRC and VSC systems will not function correctly if different tyres are installed on the vehicle.

Contact your Toyota dealer for further information when replacing tyres or wheels.

Handling of tyres and the suspension

Using tyres with any kind of problem or modifying the suspension will affect the driving assist systems and may cause the system to malfunction.

Hill-start assist control

Hill-start assist control helps to prevent the vehicle from rolling backwards when starting on an incline or slippery slope.

To engage hill-start assist control, further depress the brake pedal when the vehicle is stopped completely.

A buzzer will sound once to indicate the system is activated. The slip indicator will also start flashing.

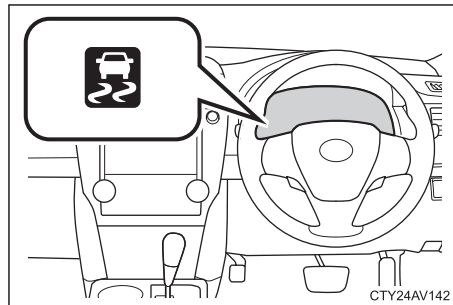

⚠ CAUTION

Do not overly rely on hill-start assist control. Hill-start assist control may not operate effectively on extremely steep inclines or roads covered in ice.

Unlike the parking brake, hill-start assist control is not intended to hold the vehicle stationary for an extended period of time. Do not attempt to use hill-start assist control to hold the vehicle on an incline for an extended period of time, as doing so may lead to an accident.

Using other driving systems

Hill-start assist control can be operated when—

- The shift lever is in a position other than P.
- The parking brake is not applied.
- The accelerator pedal is not depressed.

Hill-start assist control—

- While hill-start assist control is operating, the brakes remain automatically applied after the driver releases the brake pedal. The stop lights and the high mounted stoplight turn on.
- Hill-start assist control operates for about 2 seconds after the brake pedal is released.
- If the slip indicator does not flash and the buzzer does not sound when the brake pedal is further depressed, slightly reduce the pressure on the brake pedal (do not allow the vehicle to roll backward) and then firmly depress it again. If the system still does not operate, check if the operating conditions explained above have been met.

Hill-start assist control buzzer—

- When hill-start assist control is activated, the buzzer will sound once.
- In the following situations, hill-start assist control will be cancelled and the buzzer will sound twice.
 - No attempt is made to drive the vehicle within approximately 2 seconds of releasing the brake pedal.
 - The shift lever is moved to P position.
 - The parking brake is applied.
 - The brake pedal is depressed again.
 - The brake pedal has been depressed for more than approximately 3 minutes.

If the slip indicator comes on—

- It may indicate a malfunction in the system. Contact your Toyota dealer.

Driving Information

RUNNING-IN PERIOD

To extend the life of your vehicle the following precautions are recommended:

- For the first 300 km:
 - Avoid sudden or hard stops
- For the first 800 km:
 - Do not tow a trailer
- For the first 1000 km:
 - Avoid full throttle acceleration when starting and driving
 - Avoid over-revving the engine
 - Do not drive for a long time at any single speed, either fast or slow

Drum-in-disc type parking brake system

Your vehicle has a drum-in-disc type parking brake system. This type of brake system needs bedding-down of the brake shoes periodically or whenever the parking brake shoes and/or drum are replaced. Have your Toyota dealer perform the bedding down operation.

PRE-TRIP SAFETY CHECK

It is a good idea to do a safety check before starting out on a trip. A few minutes of checking can help ensure safe and pleasant driving. Just a basic familiarity with your vehicle is required and a careful eye!

Items to check include, but are not limited to:

- Tyre condition and pressure (including the spare wheel)
- Fluid levels. If the vehicle has been parked for a while check for fluid leaking underneath the vehicle. (Water dripping from the air conditioner after use is normal)
- All lights operate normally
- No indicators or warning lights remain illuminated once the vehicle has been started
- Any other items or noises that appear abnormal

If you would like, your Toyota dealer will be pleased to make this check for you at a nominal cost.

INFORMATION WHEN DRIVING IN VARIOUS CONDITIONS

CAUTION

When starting the vehicle

- Always keep your foot on the brake pedal while stopped with the hybrid system running. This prevents the vehicle from creeping.

When driving the vehicle

- Do not drive if you are unfamiliar with the location of the brake and accelerator pedals to avoid depressing the wrong pedal.
 - Accidentally depressing the accelerator pedal instead of the brake pedal will result in sudden acceleration that may lead to an accident that could result in death or serious injury.
 - When reversing, you may twist your body around, leading to difficulty operating the pedals.
 - Maintain the correct driving posture even when moving the vehicle only slightly. This allows you to depress the brake and accelerator pedals correctly.
 - Depress the brake pedal using your right foot. Depressing the brake pedal using your left foot may delay response in an emergency, resulting in an accident.
- The driver should pay extra attention to pedestrians when the vehicle is powered only by the electric motor. Because there is no engine noise, the pedestrians may misjudge the vehicle's movement.
- Do not drive the vehicle over, or stop the vehicle near, flammable materials such as long grass, etc. The exhaust system and exhaust gases can be extremely hot. These hot parts may cause a fire if there is any flammable material nearby.
- Do not let the vehicle roll backward while the shift lever is in a driving position, or roll forward while the shift lever is in R position. Doing so may cause the engine to stall or lead to poor brake and steering performance, resulting in an accident or damage to the vehicle.
- If the smell of exhaust is noticed inside the vehicle, open the windows and check the boot lid is closed. Large amounts of exhaust in the vehicle can cause driver drowsiness and an accident, resulting in death or a serious health hazard. Have the vehicle inspected by your Toyota dealer immediately.
- Do not move the shift lever to P position while the vehicle is moving. Doing so can damage the transmission and may result in a loss of vehicle control.
- Do not move the shift lever to R position while the vehicle is moving forward. Doing so can damage the transmission and may result in a loss of vehicle control.
- Do not move the shift lever to D position while the vehicle is moving backward. Doing so can damage the transmission and may result in a loss of vehicle control.
- Moving the shift lever to N position while the vehicle is moving will disengage the hybrid system. Engine braking is not available with the hybrid system disengaged.

Driving Information

CAUTION

- During normal driving, do not turn off the hybrid system. Turning the hybrid system off while driving will not cause loss of steering or braking control, but the power assist to these systems will be lost, making it more difficult to steer and brake. Pull over and stop the vehicle as soon as it is safe to do so. In the event of an emergency, such as if it becomes impossible to stop the vehicle in the normal way, refer to “If your vehicle has to be stopped in an emergency” on page 328.
- Use engine braking (downshift) to maintain a safe speed when driving down a steep hill, refer to “Hybrid transmission” on page 86.
Using the brakes continuously may cause the brakes to overheat and lose effectiveness.
- Do not adjust the positions of the steering wheel, the seat, or the inside or outside rear view mirrors while driving. Doing so may result in a loss of vehicle control that can cause an accident, resulting in death or serious injury.
- Always check that all passenger’s arms, heads or other parts of their body are not outside the vehicle, as this may result in death or serious injury.

When driving on slippery road surfaces

- Sudden braking, acceleration and steering may cause tyre slippage and reduce your ability to control the vehicle, resulting in an accident.
- Sudden acceleration, engine braking due to shift changing, or changes in engine speed may cause the vehicle to skid, resulting in an accident.
- After driving through a puddle, lightly depress the brake pedal to make sure the brakes are functioning properly. Wet brake pads may prevent the brakes from functioning properly. If the brakes on only one side are wet and not functioning properly, steering control may be affected, resulting in an accident.

When shifting the shift lever

- Be careful not to shift the shift lever with the accelerator pedal depressed. Shifting the shift lever to a gear other than P or N may lead to unexpected rapid acceleration of the vehicle that may cause an accident and result in death or serious injury.

If you hear a squealing or scraping noise (brake pad wear indicators)

- Have the brake pads checked and replaced by your Toyota dealer as soon as possible. Rotor damage may result if the pads are not replaced when needed. It is dangerous to drive the vehicle when the wear limits of the brake pads and/or those of the brake discs are exceeded.

When the vehicle is stopped

- Do not over-rev the engine. If the vehicle is in any gear other than P or N, the vehicle may accelerate suddenly and unexpectedly, causing an accident.
- Do not leave the vehicle with the hybrid system on for a long time. If such a situation cannot be avoided, park the vehicle in an open space and check that exhaust fumes do not enter the vehicle interior.

 **CAUTION**

- In order to prevent accidents due to the vehicle rolling away, always keep depressing the brake pedal while the READY indicator is on, and apply the parking brake as necessary.
- If the vehicle is stopped on an incline, in order to prevent accidents caused by the vehicle rolling forward or backward, always depress the brake pedal and securely apply the parking brake as needed.
- Avoid revving or racing the engine. Running the engine at high speed while the vehicle is stopped may cause the exhaust system to overheat, which could result in a fire if combustible material is nearby.

When the vehicle is parked

- Do not leave glasses, cigarette lighters, spray cans, or soft drink cans in the vehicle when it is in the sun. Doing so may result in the following:
 - Gas may leak from a cigarette lighter or spray can, and may lead to a fire
 - The temperature inside the vehicle may cause the plastic lenses and plastic material of glasses to deform or crack
 - Soft drink cans may fracture, causing the contents to spray over the interior of the vehicle, and may also cause a short circuit in the vehicle's electrical components
- Do not leave cigarette lighters in the vehicle. If a cigarette lighter is in a place such as the glove box or on the floor, it may be lit accidentally when luggage is loaded or the seat is adjusted, causing a fire.
- Do not attach adhesive discs to the windscreen or windows. Do not place containers such as air fresheners on the instrument panel or dashboard. Adhesive discs or containers may act as lenses, causing a fire in the vehicle.
- Do not leave a door or window open if the curved glass is coated with a metallised film such as a silver-coloured one. Reflected sunlight may cause the glass to act as a lens, causing a fire.
- Always apply the parking brake, shift the shift lever to P position, stop the hybrid system and lock the vehicle.
Do not leave the vehicle unattended while the hybrid system is running.
- Do not touch the exhaust pipes while the hybrid system is operating or immediately after turning the hybrid system off. Doing so may cause burns.
- Do not leave the hybrid system operating in an area with snow build-up, or where it is snowing. If snowbanks build up around the vehicle while the hybrid system is operating, exhaust gases may collect and enter the vehicle. This may lead to death or a serious health hazard.

Driving Information

CAUTION

Exhaust gases

Exhaust gases include harmful carbon monoxide (CO), which is colourless and odourless. Inhaling exhaust gases may lead to death or a serious health hazard.

- If the vehicle is in a poorly ventilated area, stop the hybrid system. In a closed area, such as a garage, exhaust gases may collect and enter the vehicle. This may lead to death or a serious health hazard.
- The exhaust system should be checked occasionally. If there is a hole or crack caused by corrosion, damage to a joint or abnormal exhaust noise, have the vehicle inspected and repaired by your Toyota dealer. Failure to do so may allow exhaust gases to enter the vehicle, resulting in death or a serious health hazard.

When taking a nap in the vehicle

- Always turn the hybrid system off. Otherwise, if you accidentally move the shift lever or depress the accelerator pedal, this could cause an accident or fire due to the hybrid system overheating. Additionally, if the vehicle is parked in a poorly ventilated area, exhaust gases may collect and enter the vehicle, leading to death or a serious health hazard.

When braking

- When the brakes are wet, drive more cautiously. Braking distance increases when the brakes are wet, and this may cause one side of the vehicle to brake differently than the other side. Also, the parking brake may not securely hold the vehicle.
- If the electronically controlled brake system does not operate, do not follow other vehicles closely and avoid hills or sharp turns that require braking.
In this case, braking is still possible, but the brake pedal should be depressed more firmly than usual. Also, the braking distance will increase.
- The brake system consists of 2 individual hydraulic systems; if one of the systems fails, the others will still operate. In this case, the brake pedal should be depressed more firmly than usual and the braking distance will increase. If this happens, do not continue to drive the vehicle. If the brake system warning light (red indicator) comes on together with the buzzer sound while driving, immediately stop the vehicle in a safe place and contact your Toyota dealer.

NOTICE

When driving the vehicle

- Do not depress the accelerator and brake pedals at the same time during driving, as this may restrain driving torque.
- Do not use the accelerator pedal or depress the accelerator and brake pedals at the same time to hold the vehicle on a hill.

 NOTICE

Engine speed while driving

In the following conditions, the engine speed may become high while driving. This is due to automatic up-shifting control or down-shifting implementation to meet driving conditions. It does not indicate sudden acceleration.

- The vehicle is judged to be driving uphill or downhill
- When the accelerator pedal is released

When parking the vehicle

- Always move the shift lever to P position. Failure to do so may cause the vehicle to move or the vehicle may accelerate suddenly if the accelerator pedal is accidentally depressed.

Avoiding damage to vehicle parts

- Do not turn the steering wheel fully in either direction and hold it there for an extended period of time. Doing so may damage the power steering motor.
- When driving over bumps in the road, drive as slowly as possible to avoid damaging the wheels or underside of the vehicle, etc.

If you get a flat tyre while driving

- A flat or damaged tyre may cause the following situations. Hold the steering wheel firmly and gradually depress the brake pedal to slow down the vehicle.
 - It may be difficult to control your vehicle
 - The vehicle will make abnormal sounds or vibrations
 - The vehicle will lean abnormally
- For information on how to change a flat tyre refer to "If you have a flat tyre" on page 312.

When encountering flooded roads

- Do not drive on a road that has flooded after heavy rain, etc. Doing so may cause the following serious damage to the vehicle:
 - Engine stalling
 - A short circuit in electrical components
 - Engine damage caused by water immersion
- In the event that you drive on a flooded road and the vehicle is flooded, have your Toyota dealer check the following:
 - Brake function
 - Changes in quantity and quality of engine oil, and transaxle fluid, etc.
 - Lubricant condition of the bearings and suspension joints (where possible) and the function of all joints and bearings, etc.

Driving Information

WINTER DRIVING TIPS

Perform the necessary preparations and inspections before driving the vehicle in winter. Always drive the vehicle in a manner appropriate to the prevailing weather conditions.

Driving in the rain

Drive carefully when it is raining as visibility will be reduced and the windows may become fogged-up.

Drive carefully when it starts to rain, because the road surface will be especially slippery. Refrain from high speeds when driving on an expressway in the rain, because there may be a layer of water between the tyres and the road surface that could cause the vehicle to hydro-plane, preventing the steering and brakes from operating properly.

Pre-winter preparations

Use the following fluids that are appropriate to the prevailing outside temperatures:

- Engine oil
- Engine coolant
- Washer fluid

Have your Toyota dealer check the engine coolant and inspect the level and specific gravity of battery electrolyte.

If required, have the vehicle fitted with four snow tyres, or purchase a set of tyre chains for the front tyres.

- Ensure that all tyres are the same size and brand, and the chains match the size of the tyres.

Before driving the vehicle

Perform the following according to the driving conditions.

- Do not try to forcibly open a window or move a wiper that is frozen. Pour warm water over the frozen area to melt the ice.
- Wipe away the water immediately to prevent it from freezing.
- To ensure correct operation of the climate control system fan, remove any snow that has accumulated on the air inlet vents in front of the windscreen.
- Remove any ice that has accumulated on the vehicle chassis.
- Periodically check for and remove any excess ice or snow that may have accumulated in the wheel-well or on the brakes.

When driving the vehicle

Accelerate the vehicle slowly and drive at a reduced speed suitable to the road conditions.

When parking the vehicle

Where there is a chance the parking brake may freeze up, park the vehicle and move the shift lever to P position without setting the parking brake. If the parking brake freezes it may not release. If necessary, block the wheels to prevent inadvertent sliding or creeping.

INSTALLING SNOW TYRES AND CHAINS

When to use snow tyres or chains

Snow tyres or chains are recommended when driving on snow or ice.

On wet or dry roads, conventional tyres provide better traction than snow tyres.

Snow tyre selection

If you need snow tyres, select tyres of the same size, construction and load capacity as the originally installed tyres.

Do not use tyres other than those mentioned above. Do not install studded tyres without first checking local regulations for possible restrictions.

! CAUTION

Do not use snow tyres other than the manufacturer's recommended size, as this may cause dangerous handling characteristics resulting in loss of control. Otherwise, an accident may occur resulting in death or serious injuries.

Snow tyre installation

Installing snow tyres on the front wheels only can lead to an excessive difference in road grip capability between the front and rear tyres, which could cause loss of vehicle control.

When storing removed tyres, you should store them in a cool dry place.

Mark the direction of rotation and ensure to install them in the same direction when replacing.

! CAUTION

- Snow tyres should be installed on all wheels of the vehicle.
- Do not drive with the snow tyres incorrectly inflated.
- Observe permissible maximum speed for your snow tyres and the legal speed limit (whichever is lower).

Tyre chain selection

Use the tyre chains of the correct type and size.

1. Diameter of side chain3.0 mm
2. Width of side chain10.0 mm
3. Length of side chain30.0 mm
4. Diameter of cross chain4.0 mm
5. Width of cross chain14.0 mm
6. Length of cross chain25.0 mm

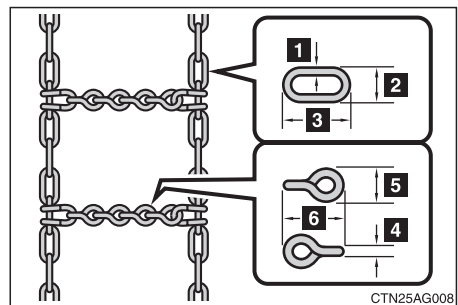

Driving Information

NOTICE

If the wrong combination of tyre and chain is used, the chains could damage the vehicle body and/or not achieve their intended outcome.

Chain installation

Install the chains on the front tyres as tightly as possible. Do not use tyre chains on the rear tyres. Retighten chains after driving 0.5 – 1.0 km.

When installing chains on your tyres, carefully follow the instructions of the chain manufacturer.

If wheel covers are used, they will be scratched by the chain band, so remove the covers before putting on the chains.

CAUTION

Do not use tyre chains on the rear tyres.

When using tyre chains:

- Do not exceed 50 km/h or the chain manufacturer's recommended speed limit, whichever is lower
- Drive carefully avoiding bumps, holes, and sharp turns, which may cause the vehicle to bounce.
- Avoid sharp turns or locked-wheel braking as use of chains may adversely affect vehicle handling
- Slow down before entering curves to avoid losing control of the vehicle, otherwise an accident may occur

TRAILER TOWING

Your vehicle is designed primarily as a passenger-carrying vehicle. Towing a trailer will have an adverse effect on handling, performance, braking, durability and driving economy (fuel consumption, etc.).

Your safety and satisfaction depend on the correct use of equipment and cautious driving habits.

NOTICE

For your safety and the safety of others, you must not overload your vehicle or trailer.

Toyota warranties do not apply to damage or malfunction caused by towing a trailer for commercial purposes.

Ask your local Toyota dealer for further details before towing, as there are additional legal requirements in some countries.

Weight limits

Before towing make sure that all of the following are within the specified limits:

- Total trailer weight
- Gross vehicle weight
- Gross axle weight
- Vertical tow ball load

The total trailer weight and vertical tow ball load can be measured with platform scales which are located at such places as a public weighbridge.

! CAUTION

The total trailer weight (trailer weight plus its cargo load) must not exceed 300 kg.

Trailer tow bar assemblies have different weight capacities established by the tow bar manufacturer. The operator must determine the maximum weight rating of the particular tow bar assembly, even though the vehicle may be physically capable of towing a greater weight, and never exceed the maximum weight rating specified for the trailer tow bar.

Exceeding the maximum weight rating set by the trailer tow bar manufacturer can cause vehicle damage or an accident resulting in serious personal injuries.

The gross vehicle weight must not exceed 2100 kg

The gross vehicle weight is the sum of weights of the:

- Unloaded vehicle
- Driver
- Passengers
- Luggage
- Tow bar
- Trailer vertical tow ball load
- Any special equipment installed on your vehicle.

The load on either the front or the rear axle resulting from distribution of the gross vehicle weight on both axles must not exceed:

Front: 1040 kg

Rear: 1060 kg

INFORMATION**Blind spot monitor**

When towing, Toyota recommends that the Blind Spot Monitor System is turned OFF to prevent unnecessary warning activation.

Driving Information

! CAUTION

The trailer cargo load should be distributed so the vertical tow ball load is 9 to 11% of the total trailer weight, not exceeding 30 kg.

- Vertical tow ball load / total trailer weight x 100 = 9 to 11%

Never load the trailer with more weight in the back than in the front. About 60% of the trailer load should be in the front half of the trailer and the remaining 40% in the rear.

1. Total trailer weight.
2. Vertical tow ball load.

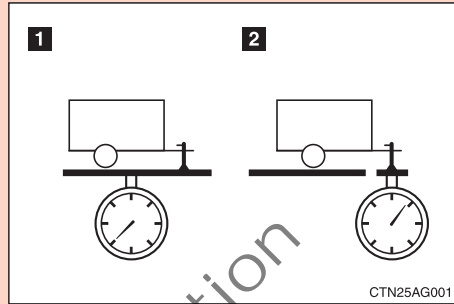

Tow bars

Use only a tow bar which is recommended by the tow bar manufacturer and conforms to the total trailer weight requirement.

Follow the directions supplied by the tow bar manufacturer, and bolt the tow bar securely to the vehicle. Lubricate the tow ball with a light coat of grease.

If removing the tow bar assembly, seal any mounting holes in the vehicle body to prevent entry of pollutants such as exhaust fumes, dirt or water.

Brakes and safety chains

Toyota recommends trailers with brakes conform to applicable Federal and State regulations.

Safety chains must always be used between the towing vehicle and the trailer.

Leave sufficient slack in the chains for turns.

The chains should cross under the trailer coupling to prevent the trailer coupling from dropping to the ground in case it becomes damaged or the trailer separates from the vehicle.

For correct safety chains procedures, follow the tow bar or trailer manufacturer's recommendations.

! CAUTION

- Never tap into your vehicle's hydraulic system as it would lower its braking effectiveness.
- Never tow a trailer without using safety chains securely attached to both the trailer and the vehicle.

Tyres

Ensure your vehicle's tyres are correctly inflated. Refer to "Checking the tyre inflation pressure" on page 274.

The trailer tyres should be inflated to the pressure recommended by the trailer manufacturer in respect to the total trailer weight.

Trailer lights

Trailer lights must comply with federal and state regulations. See your Toyota dealer for the correct type of wiring and relays for your trailer.

Check for correct operation of the turn signals and stop lights each time you attach the trailer. Direct splicing may damage your vehicle's electrical system and cause a malfunction of your lights.

Running-in schedule

Toyota recommends that you do not tow a trailer with a new vehicle or a vehicle with any new powertrain component (engine, transmission, differential, wheel bearing, etc.) for the first 800 km of driving.

Maintenance

If you tow a trailer, your vehicle will require more frequent maintenance due to the additional load. For this information, please refer to the scheduled maintenance information in the Warranty and Service Book.

Retighten all fixing bolts of the tow ball and tow bar after approximately 1000 km of trailer driving.

Pre-towing safety check

Check your vehicle remains level when a loaded or unloaded trailer is attached. Do not drive if the vehicle has an abnormal nose-up or nose-down condition, and check for incorrect vertical tow ball load, overload, load distribution of the vehicle or trailer, worn suspension or other possible causes.

Make sure the trailer cargo is securely loaded so that it cannot shift.

Check your rear view mirrors conform to any applicable federal and state regulations. If not, install the rear view mirrors required for the towing purposes.

Trailer towing tips

CAUTION

- When towing a trailer, your vehicle will handle differently than when not towing.
 - The three main causes of vehicle trailer accidents are driver error, excessive speed and incorrect trailer loading.
-
- Before starting out, check operation of the lights and all vehicle-trailer connections. After driving a short distance, stop and recheck the lights and connections. Before actually towing a trailer, practice turning, stopping and backing with a trailer in an area away from traffic until you learn the feel of the vehicle.

Driving Information

- Backing with a trailer is difficult and requires practice. Grip the bottom of the steering wheel and move your hand to the left to move the trailer to the left. Move your hand to the right to move the trailer to the right. (This procedure is generally opposite to that when backing without a trailer.)

Also, just turn the steering wheel a little at a time, avoiding sharp or prolonged turning. Have someone guide you when backing to reduce the risk of an accident.

- Because stopping distance may be increased, vehicle-to-vehicle distance should be increased when towing a trailer. For each 10 km/h of speed, allow at least one vehicle and trailer length between you and the vehicle ahead. Avoid sudden braking as you may skid, resulting in jack-knifing and loss of control. This is especially true on wet or slippery surfaces.
- Avoid jerky starts or sudden acceleration.
- Avoid jerky steering and sharp turns. The trailer could hit your vehicle in a tight turn. Slow down before making a turn to avoid the necessity of sudden braking.
- Remember that when making a turn, the trailer wheels will be closer than the vehicle wheels to the inside of the turn. Therefore, compensate for this by making a larger than normal turning radius with your vehicle.
- Crosswinds and rough roads will adversely affect the handling of your vehicle and trailer, causing sway. Pay attention to the rear from time to time to prepare yourself for being passed by large trucks or buses, which may cause your vehicle and trailer to sway. If swaying happens, firmly grip the steering wheel and reduce speed immediately but gradually. Never increase speed. If it is necessary to reduce speed, brake slowly. Steer straight ahead following the road. If you make no extreme correction with the steering or brakes, the vehicle and trailer will stabilise.
- Be careful when passing other vehicles. Passing requires considerable distance. After passing a vehicle, do not forget the length of your trailer and ensure you have plenty of room before changing lanes.
- Because of the added load of the trailer, your vehicle's engine may overheat on hot days (at temperatures over 30°C) when going up a long or steep grade with a trailer. If the engine coolant temperature gauge indicates overheating, immediately turn off the air conditioning (if in use), pull off the road and stop in a safe spot. Refer to "If your vehicle overheats" on page 325.
- Always place wheel chocks under both the vehicle and trailer wheels when parking. Apply the parking brake firmly and put the transmission in P position. Avoid parking on a slope with a trailer, but if it cannot be avoided, do so only after performing the following.
 1. Apply the brakes and hold.
 2. Have someone place wheel chocks under both the vehicle and trailer wheels.
 3. When the wheel blocks are in place, release your brakes slowly until the blocks absorb the load.
 4. Apply the parking brake firmly.
 5. Shift into P position and turn off the hybrid system.

- When restarting out after parking on a slope:
 1. With the transmission in P position, start the hybrid system. Ensure to keep the brake pedal depressed.
 2. Shift into gear.
 3. Release the parking brake and foot brake, and slowly pull or back away from the wheel chocks. Stop and apply your brakes.
 4. Have someone retrieve the wheel chocks.

CAUTION

Observe the legal maximum speeds for trailer towing.

Slow down and downshift before descending steep or long downhill grades. Do not make sudden downshifts.

Avoid holding the brake pedal down too long or too frequently. This could cause the brakes to overheat and result in reduced braking efficiency.

CARGO AND LUGGAGE

When stowing cargo or luggage in the vehicle, observe the following.

- Put cargo or luggage in the boot when at all possible. Ensure all items are secured in place.
- Be careful to keep the vehicle balanced. Locating the weight as far forward as possible helps maintain balance.
- For better fuel economy, do not carry unnecessary weight.

CAUTION

Never allow anyone to ride in the enlarged boot (when the rear seat is folded down). It is not designed for passengers. They should ride in their seats with their seatbelts correctly fastened. Otherwise, they are much more likely to suffer death or serious injury in the event of sudden braking or a collision.

To prevent cargo or luggage from sliding forward during braking, do not stack anything in the enlarged boot higher than the seatback. Keep cargo or luggage low, as close to the floor as possible.

Do not place anything on the parcel shelf behind the rear seatback. Such items may be thrown about and possibly injure people in the vehicle during sudden braking or an accident.

Driving Information

CAUTION

Do not drive with objects left on top of the instrument panel. They may interfere with the driver's field of view. Or they may move during sharp vehicle acceleration or turning, and impair the driver's control of the vehicle. In an accident they may injure the vehicle occupants.

Items that must not be carried in the boot

The following items may cause a fire if loaded in the boot:

- Receptacles containing petrol
- Aerosol cans

CAUTION

Storage precautions

Observe the following precautions. Failure to do so may result in death or serious injury.

- Stow cargo and luggage in the boot whenever possible.
- Fold-down type rear seat: To prevent cargo and luggage from sliding forward during braking, do not stack anything in the enlarged boot. Keep cargo and luggage low, as close to the floor as possible.
- Fold-down type rear seat: When you fold down the rear seats, long items should not be placed directly behind the front seats.
- Fold-down type rear seat: Never allow anyone to ride in the enlarged boot. It is not designed for passengers. They should ride in their seats with their seatbelts properly fastened. Otherwise, they are much more likely to suffer death or serious bodily injury, in the event of sudden braking, sudden swerving or an accident.
- Do not place cargo or luggage in or on the following locations as the item may get under the clutch, brake or accelerator pedal and prevent the pedals from being depressed properly, block the driver's vision, or hit the driver or passengers, causing an accident:
 - At the feet of the driver
 - On the front passenger or rear seats (when stacking items)
 - On the package tray
 - On the instrument panel
 - On the dashboard
- Secure all items in the occupant compartment, as they may shift and injure someone during sudden braking, sudden swerving or an accident.
- Load and distribution
 - Do not overload your vehicle.
 - Do not apply loads unevenly.
 - Improper loading may cause deterioration of steering or braking control which may cause death or serious injury.

INTERIOR FEATURES

Using the air conditioning system and defogger . . .	161
AUTOMATIC AIR CONDITIONING SYSTEM	161
FRONT, SIDE AND REAR VENTS	168
REAR WINDOW DEFOGGER	169
Touch-screen audio system	170
QUICK REFERENCE	170
SETUP MENU	171
VEHICLE INFORMATION	174
AUDIO SYSTEM	176
USING THE RADIO	179
USING THE CD PLAYER	181
PLAYING AN AUDIO CD AND MP3 / WMA DISCS	181
LISTENING TO AN iPod®	189
LISTENING TO A USB MEMORY	194
USING THE AUX PORT	200
LISTENING TO BLUETOOTH® AUDIO	201
OPTIMAL USE OF THE AUDIO SYSTEM	208
USING THE STEERING WHEEL AUDIO SWITCHES	209
HANDS-FREE SYSTEM (FOR MOBILE PHONES)	211
USING THE BLUETOOTH® PHONE	215
SETTING THE HANDS-FREE SYSTEM	224
BLUETOOTH® SETTINGS	233
Using the interior lights	238
INTERIOR LIGHTS OVERVIEW	238
INTERIOR LIGHTS	238
PERSONAL LIGHTS	239
ILLUMINATED ENTRY SYSTEM	240
Using the storage features	241
STORAGE FEATURES OVERVIEW	241
GLOVE BOX	242
AUXILIARY BOXES	242
REAR CONSOLE BOX	243
CUP HOLDERS	244
BOTTLE HOLDERS	245
GROCERY BAG HOOKS	246

continued overleaf

INTERIOR FEATURES (CONT)

Other interior features	247
CLOCK	247
POWER OUTLETS	247
SUN VISORS	248
VANITY MIRRORS	249
REAR ELECTRIC SUNSHADE	249
FLOOR MAT	250
ASSIST GRIPS	251
COAT HOOKS	252

Not for Reproduction

Using the air conditioning system and defogger

Using the air conditioning system and defogger

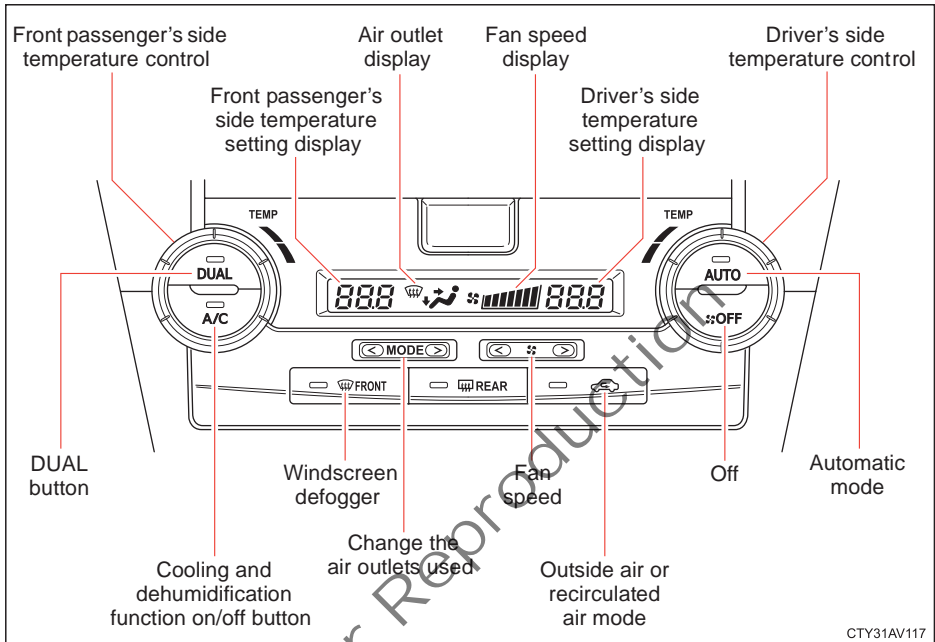

AUTOMATIC AIR CONDITIONING SYSTEM





Using the automatic air conditioning system

1. Press .

The air conditioning system begins to operate. Air outlets and fan speed are automatically adjusted according to the temperature setting.

2. Turn  clockwise to increase the temperature and turn  counterclockwise to decrease the temperature.

When  is pressed (the  indicator is on) or the passenger's side temperature control dial is turned, the temperature for the driver and passenger seats can be adjusted separately.

NOTE: Air outlets and fan speed are automatically adjusted according to the temperature setting and the ambient conditions. The fan may stop briefly until warm or cool air is ready to flow when  is pressed.

Adjusting the settings manually



1. To turn on the air conditioning, press . The A/C button indicator will come on. To turn the air conditioning off, press the button again.

Using the air conditioning system and defogger

- To adjust the fan speed, press [**>**] on  to increase the fan speed and [**<**] to decrease the fan speed.

Press  to turn the fan off.

- To adjust the temperature setting, turn  clockwise to increase the temperature and turn  counterclockwise to decrease the temperature.

When  is pressed (the  indicator is on) or the passenger's side temperature control dial is turned, the temperature for the driver and passenger seats can be adjusted separately.

- To change the air outlets, press [**<**] or [**>**] on .

The air outlets used are switched each time either side of the button is pressed.

Air outlets and air flow

Panel– Air flows to the upper body.

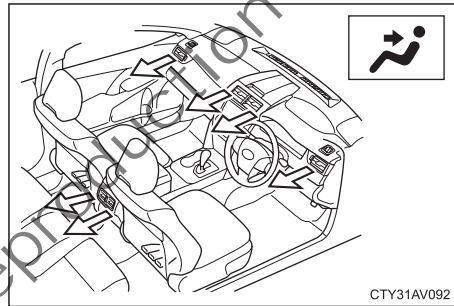

Bi-level– Air flows to the upper body and feet.

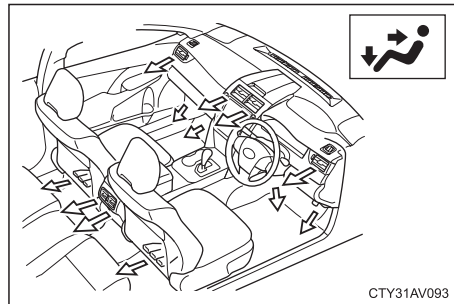

Floor– Air flows to the feet.

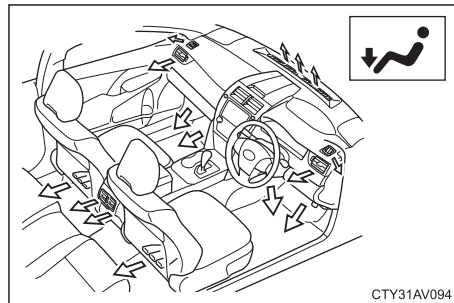

Using the air conditioning system and defogger

Windscreen / Floor– Air flows to the feet and the windscreen defogger operates.

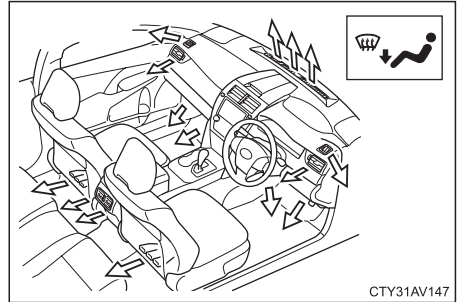

Defogging the windscreen

1. Press .

The dehumidification function operates and the fan speed increases.

Set the outside / recirculated air mode button to the outside air mode if the recirculated air mode is used (it may switch automatically).

To defog the windscreen and the side windows quickly, increase the air flow and temperature settings.

To return to the previous mode, press  again when the windscreen is defogged.

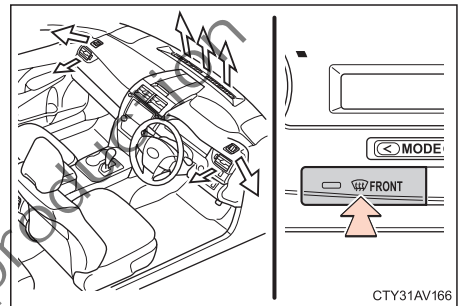

Switching between outside air and recirculated air modes

Press .



The mode switches between outside air mode (the indicator is off) and recirculated air mode (the indicator is on) each time the button is pressed.

NOTE: Recirculated air mode or outside air mode may automatically switch depending on the temperature setting, outside temperature, pressure, engine coolant temperature or the inside temperature.

Operating tips

- To cool off your Toyota after it has been parked in the hot sun, drive with the windows open for a few minutes. This vents the hot air, allowing the air conditioning to cool the interior more quickly.
- Make sure the air intake grilles in front of the windscreen are not blocked (by leaves or snow, for example).
- On humid days, do not blow cold air on the windscreen. The windscreen could fog up because of the difference in air temperature on the inside and outside of the windscreen.

Using the air conditioning system and defogger

- The windows will easily fog up when the humidity in the vehicle is high. Turning  on will dehumidify the air from the outlets and defog the windscreen effectively. If you turn  off, the windows may fog up more easily. The windows may fog up more easily if the recirculated air mode is used.
- Keep the area under the front seats clear to allow air to circulate throughout the vehicle.
- On cold days, set the fan speed to high for a minute to help clear the intake ducts of snow or moisture. This can reduce the amount of fogging on the windows.
- When driving on dusty roads, close all windows. If dust thrown up by the vehicle is still drawn into the vehicle after closing the windows, it is recommended the air intake selector be set to FRESH and the fan speed selector to any setting except OFF.
- If following another vehicle on a dusty road, or driving in windy and dusty conditions, it is recommended the air intake selector be temporarily set to RECIRCULATE, which will close off the outside passage and prevent outside air and dust from entering the vehicle interior.
- When the outside temperature falls to nearly 0°C the dehumidification function may not operate even when  is pressed.

Air conditioning odours –

- During use, various odours from inside and outside the vehicle may enter into and accumulate in the air conditioning system. This may then cause odour to be emitted from the vents.
- To reduce potential odours from occurring:
 - It is recommended that the air conditioning system be set to outside air mode prior to turning the vehicle off.
 - The start timing of the blower may be delayed for a short period of time immediately after the air conditioning system is started in automatic mode.

CAUTION

To prevent the windscreen from fogging up do not use  with the air conditioning on in extremely humid weather.

The difference in temperature between the outside air and the windscreen can cause the outer surface of the windscreen to fog up, blocking your vision.

NOTICE

To prevent 12-volt auxiliary battery discharge do not leave the air conditioning system on longer than necessary when the hybrid system is stopped.

Using the air conditioning system and defogger

Heating

For best results, set controls as follows:

for automatic operation–

Press in the AUTO button

Temperature – To the desired temperature

Air intake – FRESH (outside air)

Air conditioning – OFF

for manual operation–

Fan speed – To the desired fan speed

Temperature – Towards WARM

Air intake – FRESH (outside air)

Air flow – FLOOR

Air conditioning – OFF

- For quick heating, select recirculated air for a few minutes. To keep the windows from fogging, select fresh after the vehicle interior has been warmed.
- Press the A/C button on for dehumidified heating.
- Choose floor / windscreen air flow to heat the vehicle interior while defrosting or defogging the windscreen.

Air conditioning

For best results, set controls as follows:

for automatic operation–

Press in the AUTO button

Temperature – To the desired temperature

Air intake – FRESH (outside air)

Air conditioning – ON

for manual operation–

Fan speed – To the desired fan speed

Temperature – Towards COLD

Air intake – FRESH (outside air)

Air flow – PANEL

Air conditioning – ON

For quick cooling, select recirculated air for a few minutes.

Using the air conditioning system and defogger

Ventilation

For best results, set controls as follows:

for automatic operation–

<i>Press in the AUTO button</i>	
<i>Temperature</i>	– Towards low temperature
<i>Air intake</i>	– FRESH (outside air)
<i>Air conditioning</i>	– OFF

for manual operation–

<i>Fan speed</i>	– To the desired fan speed
<i>Temperature</i>	– Towards COLD
<i>Air intake</i>	– FRESH (outside air)
<i>Air flow</i>	– PANEL
<i>Air conditioning</i>	– OFF

Defogging and defrosting the inside of the windscreen

For best results, set controls as follows:

for automatic operation–

<i>Temperature</i>	– Towards high temperature to heat; Low temperature to cool
<i>Air intake</i>	– FRESH (outside air)
<i>Air flow</i>	– WINDSCREEN

for manual operation–

<i>Fan speed</i>	– To the desired fan speed
<i>Temperature</i>	– Towards high temperature to heat; Low temperature to cool
<i>Air intake</i>	– FRESH (outside air)
<i>Air flow</i>	– WINDSCREEN

- Pressing the windscreen button turns on the defroster linked air conditioning. At this time, the A/C button indicator comes on regardless of whether or not the A/C button is pressed in. This is to clean up the front view more quickly.
- To turn off the air conditioning alone, press the A/C button once again.
- When the A/C button is not pressed in, pressing another air flow button turns off the air conditioning.
- On humid days, do not blow cold air on the windscreen. The difference between the outside and inside temperatures could make the fogging worse.

Using the air conditioning system and defogger

Defogging and defrosting the outside of the windscreen

For best results, set controls as follows:

for automatic operation–

<i>Temperature</i>	– Towards high temperature
<i>Air intake</i>	– FRESH (outside air)
<i>Air flow</i>	– WINDSCREEN

for manual operation–

<i>Fan speed</i>	– To the desired fan speed
<i>Temperature</i>	– Towards high temperature
<i>Air intake</i>	– FRESH (outside air)
<i>Air flow</i>	– WINDSCREEN

- Pressing the windscreen button turns on the defroster linked air conditioning. At this time, the A/C button indicator comes on regardless of whether or not the A/C button is pressed in. This is to clean up the front view more quickly.
- To turn off the air conditioning alone, press the A/C button once again.
- When the A/C button is not pressed in, pressing another air flow button turns off the air conditioning.
- To heat the vehicle interior while defrosting the windscreen, choose floor / windscreen air flow.

Operation of the air conditioning system in Eco drive mode

In Eco drive mode, the air conditioning system is controlled as follows to prioritise fuel efficiency:

- Engine speed and compressor operation is controlled to restrict the heating / cooling capacity
- The fan speed is restricted when automatic mode is selected

To improve air conditioning performance, perform the following operations:

- Adjust the fan speed
- Turn off Eco drive mode

Customisable features that can be modified

The air conditioning control of Eco drive mode can be changed to the same setting as that used in normal drive mode. Refer to “Customisable features” on page 339.

Using the air conditioning system and defogger

FRONT, SIDE AND REAR VENTS

Front centre vents

Direct air flow to the left or right, up or down.

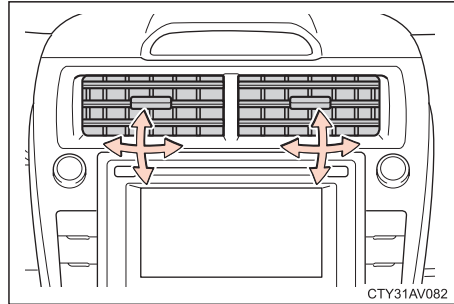

Front side vents

1. Direct air flow to the left or right, up or down.
2. Turn the knob to open or close the vent.

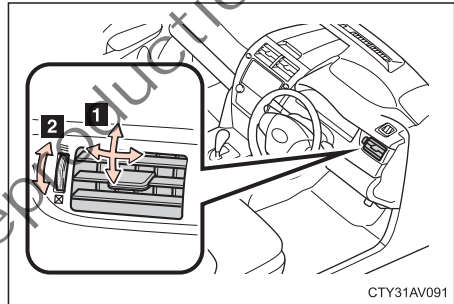

Rear vents

1. Direct air flow to the left or right, up or down.
2. Turn the knob to open or close the vent.

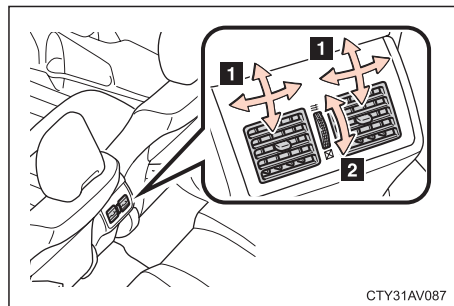

Air conditioning filter

The air conditioning filter must be changed regularly to maintain air conditioning efficiency. Refer to "Air conditioning filter" on page 279.

Using the air conditioning system and defogger

REAR WINDOW DEFOGGER

To defog or defrost the rear window, press the switch.

The system will automatically shut off when the operation time has been completed. The operation time is between 15 minutes and 1 hour depending on the ambient temperature and vehicle speed.

INFORMATION

The defogger can be operated when the POWER switch is in the ON mode.

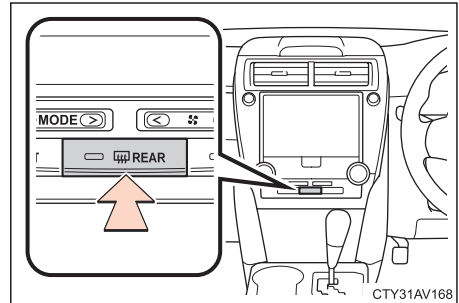

⚠ NOTICE

When cleaning the inside of the rear window, be careful not to scratch or damage the heater wires or connectors.

Not for Reproduction

Touch-screen audio system

Touch-screen audio system

HINT: For vehicles with Navigation system refer to the separate owners manual.

By touching the screen with your finger, you can control the audio system and hands-free system, etc.

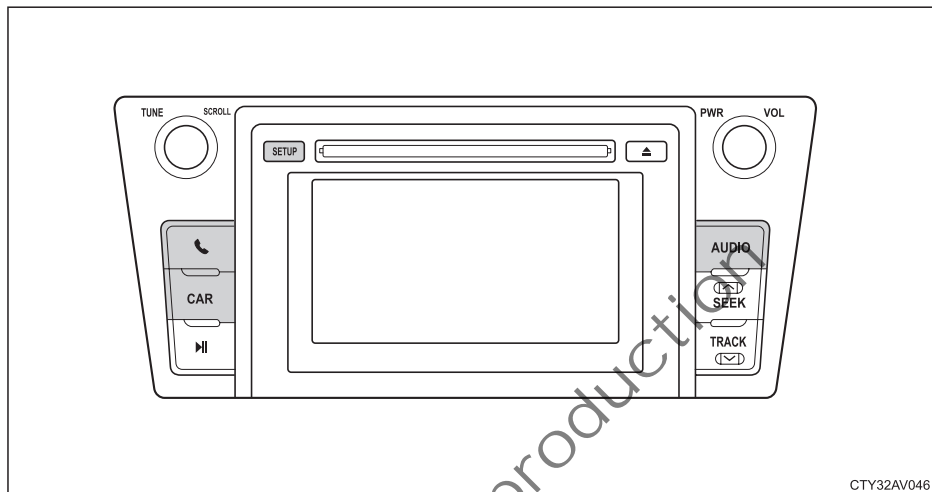

CTY32AV046

QUICK REFERENCE

Button	Function
AUDIO	Audio system, refer to page 176
	Hands-free system, refer to page 211
SETUP	Setup menu, refer to page 171
CAR	Vehicle information, refer to page 174

INFORMATION

To avoid damaging the touch screen

- Touch the screen lightly with your finger. If there is no response, remove your finger from the screen and try again.
- Remove any dirt on the screen by wiping with a soft cloth. Do not use detergent.

When using the touch screen

- If the screen is cold, the display may be dark, or the system may seem to be operating slightly slower than normal.
- The screen may seem dark and hard to see when viewed through sunglasses. Change your angle of viewing, adjust the display on the DISPLAY SETTINGS screen, refer to page 173, or remove your sunglasses.

Touch-screen audio system

SETUP MENU

You can change the Touch-screen audio system to your desired setting.

Press **SETUP** to display the SETUP screen.

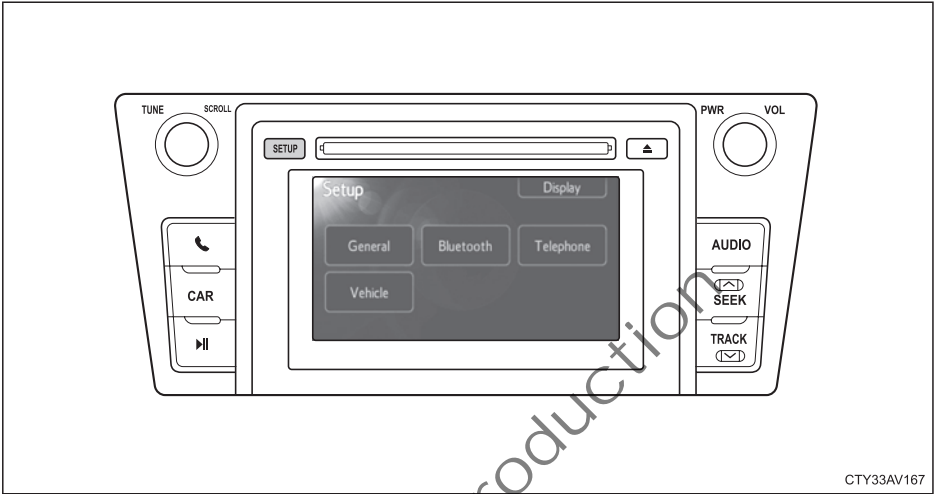

Touch the desired screen button to proceed to the following screens.

Switch	Reference
GENERAL	Refer to page 172
DISPLAY	Refer to page 173
BLUETOOTH	Refer to page 233
TELEPHONE	Refer to page 224
VEHICLE*	Refer to page 174

Bluetooth® is a registered trademark of Bluetooth SIG, Inc.

*Displayed only when the POWER switch is in the ON mode.

Touch-screen audio system

General settings

This screen is used for various settings.

- Press **SETUP**.
- Touch **GENERAL** on the **SETUP** screen.
 - Touch **BEEP** to set **ON / OFF**.
 - Touch **DISPLAY CAPTURED IMAGE** to set **ON / OFF**.
ON or **OFF** can be selected to display captured image / iPod® cover art in the screen.
 - Touch **ANIMATION** to set **ON / OFF**.
 The animation effect for audio source selection screen can be set to **ON** or **OFF**.
 - Personal data can be deleted, refer below.
- When you complete settings, touch **OK**.

Delete personal data—

- Touch **DELETE PERSONAL DATA** on the **GENERAL SETTINGS** screen.
- Touch **DELETE**.
 Check carefully beforehand, as data cannot be retrieved once deleted.
- A confirmation screen will be displayed. Touch **YES**.

The following personal data can be deleted or returned to their default settings:

- Phonebook data
- Call history data
- Speed dial data
- Bluetooth® devices data
- Phone sound settings
- Detailed Bluetooth® settings
- Sound settings

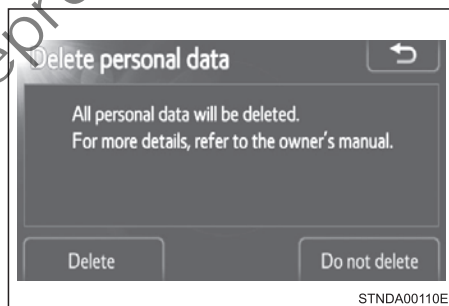
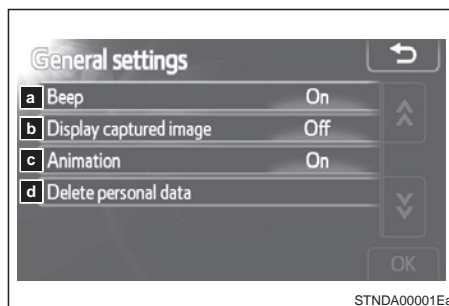

Touch-screen audio system

Display settings

1. Press **SETUP**
2. Touch **DISPLAY** on the **SETUP** screen.
 - a. Turn off screen.
The screen is turned off. To turn it on, press any button such as **AUDIO** or **SETUP**.
 - b. Changes to day mode, refer below.
Displays only when the headlights are set to **ON** or **AUTO**.
 - c. Adjust screen contrast / brightness, refer below.
 - d. Adjust screen contrast / brightness of rear view monitor camera, refer below.

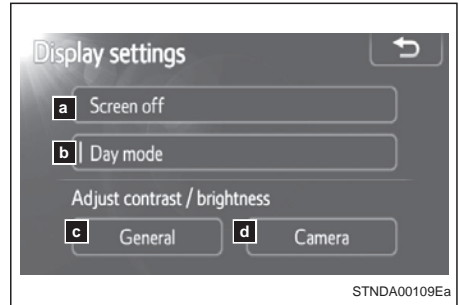

Changing between day mode and night mode—

When the headlights are turned on, the screen dims.

However, the screen can be switched to day mode by touching **DAY MODE**.

The screen will stay in day mode when the headlights are turned on until **DAY MODE** is touched again.

Adjusting the screen contrast / brightness—

1. Touch **GENERAL** or **CAMERA** on the **DISPLAY SETTINGS** screen.
2. Adjust the display as desired using **[+]** or **[-]**.
Select **CONTRAST** or **BRIGHTNESS** using the **[<<]** or **[>>]**.

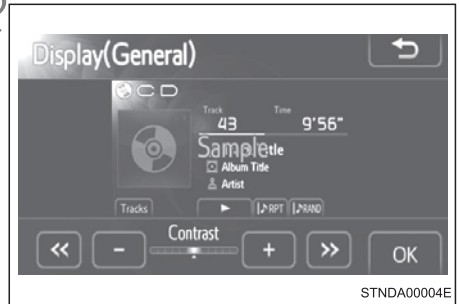

	[-]	[+]
CONTRAST	Weaker	Stronger
BRIGHTNESS	Darker	Brighter

3. Touch **OK**.

Touch-screen audio system

Vehicle settings

1. Press **SETUP**
2. Touch **VEHICLE*** on the **SETUP** screen.

Various settings can be changed.
For details refer to “Customisable features” on page 339.

3. When you complete the settings, touch **OK**.

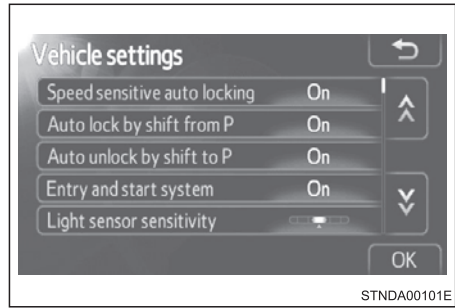

*Displayed only when the **POWER** switch is in the **ON** mode.

VEHICLE INFORMATION

This screen can be used to display the fuel consumption.

Press **CAR** to display the **TRIP INFORMATION** or **PAST RECORD** screen.

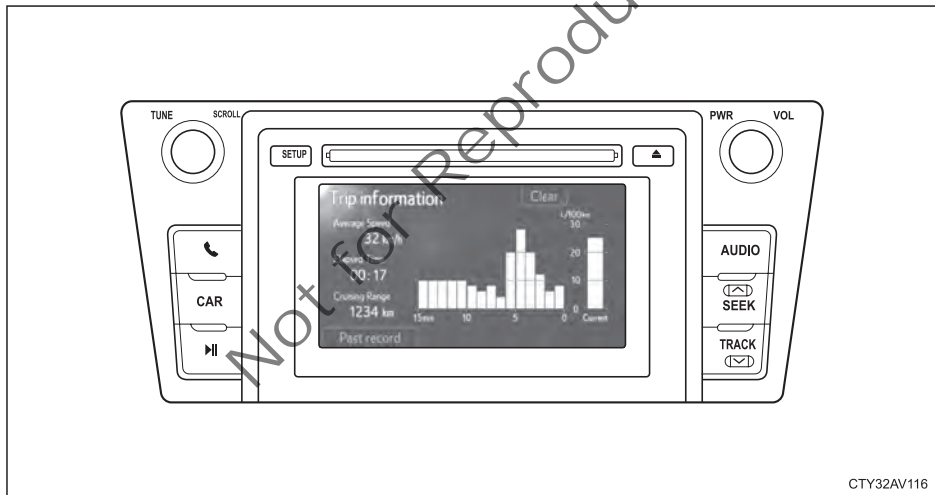

Touch-screen audio system

Fuel consumption

Trip information –

If the TRIP INFORMATION screen does not appear, touch TRIP INFORMATION.

1. Average vehicle speed.
2. Elapsed time.
3. Cruising range.
4. Previous fuel consumption per minute.
5. Current fuel consumption.
6. Reset the trip information data.
7. PAST RECORD screen appears.

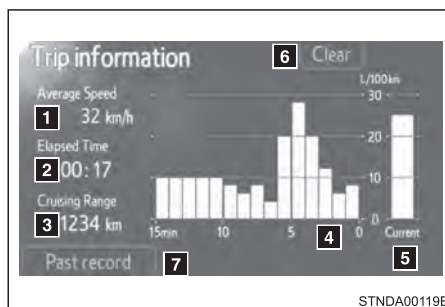

NOTE: These images are examples only, and may vary slightly from actual conditions.

Past record –

If the PAST RECORD screen does not appear, touch PAST RECORD.

1. Previous fuel economy record.
2. Current fuel economy.
3. Best recorded fuel economy.
4. Update the past record data.
5. Reset the past record data.
6. TRIP INFORMATION screen appears.

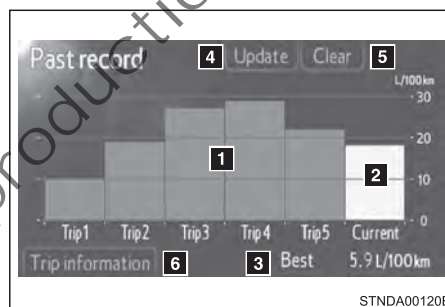

NOTE: These images are examples only, and may vary slightly from actual conditions.

INFORMATION**Resetting the data**

Selecting CLEAR on the TRIP INFORMATION screen will reset the consumption data.

Selecting CLEAR on the PAST RECORD screen will reset the past record data.

Updating the past record data

Selecting UPDATE on the PAST RECORD screen will update the past record data.

Also, the average fuel consumption displayed in the multi-information display will be reset at the same time.

Touch-screen audio system

AUDIO SYSTEM

Press AUDIO to display the audio control screen.

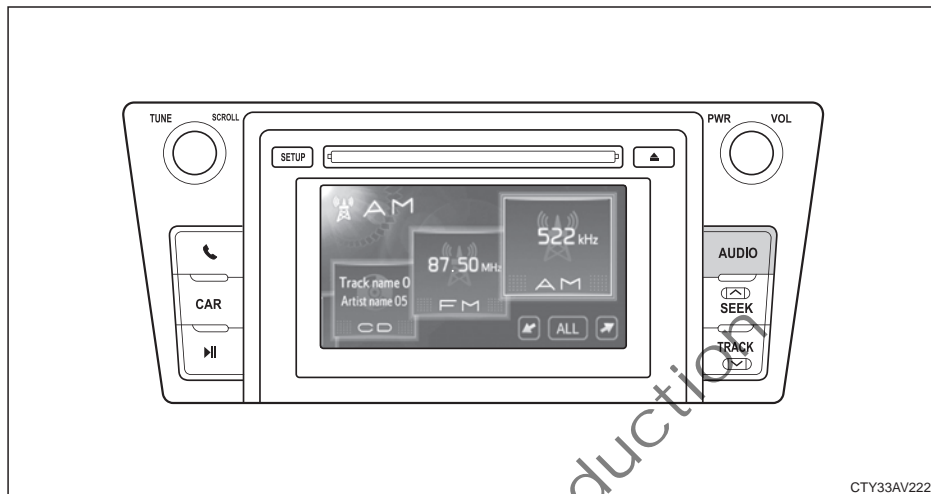

CTY33AV222

Title	Page
Using the radio	Refer to page 179
Using the CD player	Refer to page 181
Playing an audio CD and MP3/WMA discs	Refer to page 181
Listening to an iPod®	Refer to page 189
Listening to a USB memory	Refer to page 194
Using the AUX port	Refer to page 200
Listening to Bluetooth® audio	Refer to page 201
Optimal use of the audio system	Refer to page 208
Using the steering wheel audio switches	Refer to page 209

Touch-screen audio system

Switching the audio source

1. Touch SOURCE or press AUDIO to display the audio source selection screen.

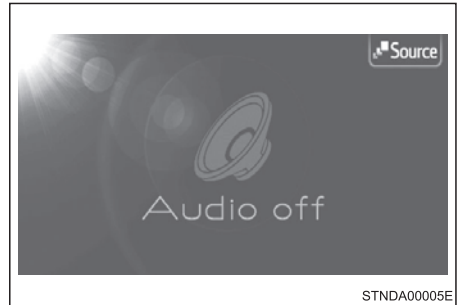

2. Touch the desired audio source.



: To scroll the screen.



: Change to the list style screen as shown below.

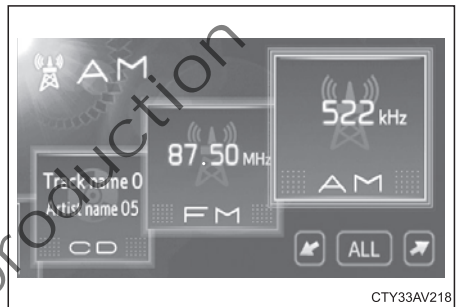

List style screen.

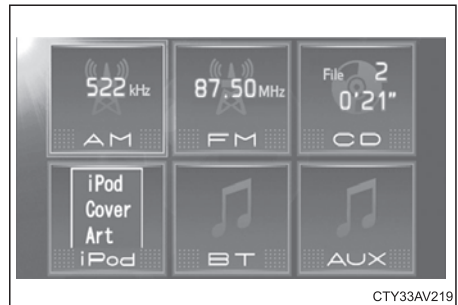





Not for Reproduction

Touch-screen audio system

List screen operation

When a list is displayed, use the appropriate button to scroll through the list.

  : To scroll to the next or previous page.

 : If  appears to the right of titles, the complete titles are too long for the display.

Touch this button to scroll to the title.

Turn TUNE / SCROLL to move the cursor box to select a desired item from the list, and press TUNE / SCROLL to play it. The track that is being played is highlighted.

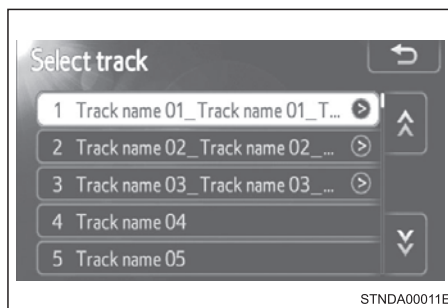

INFORMATION

Using mobile phones

Interference may be heard through the audio system's speakers if a mobile phone is being used inside or close to the vehicle while the audio system is operating.

! CAUTION

Laser product

This product is a class 1 laser product.

- A laser beam leak may result in hazardous radiation exposure.
- Do not open the cover of the player or attempt to repair the unit yourself. Refer servicing to qualified personnel.

! NOTICE

To prevent battery discharge

Do not leave the audio system on longer than necessary when the hybrid system is off.

To avoid damaging the audio system

Take care not to spill drinks or other fluids on the audio system.

Touch-screen audio system

USING THE RADIO

Touch AM or FM on the audio source selection screen.

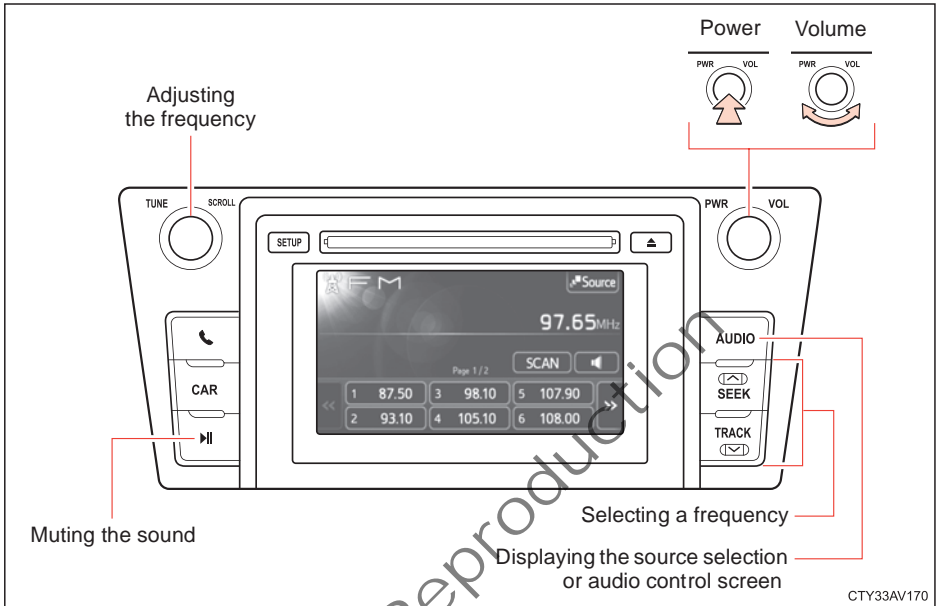

Audio control screen

Pressing AUDIO displays the audio control screen from any screens of the selected source.

1. Audio source selection screen appears.
2. Scanning for receivable station.
3. Setting the sound, refer to page 208.
4. Preset stations.

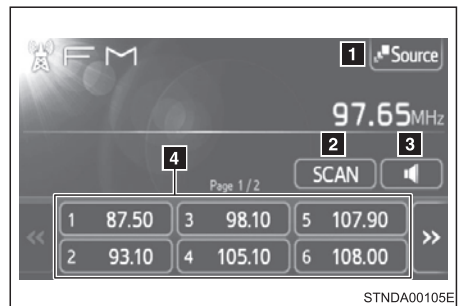

Touch-screen audio system

Selecting a station

Seek tuning—

Press [^] or [v] on SEEK / TRACK.

Manual tuning—

Turn TUNE / SCROLL.

Preset stations—

Touch desired preset stations [1 to 12].

Change the page by using ◀◀ or ▶▶.

Setting station presets

1. Search for desired stations by turning TUNE / SCROLL or pressing [^] or [v] on SEEK / TRACK.
2. Touch and hold one of the preset stations [1 to 12] until you hear a beep.

Scanning radio stations

Scanning the preset radio stations—

1. Touch SCAN on the screen until PSCAN appears.
Preset stations will be played for a few seconds each.
2. Touch SCAN once again when the desired station is reached.

Scanning all radio stations within range—

1. Touch SCAN on the screen.
SCAN appears on the screen and all stations within range will be played for a few seconds each.
2. Touch SCAN once again when the desired station is reached.

INFORMATION

Reception sensitivity

- Maintaining perfect radio reception at all times is difficult due to the continually changing position of the antenna, differences in signal strength and surrounding objects, such as trains, transmitters, etc.
- The radio antenna is mounted inside the rear window. To maintain clear radio reception, do not attach metallic window tinting or other metallic objects to the antenna wire mounted inside the rear window.

Touch-screen audio system

USING THE CD PLAYER

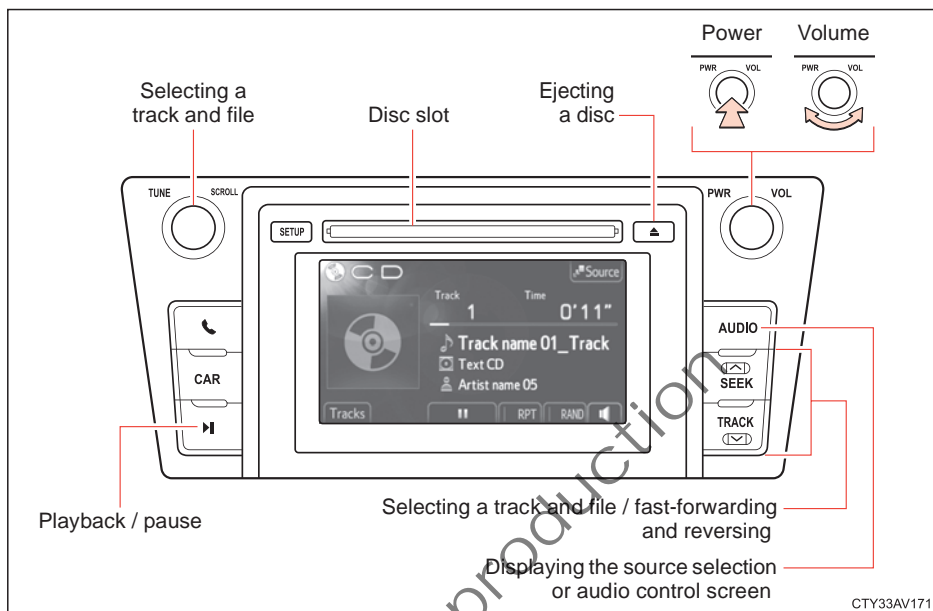
**Loading a disc**

Insert a disc into the disc slot with the label facing up.

Ejecting a disc

Press  and remove the disc.

PLAYING AN AUDIO CD AND MP3 / WMA DISCS

Insert a disc or touch CD on the audio source selection screen with a disc inserted.

Audio control screen

Pressing AUDIO displays the audio control screen from any screens of the selected source.

Audio CD

1. Audio source selection screen appears.
2. Displaying the track / file list.
3. Pause.
(Touch  to play.)
4. Repeat play.
5. Random playback.
6. Setting the sound, refer to page 208.



Touch-screen audio system

MP3 / WMA disc

1. Audio source selection screen appears.
2. Displaying the track / file list.
3. Pause.
(Touch  to play.)
4. Repeat play.
5. Random playback.
6. Displaying the folder list.
7. Setting the sound, refer to page 208.



Selecting, fast-forwarding and reversing tracks (Audio CD)

Selecting a track—

Press [^] or [v] on SEEK / TRACK or turn TUNE / SCROLL to select the desired track number.

To fast-forward or reverse, press and hold [^] or [v] on SEEK / TRACK.

Selecting a track from the track list—

1. Touch TRACKS on the audio control screen.
2. Touch the desired track number.

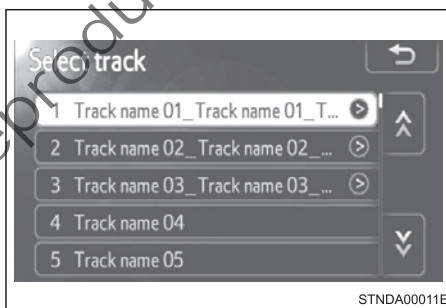

Selecting, fast-forwarding and reversing files (MP3 / WMA disc)

Selecting a file—

Press [^] or [v] on SEEK / TRACK or turn TUNE / SCROLL to select the desired file number.

To fast-forward or reverse, press and hold [^] or [v] on SEEK / TRACK until you hear a beep.

Selecting a file from the file list—

1. Touch FILES on the audio control screen.
2. Touch the desired file number.

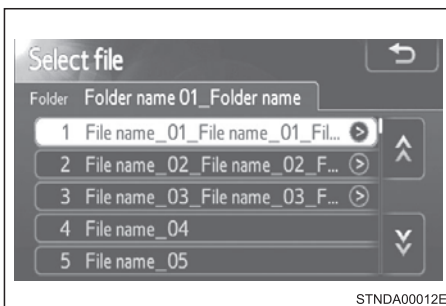

Touch-screen audio system

Selecting a folder (MP3 / WMA disc)

1. Touch FOLDERS on the audio control screen.
2. Touch the desired folder number.

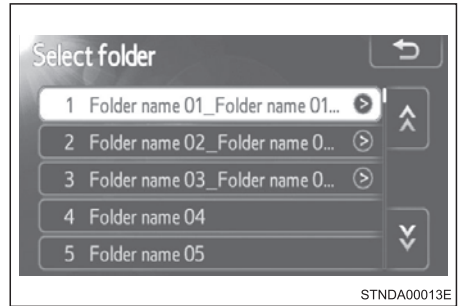

3. Touch the desired file number.

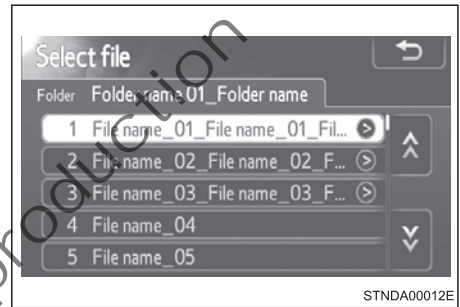

Random playback

Each time **RAND** is touched, the mode changes in the following order:

Audio CD—



MP3/WMA disc—



Repeat play

Each time **RPT** is touched, the mode changes in the following order:

Audio CD—

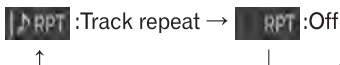

MP3 / WMA disc—



Touch-screen audio system

INFORMATION

Displaying the title and artist name

If a CD-TEXT disc is inserted, the title of the disc and track will be displayed.

Error messages

Refer to the following table and take the appropriate measures. If the problem is not rectified, take the vehicle to your Toyota dealer.

Message	Cause	Correction procedures
CHECK DISC	• The disc is dirty or damaged.	Clean the disc.
	• The disc is inserted upside down.	Insert the disc correctly.
	• The disc is not playable with the player.	Confirm the disc is playable with the player.
DISC ERROR	There is a malfunction within the system.	Eject the disc.
NO MUSIC FILES FOUND	This indicates that no playable data is included in the disc.	Eject the disc.

Discs that can be used

Discs with the marks shown below can be used.

Playback may not be possible depending on recording format or disc features, or due to scratches, dirt or deterioration.



CDs with copy-protection features may not play correctly.

CD player protection feature

To protect the internal components, playback is automatically stopped when a problem is detected.

If a disc is left inside the CD player or in the ejected position for extended periods

The disc may be damaged and may not play properly.

Lens cleaners

Do not use lens cleaners. Doing so may damage the CD player.

INFORMATION

MP3 and WMA files

MP3 (MPEG Audio LAYER3) is a standard audio compression format.

Files can be compressed to approximately 1/10 of their original size by using MP3 compression.

WMA (Windows Media Audio) is a Microsoft audio compression format.

This format compresses audio data to a size smaller than that of the MP3 format.

There is a limit to the MP3 and WMA file standards that can be used and to the media / formats on which the files are recorded.

MP3 file compatibility—

- Compatible standards
MP3 (MPEG1 LAYER3, MPEG2 LSF LAYER3).
- Compatible sampling frequencies
MPEG1 LAYER3: 32, 44.1, 48 (kHz)
MPEG2 LSF LAYER3: 16, 22.05, 24 (kHz).
- Compatible bit rates
MPEG1 LAYER3: 32—320 (kbps)
MPEG2 LSF LAYER3: 8—160 (kbps).
- Compatible channel modes: stereo, joint stereo, dual channel and monaural.

WMA file compatibility—

- Compatible standards
WMA Ver. 7, 8, 9.
- Compatible sampling frequencies
32, 44.1, 48 (kHz)
- Compatible bit rates (only compatible with 3-channel playback)
Ver. 7, 8: CBR 48—192 (kbps)
Ver. 9: CBR 48—320 (kbps).

Compatible media—

Media that can be used for MP3 and WMA playback are CD-Rs and CDRWs.

Playback in some instances may not be possible if the CD-R or CD-RW is not finalised.

Playback may not be possible or the audio may jump if the disc is scratched or marked with fingerprints.

Touch-screen audio system

INFORMATION

Compatible disc formats—

The following disc formats can be used.

- Disc formats: CD-ROM Mode 1 and Mode 2
CD-ROM XA Mode 2, Form 1 and Form 2.
- File formats: ISO9660 Level 1, Level 2, (Romeo, Joliet)
UDF (2.01 or lower).

MP3 and WMA files written in any format other than those listed above may not play correctly, and their file names and folder names may not be displayed correctly.

Items related to standards and limitations are as follows:

- Maximum directory hierarchy: 8 levels (including the root)
- Maximum length of folder names / file names: 32 characters
- Maximum number of folders: 192 (including the root)
- Maximum number of files per disc: 255

File names—

The only files that can be recognised as MP3 / WMA and played are those with the extension .mp3 or .wma.

Discs containing multi-session recordings—

As the audio system is compatible with multi-sessions, it is possible to play discs that contain MP3 and WMA files. However, only the first session can be played.

ID3 and WMA tags—

ID3 tags can be added to MP3 files, making it possible to record the track title, artist name, etc.

The system is compatible with ID3 Ver. 1.0, 1.1, and Ver. 2.2, 2.3 ID3 tags. (The number of characters is based on ID3 Ver. 1.0 and 1.1.)

WMA tags can be added to WMA files, making it possible to record the track title and artist name in the same way as with ID3 tags.

MP3 and WMA playback—

When a disc containing MP3 or WMA files is inserted, all files on the disc are first checked. Once the file check is finished, the first MP3 or WMA file is played. To make the file check finish more quickly, we recommend you do not write in any files other than MP3 or WMA files or create any unnecessary folders.

Discs that contain a mixture of music data and MP3 or WMA format data cannot be played.

INFORMATION

Extensions–

If the file extensions .mp3 and .wma are used for files other than MP3 and WMA files, they will be mistakenly recognised and played as MP3 and WMA files. This may result in large amounts of interference and damage to the speakers.

Playback–

- To play MP3 files with steady sound quality, we recommend a fixed bit rate of 128 kbps and a sampling frequency of 44.1 kHz.
- CD-R or CD-RW playback may not be possible in some instances, depending on the characteristics of the disc.
- There is a wide variety of freeware and other encoding software for MP3 and WMA files on the market, and depending on the status of the encoding and the file format, poor sound quality or noise at the start of playback may result. In some cases, playback may not be possible at all.
- When files other than MP3 or WMA files are recorded on a disc, it may take more time to recognise the disc and in some cases, playback may not be possible at all.
- Microsoft, Windows, and Windows Media are the registered trademarks of Microsoft Corporation in the U.S. and other countries.

Not for Reproduction

Touch-screen audio system

⚠ NOTICE

Discs and adapters that cannot be used

Do not use the following types of discs or 8 cm disc adapters or Dual Discs.

Doing so may damage the player and / or the insert / eject function.

- Discs that have a diameter that is not 12 cm.

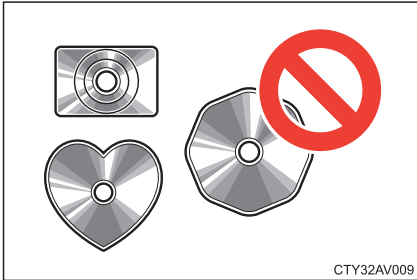

- Low-quality and deformed discs.

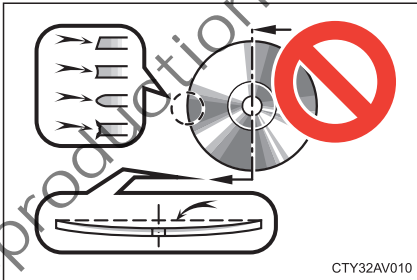

- Discs with a transparent or translucent recording area.

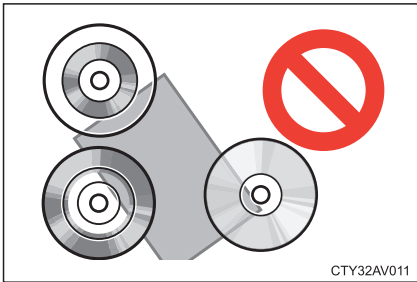

- Discs that have had tape, stickers or CD-R labels attached to them, or that have had the label peeled off.

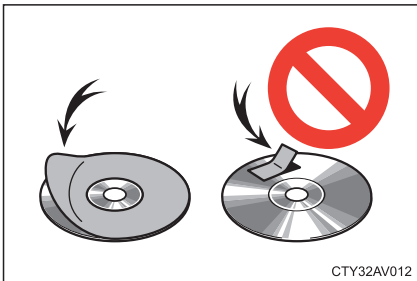

Touch-screen audio system

NOTICE

Player precautions

Failure to follow the precautions below may result in damage to the discs or the player itself.

- Do not insert anything other than discs into the disc slot.
- Do not apply oil to the player.
- Store discs away from direct sunlight.
- Never try to disassemble any part of the player.

LISTENING TO AN iPod®

Connecting an iPod® enables you to enjoy music from the vehicle speakers.

Touch iPod® on the audio source selection screen.

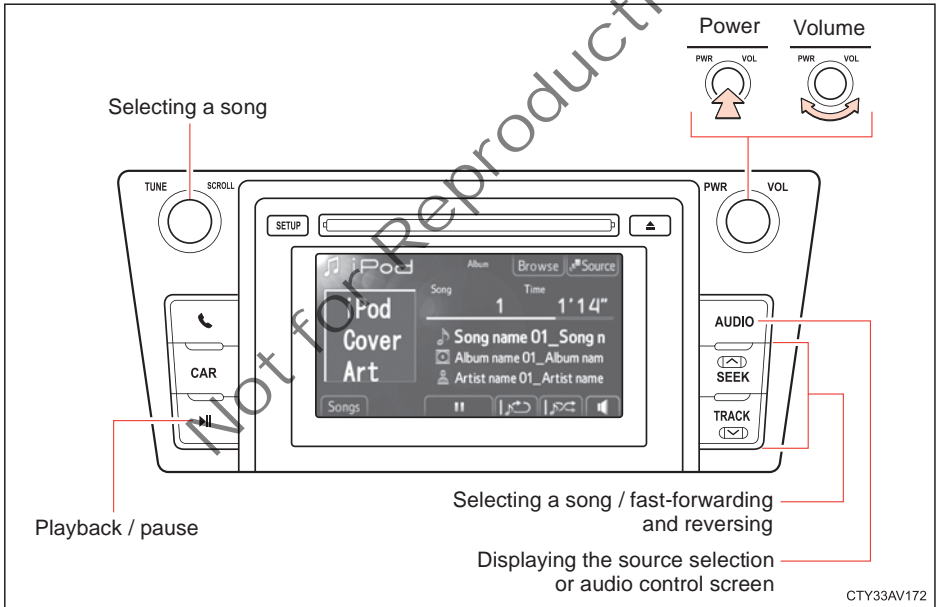

Touch-screen audio system

Audio control screen

Pressing AUDIO displays the audio control screen from any screens of the selected source.

1. Audio source selection screen appears.
2. Selecting the play mode.
3. Displaying the song list.
4. Pause.
(Touch  to playback.)
5. Repeat play.
6. Shuffle play.
7. Setting the sound, refer to page 208.



STNDA00106E

Connecting an iPod®

1. Push the lid.

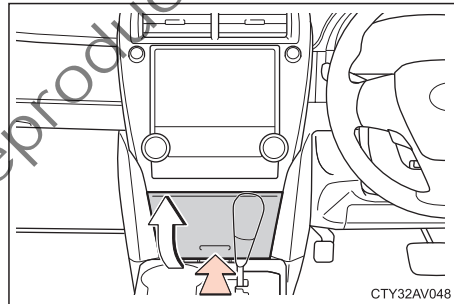

2. Open the cover and connect an iPod® using an iPod® cable.

Turn on the power of the iPod if it is not turned on.

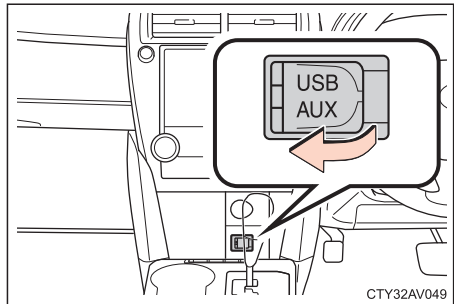

Touch-screen audio system

Playing an iPod®

Play/ Pause–

Touch  or  to Play / Pause.

Selecting a play mode–

1. Touch BROWSE on the audio control screen.
2. Select the desired play mode by touching the PLAYLISTS, ARTISTS, ALBUMS, SONGS, PODCASTS, AUDIO BOOKS, GENRES or COMPOSERS tabs.



Selecting, fast-forwarding and reversing songs

Selecting one song at a time–

Press [\wedge] or [\vee] on SEEK / TRACK or turn TUNE / SCROLL to select the desired song.

To fast-forward or reverse, press and hold [\wedge] or [\vee] on SEEK / TRACK until you hear a beep.



Selecting a song from the list–

1. Touch SONGS on the audio control screen.
2. Touch the desired song.



Shuffle play



Each time  is touched, the mode changes in the following order:

 : Playing the songs in shuffle →  : Playing the albums in the iPod in shuffle →  : Off

When a large number of songs is stored in an iPod®, shuffle selection may take time.

Repeat play

Each time  is touched, the mode changes in the following order:

 : Repeating the song →  : Off

Touch-screen audio system

INFORMATION

About iPod®

- “Made for iPod®” and “Made for iPhone®” means that an electronic accessory has been designed to connect specifically to iPod®, or iPhone®, respectively, and has been certified by the developer to meet Apple performance standards.
- Apple is not responsible for the operation of this device or its compliance with safety and regulatory standards. Please note that the use of this accessory with iPod® or iPhone® may affect wireless performance.
- iPhone®, iPod®, iPod® classic, iPod® nano, iPod® shuffle, and iPod® touch are trademarks of Apple Inc., registered in the U.S. and other countries.



iPod® cover art

- Depending on the iPod® and songs in the iPod®, iPod® cover art may be displayed.
- This function can be changed to ON or OFF, refer to page 172.
- It may take time to display iPod® cover art, and the iPod® may not be operated while the cover art display is in process.
- Only iPod® cover art that is saved in a JPEG format can be displayed.

iPod® functions

- When an iPod® is connected and the audio source is changed to iPod® mode, the iPod® will resume play from the same point in which it was last used.
- Depending on the iPod® that is connected to the system, certain functions may not be available. If a function is unavailable due to a malfunction (as opposed to a system specification), disconnecting the device and reconnecting it once again may resolve the problem.
- While connected to the system, the iPod® cannot be operated with its own controls. It is necessary to use the controls of the vehicle's audio system instead.
- When the battery level of an iPod® is very low, the iPod may not operate. If so, charge the iPod® before use.
- For supported models refer to “Compatible models” on page 193.

iPod® problems

To resolve most problems encountered when using your iPod®, disconnect your iPod® from the vehicle iPod® connection and reset it.

For instructions on how to reset your iPod®, refer to your iPod® Owner's Manual.

INFORMATION

Error messages

CONNECTION ERROR: This indicates a problem in the iPod® or its connection.

THERE ARE NO SONGS AVAILABLE FOR PLAYBACK:

This indicates there is no music data in the iPod®.

NO ITEMS AVAILABLE: This indicates that some available songs are not found in a selected playlist.

Compatible models

The following iPod®, iPod nano®, iPod classic®, iPod touch® and iPhone® devices can be used with this system.

Made for

- iPod touch (1st, 2nd, 3rd and 4th generation)
- iPod classic
- iPod with video
- iPod nano (1st, 2nd, 3rd, 4th, 5th and 6th generation)
- iPhone (iPhone, 3G, 3GS and 4)

Depending on differences between models or software versions etc., some models might be incompatible with this system.

iPod® 4th generation and earlier models are not compatible with this system.

iPod® mini, iPod® shuffle and iPod® photo are not compatible with this system.

CAUTION

Do not connect an iPod® or operate the controls while driving.

NOTICE

If the auxiliary box lid cannot be fully closed

Depending on the size and shape of the iPod® that is connected to the system, the auxiliary box lid may not close fully. In this case, do not forcibly close the lid as this may damage the iPod® or the terminal, etc.

To prevent damage to the iPod or its terminal

- Do not leave the iPod® in the vehicle. The temperature inside the vehicle may become high, resulting in damage to the iPod®.
- Do not push down on or apply unnecessary pressure to the iPod® while it is connected.
- Do not insert foreign objects into the port.

Touch-screen audio system

LISTENING TO A USB MEMORY

Connecting a USB memory enables you to enjoy music from the vehicle speakers.

Touch USB on the audio source selection screen.

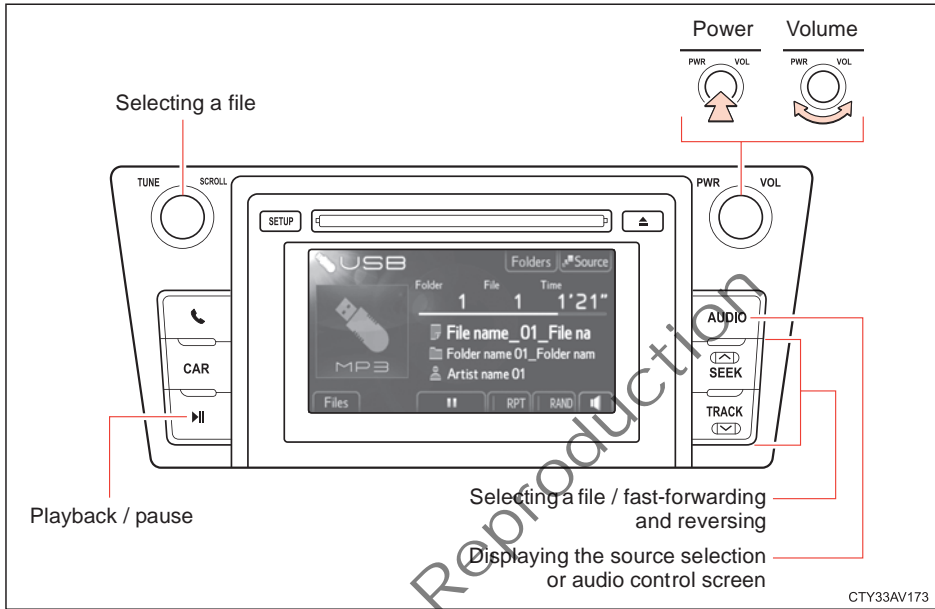

Audio control screen

Pressing AUDIO displays the audio control screen from any screens of the selected source.

1. Audio source selection screen appears.
2. Displaying the folder list.
3. Displaying the file list.
4. Pause.
(Touch  to playback.)
5. Repeat play.
6. Random playback.
7. Setting the sound, refer to page 208.

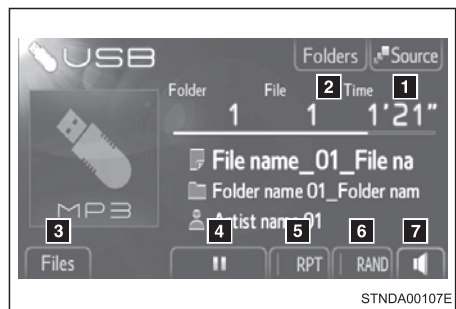

Touch-screen audio system

Connecting a USB memory

1. Push the lid.

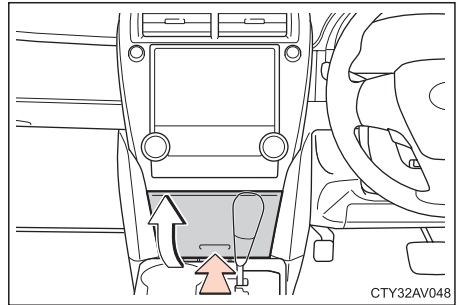

2. Open the cover and connect the USB memory.

Turn on the power of the USB memory if it is not turned on.

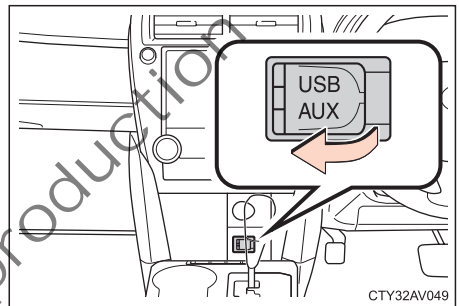
**Selecting, fast-forwarding and reversing files**

Selecting one file at time—

Press [^] or [v] on SEEK / TRACK or turn TUNE / SCROLL to select the desired file.

To fast-forward or reverse, press and hold [^] or [v] on SEEK / TRACK until you hear a beep.

Selecting a file from the list—

1. Touch FILES on the audio control screen.
2. Touch the desired file number.

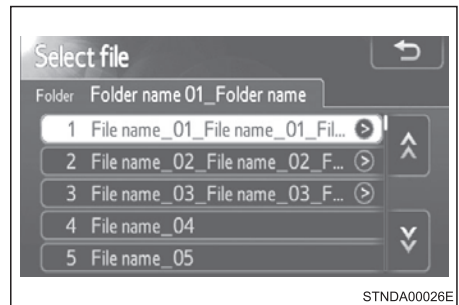

Touch-screen audio system

Selecting a folder

1. Touch FOLDERS on the audio control screen.
2. Touch the desired folder number.

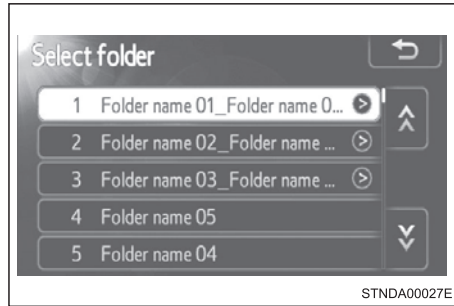

3. Touch the desired file number.

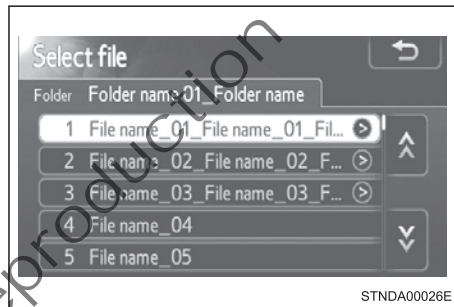

Random playback

Each time **RAND** is touched, the mode changes in the following order:



Repeat play

Each time **RPT** is touched, the mode changes in the following order:



INFORMATION

USB memory functions

- Depending on the USB memory that is connected to the system, the device itself may not be operable and certain functions may not be available. If the device is inoperable or a function is unavailable due to a malfunction (as opposed to a system specification), disconnecting the device and reconnecting it once again may resolve the problem.
- If the USB memory still does not begin operation after being disconnected and reconnected, format the memory.

Error messages

CONNECTION ERROR: This indicates a problem in the USB memory or its connection.
THERE ARE NO FILES AVAILABLE FOR PLAYBACK:

This indicates that no MP3/WMA files are included in the USB memory.

USB memory

Compatible devices—

USB memory that can be used for MP3 and WMA playback.

Compatible device formats—

The following device formats can be used:

- USB communication formats: USB2.0 FS (12 Mbps)
- File formats: FAT16/32 (Windows)
- Correspondence class: Mass storage class
MP3 and WMA files written in any format other than those listed above may not play correctly, and their file names and folder names may not be displayed correctly.

Items related to standards and limitations are as follows:

- Maximum directory hierarchy: 8 levels
- Maximum number of folders in a device: 3000 (including the root)
- Maximum number of files in a device: 9999
- Maximum number of files per folder: 255

Touch-screen audio system

INFORMATION

MP3 and WMA files—

MP3 (MPEG Audio LAYER 3) is a standard audio compression format.

Files can be compressed to approximately 1/10 of their original size using MP3 compression.

WMA (Windows Media Audio) is a Microsoft audio compression format.

This format compresses audio data to a size smaller than that of the MP3 format.

There is a limit to the MP3 and WMA file standards that can be used and to the media / formats on which the files are recorded.

MP3 file compatibility—

- Compatible standards
MP3 (MPEG1 AUDIO LAYERII, III, MPEG2 AUDIO LAYERII, III, MPEG2.5).
- Compatible sampling frequencies
MPEG1 AUDIO LAYERII, III: 32, 44.1, 48 (kHz)
MPEG2 AUDIO LAYERII, III: 16, 22.05, 24 (kHz).
- Compatible bit rates (compatible with VBR)
MPEG1 AUDIO LAYERII, III: 32-320 (kbps)
MPEG2 AUDIO LAYERII, III: 8-160 (kbps).
- Compatible channel modes: stereo, joint stereo, dual channel and monaural.

WMA file compatibility—

- Compatible standards
WMA Ver. 7, 8, 9.
- Compatible sampling frequencies
HIGH PROFILE 32, 44.1, 48 (kHz).
- Compatible bit rates
HIGH PROFILE 48-320 (kbps, VBR).

File names—

The only files that can be recognised as MP3/WMA and played are those with the extension .mp3 or .wma.

ID3 and WMA tags—

ID3 tags can be added to MP3 files, making it possible to record the track title, artist name, etc.

The system is compatible with ID3 Ver. 1.0, 1.1, and Ver. 2.2, 2.3, 2.4 ID3 tags.

(The number of characters is based on ID3 Ver. 1.0 and 1.1.)

WMA tags can be added to WMA files, making it possible to record the track title and artist name in the same way as with ID3 tags.

INFORMATION

MP3 and WMA playback–

- When a device containing MP3 or WMA files is connected, all files in the USB memory are checked. Once the file check is finished, the first MP3 or WMA file is played. To make the file check finish more quickly, we recommend that you do not include any files other than MP3 or WMA files or create any unnecessary folders.
- When the USB memory is connected and the audio source is changed to USB memory mode, the USB memory will start playing the first file in the first folder. If the same device is removed and reinserted (and the contents have not been changed), the USB memory will resume play from the same point in which it was last used.

Extensions–

If the file extensions .mp3 and .wma are used for files other than MP3 and WMA files, they will be skipped (not played).

Playback–

- To play MP3 files with steady sound quality, we recommend a fixed bit rate of at least 128 kbps and a sampling frequency of 44.1 kHz.
- There is a wide variety of freeware and other encoding software for MP3 and WMA files on the market, and depending on the status of the encoding and the file format, poor sound quality or noise at the start of playback may result. In some cases, playback may not be possible at all.
- Microsoft, Windows, and Windows Media are registered trademarks of Microsoft Corporation in the U.S.A. and other countries.

CAUTION

Do not connect a USB memory or operate the controls while driving.

NOTICE

If the auxiliary box lid cannot be fully closed

Depending on the size and shape of the USB memory that is connected to the system, the auxiliary box lid may not close fully. In this case, do not forcibly close the lid as this may damage the USB memory or the terminal, etc.

To prevent damage to the USB memory or its terminal

- Do not leave the USB memory in the vehicle. The temperature inside the vehicle may become high, resulting in damage to the USB memory.
- Do not push down on or apply unnecessary pressure to the USB memory while it is connected.
- Do not insert foreign objects into the port.

Touch-screen audio system

USING THE AUX PORT

This port can be used to connect a portable audio device and listen to it through the vehicle's speakers.

1. Push the lid.

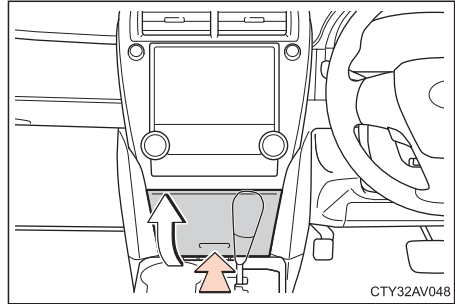

2. Open the cover and connect the portable audio device.
3. Touch AUX on the audio source selection screen.

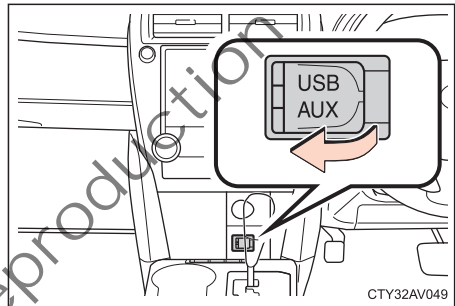

INFORMATION

Operating portable audio devices connected to the audio system

The volume can be adjusted using the vehicle's audio controls. All other adjustments must be made on the portable audio device itself.

When using a portable audio device connected to the power outlet

Noise may occur during playback. Use the power source of the portable audio device.

Touch-screen audio system

LISTENING TO BLUETOOTH® AUDIO

The Bluetooth® audio system enables users to enjoy music played on a portable player from the vehicle speaker via wireless communication. This audio system supports Bluetooth®, a wireless data system capable of playing portable audio music without cables. If your portable player does not support Bluetooth®, the Bluetooth® audio system will not function.

Touch BT on the audio source selection screen.

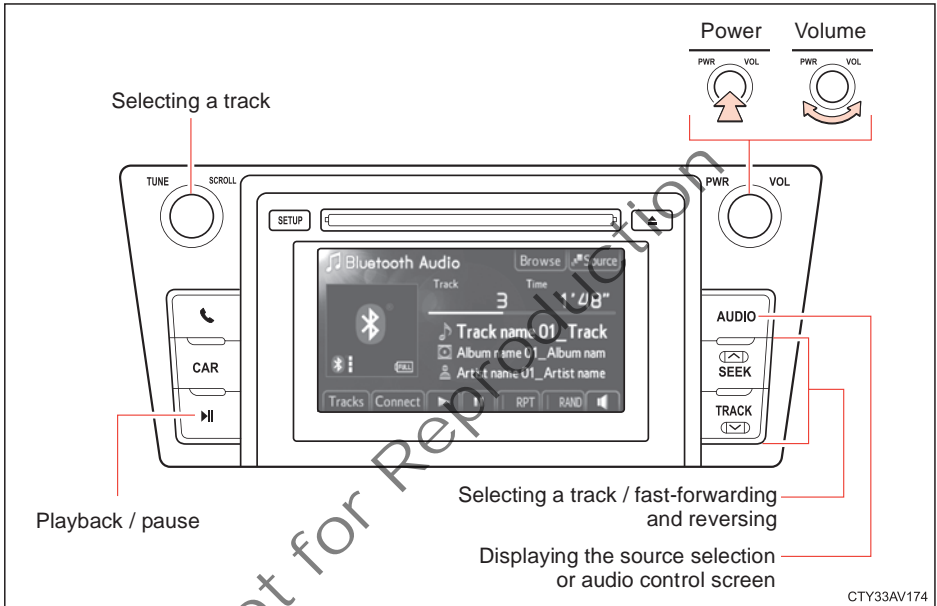

Audio control screen

Pressing AUDIO displays the audio control screen from any screens of the selected source.

1. Audio source selection screen appears.
2. Displaying the album list.
3. Displaying the track list.
4. Connecting a Bluetooth® audio player.
5. Playback.
6. Pause.
7. Repeat play.
8. Random playback.
9. Setting the sound, refer to page 208.

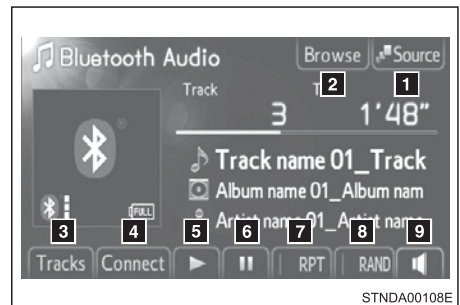

Touch-screen audio system

Status display

You can check such indicators as signal strength and battery charge on the screen.

1. Connection status.
2. Battery charge.



Indicators	Conditions
Connection status	Good ← → Not connected
Battery charge	Full ← → Empty

Registering a Bluetooth® audio player

To use the Bluetooth® audio system, you need to register your portable audio player into the system. Once registered, you can enjoy your music on the vehicle's audio system.

You can register up to 5 devices in the system.

1. Touch **CONNECT** on the BLUETOOTH* AUDIO control screen.

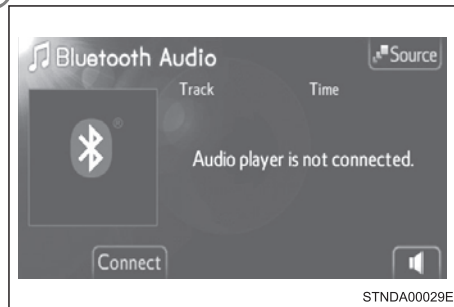

2. Touch **YES**.

*: Bluetooth is a registered trademark of Bluetooth SIG, Inc.



Touch-screen audio system

- Input the passcode displayed on the screen into your portable audio player.

For the operation of the portable audio player, see the manual that comes with your portable audio player.

Passcodes are not required for SSP (Secure Simple Pairing) compatible Bluetooth® devices. Depending on the device, you may need to select YES to register, or NO to cancel on your Bluetooth® device.

If you want to cancel it, select CANCEL.

If a completion message is displayed, registration is complete.

If an error message is displayed, follow the guidance on the screen to try again.

Selecting the Bluetooth® audio player

If multiple Bluetooth® devices are registered, follow the procedure below to select the Bluetooth® device to be used. You may only use one device at a time.

- Touch CONNECT on the BLUETOOTH* AUDIO control screen.

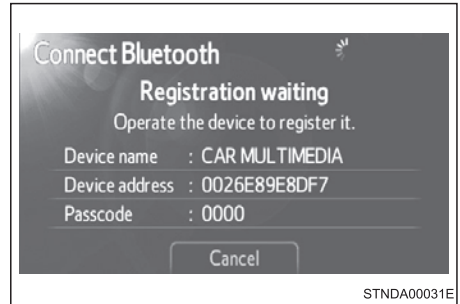

- Touch the device to connect.

ADD NEW: Registering a Bluetooth® device, refer to page 233.

The selection indicator is displayed on left side of the selected device name.

The Bluetooth® mark is displayed when you connect the device.

*: Bluetooth is a registered trademark of Bluetooth SIG, Inc.

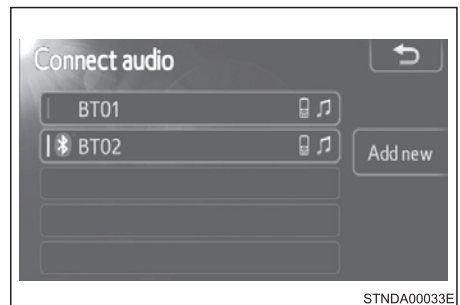

Touch-screen audio system

Connecting the Bluetooth® audio player

There are two connection methods available.

When the connection method is set to FROM VEHICLE—

When the portable audio player is on standby for the connection, it will be automatically connected whenever the POWER switch is in either ACCESSORY or ON mode.

When the connection method is set to FROM AUDIO PLAYER—

Operate the portable player and connect it to the Bluetooth® audio system.

1. Touch CONNECT on the BLUETOOTH* AUDIO control screen.



2. Touch the device to connect.

A message is shown if connection has been successful.

If connection fails, a message will be displayed and connection will be re-attempted.

*: Bluetooth is a registered trademark of Bluetooth SIG, Inc.

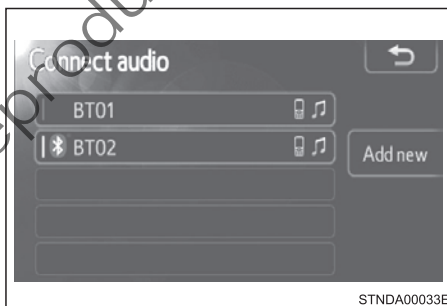

Playing Bluetooth® audio

Touch  or  to play / pause.

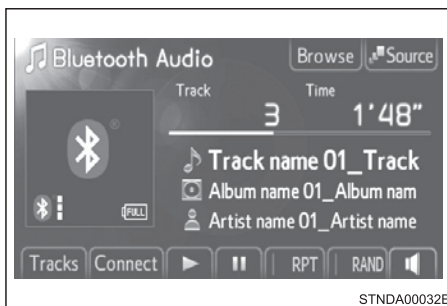

Touch-screen audio system

Some titles and controls may not be displayed depending on the type of portable audio player.

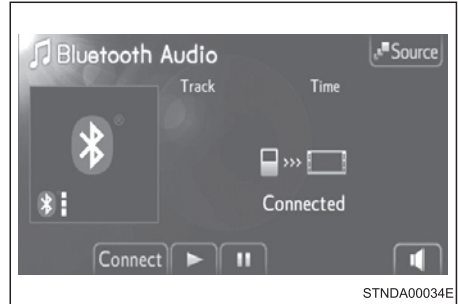

STNDA00034E

Selecting a track

Selecting a track—

Press [^] or [V] on SEEK / TRACK or turn TUNE / SCROLL to select the desired track number.

To fast-forward or rewind, press and hold [^] or [V] on SEEK / TRACK until you hear a beep.

Selecting a track from the list—

1. Touch TRACKS on the BLUETOOTH* AUDIO control screen.
2. Touch the desired track.

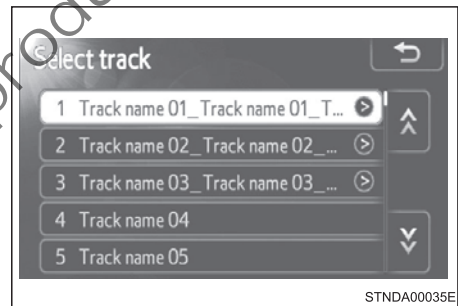

STNDA00035E

Selecting an album

1. Touch BROWSE on the BLUETOOTH* AUDIO control screen.
2. Touch the desired album.

*: Bluetooth is a registered trademark of Bluetooth SIG, Inc.

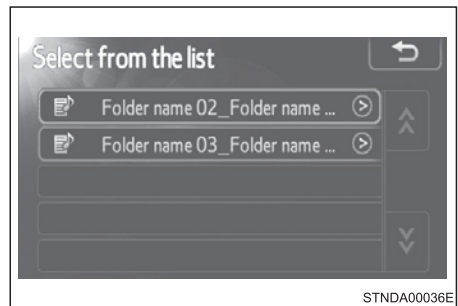

STNDA00036E

Touch-screen audio system

3. Touch the desired track.

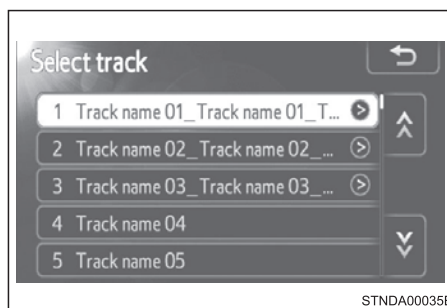

Random playback

Each time **RAND** is touched, the mode changes in the following order:



Repeat play

Each time **RPT** is touched, the mode changes in the following order:

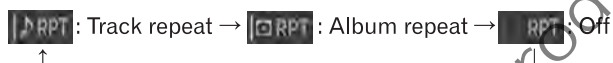

INFORMATION

When using the Bluetooth® audio system

In the following conditions, the system may not function.

- If the portable audio player is turned off.
- If the portable audio player is not connected.
- If the portable audio player's battery is low.

There may be a delay if phone connection is carried out during Bluetooth® audio play.

Depending on the type of portable audio player that is connected to the system, operation may differ slightly and certain functions may not be available.

Bluetooth® antenna

The antenna is built into the display. If the portable audio player is behind the seat or in the glove box or console box, or is touching or covered by metal objects, connection status may deteriorate.

Battery charge / signal status

This display may not correspond exactly with the portable audio player, and this system does not have a charging function.

INFORMATION

About Bluetooth®

Bluetooth is a registered trademark of Bluetooth SIG, Inc.

The Bluetooth wordmark and logo are owned by Bluetooth SIG, and permission has been granted to use the trademark of the licensee FUJITSU TEN LIMITED. Other trademarks and trade names are owned by various different owners.



Compatible models

Portable audio players must correspond to the specifications.

- Bluetooth® specifications:
Ver. 1.1, or higher (recommended: Ver. 2.1 + EDR or higher)
- Profiles:
 - A2DP (Advanced Audio Distribution Profile) Ver. 1.0, or higher (recommended: Ver. 1.2 or higher). This is a profile to transmit stereo audio or high quality sounds to the headphone
 - AVRCP (Audio / Video Remote Control Profile) Ver. 1.0 or higher (recommended: Ver. 1.4 or higher). This is a profile to remote control the A/V equipment
However, please note that some functions may be limited depending on the type of portable audio player

Reconnecting the portable audio player

If the portable audio player is disconnected with a poor reception when the POWER switch is in ACCESSORY or ON mode, the system automatically reconnects the portable audio player.

If you have switched off the portable audio player yourself, follow the instructions below to reconnect.

- Select the portable audio player again.
- Enter the portable audio player.

When transferring ownership of the vehicle

Initialise the system to prevent personal data from being improperly accessed, refer to page 172.

CAUTION

Do not use the portable audio player or connect the Bluetooth® system while driving.

Touch-screen audio system

NOTICE

When leaving the vehicle

Do not leave your portable audio player in the vehicle. The inside of the vehicle may become hot, causing damage to the portable audio player.

OPTIMAL USE OF THE AUDIO SYSTEM

Touch  to adjust the sound settings.



STNDA00037E

SOUND tab

- 1, 2, 3. Touch [-] or [+] to adjust the treble, mid or bass to a level between [-5 to 5].
- 4, 5. Touch FRONT or REAR to adjust the front / rear audio balance to a level between Front 7 and Rear 7.
- 6, 7. Touch L or R to adjust the left / right audio balance to a level between L7 and R7.

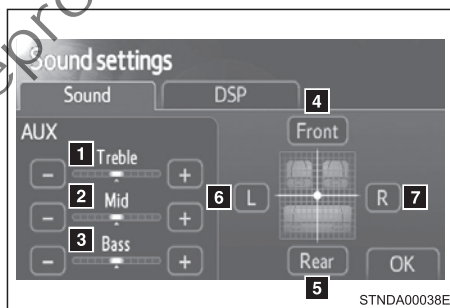

STNDA00038E

DSP tab

1. Automatic sound leveliser (ASL)
Adjust the ASL level in the order of HIGH, MID, LOW or OFF.

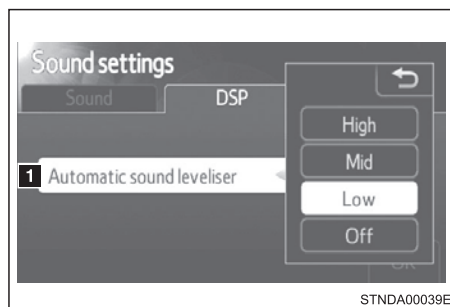

STNDA00039E

INFORMATION

The sound quality level is adjusted individually

The treble, mid and bass levels can be adjusted for each audio mode separately.

About Automatic Sound Leveliser (ASL)

ASL automatically adjusts the volume and tone quality according to the vehicle speed.

USING THE STEERING WHEEL AUDIO SWITCHES

Some audio features can be controlled using the switches on the steering wheel.

1. Increases / decreases volume.
2. Returns to the previous screen.
3. Radio mode:
Selects radio stations.
- CD mode:
Selects tracks / files and folders (MP3/WMA).
- iPod® mode:
Selects songs.
- USB memory mode:
Selects files and folders.
- Bluetooth® audio mode:
Selects tracks and albums.
- List screen:
Moves cursor.
4. Turns the power on, selects audio source.
5. Radio mode:
Displays the preset screen.
- Media mode:
Displays the list screen
- List screen:
Selects items.

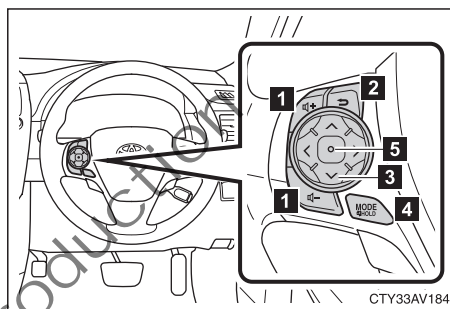

Turning on the power

Press MODE when the audio system is turned off.

Changing the audio source

Press MODE when the audio system is turned on. The audio source changes as follows each time MODE is pressed. If no discs are inserted in the player, or if the external device is not connected, that mode will be skipped.

FM → CD player → iPod® / USB memory → Bluetooth® audio → AUX → AM.

Adjusting the volume

Press [+] to increase the volume and [-] to decrease the volume.

Hold the button in that position to continue increasing or decreasing the volume.

Touch-screen audio system

Silencing a sound

Press and hold MODE.

To cancel, press and hold MODE.



Returning to the previous screen

Press  to display the previous screen.



Displaying the preset screen (radio)

1. Press MODE to select the radio mode.
2. Press  to display the preset screen.

Selecting a radio station

1. Press MODE to select the radio mode.
2. Press [\wedge] or [\vee] on  to select a radio station.
To seek stations, press and hold [\wedge] or [\vee] on  until you hear a beep.
The radio preset page can be changed by pressing [$>$] or [$<$] on  (FM mode only).

Selecting a track / file or song

1. Press MODE to select the CD, Bluetooth® audio, iPod®, USB memory mode.
2. Press [\wedge] or [\vee] on  to select the desired track / file or song.
To return to the beginning of the track / file or song, press [\vee] on  once quickly.



Selecting a folder or album

1. Press MODE to select the CD (only when MP3 / WMA disc is in use), Bluetooth® audio, iPod® or USB memory mode.
2. Press [$>$] or [$<$] on  to select the desired folder or album.

Displaying the list screen

1. Press MODE to select CD, Bluetooth® audio, iPod® or USB memory mode.
2. Press  to display the list screen.

Operating on the list screen

1. Press [\wedge] or [\vee] on  to move the cursor up or down.
2. Press  to select an item.

When the folder or album is selected, the SELECT FILE screen is displayed.

CAUTION

To reduce the risk of an accident

Exercise care when operating the audio switches on the steering wheel.

HANDS-FREE SYSTEM (FOR MOBILE PHONES)

The hands-free system is a function that allows you to use your mobile phone without touching it.

This system supports Bluetooth®. Bluetooth® is a wireless data system that allows the mobile phone to wirelessly connect to the hands-free system and make / receive calls.

Telephone switch

1. Off hook switch
 - Sending.
 - Receiving.
 - TELEPHONE screen display.
2. On hook switch
 - End call.
 - Refuse call.
3. Volume switch
 - Increase the volume.
 - Decrease the volume.
 - TELEPHONE screen display.
4. Back
 - Return to the previous screen.
5. Cursor switch
 - Selects lists.
 - Selects tabs.
6. Enter switch
 - Select items.

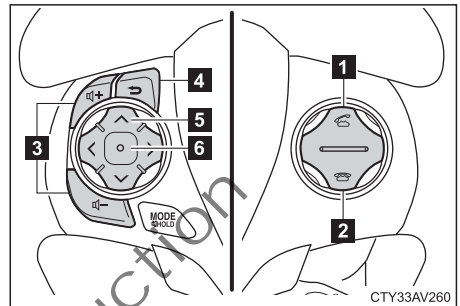

Microphone

You can use the microphone when talking on the phone.

The person you are speaking to can be heard from the front speakers.

To use the hands-free system, you must register your Bluetooth® phone in the system, refer to page 215.

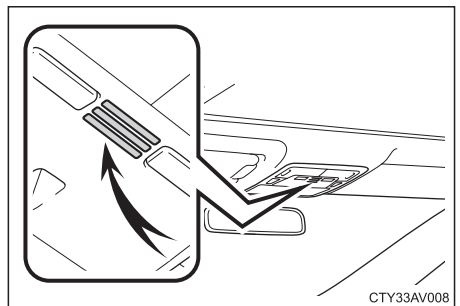







Touch-screen audio system

Status display

You can check indicators such as signal strength and battery charge on the TELEPHONE screen.

1. Connection status.
2. Battery charge.
3. Call area.
4. Signal strength.



Indicators	Conditions
Connection status	Good ← Not connected  
Battery charge	Full ← Empty  
Call area	Rm: Roaming area
Signal strength	Excellent ← Poor  

INFORMATION

When using the hands-free system

- The audio system is muted when making a call.
- If both parties speak at the same time, it may be difficult to hear.
- If the received call volume is overly loud, an echo may be heard.
 If the Bluetooth® phone is too close to the system, quality of the sound may deteriorate and connecting condition may go down.
- In the following circumstances, it may be difficult to hear the other party.
 - When driving on unpaved roads.
 - When driving at high speeds.
 - If a window is open.
 - If the air conditioning is blowing directly on the microphone.
 - There is an effect from the network of the mobile phone.

INFORMATION

Conditions under which the system will not operate

- If using a mobile phone that does not support Bluetooth®.
- If the mobile phone is turned off.
- If you are outside service range.
- If the mobile phone is not connected.
- If the mobile phone's battery is low.
- When outgoing is controlled, due to heavy traffic on telephone lines, etc.
- When the mobile phone itself cannot be used.
- When transferring the phonebook data from the mobile phone.

Bluetooth® antenna

The antenna is built into the display. If the mobile phone is behind the seat or in the console box, or touching or covered by metal objects, connection status may deteriorate.

Battery charge / Signal status

- This display may not correspond exactly with the mobile phone itself.
- This system does not have a charging function.
- The Bluetooth® phone battery will be depleted quickly when it is connected to Bluetooth®.
- When the mobile phone is not connected, NO CONNECT is displayed.
- When you are out of service area or in a place inaccessible by radio waves, NO SERVICE is displayed.

When using Bluetooth® audio and hands-free system at the same time

The following problems may occur.

- The Bluetooth® connection may be cut.
- Noise may be heard on the Bluetooth® audio playback.

About the phonebook in this system

The following data is stored for every registered phone. When another phone is connected, you cannot read the registered data.

- Phonebook data.
- All of call history.
- Speed dial.

When you delete the phone, the above-mentioned data is also deleted.

When transferring ownership of the vehicle

Initialise the system to prevent personal data from being improperly accessed, refer to page 172.

Touch-screen audio system

INFORMATION

About Bluetooth®

Bluetooth is a registered trademark of Bluetooth SIG, Inc.

The Bluetooth wordmark and logo are owned by Bluetooth SIG, and permission has been granted to use the trademark of the licensee FUJITSU TEN LIMITED.

Other trademarks and trade names are owned by various different owners.



Compatible models

This system supports the following service.

- Bluetooth® Specification:
Ver. 1.1 or higher (Recommended: Ver. 2.1+EDR or higher)
- Profiles:
 - HFP (Hands Free Profile) Ver. 1.0 or higher (Recommended: Ver. 1.5 or higher)
This is a profile to allow hands-free phone calls using the mobile phone or head sets. It has an outgoing and incoming call function.
 - OPP (Object Push Profile) Ver. 1.1 or higher.
This is a profile to exchange phonebook data. When the Bluetooth® phone has PBAP and OPP, OPP cannot be used.
 - PBAP (Phone Book Access Profile) Ver. 1.0 or higher.
This is a profile to transfer phonebook data.

If your mobile phone does not support HFP, you cannot enter the Bluetooth® phone. You need to take OPP or PBAP service individually.

! CAUTION

Do not use the mobile phone or connect the Bluetooth® system while driving.

! NOTICE

When leaving the vehicle

Do not leave your mobile phone in the vehicle. The inside of the vehicle may become hot, causing damage to the phone.

USING THE BLUETOOTH® PHONE

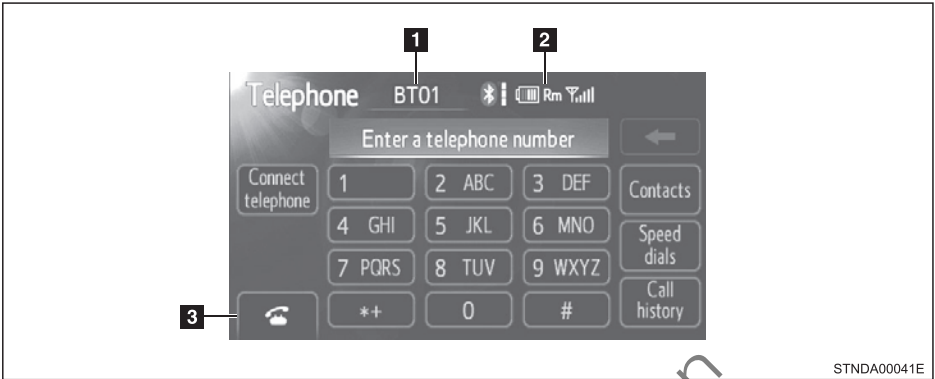

STNDA00041E

1	Device name	3	Make a call
2	Bluetooth® connection status		

To display the TELEPHONE screen shown above, press on the steering wheel or .

Registering a Bluetooth® phone

To use the hands-free system, you must register a Bluetooth® phone in the system. You can register up to 5 phones in the system.

1. Display the TELEPHONE screen.
2. Touch YES.

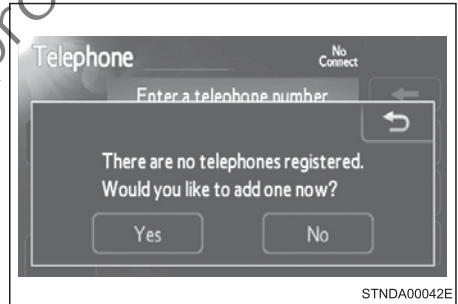

STNDA00042E

3. Input the passcode displayed on the screen into your phone.
For the operation of the phone, see the manual that comes with your mobile phone.

Passcodes are not required for SSP (Secure Simple Pairing) compatible Bluetooth® devices. Depending on the phone, you may need to select YES to register, or NO to cancel on your mobile phone.

If you want to cancel it, select CANCEL.

If a completion message is displayed, registration is complete.

If an error message is displayed, follow the guidance on the screen to try again.

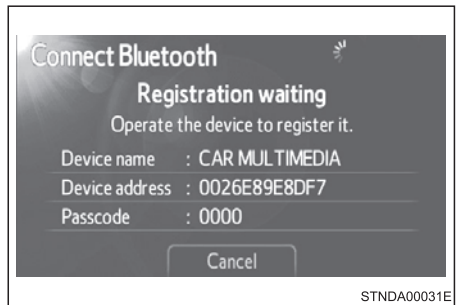

STNDA00031E

Touch-screen audio system

Selecting the Bluetooth® phone

If multiple Bluetooth® devices are registered, follow the procedure below to select the Bluetooth® device to be used. You may only use one device at a time.

1. Touch **CONNECT TELEPHONE** on the **TELEPHONE** screen.



2. Touch the device to connect.

ADD NEW: Registering a Bluetooth® device, refer to page 233.

The selection indicator is displayed on left side of the selected device name.

The Bluetooth® mark is displayed when you connected the device.

When the system cannot get the device names, alternate names will be displayed such as DEVICE1, DEVICE2, etc.

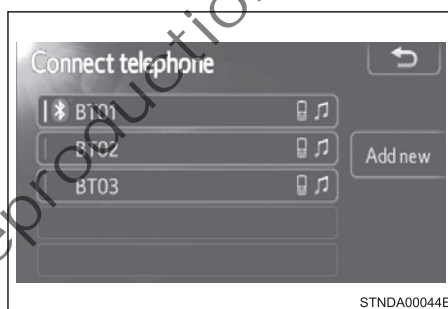

Connecting a Bluetooth® phone

There are two connecting methods available - automatic and manual.

Automatic—

When you register your phone, auto connection will be activated. Always set it to this mode and leave the Bluetooth® phone in a place where connection can be established. When the **POWER** switch is in **ACCESSORY** or **ON** mode, the system will search for a nearby mobile phone you have registered.

Next, the system automatically connects with the most recent of the phones connected to in the past. Then, the connection result is displayed.

Touch-screen audio system

Manual–

When the auto connection has failed or Bluetooth* power is turned off, you must connect Bluetooth® manually.

1. Touch CONNECT TELEPHONE on the TELEPHONE screen.



2. Touch the device to connect.

A message is shown if connection has been successful.

If connection fails, a message will be displayed and connection will be re-attempted.



INFORMATION

Reconnecting to the Bluetooth® phone

If the system cannot connect due to poor signal strength with the POWER switch in ACCESSORY or ON mode, the system will automatically attempt to reconnect.

If the phone is turned off, the system will not attempt to reconnect. In this case, connection must be made manually, or the phone must be re-selected.

Connecting the phone while Bluetooth® audio is playing

- Bluetooth® audio will stop temporarily.
- It may take time to connect.



*: Bluetooth is a registered trademark of Bluetooth SIG, Inc.

Touch-screen audio system

Making a call

Once the Bluetooth® phone is registered, you can make a call using the following procedure:

Dialing –

1. Input the phone number on the TELEPHONE screen.
To delete the inputted phone number, touch .
To enter + as the first digit, prolong the touch on [+].
2. Press  on the steering wheel or touch  on the screen.





Dialing from the phonebook –

You can dial a number from the phonebook data imported from your mobile phone. The system has one phonebook for each telephone. Up to 1000 entries may be stored in each phonebook, refer to page 225.

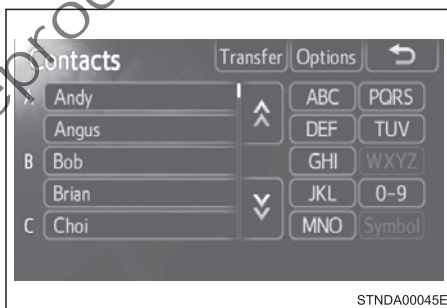
1. Touch CONTACTS on the TELEPHONE screen.
2. Choose the desired data to call from the list.
If the phonebook is empty, a message will be displayed, refer to page 219.



3. Choose the number and then press  on the steering wheel or touch  on the screen.

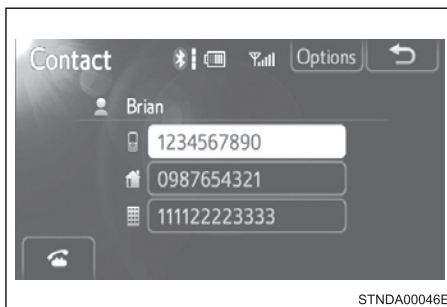

Touch-screen audio system

When the phonebook is empty—

You can transfer the phone numbers in your Bluetooth® phone to the system.

Operation methods differ between PBAP compatible and PBAP incompatible Bluetooth® phones. If your mobile phone does not support either PBAP or OPP service, you cannot transfer contacts.

1. Touch CONTACTS on the TELEPHONE screen.
2. If the phonebook is empty, a message will be displayed.



3. *For a PBAP compatible Bluetooth® phone—*

Touch YES if you want to transfer new contacts from a mobile phone.

Touch NO if you want to cancel transferring the contacts.

For a PBAP incompatible and OPP compatible Bluetooth® phone—

Touch TRANSFER if you want to transfer new contacts from a mobile phone.

Touch CANCEL if you want to cancel transferring the contacts.

You need to operate your phone to transfer new contacts.

Calling using speed dial—

You can make a call using numbers registered from the phonebook.

1. Touch SPEED DIAL on the TELEPHONE screen.
Select the desired tab and choose the desired number to make a call.

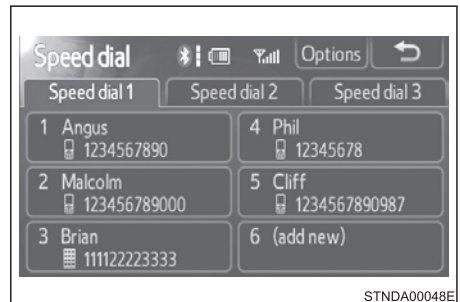

Touch-screen audio system

Dialing from history –

You can call using the call history which has the following 4 functions.

ALL: all the calls below which were memorised.



MISSED: calls which you missed.

INCOMING: calls which you received.

OUTGOING: calls which you made.

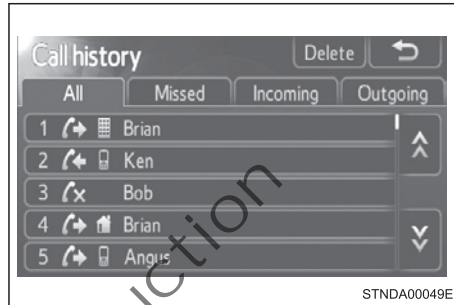
1. Touch **CALL HISTORY** on the **TELEPHONE** screen.
2. Select the desired tab and choose the desired data from the list.



3. Press  on the steering wheel or touch  on the screen.

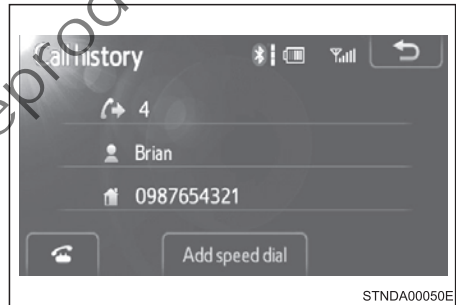

INFORMATION

Call history list

- If you make a call to or receive a call from a number registered in the phonebook, the name is displayed in the call history.
- If you make multiple calls to the same number, only the last call made is displayed in the call history.

When driving

The functions **DIALING**, **DIALING FROM THE PHONEBOOK**, and **DIALING FROM HISTORY** (except for calls using the 5 most recently called numbers shown by **ALL** tab) are unavailable.





International calls

You may not be able to make international calls, depending on the mobile phone in use.

Touch-screen audio system

INFORMATION



Calling by using the latest call history item

1. Press  on the steering wheel to display the TELEPHONE screen.
2. Press  on the steering wheel to display the CALL HISTORY screen.
3. Press  on the steering wheel to select the latest history item.
4. Press  on the steering wheel or touch  on the screen to call the latest history item.



Receiving a call

When a call is received, the following screen is displayed together with a sound.

To answer the phone:

- Press  on the steering wheel or,
- Touch  on the screen.

To refuse a call

- Press  on the steering wheel or,
- Touch  on the screen.

To adjust the incoming call volume—

Touch [-] or [+]. You can also adjust the volume using the steering switches or volume knob.



INFORMATION

International calls

Received international calls may not be displayed correctly depending on the mobile phone in use.

Speaking on the phone

The following screen is displayed when speaking on the phone.

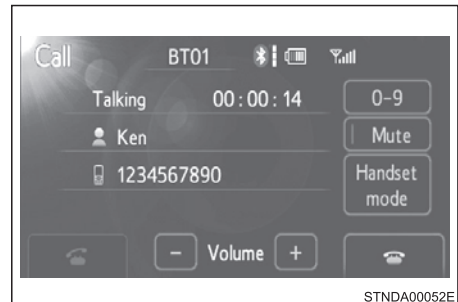

Touch-screen audio system

To adjust the incoming call volume—

Touch [-] or [+]. You can also adjust the volume using the steering switches or the volume knob.

To prevent the other party from hearing your voice—

Touch MUTE.

Inputting tones—

When using phone services such as an answering service or a bank, you can store phone numbers and code numbers in the phonebook.

1. Touch [0-9].
2. Input the number.



STNDA00053E

3. If repeated tone symbols* are stored in the phone book, SEND and EXIT are displayed on the right side of the screen.

: Repeated tone symbols are symbols or numbers displayed as p or w, that come after the phone number. (e.g. 056133w0123p#1)

4. Confirm the number displayed on the screen, and touch SEND.

If you touch EXIT, this function will end.



STNDA00054E

To transfer a call—

Touch HANDSET MODE to change from hands-free call to mobile phone call.

Touch HANDS-FREE MODE to change from mobile phone call to hands-free call.

To hang up—



Press  on the steering wheel or touch  on the screen.

Touch-screen audio system



Call waiting



When a call is interrupted by a third party while talking, the incoming call message will be displayed.

To talk with the other party:

- Press  on the steering wheel or,
- Touch  on the screen.

To refuse the call:

- Press  on the steering wheel or,
- Touch  on the screen.

Every time you press  on the steering wheel or touch  on the screen during call waiting, you will be switched to the other party.

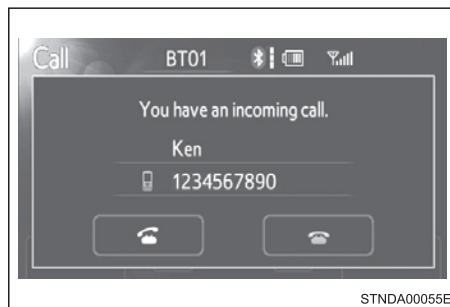

STNDA00055E

INFORMATION

Transferring calls

- It is not possible to transfer from hands-free to the mobile phone while driving.
- If you transfer from the mobile phone to hands-free, the hands-free screen will be displayed, and you can operate the system using the screen.
- Transfer method and operation may vary according to the mobile phone used.
- For operation of the mobile phone in use, see the phone's manual.

Call waiting operation

Call waiting operation may differ depending on your phone company and mobile phone.

Touch-screen audio system

SETTING THE HANDS-FREE SYSTEM

You can set the hands-free system to your desired settings.

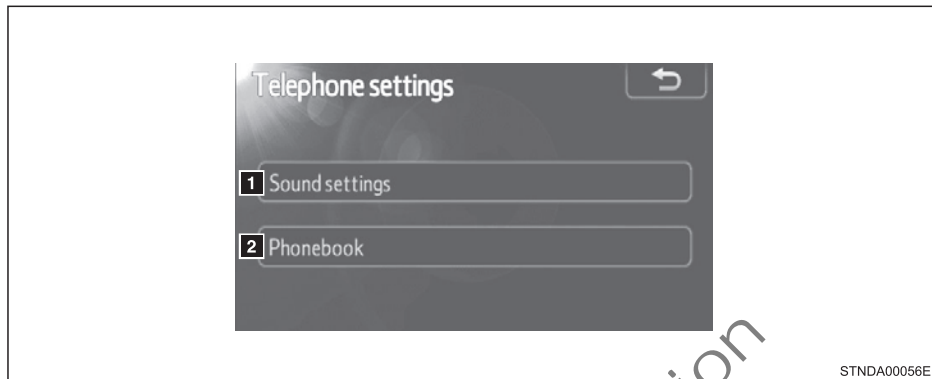

STNDA00056E

1. Setting the sound.
2. Phonebook settings.

To display the TELEPHONE SETTINGS screen shown above, press SETUP, and touch TELEPHONE on the SETUP screen.

Setting the sound

1. Touch SOUND SETTINGS on the TELEPHONE SETTINGS screen.
 - a. Changes the speaker volume.
 - b. Changes the ring tone volume.
 - c. Changes the ring tone.
 - d. Restore default settings.

HINT: Refer to the following procedures for details.

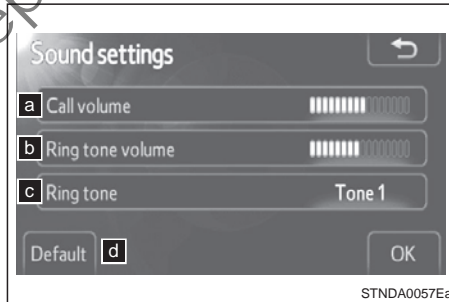

STNDA00057Ea

Setting the volume—

1. Touch CALL VOLUME or RING TONE VOLUME on the SOUND SETTINGS screen.
2. Touch [-] or [+] to lower or raise the volume, and then OK.
3. When you complete all settings, touch OK.

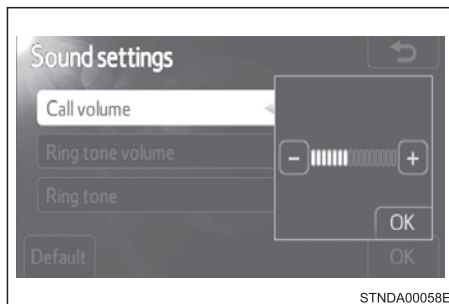

STNDA00058E

Touch-screen audio system

Setting the ring tone–

1. Touch RING TONE on the SOUND SETTINGS screen.
2. Touch TONE 1, TONE 2 or TONE 3 to change the ring tone, and then OK.
3. When you complete all settings, touch OK.

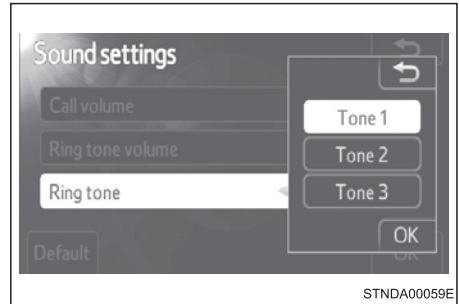

STNDA00059E

INFORMATION

To return to the default volume settings

Touch DEFAULT, and then YES.

Phonebook settings

The phonebook manages a maximum of 5 phones in total. The data for 1000 contacts (up to 3 numbers per contact) can be registered in each phonebook.

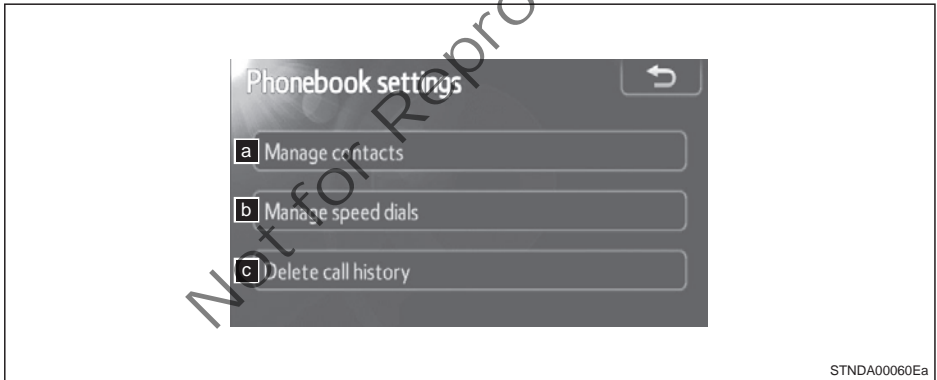

STNDA00060Ea

To display the screen above, follow the steps below.

1. Display the TELEPHONE SETTINGS screen, refer to page 224.
2. Touch PHONEBOOK on the TELEPHONE SETTINGS screen.
 - a. Managing the contacts.
 - b. Managing the speed dials.
 - c. Deleting the call history.

Touch-screen audio system

Managing the contacts –

Transferring a phone number:

You can transfer the phone numbers in your Bluetooth® phone to the system. Operation methods differ between PBAP compatible and PBAP incompatible Bluetooth® phones. If your mobile phone does not support either PBAP or OPP services, you cannot transfer contacts.

1. Touch **MANAGE CONTACTS** on the **PHONEBOOK SETTINGS** screen.
2. Touch **TRANSFER CONTACTS**.

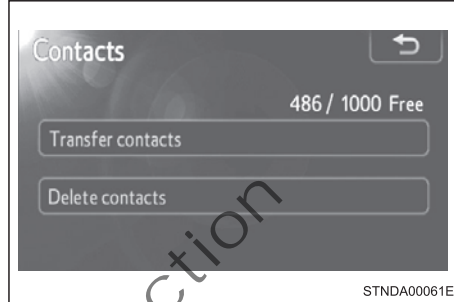

STNDA00061E

3. *For PBAP compatible Bluetooth® phones –*

Touch required selection.

- a. Automatic phonebook download on / off.
The phonebook data can be automatically transferred. Depending on the mobile phone, call history will be also transferred.

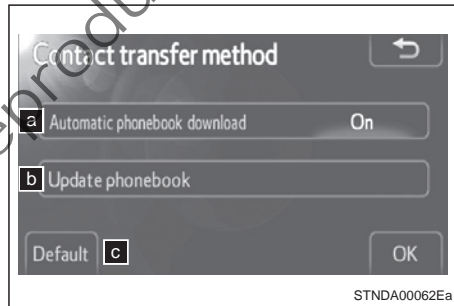

STNDA00062Ea

- b. Update phonebook.
The phonebook data can be updated.
- c. Restore default settings.

For PBAP incompatible Bluetooth® phones –

Touch required selection.

- a. Replace contacts.
The phonebook data can be replaced.
- b. Add contacts
The phonebook can be added.

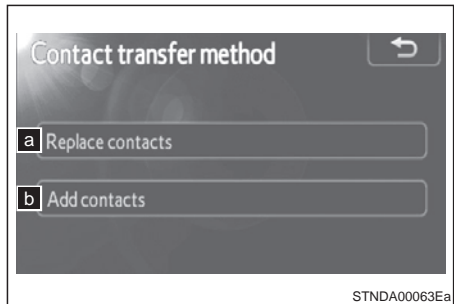

STNDA00063Ea

Touch-screen audio system

Deleting the phonebook data:

1. Touch **MANAGE CONTACTS** on the **PHONEBOOK SETTINGS** screen.
2. Touch **DELETE CONTACTS**.
If your phone supports PBAP service, **AUTOMATIC PHONEBOOK DOWNLOAD** setting needs to be set to **OFF**, refer to page 226.

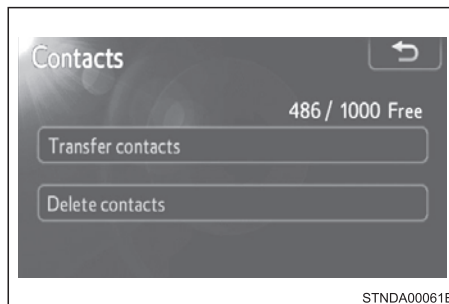

STNDA00061E

3. Choose the data to delete.
To delete all data, touch **ALL DELETE**.
4. A confirmation message will be displayed. If everything is correct, touch **YES**.

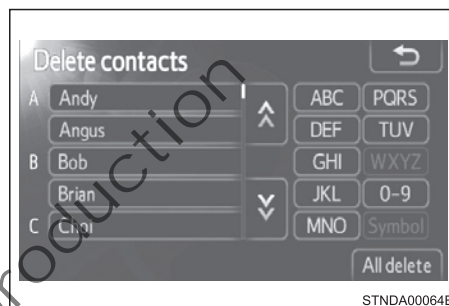

STNDA00064E

INFORMATION

Phonebook data

Phonebook data is managed for every registered phone. When another phone is connecting, you cannot read the registered data.

Setting the phonebook in a different way (To display the **CONTACTS** screen)

1. Display the **TELEPHONE** screen, refer to page 215.
2. Touch **CONTACTS** on the **TELEPHONE** screen.
3. Touch **OPTIONS** on the **CONTACTS** screen.
4. Touch **MANAGE CONTACTS** on the **PHONEBOOK SETTINGS** screen.

When transferring a phone number

Transfer the phone number while the hybrid system is operating.

If your mobile phone is OPP or PBAP compatible, you may need to input [1234] by your mobile phone for OBEX certification.

When you have selected **UPDATE PHONEBOOK** to transfer the phone number

- If your mobile phone does not support PBAP service, you cannot use this function.
- If your phone supports PBAP service, you can transfer the phonebook data without operating your phone.

Touch-screen audio system

INFORMATION

When you have selected REPLACE CONTACTS or ADD CONTACTS to transfer the phone number

If your mobile phone does not support OPP service, you cannot use these functions. You can transfer the phonebook data only by operating your phone

Transferring the phone number in a different way (To display the CONTACT TRANSFER METHOD screen)

1. Display the TELEPHONE screen, refer to page 215.
2. Touch CONTACTS on the TELEPHONE screen.
3. Touch TRANSFER on the CONTACTS screen.

Transferring the phone number while Bluetooth® audio is playing

Bluetooth® audio will disconnect. It will reconnect automatically when data transfer finishes. It may not reconnect, depending on the phone you are using.

Deleting the phonebook data in a different way

1. Display the TELEPHONE screen, refer to page 215.
2. Touch CONTACTS on the TELEPHONE screen.
3. Choose the desired data from the list.
4. Touch OPTIONS on the CONTACT screen.
5. Touch DELETE on the CONTACT DATA screen.
6. A confirmation message will be displayed. If everything is correct, touch YES.

If your phone supports PBAP service, AUTOMATIC PHONEBOOK DOWNLOAD setting needs to be set to OFF, refer to page 226.

When you delete a Bluetooth® phone, the phonebook data will be deleted at the same time.

Managing the speed dials—

Registering the speed dial from contacts:

You can register the desired phone number from the phonebook. Up to 18 numbers per phone can be registered.

1. Touch MANAGE SPEED DIALS on the PHONEBOOK SETTINGS screen.
2. Touch NEW SPEED DIAL FROM CONTACTS.

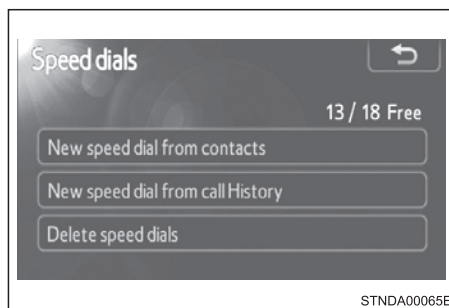

Touch-screen audio system

3. Choose the data to register.

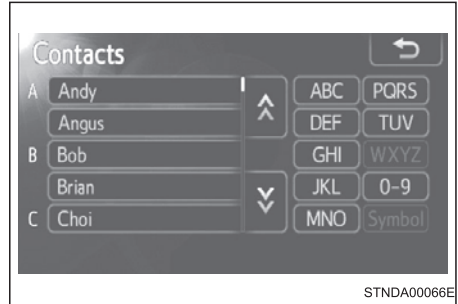

4. Touch the desired phone number.



5. Touch the switch you want to register the number in.
6. If you select a switch you registered before, a confirmation message will be displayed. If you want to replace it, touch YES.

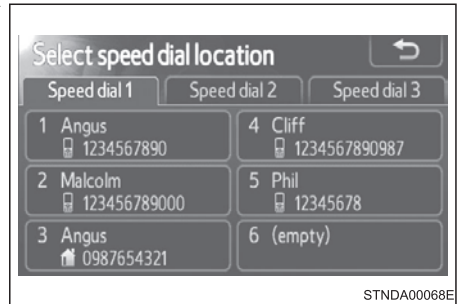

Registering the speed dial from call history:

1. Touch MANAGE SPEED DIALS on the PHONEBOOK SETTINGS screen.
2. Touch NEW SPEED DIAL FROM CALL HISTORY.

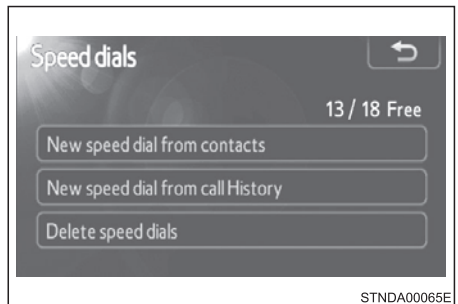

Touch-screen audio system

3. Choose the data to register.



4. Touch the switch you want to register the number in.
5. If you select a switch you registered before, a confirmation message will be displayed. If you want to replace it, touch YES.

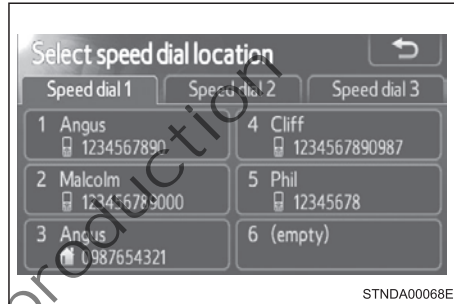

Deleting the speed dial:

1. Touch **MANAGE SPEED DIALS** on the **PHONEBOOK SETTINGS** screen.
2. Touch **DELETE SPEED DIALS** on the **SPEED DIALS** screen.
3. Choose the data to delete.
To delete all data, touch **ALL DELETE**.
4. A confirmation message will be displayed. If everything is correct, touch **YES**.

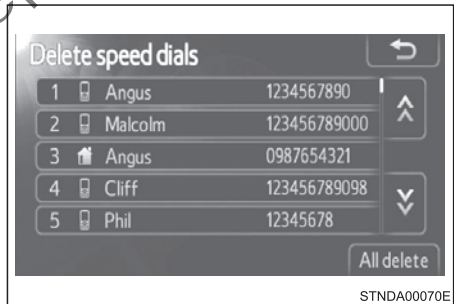

INFORMATION

Setting the speed dials in a different way (From **SPEED DIAL** screen)

1. Display the **TELEPHONE** screen, refer to page 215.
2. Touch **SPEED DIALS** on the **TELEPHONE** screen.
3. Touch **OPTIONS** on the **SPEED DIAL** screen.

INFORMATION

Setting the speed dials in a different way (From CONTACTS screen)

1. Display the TELEPHONE screen, refer to page 215.
2. Touch CONTACTS on the TELEPHONE screen.
3. Touch OPTIONS on the CONTACTS screen.
4. Touch MANAGE SPEED DIALS on the PHONEBOOK SETTINGS screen.

Registering the speed dial in a different way (From SPEED DIAL screen)

1. Display the TELEPHONE screen, refer to page 215.
2. Touch SPEED DIALS on the TELEPHONE screen.
3. Touch (ADD NEW) on the SPEED DIAL screen.
4. Touch CONTACTS or HISTORY to set new speed dial.
Touch CANCEL to cancel it.
5. Choose the desired data from the list.
6. Touch the desired phone number.
7. Follow the steps REGISTERING THE SPEED DIAL FROM CONTACTS from Step 6 on page 229 or REGISTERING THE SPEED DIAL FROM CALL HISTORY from Step 5 on page 230.

Registering the speed dial in a different way (From CONTACT screen)

1. Display the TELEPHONE screen, refer to page 215.
2. Touch CONTACTS on the TELEPHONE screen.
3. Choose the desired data from the list.
4. Touch OPTIONS on the CONTACT screen.
5. Touch SET SPEED DIAL on the CONTACT DATA screen.
6. Touch the desired telephone number.
7. Follow the steps REGISTERING THE SPEED DIAL FROM CONTACTS from Step 6 on page 229 or REGISTERING THE SPEED DIAL FROM CALL HISTORY from Step 5 on page 230.

Registering the speed dial in a different way (From CALL HISTORY screen)

1. Display the TELEPHONE screen, refer to page 215.
2. Touch CALL HISTORY on the TELEPHONE screen.
3. Choose the desired data from the list.
4. Touch ADD SPEED DIAL on the CALL HISTORY screen.
5. Follow the steps REGISTERING THE SPEED DIAL FROM CONTACTS from Step 6 on page 229 or REGISTERING THE SPEED DIAL FROM CALL HISTORY from Step 5 on page 230.

Touch-screen audio system

Deleting the call history–

1. Display the PHONEBOOK SETTINGS screen, refer to page 225.
2. Touch DELETE CALL HISTORY on the PHONEBOOK SETTINGS screen.

If your phone supports PBAP service, the AUTOMATIC PHONEBOOK DOWNLOAD setting needs to be set to OFF, refer to page 226.

3. Choose the desired history to delete.
4. Choose the data to delete.

To delete all data, touch ALL DELETE.

5. A confirmation message will be displayed. If everything is correct, touch YES.

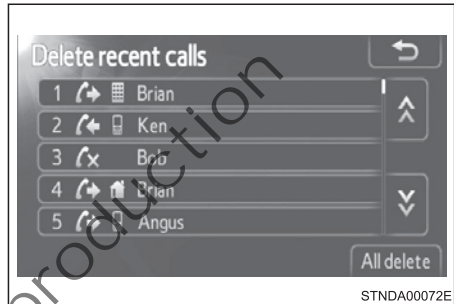
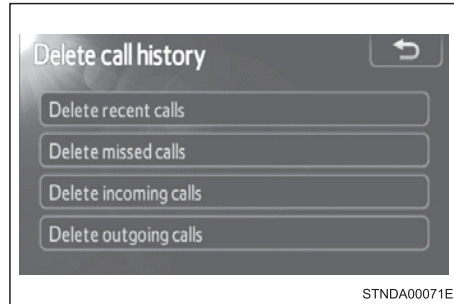

INFORMATION

Deleting call history in a different way

1. Display the TELEPHONE screen, refer to page 215.
2. Touch CALL HISTORY on the TELEPHONE screen.
3. Touch DELETE on the CALL HISTORY screen.
4. Follow the steps DELETING THE CALL HISTORY above.

BLUETOOTH® SETTINGS

You can set the Bluetooth® system to your desired settings.

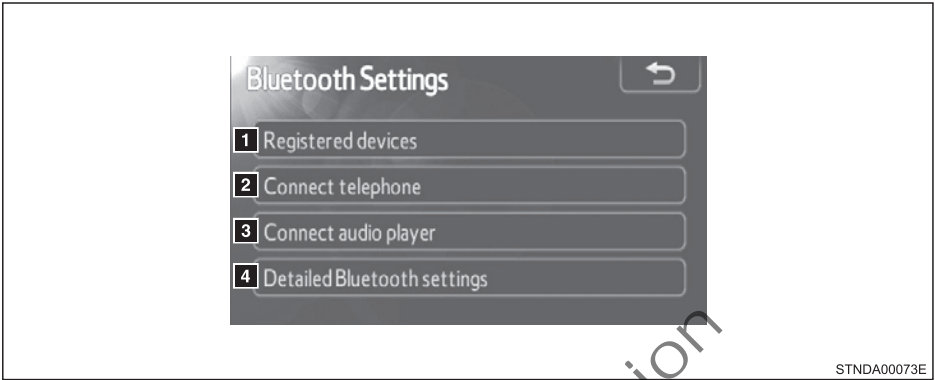

STNDA00073E

1	Registered devices settings	3	Connecting audio player
2	Connecting telephone	4	Detailed Bluetooth® settings

To display the BLUETOOTH* SETTINGS screen shown above, press SETUP, and touch BLUETOOTH* on the SETUP screen.

Registered devices settings

Registering a Bluetooth® device—

Bluetooth® devices compatible with phones (HFP) and portable audio players (AVP) can be registered simultaneously. You can register up to 5 Bluetooth® devices.

1. Touch REGISTERED DEVICES on the BLUETOOTH SETTINGS screen.
2. Touch ADD NEW.

*: Bluetooth is a registered trademark of Bluetooth SIG, Inc.

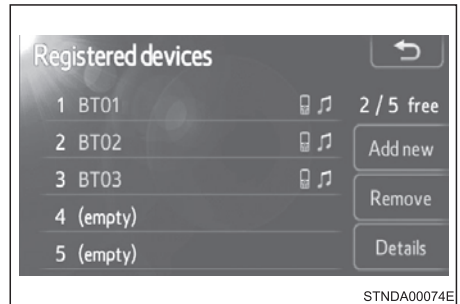

STNDA00074E

Touch-screen audio system

- When this screen is displayed, input the passcode displayed on the screen into your Bluetooth® device.

For the operation of the Bluetooth® device, see the manual that comes with your Bluetooth® device.

Passcodes are not required for SSP (Secure Simple Pairing) compatible Bluetooth® devices. Depending on the phone, you may need to select YES to register, or NO to cancel on your mobile phone.

If you want to cancel it, touch CANCEL.

If a completion message is displayed, registration is complete.

If an error message is displayed, follow the guidance on the screen to try again.

Removing a Bluetooth® device—

- Touch REGISTERED DEVICES on the BLUETOOTH* SETTINGS screen.
- Touch REMOVE.

- Touch the device to remove.
- A confirmation message will be displayed, touch YES to remove the device.

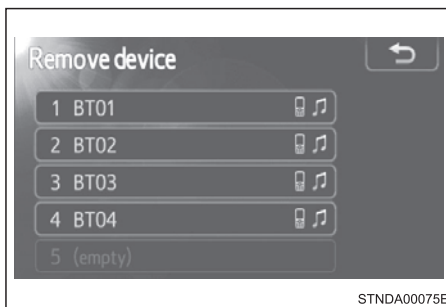
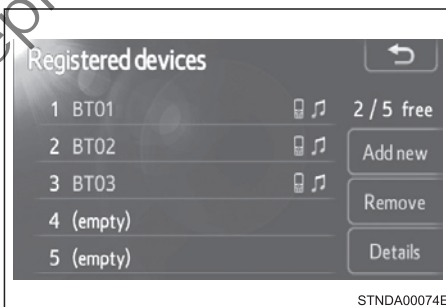
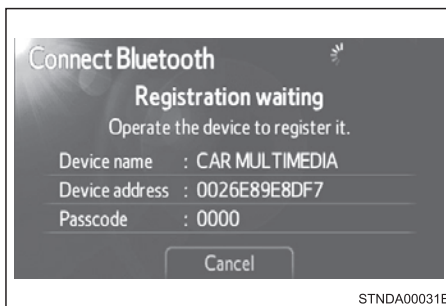

*: Bluetooth is a registered trademark of Bluetooth SIG, Inc.

Touch-screen audio system

Displaying a Bluetooth® device details—

You can confirm and change the device details.

1. Touch REGISTERED DEVICES on the BLUETOOTH* SETTINGS screen.
2. Touch DETAILS.

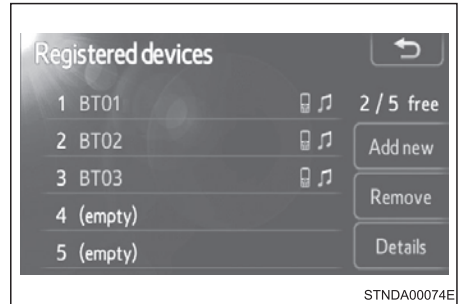

3. Touch the device.

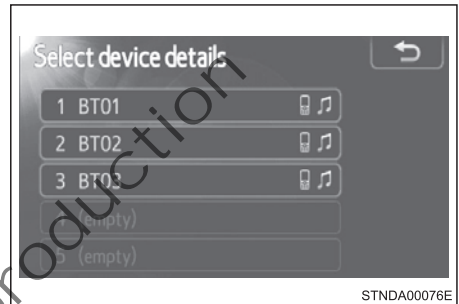

4. The following screen is displayed:
 - a. Display device name.
 - b. Display device address.
 - c. Display your telephone number.
The number may not be displayed depending on the phones.
 - d. Display compatibility profile of the device.
 - e. Change connection method, refer to page 236.
 - f. Restore default settings.

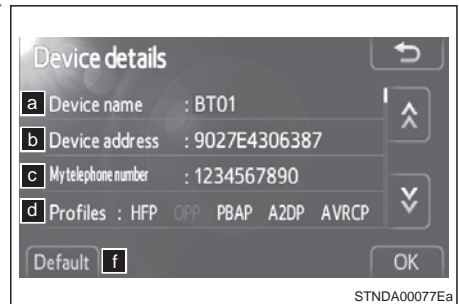

5. When you complete settings, touch OK.

*: Bluetooth is a registered trademark of Bluetooth SIG, Inc.



Touch-screen audio system

Changing connection method:

1. Touch CONNECTION METHOD on the DEVICE DETAILS screen.
2. Touch FROM VEHICLE or FROM AUDIO PLAYER.

FROM VEHICLE: Connect the audio system to the portable audio player.

FROM AUDIO PLAYER: Connect the portable audio player to the audio system.

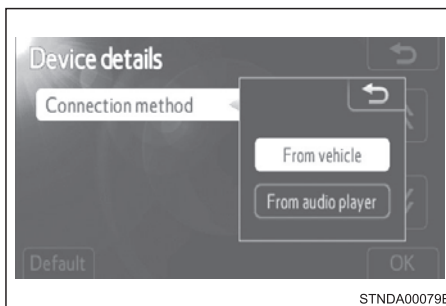

Selecting the Bluetooth® phone

If multiple Bluetooth® devices are registered, follow the procedure below to select the Bluetooth® device to be used. You may only use one device at a time.

1. Touch CONNECT TELEPHONE on the BLUETOOTH* SETTINGS screen.
2. Touch the device to connect.

ADD NEW: Registering a Bluetooth® device, refer to page 233.

The selection indicator is displayed on left side of the selected device name.

The Bluetooth® mark is displayed when you connect the device.



Selecting the audio player

If multiple Bluetooth® devices are registered, follow the procedure below to select the Bluetooth® device to be used. You may only use one device at a time.

1. Touch CONNECT AUDIO PLAYER on the BLUETOOTH SETTINGS screen.
2. Touch the device to connect.

ADD NEW: Registering a Bluetooth® device, refer to page 233.

The selection indicator is displayed on left side of the selected device name.

The Bluetooth® mark is displayed when you connected the device.

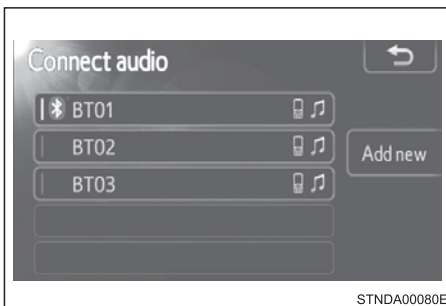

*: Bluetooth is a registered trademark of Bluetooth SIG, Inc.

Detailed Bluetooth® settings

You can confirm and change the detailed Bluetooth® settings.

1. Touch DETAILED BLUETOOTH* SETTINGS on the BLUETOOTH* SETTINGS screen.
2. The following screen is displayed:
 - a. Change Bluetooth® power on / off
You can change Bluetooth® function to ON or OFF.
 - b. Display device name.
 - c. Change passcode, refer to page 237.
 - d. Display device address.
 - e. Display compatibility profile of the system.
 - f. Change displaying telephone status on / off.
You can set the system to show the status confirmation display when connecting telephone.
 - g. Change displaying audio player status on / off.
You can set the system to show the status confirmation display when connecting an audio player.
 - h. Restore default settings.
3. When you complete the settings, touch OK.

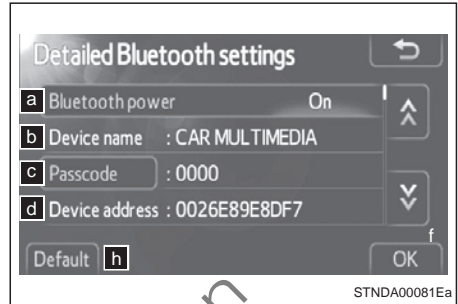

Editing the passcode

You can change the passcode that you use to register your Bluetooth® device in the system.

1. Touch PASSCODE on the DETAILED BLUETOOTH SETTINGS screen.
2. Input a passcode, and touch OK.



*: Bluetooth is a registered trademark of Bluetooth SIG, Inc.

Using the interior lights

Using the interior lights

INTERIOR LIGHTS OVERVIEW

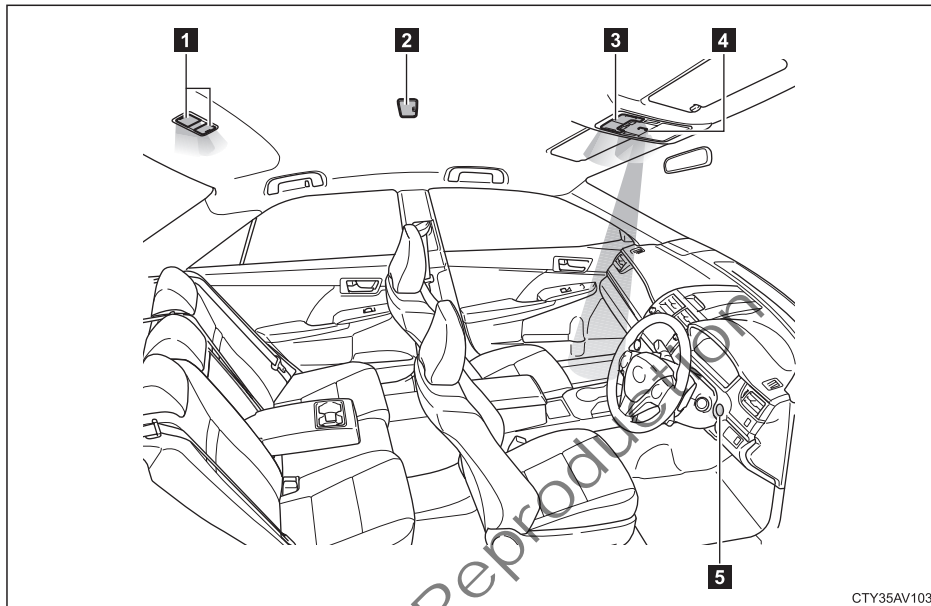

CTY35AV103

1	Interior / rear personal lights (vehicles with moon roof) refer to "Rear personal lights (vehicles with moon roof)" on page 239.
2	Interior light (vehicles without moon roof) refer to "Interior lights" on page 238.
3	Interior light (vehicles with moon roof) refer to "Interior lights" on page 238 / front personal lights refer to "Front personal lights" on page 239.
4	Shift lever light (when the tail lights are on – vehicles with moon roof).
5	POWER switch light

INTERIOR LIGHTS

Vehicles without moon roof –

To turn on the interior light, slide the switch.

The interior light switch has 3 positions:

1. Turns the lights on.
2. Turns the light on when the illuminated entry system operates, refer to "Illuminated entry system" on page 240.
3. Turns the lights off.

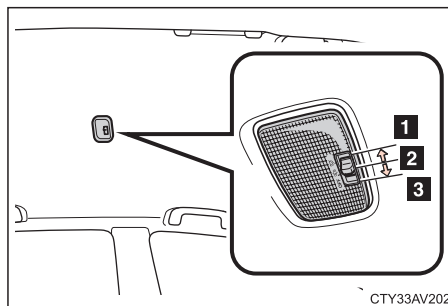

CTY33AV202

Using the interior lights

Vehicles with moon roof—

To turn on the interior light and rear personal lights, press the switch.

1. Turns the lights on / off when the illuminated entry system operates, refer to "Illuminated entry system" on page 240.
2. Turns the lights on / off.

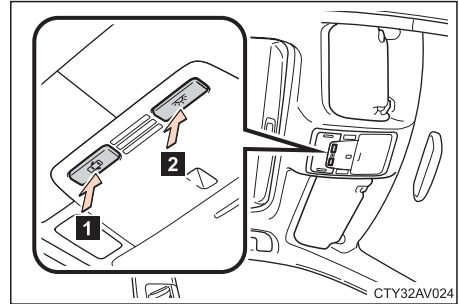
**PERSONAL LIGHTS****Front personal lights**

Press to turn the personal lights on / off.

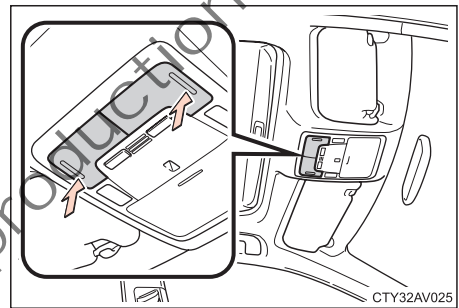
**Rear personal lights
(vehicles with moon roof)**

Press to turn the personal lights on / off.

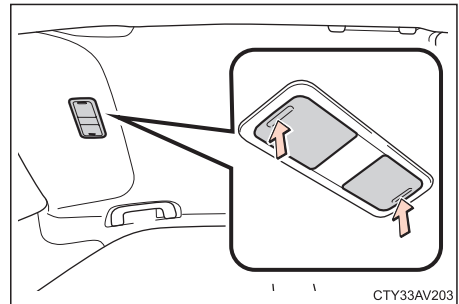

Using the interior lights

ILLUMINATED ENTRY SYSTEM

The lights automatically turn on / off according to the POWER switch mode, the presence of the electronic key, whether the doors are locked / unlocked, and whether the doors are open / closed.

When any of the doors are unlocked or in the presence of the electronic key, the lights will come on and remain on for about 15 seconds before fading out.

After all the doors are closed, the lights remain on for about 15 seconds before fading out.

If all the doors are closed and the POWER switch is turned to ACCESSORY or ON mode, the lights will fade out.



NOTICE

If the interior lights and / or personal lights are left on when the POWER switch is turned off, the lights will go off automatically after 20 minutes.

Customisable features that can be modified

For further information refer to “Customisable features” on page 339.

Not for Reproduction

Using the storage features

Using the storage features

STORAGE FEATURES OVERVIEW

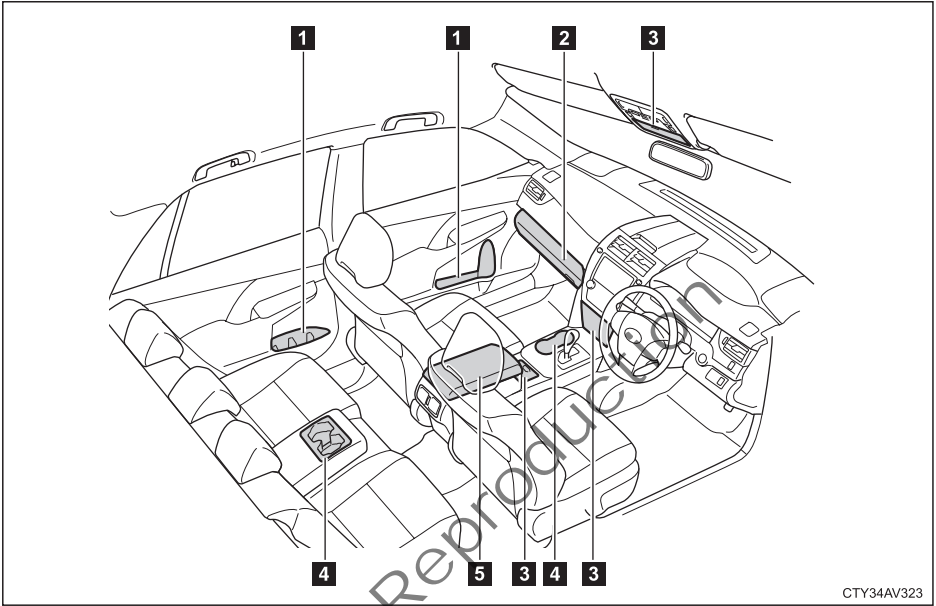

CTY34AV323

1	Bottle holders / door pockets	4	Cup holders
2	Glove box	5	Rear console box
3	Auxiliary boxes		

CAUTION

- Do not leave glasses in the storage spaces as they may be deformed by heat or cracked if they come into contact with other stored items.
- Do not leave lighters or spray cans in the storage spaces as they may explode. If they come into contact with other stored items, the lighter may catch fire or the spray can may release gas, causing a fire hazard.

Using the storage features

GLOVE BOX

To use the glove box

The glove box can be opened by pulling the lever and can be locked and unlocked by using the mechanical key.

1. Open.
2. Lock.
3. Unlock.

With the instrument panel lights on, the glove box light will come on when the glove box is open.

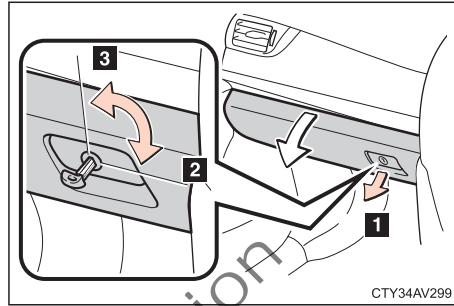

⚠ CAUTION

To reduce the chance of injury in case of an accident or a sudden stop, always keep the glove box door closed while driving.

AUXILIARY BOXES

Overhead auxiliary box –

Push the lid.

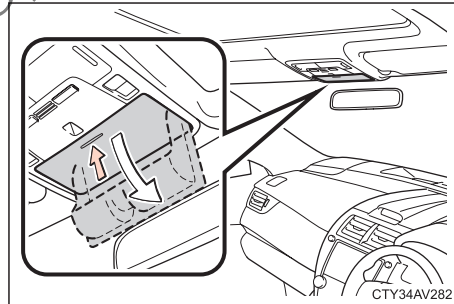

Instrument panel auxiliary box –

Push the lid.

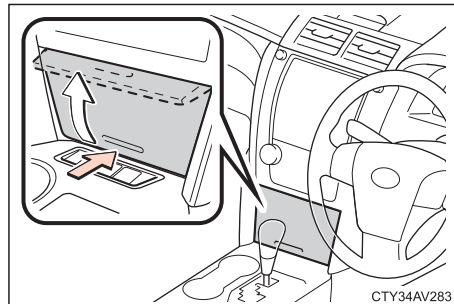

Using the storage features

Centre console auxiliary box—
Lift the lid.

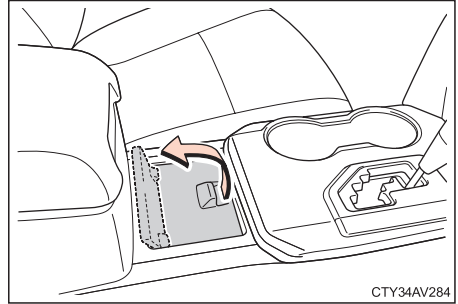

⚠ CAUTION

Caution while driving

Keep the auxiliary boxes closed. In the event of sudden braking, an injury may occur due to an occupant being struck by the items stored inside an open auxiliary box.

Items unsuitable for storing (overhead auxiliary box only)

Do not store items heavier than 0.2 kg. Doing so may cause the auxiliary box to open and the item inside may fall out, resulting in an accident.

REAR CONSOLE BOX

To open the console box, lift the lid while pulling up the lock release latch.

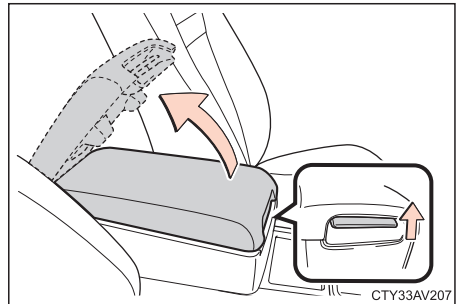

If desired, the console box lid can be slid forward to add to comfort. Pull up the lock release latch and pull forward.

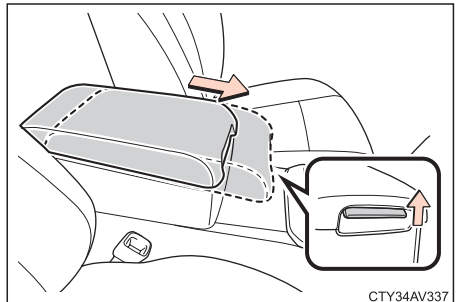

Using the storage features

The lid can also be opened from the forward most position.

! CAUTION

To reduce the chance of injury in case of an accident or a sudden stop, always keep the console box closed while driving.

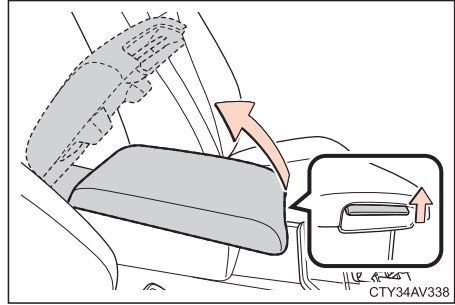

CUP HOLDERS

Front cup holders

The cup holder is designed for holding cups or drink cans securely.

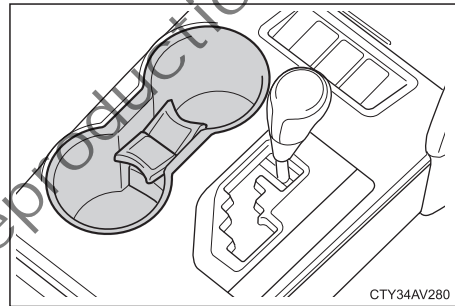

Cup holder insert—

The cup holder insert can be removed.

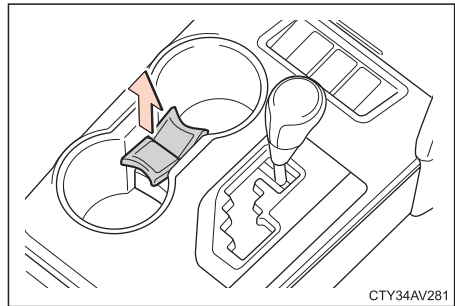

Using the storage features

Rear cup holders

The cup holder is designed for holding cups or drink cans securely. To use it, pull down the armrest.

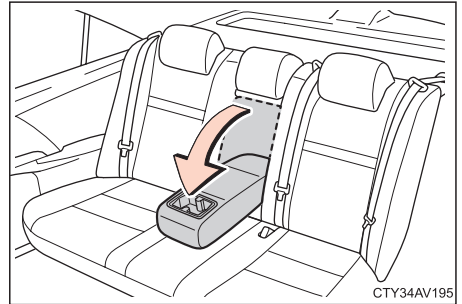
**CAUTION**

- Do not place anything else other than cups or drink cans in the cup holders, as such items may be thrown about the vehicle interior and possibly injure people in the vehicle during sudden braking or in an accident. If possible cover hot drinks to prevent burns.
- Do not lift the rear armrest upright when the cup holder is in use.

BOTTLE HOLDERS

Front—

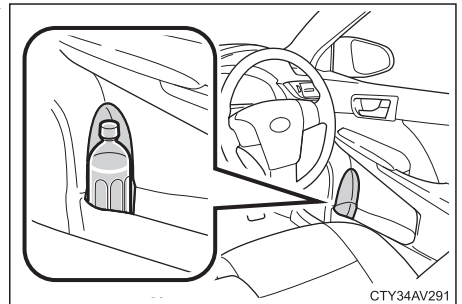

Rear—

INFORMATION

- Ensure that caps are fitted securely to bottles placed in the bottle holders.
- The bottle may not be able to be stored depending on its size or shape.



Using the storage features

CAUTION

Do not place anything other than bottles in the bottle holder, as such items may be thrown about in the compartment and possibly injure people in the vehicle during sudden braking or in an accident.

GROCERY BAG HOOKS

These hooks are designed to hang items such as grocery bags.

NOTICE

To prevent damage to the hooks, avoid hanging heavy loads on them.

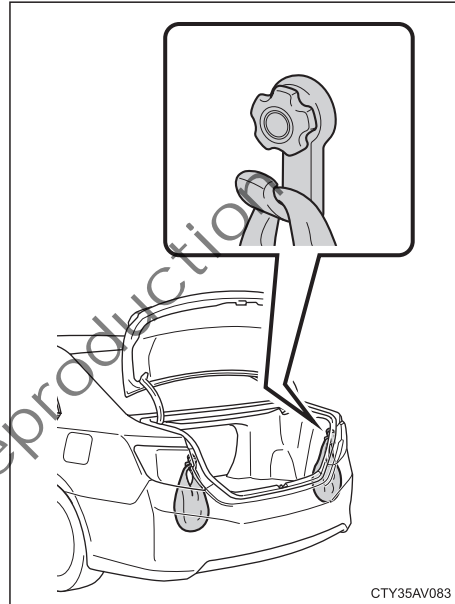

Other interior features

CLOCK

The clock is displayed when the POWER switch is in ACCESSORY or ON mode.

To set the clock

1. Adjusts the hours.
2. Adjusts the minutes.

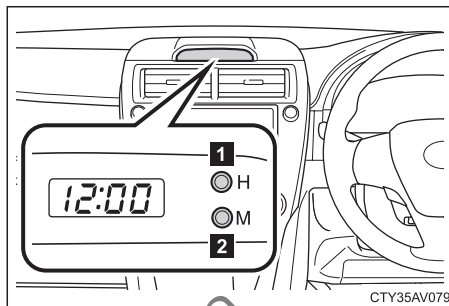

INFORMATION

When disconnecting and reconnecting the 12-volt auxiliary battery terminals the time display will automatically be set to 1:00.

POWER OUTLETS

The POWER switch must be in ACCESSORY or ON mode for the power outlets to be used.

Instrument panel –

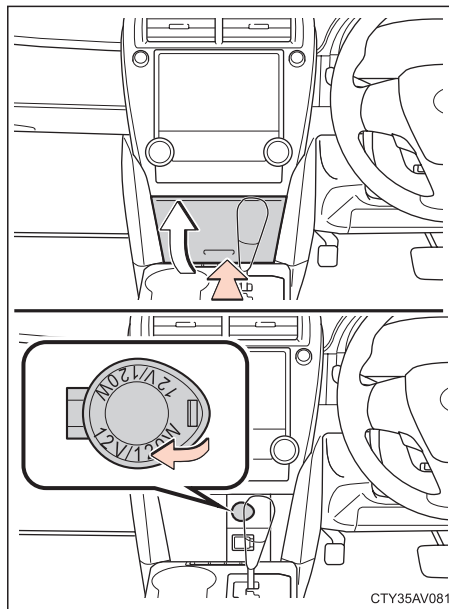

Other interior features

Centre console—

NOTICE

- To prevent the fuse from being blown, do not use accessories with a power rating of more than 12V / 10 A.
 - To prevent the 12-volt auxiliary battery from being discharged, do not use the power outlets longer than necessary when the hybrid system is not running.
 - Close the power outlet lid when the power outlet is not in use.
- Inserting anything other than an appropriate plug that fits the outlet, or allowing any liquid to get into the outlet may cause electrical failure or short circuits.

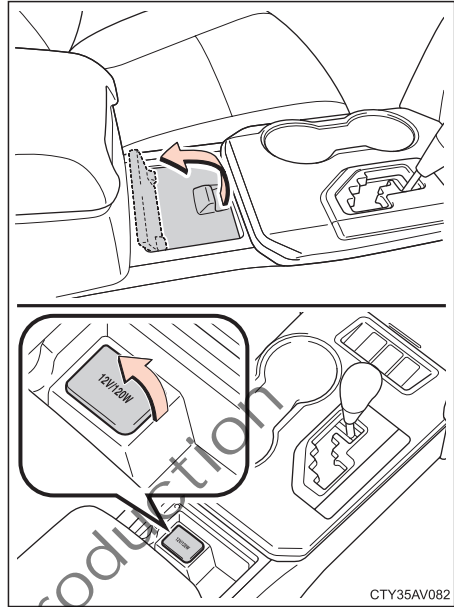

SUN VISORS

To set the visor in the lower position, flip it down.

To set the visor in the side position, flip it down, unhook, and swing it to the side.

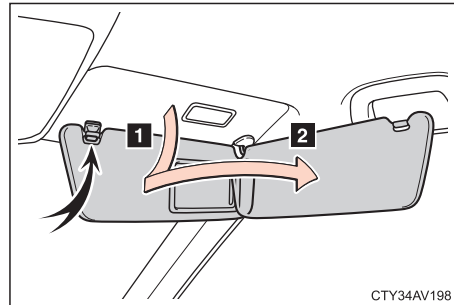

Other interior features

VANITY MIRRORS

To use the vanity mirror, swing down the sun visor and open the cover.

The vanity light (if fitted) comes on when you open the cover.

INFORMATION

To prevent 12-volt auxiliary battery discharge, the vanity lights (if fitted) will automatically turn off after 20 minutes when the hybrid system is not running.

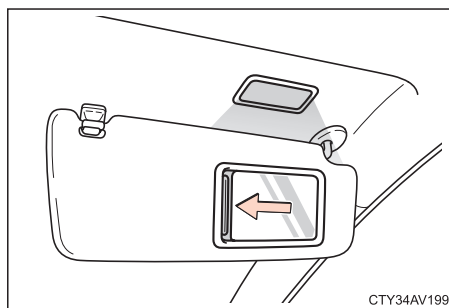

CTY34AV199

REAR ELECTRIC SUNSHADE

To raise the rear sunshade, press the switch shown in the illustration. To lower the shade, press the switch again.

The POWER switch must be in ON mode.

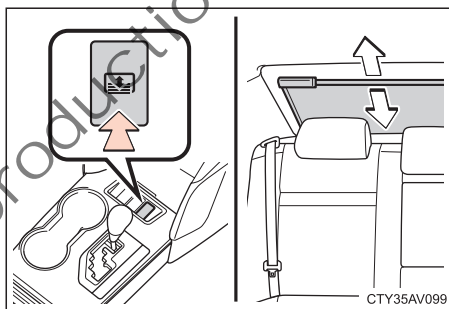

CTY35AV099

INFORMATION

- The rear sunshade can be used only when the POWER switch is in ON mode.
- The rear sunshade can be operated for approximately 1 minute after the POWER switch is pressed off.

Reverse operation feature

- To ensure adequate rear visibility, the rear sunshade automatically lowers when the shift lever is moved to R position.

However, the rear sunshade is raised again if any of the following occurs:

- The switch is pressed again
- The shift lever is moved to P position
- The shift lever is moved out of R, and the vehicle reaches a speed of 15 km/h
- The POWER switch is pressed off.

When the reverse operation feature does not work

- The reverse operation feature may not work under some conditions. In such cases, press the switch to extend / retract the rear sunshade.

Other interior features

⚠ CAUTION

- To avoid injuring your fingers on the screws, etc., do not touch the brackets fastening the shade.
- Do not put your fingers in the shade groove while the shade is operating to avoid getting them caught or injured by the runner.

⚠ NOTICE

- To maintain 12-volt auxiliary battery life, always operate the rear electric sunshade while the hybrid system is operating.
- The rear electric sunshade may fail or be damaged unless the following items are considered:
 - Do not overload the shade motor and other parts
 - Do not place anything where it may hinder the lowering/raising of the shade
 - Do not place items on the shade
 - Clean the shade groove if there is any foreign matter or dust
 - Do not operate the rear sunshade continuously for long periods of time

FLOOR MAT

Insert the retaining hooks (clips) into the floor mat eyelets.

⚠ NOTICE

Use only floor mats designed specifically for vehicles of the same model and model year as your vehicle. Fix them securely in place onto the carpet.

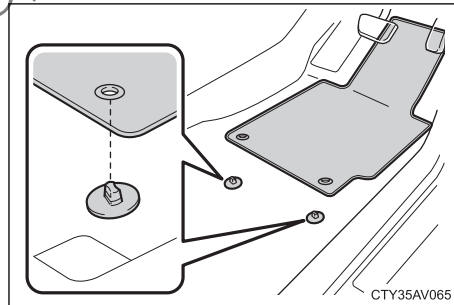

Turn the upper knob of each retaining hook (clip) to secure the floor mats in place.

*: Always align the Δ marks.

The shape of the retaining hooks (clips) may differ from that shown in the illustration.

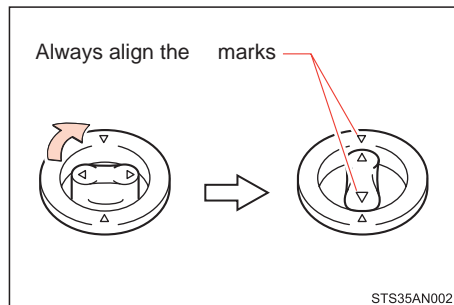

! CAUTION

Observe the following precautions, as failure to do so may cause the driver's floor mat to slip, possibly interfering with the pedals while driving. An unexpectedly high speed may result or it may become difficult to stop the vehicle, leading to a serious accident.

When installing the driver's floor mat

- Do not use floor mats designed for other models or different model year vehicles, even if they are Toyota Genuine floor mats.
- Only use floor mats designed for the driver's side.
- Always install the floor mat securely using the retaining hooks (clips) provided.
- Do not use two or more floor mats on top of each other.
- Do not place the floor mat bottom-side up or upside-down.

Before driving

- Check the floor mat is securely fixed in the correct place with all the provided retaining hooks (clips). Be especially careful to perform this check after cleaning the floor.
- With the hybrid system stopped and the shift lever in P position, fully depress each pedal to the floor to ensure it does not interfere with the floor mat.

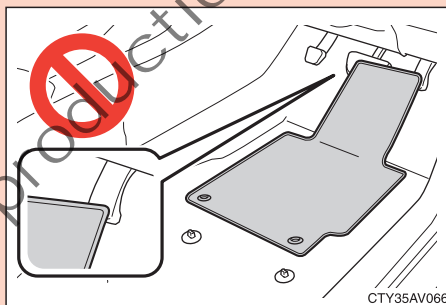
**ASSIST GRIPS**

An assist grip installed above the door can be used to support your body while sitting on the seat.

! NOTICE

To prevent damage do not hang heavy objects or place a heavy load on the assist grip.

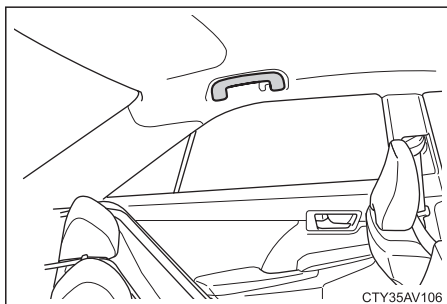
**! CAUTION**

Do not use the assist grip when getting in or out of the vehicle or rising from your seat.

Other interior features

COAT HOOKS

! CAUTION

Items that cannot be hung on the coat hook

Do not hang coat hangers or other hard or sharp objects on the hook. If the SRS curtain shield airbags deploy, these items may become projectiles, causing death or serious injury.

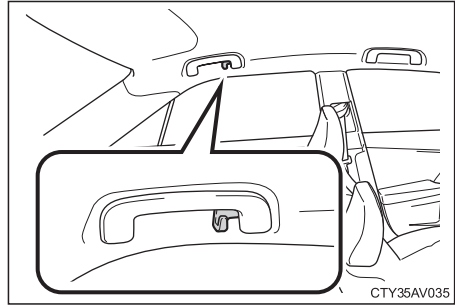

Not for Reproduction

MAINTENANCE AND CARE

Maintenance and care	254
CLEANING AND PROTECTING THE EXTERIOR	254
CLEANING AND PROTECTING THE INTERIOR	257
Maintenance requirements	259
MAINTENANCE REQUIREMENTS	259
DOES YOUR VEHICLE NEED REPAIRING?	260
Do-it-yourself maintenance	261
DO-IT-YOURSELF SERVICE PRECAUTIONS	261
BONNET	263
POSITIONING A FLOOR JACK	264
ENGINE COMPARTMENT OVERVIEW	266
ENGINE OIL	266
COOLANT	270
RADIATORS AND CONDENSER	272
BRAKE FLUID	272
WASHER FLUID	273
TYRES	274
WHEELS	278
AIR CONDITIONING FILTER	279
12-VOLT AUXILIARY BATTERY	280
CHECKING AND REPLACING FUSES	283
LIGHT BULBS	291
REPLACING THE REMOTE CONTROL TRANSMITTER BATTERY	303

Not for Reproduction

Maintenance and care

CLEANING AND PROTECTING THE EXTERIOR

⚠ CAUTION

When cleaning the windscreen (vehicles with rain-sensing windscreen wiper)

Set the wiper switch to off.

If the wiper switch is in AUTO, the wipers may operate unexpectedly in the following situations, which may result in hands being caught or other serious injuries and cause damage to the wiper blades.

- When the upper part of the windscreen (where the raindrop sensor is located) is touched by hand.
- When a wet rag or similar is held close to the raindrop sensor.
- If something bumps against the windscreen.
- If you directly touch the raindrop sensor body or if something bumps into the raindrop sensor.

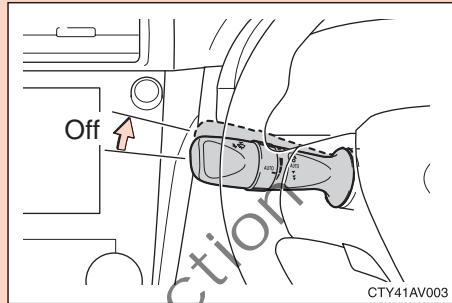

Exhaust pipe precautions

Exhaust gasses cause the exhaust pipe to become quite hot. When washing the vehicle, be careful not to touch the pipe until it has cooled sufficiently, as touching a hot exhaust pipe can cause burns.

⚠ NOTICE

When washing the vehicle

Do not apply water to the inside of the engine compartment. Doing so may damage the electrical components, etc.

Cleaning the exterior lights

- Wash carefully. Do not use organic substances or scrub with a hard brush. This may damage the surfaces of the lights.
- Do not apply wax on the surfaces of the lights. Wax may cause damage to the lenses.

Perform the following to protect the vehicle and maintain it in prime condition.

- Working from top to bottom, liberally apply water to the vehicle body, wheel-wells and underside of the vehicle to remove any dirt and dust.
- Wash the vehicle body using a sponge or soft cloth, such as a chamois.
- For hard-to-remove marks, use car wash soap and rinse thoroughly with water.
- Wipe away any water.
- Wax the vehicle when the waterproof coating deteriorates.
- If water does not bead on a clean surface, apply wax when the vehicle body is cool.

Automatic car washes

- Fold the mirrors before washing the vehicle. Start washing from the front of the vehicle. Make sure to extend the mirrors before driving.
- Brushes used in automatic car washes may scratch the vehicle surface and harm your vehicle's paint.
- Vehicles with a rear spoiler: In certain automatic car washes, the rear spoiler may interfere with machine operation. This may prevent the vehicle from being cleaned properly or result in damage to the rear spoiler.

High pressure car washes

- Do not allow the nozzles of the car wash to come within close proximity of the windows.
- Before washing the car, check the fuel filler door on your vehicle is closed properly.

NOTICE

When using a car wash, if the door handle is sprayed with a jet of water while the electronic key is within the detection range, the door may lock and unlock repeatedly. In that case, either:

- Place the electronic key in a location 2 metres or more away from the vehicle. (Take care to ensure the key is not stolen)
- Set the electronic key to battery-saving mode to disable the smart entry and start system, refer to "Electronic key battery-saving function" on page 24.

Aluminium wheels

- Remove any dirt immediately by using a neutral detergent. Do not use hard brushes or abrasive cleaners. Do not use strong or harsh chemical cleaners.
- Use the same mild detergent and wax as used on the paint.
- Do not use detergent on the wheels when they are hot, for example after driving for a long distance in hot weather.
- Wash detergent from the wheels immediately after cleaning.

Bumpers

- Do not scrub with abrasive cleaners. The bumper faces are soft.

Maintenance and care

Paintwork

- If the paint is chipped or scratched, have it repaired immediately.

NOTICE

Precaution regarding the blind spot monitor

If the paint on the rear bumper is chipped or scratched, the system may malfunction. If this occurs, consult your Toyota dealer.

NOTICE

To prevent paint deterioration and corrosion on the body and components (aluminium wheels, etc.)

- Wash the vehicle immediately in the following cases:
 - After driving near the sea coast
 - After driving on salted roads
 - If coal tar or tree sap is present on the paint surface
 - If dead insects, insect droppings or bird droppings are present on the paint surface
 - After driving in an area contaminated with soot, oily smoke, mine dust, iron powder or chemical substances
 - If the vehicle becomes heavily soiled with dust or mud
 - If liquids such as benzene and petrol are spilled on the paint surface
- To prevent the wheels from corroding when storing, remove any dirt and store in a place with low humidity.

CLEANING AND PROTECTING THE INTERIOR

CAUTION

- Be careful not to splash water or spill liquid on the floor. This may prevent the side airbags or side airbags and curtain shield airbags from activating correctly, resulting in death or serious injury.
- Do not wash the vehicle floor with water, or allow water to get onto the floor when cleaning the vehicle interior or exterior. Water may get into audio components or other electrical components above or under the floor carpet (or mat) and cause a malfunction; and it may cause vehicle body corrosion.
- Do not use polish wax or polish cleaner particularly on the instrument panel as it may reflect on the windscreen, obstructing the driver's view leading to an accident, resulting in death or serious injury.

The following procedures will help protect your vehicle's interior and keep it in top condition.

If you have any questions about the cleaning of your Toyota, your local Toyota dealer will be pleased to answer them.

Cleaning the vehicle interior

Remove dirt and dust using a vacuum cleaner. Wipe dirty surfaces with a cloth dampened with lukewarm water.

NOTICE

Cleaning detergents

Do not use the following types of detergent, as they may discolour the vehicle interior or cause streaks or damage to painted surfaces.

- Non-seat portions: Organic substances such as benzene or petrol, alkaline or acidic solutions, dye and bleach.
- Seats: Alkaline or acidic solutions, such as thinner, benzene, and alcohol.

Do not use polish wax or polish cleaner. The instrument panel or other interior part's painted surface may be damaged.

Cleaning the leather areas

- Remove dirt and dust using a vacuum cleaner.
- Wipe off any excess dirt and dust with a soft cloth dampened with diluted detergent. Use a diluted water solution of approximately 5% neutral wool detergent.
- Wring out any excess water from the cloth and thoroughly wipe off all remaining traces of detergent.
- Wipe the surface with a dry, soft cloth to remove any remaining moisture. Allow the leather to dry in a shaded and ventilated area.

Maintenance and care

Caring for leather areas–

- Toyota recommends cleaning the interior of the vehicle at least twice a year to maintain the quality of the vehicle's interior.

NOTICE

Preventing damage to leather surfaces

Observe the following precautions to avoid damage to and deterioration of leather surfaces.

- Remove any dust or dirt from leather surfaces immediately.
- Do not expose the vehicle to direct sunlight for extended periods of time. Park the vehicle in the shade, especially during summer.
- Do not place items made of vinyl, plastic, or containing wax on the upholstery, as they may stick to the leather surface if the vehicle interior heats up significantly.

Cleaning the synthetic leather areas

- Remove loose dirt using a vacuum cleaner.
- Apply a mild soap solution to the synthetic leather using a sponge or soft cloth.
- Allow the solution to soak in for a few minutes. Remove the dirt and wipe off the solution with a clean, damp cloth.

Shampooing the carpets

There are several commercial foaming-type cleaners available. Use a sponge or brush to apply the foam. Rub in overlapping circles. Do not use water. Wipe dirty surfaces and let them dry. Excellent results are obtained by keeping the carpet as dry as possible.

Seatbelts

Clean with mild soap and lukewarm water using a cloth or sponge. Also check the belts periodically for excessive wear, fraying or cuts.

NOTICE

Cleaning the inside of the rear window

- Be careful not to scratch or damage the heater wires or antenna.
- Do not use glass cleaner to clean the rear window, as this may cause damage to the rear window defogger heater wires or antenna.
Use a cloth dampened with lukewarm water to gently wipe the window clean. Wipe the window in strokes running parallel to the heater wires or antenna.

Maintenance requirements

MAINTENANCE REQUIREMENTS

To ensure safe and economical driving, day-to-day care and regular maintenance are essential.

Scheduled maintenance

Scheduled maintenance should be performed at specified intervals according to the maintenance schedule.

For full details of your maintenance schedule, refer to the "Warranty and Service Book".

Do-it-yourself maintenance

Many maintenance items are easy to do yourself if you have a little mechanical ability and a few basic automotive tools.

Note that some maintenance tasks require special tools and skills and are best performed by qualified technicians. Even if you are an experienced do-it-yourself mechanic, we recommend that repairs and maintenance be conducted by your Toyota dealer who will keep a record of maintenance on your vehicle. This record could be helpful should you ever require Warranty Service.

Regular maintenance will also aid:

- Good fuel economy
- Long vehicle life
- Driving enjoyment
- Safety
- Reliability
- Compliance with government regulations

Where to go for service?

It makes good sense to take your vehicle to your local Toyota dealer for service.

Toyota technicians are well-trained specialists. And they are receiving the latest service information through technical bulletins, service tips, and in-dealership training programs. They learn to work on Toyotas before they work on your vehicle, rather than while they are working on it. Doesn't that seem like the best way?

Your Toyota dealer has invested a lot of money in special Toyota tools and service equipment. It helps them to do the job better and at less cost.

Your Toyota dealer's service department will perform all of the scheduled maintenance on your vehicle reliably and economically.

Maintenance requirements

DOES YOUR VEHICLE NEED REPAIRING?

Be on the alert for changes in performance, sounds, and visual tip-offs that indicate service is needed. Some important symptoms are as follows:

- Engine missing, stumbling, or pinging.
- Appreciable loss of power.
- Strange engine noises.
- A leak under the vehicle. (However, water dripping from the air conditioning after use is normal.)
- Change in exhaust sound. (This may indicate a dangerous carbon monoxide leak. Drive with the windows open and have the exhaust system checked immediately.)
- Flat-looking tyre; excessive tyre squeal when cornering; uneven tyre wear.
- Vehicle pulls to one side when driving straight on a level road.
- Strange noises related to suspension movement.
- Loss of brake effectiveness; spongy feeling brake pedal; the pedal almost touches floor; vehicle pulls to one side when braking.
- Engine coolant temperature continually higher than normal.

If you notice any of these symptoms, take your vehicle to your Toyota dealer as soon as possible. It probably needs adjustment or repair.

CAUTION

If your vehicle is not properly maintained

- Do not continue driving with the vehicle unchecked. It could result in serious vehicle damage and serious injury or death to users.
- Improper maintenance could result in serious damage to the vehicle and possible serious injury or death.

Handling of the 12-volt auxiliary battery

12-volt auxiliary battery posts, terminals and related accessories contain lead and lead compounds which are known to cause brain damage. Wash your hands after handling.

Do-it-yourself maintenance

DO-IT-YOURSELF SERVICE PRECAUTIONS

If you perform maintenance by yourself, ensure to follow the correct procedures given in this section. You should be aware that incorrect or incomplete servicing may result in operating problems.

This section gives instructions only for those items that are relatively easy for an owner to perform. There are still a number of items that must be done by a qualified technician with special tools, refer to “Maintenance requirements” on page 259.

Utmost care should be taken when working on your vehicle to prevent accidental injury.

CAUTION

When working on the engine compartment

The engine compartment contains many mechanisms and fluids that may move suddenly, become hot, or become electrically energised. To avoid death or serious injury, observe the following precautions.

- Make sure that the POWER switch and the READY indicator are both off.
- Keep hands, clothing and tools away from the moving fans and engine drive belt.
- Immediately after driving, the engine compartment – the engine, power control unit, radiator, exhaust manifold and spark plug boots, etc. – will be hot. So be careful not to touch them. Oil, fluids and spark plugs may also be hot.
- If the engine is hot, do not remove the radiator cap or loosen the drain plugs to prevent burning yourself.
- Do not leave any combustible materials, such as paper or rags, in the engine compartment.
- Do not smoke, cause sparks or allow open flames around fuel or the battery. Their fumes are flammable.
- Be extremely cautious when working on the 12-volt auxiliary battery. It contains poisonous and corrosive sulphuric acid.
- Take care when filling the brake fluid reservoir because brake fluid can harm your hands or eyes. If fluid gets on your hands, flush the affected area with clean water immediately. If brake fluid gets in your eyes, flush your eyes with clean water immediately and seek medical assistance.

When working near the electric cooling fans or radiator grille

- Ensure the POWER switch is off if you work near the electric cooling fans or radiator grille. With the POWER switch on, the electric cooling fans will automatically start to run if the engine coolant temperature is high and / or the air conditioning is on.

Do-it-yourself maintenance

CAUTION

- Used engine oil contains potentially harmful contaminants which may cause skin disorders such as inflammation or skin cancer, so care should be taken to avoid prolonged and repeated contact with it. To remove used engine oil from your skin, wash thoroughly with soap and water.
- Do not leave used oil within the reach of children.
- Dispose of used oil and filter only in a safe and acceptable manner. Do not dispose of used oil and filter in household rubbish, in sewers or onto the ground. Call your dealer, a service station or local government for information concerning recycling or disposal.

When working under the vehicle

- Do not get under your vehicle with just the body jack supporting it. Always use automotive jack stands or other solid supports.
- Use eye protection whenever you work on or under your vehicle where you may be exposed to flying or falling material, fluid spray, etc.

NOTICE

- Remember that battery and ignition cables carry high currents or voltages. Be careful of accidentally causing a short circuit.
- Add only "Toyota Super Long Life Coolant" or similar high quality ethylene glycol based non-silicate, non-amine, non-nitrite, and non-borate coolant with long-life hybrid organic acid technology to fill the radiator. "Toyota Super Long Life Coolant" is a mixture of 50% coolant and 50% deionised water.
- If you spill some of the coolant, ensure to wash it off with water to prevent it from damaging the parts or paint.
- Do not allow dirt or anything else to fall through the spark plug holes.
- Do not prise the outer electrode of a spark plug against the centre electrode.
- Use only spark plugs of the specified type. Using other types will cause engine damage, loss of performance or radio noise.
- Do not reuse iridium-tipped spark plugs by cleaning or regapping.
- Do not overfill automatic transmission fluid or the transmission could be damaged.
- If you spill the fluid, ensure to wash it off with water to prevent it from damaging the parts or paint.
- Do not drive with the air cleaner filter removed, or excessive engine wear could result. Also backfiring could cause a fire in the engine compartment.
- Be careful not to scratch the glass surface with the wiper frame.
- When closing the engine bonnet, check to see that you have not forgotten any tools, rags, etc.

BONNET

To open the bonnet:

1. Pull the bonnet lock release lever. The bonnet will spring up slightly.

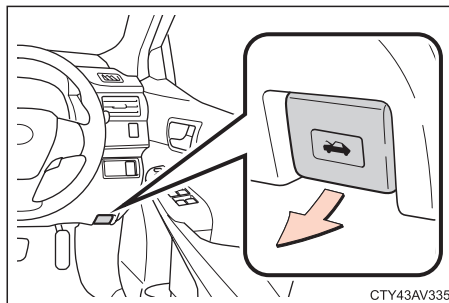

2. In front of the vehicle, lift the auxiliary catch lever and raise the bonnet.

- Before closing the bonnet, check to see that you have not forgotten any tools, rags, etc.
- To close the bonnet, lower it to about waist height and drop it to close it fully. Make sure it locks into place, if not, open it again and drop it from a slightly higher point.

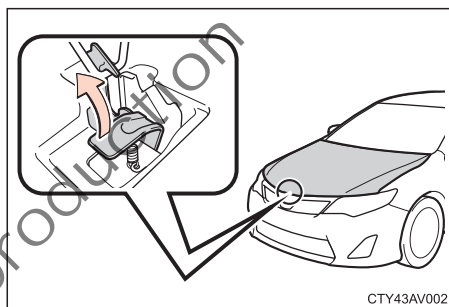

NOTICE

To avoid damaging the panel, avoid pushing the bonnet to close it.

CAUTION

Before driving, ensure the bonnet is closed and securely locked. Otherwise, the bonnet may open unexpectedly while driving and an accident may occur.

Do-it-yourself maintenance

POSITIONING A FLOOR JACK

When raising your vehicle with a trolley jack, position the jack correctly as shown.

Front–

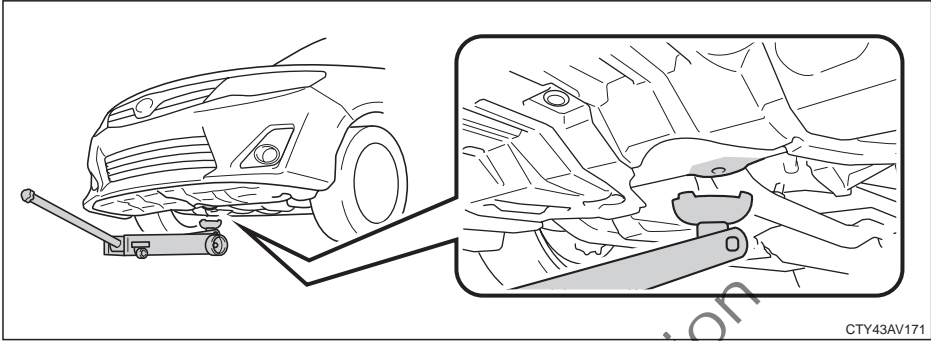

Rear–

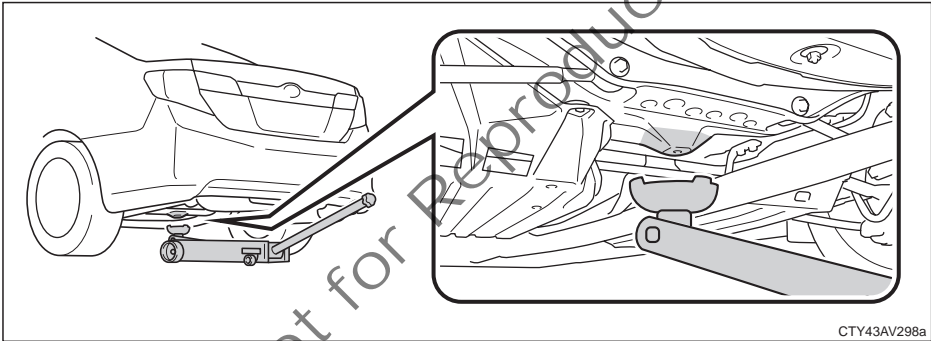

! CAUTION

Use only a trolley jack that complies with Mandatory Standards in force in relation to trolley jacks at the time of use. Use only a trolley jack that is rated strong enough to lift the vehicle.

 **CAUTION**

When using a trolley jack, observe the following to reduce the possibility of death or serious injury.

Follow the trolley jack instructions

- Use the hydraulic trolley jack on a hard level surface.
- Before commencing use, ensure that the trolley jack is free to roll during lifting and lowering.
- Do not put any part of your body under the vehicle supported by the jack. Personal injury may occur.
- Stop the vehicle on a level firm ground, firmly set the parking brake and put the transmission in P position.
- Do not start the hybrid system while the vehicle is supported by the floor jack.
- Chock the unlifted wheels.
- A trolley jack should only be used to raise and lower the vehicle. The vehicle should be supported by support stands, in accordance with the manufacturer's instructions.
- Ensure the jack is correctly set in the jack point. Raising the vehicle with the jack incorrectly positioned will damage the vehicle or may allow the vehicle to fall off the jack and cause personal injury.
- Do not raise the vehicle with someone in the vehicle.
- Ensure the load is centrally located on the head cap.
- When raising the vehicle, do not place any objects on top of or underneath the jack.

 **NOTICE**

Ensure the jack is placed correctly, or your vehicle may be damaged.

Do-it-yourself maintenance

ENGINE COMPARTMENT OVERVIEW

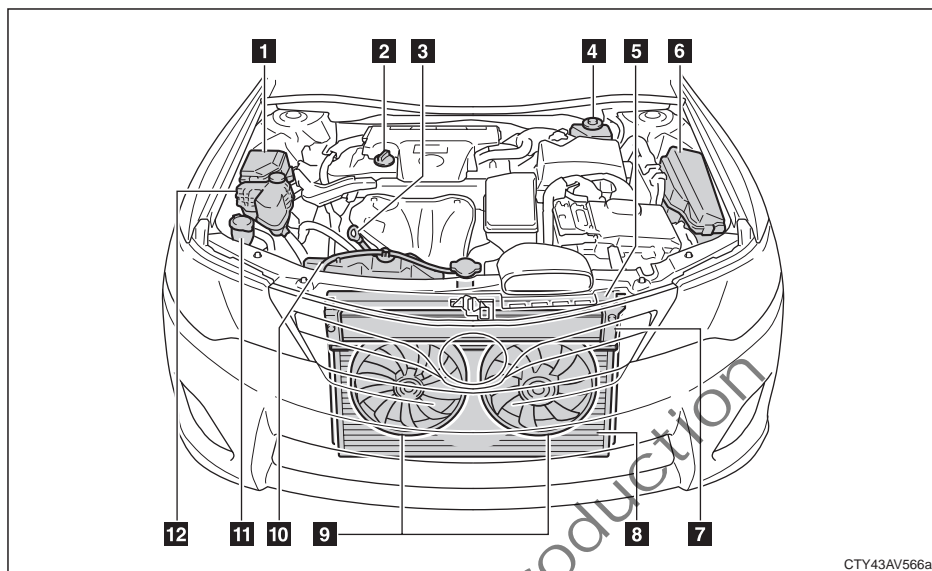

CTY43AV566a

1	Fuse box (hybrid system)	7	Power control unit coolant radiator
2	Engine oil filler cap	8	Condenser
3	Engine oil level dipstick	9	Electric cooling fans
4	Brake fluid reservoir	10	Engine coolant reservoir
5	Engine coolant radiator	11	Windscreen washer fluid tank
6	Fuse box	12	Power control unit coolant reservoir

ENGINE OIL

Importance of engine oil level check

One of the most important points in correct vehicle maintenance is to keep the engine oil at the optimum level so that oil function will not be impaired. Therefore, it is essential the oil level be checked regularly.

Toyota recommends the oil level be checked every time you refuel the vehicle.

NOTICE

Failure to check the oil level regularly could lead to serious engine damage due to insufficient oil.

Checking the engine oil level

With the engine at operating temperature and turned off, check the oil level on the dipstick.

1. To get a correct reading, the vehicle should be parked on level ground.
After turning off the hybrid system, wait a few minutes for the oil to drain back into the engine sump.

Do-it-yourself maintenance

2. Pull the dipstick out while holding a rag under the end and wipe it clean.

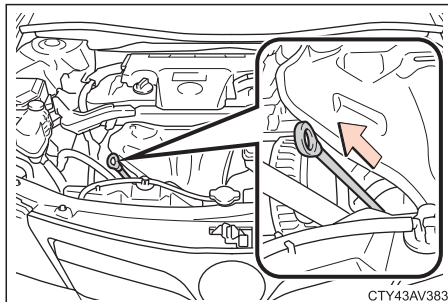

3. Reinsert the dipstick fully. The reading will be incorrect if it is not fully reinserted.
4. Pull the dipstick out while holding a rag under the end and inspect the oil level.
If the oil level is below or near the low level mark, add engine oil of the same type as already in the engine.

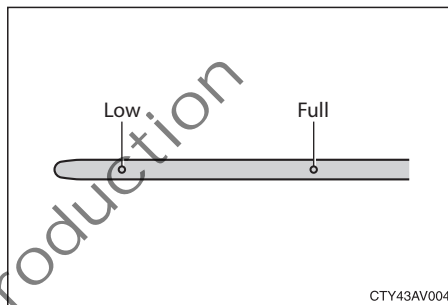

CAUTION

Be careful not to touch the hot exhaust manifold.

Adding engine oil

Remove the oil filler cap and add engine oil in small quantities at a time, checking the dipstick. We recommend that you use a funnel when adding oil.

The approximate quantity of oil needed to raise the level between low and full on the dipstick is 1.5 litres.

When the level is within the correct range, install the filler cap hand-tight.

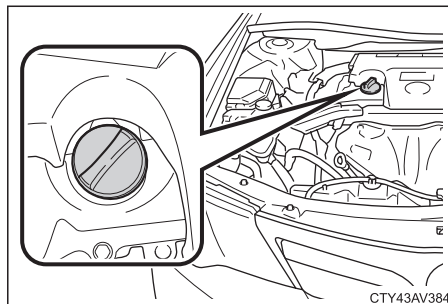

For the engine oil capacity refer to "Lubrication" on page 335.

NOTICE

- Be careful not to spill engine oil on the vehicle components.
- Avoid overfilling, or the engine could be damaged.
- Check the oil level on the dipstick once again after adding the oil.

Do-it-yourself maintenance

! CAUTION

Used engine oil

- Used engine oil contains potentially harmful contaminants which may cause skin disorders such as inflammation and skin cancer, so care should be taken to avoid prolonged and repeated contact. To remove used engine oil from your skin, wash thoroughly with soap and water.
- Dispose of used oil and filters only in a safe and acceptable manner. Do not dispose of used oil and filters in household waste, in sewers or onto the ground. Call your Toyota dealer, service station or auto parts store for information concerning recycling or disposal.
- Do not leave used engine oil within the reach of children.

Engine oil selection

Toyota Genuine Motor Oil is used in your Toyota vehicle. Use Toyota approved Toyota Genuine Motor Oil or equivalent to satisfy the following grade and viscosity.

Oil grade—

- 0W-20, 5W-20, 5W-30 and 10W-30
API grade SL Energy-Conserving, SM Energy-Conserving, SN Resource-Conserving or ILSAC multigrade engine oil
- 15W-40 and 20W-50
API grade SL, SM or SN multigrade engine oil

Recommended viscosity (SAE)—

If you use SAE 10W-30 or a higher viscosity engine oil in extremely low temperatures, the engine may become difficult to start, so SAE 5W-30 or lower viscosity engine oil is recommended.

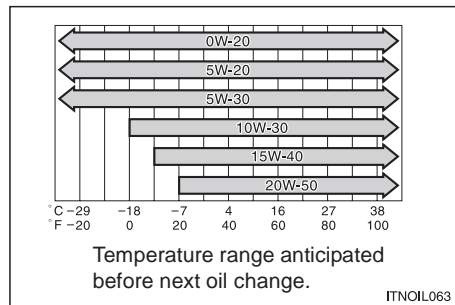

Oil viscosity explained (using 0W-20 as an example)—

- The 0W in 0W-20 indicates the characteristic of the oil which allows cold startability. Oils with a lower value before the W allow for easier starting of the engine in cold weather.
- The 20 in 0W-20 indicates the viscosity characteristic of the oil when the oil is at high temperature. An oil with a higher viscosity (one with a higher value) may be better suited if the vehicle is operated at high speeds, or under extreme load conditions.

Oil identification marks

Either or both API registered marks are added to some oil containers to help you select the oil you should use.

1. The API Service Symbol is located anywhere on the outside of the container.

- The top portion of the label shows the oil quality designations by API (American Petroleum Institute) such as SN.
- The centre portion of the label shows the SAE viscosity grade such as SAE 0W-20.
- Resource-Conserving shown in the lower portion indicates the oil has fuel saving and environmental protection capabilities.

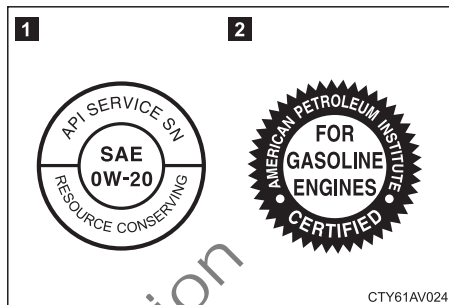

2. The ILSAC (International Lubricant Standardisation and Approval Committee) Certification Mark is displayed on the front of the container.

To ensure excellent lubrication performance for your engine, Toyota Genuine Motor Oil is available which has been specifically tested and approved for all Toyota engines.

Please contact your Toyota dealer for further details about Toyota Genuine Motor Oil.

Facts about engine oil consumption

Functions of engine oil–

Engine oil has the primary functions of lubricating and cooling the inside of the engine, and plays a major role in maintaining the engine in correct working order.

Engine oil consumption

It is normal that an engine should consume some engine oil during normal engine operation. The causes of oil consumption in a normal engine are as follows.

- Oil is used to lubricate pistons, piston rings and cylinders. A thin film of oil is left on the cylinder wall when a piston moves downwards in the cylinder. High negative pressure generated when the vehicle is decelerating sucks some of this oil into the combustion chamber. This oil as well as some part of the oil film left on the cylinder wall is burned by the high temperature combustion gases during the combustion process.
- Oil is also used to lubricate the stems of the intake valves. Some of this oil is sucked into the combustion chamber together with the intake air and is burned along with the fuel. High temperature exhaust gases also burn the oil used to lubricate the exhaust valve stems.

The amount of engine oil consumed depends on the viscosity of the oil, the quality of the oil and the conditions the vehicle is driven under.

More oil is consumed by high-speed driving and frequent acceleration and deceleration.

Do-it-yourself maintenance

A new engine consumes more oil since its pistons, piston rings and cylinder walls have not become conditioned.

- Oil consumption: Max. 1.0 L per 1000 km (1.1 qt., 0.9 Imp. qt.)

When judging the amount of oil consumption, note the oil may become diluted and make it difficult to judge the true level accurately.

As an example, if a vehicle is used for repeated short trips, and consumes a normal amount of oil, the dipstick may not show any drop in the oil level at all, even after 1000 km or more. This is because the oil is gradually becoming diluted with fuel or moisture, making it appear the oil level has not changed.

The diluting ingredients evaporate out when the vehicle is then driven at high speeds, as on an expressway, making it appear that oil is excessively consumed after driving at high speeds.

Importance of engine oil level check

One of the most important points in correct vehicle maintenance is to keep the engine oil at the optimum level so that oil function will not be impaired. Therefore, it is essential the oil level be checked regularly. Toyota recommends the oil level be checked every time you refuel the vehicle.

NOTICE

Failure to check the oil level regularly could lead to serious engine trouble due to insufficient oil.

COOLANT

Checking the engine coolant level

Look at the see-through engine coolant reservoir when the engine is cold.

1. Reservoir cap
2. FULL line
3. LOW line

- The coolant level is satisfactory if it is between the FULL and LOW lines on the reservoir when the engine is cold.
- The coolant level in the reservoir will vary with engine temperature. However, if the level is on or below the LOW line, add coolant. Bring the level up to the FULL line.

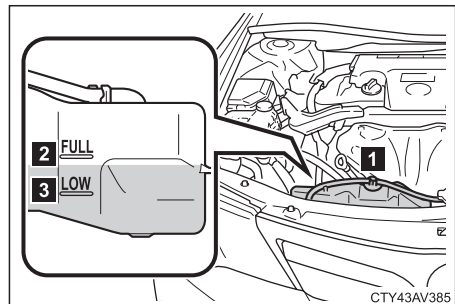

Checking the power control unit coolant level

Look at the see-through power control unit coolant reservoir when the engine is cold.

1. Reservoir cap
 2. FULL line
 3. LOW line
- The coolant level is satisfactory if it is between the FULL and LOW lines on the reservoir when the engine is cold.
 - The coolant level in the reservoir will vary with engine temperature. However, if the level is on or below the LOW line, add coolant. Bring the level up to the FULL line.

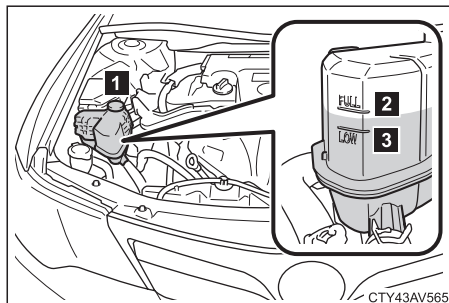

If the coolant levels drop within a short time after replenishing, there may be a leak in the system. Visually check the radiator, hoses, engine / power control unit coolant filler cap, radiator cap and drain cock and water pump.

If you can find no leak, have your Toyota dealer test the cap pressure and check for leaks in the cooling system.

CAUTION

When the hybrid system is hot

Do not remove the engine / power control unit coolant reservoir caps. The cooling system may be under pressure and may spray hot coolant if the cap is removed, causing serious injuries, such as burns.

Coolant type selection

Use of incorrect coolants may damage your engine cooling system.

Only use Toyota Super Long Life Coolant or similar high quality ethylene glycol based non-silicate, non-amine, non-nitrite, and non-borate coolant with long-life hybrid organic acid technology. (Coolant with long-life hybrid organic acid technology is a combination of low phosphates and organic acids.)

Toyota Super Long Life Coolant is a mixture of 50% coolant and 50% deionised water. This coolant provides protection down to about -35°C (-31°F).

Contact your Toyota dealer for further details.

NOTICE

- Do not use plain water alone.
- Coolant is neither plain water nor straight antifreeze. The correct mixture of water and antifreeze must be used to provide correct lubrication, corrosion protection and cooling.
- If you spill the coolant, wash it off with water immediately to prevent it from damaging parts or paint.

Do-it-yourself maintenance

RADIATORS AND CONDENSER

Check the radiators and condenser and clear away any foreign objects such as leaves, etc. If the radiator or the condenser is extremely dirty or you are not sure of their condition, take your vehicle to a Toyota dealer.

⚠ CAUTION

To prevent burning yourself, be careful not to touch the radiators or condenser when the engine is hot.

⚠ NOTICE

To prevent damage to the radiator and condenser, do not perform the work by yourself.

BRAKE FLUID

Checking the brake fluid level

To check the fluid level, simply look at the see-through reservoir. Refer to “Engine compartment overview” on page 266 for the location of the brake fluid reservoir. The level should be between the MAX and MIN lines on the reservoir.

It is normal for the brake fluid level to go down slightly as the brake pads wear. So ensure to keep the reservoir filled.

If the reservoir needs frequent refilling, it may indicate a serious mechanical problem.

If the level is low, add SAE J1703 or FMVSS No. 116 DOT 3 brake fluid to the brake reservoir. Remove and replace the reservoir cover by hand. Fill the brake fluid to the dotted line. This brings the fluid to the correct level when you put the cover back on.

Use only newly opened brake fluid. Once opened, brake fluid absorbs moisture from the air, and excess moisture can cause a dangerous loss of braking.

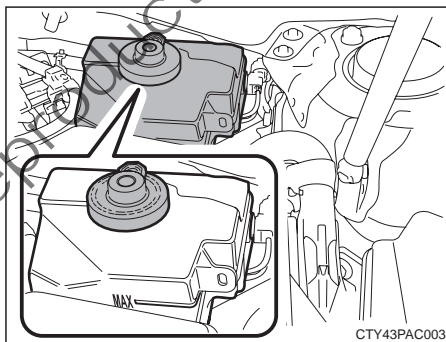

⚠ CAUTION

Take care when filling the reservoir because brake fluid can harm your eyes and damage painted surfaces. If fluid gets in your eyes, flush your eyes with clean water, and seek medical assistance.

⚠ NOTICE

If fluid is spilled, wash it off with water immediately to prevent damage to parts or paint.

WASHER FLUID

If the windscreen washers do not operate, the windscreen washer fluid tank may be empty. Refer to “Engine compartment overview” on page 266 for tank location.

Checking fluid level (without fluid gauge)

Remove the washer fluid tank cap and visually check the fluid level. If washer fluid is not visible, add fluid until the washer fluid fills the tank neck.

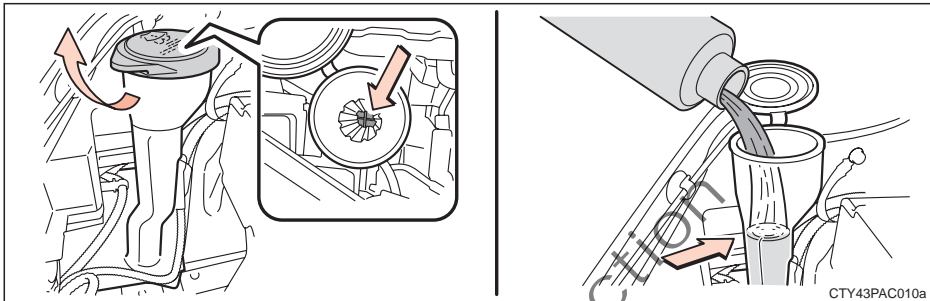

CTY43PAC010a

Checking fluid level (with fluid gauge)

1. Open the washer reservoir cap, pull out the fluid gauge and check the fluid level.
2. Check the fluid level by observing the liquid-covered holes on the fluid gauge.

If the level is below the second hole from the end of the gauge (the LOW mark) add washer fluid.

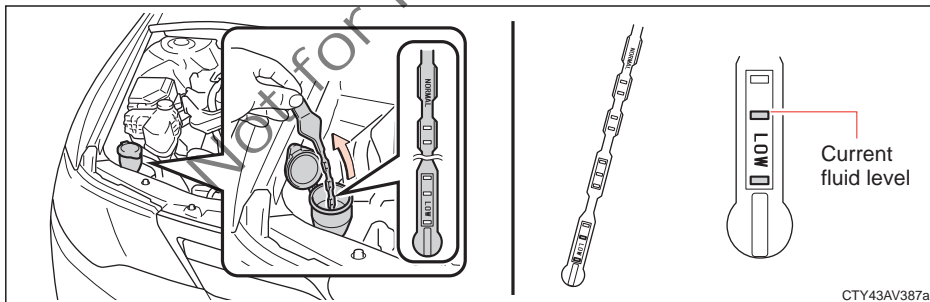

CTY43AV387a

⚠ CAUTION

Do not add washer fluid when the engine is hot or running as washer fluid contains alcohol and may catch fire if spilled on the hybrid system, etc.

Do-it-yourself maintenance

NOTICE

Do not overfill

Do not use any fluid other than washer fluid

Do not use soapy water or engine antifreeze instead of washer fluid. Doing so may cause streaking or damage the vehicle's painted surfaces.

Diluting washer fluid

Dilute washer fluid with water as necessary. Refer to the freezing temperatures listed on the label of the washer fluid bottle.

TYRES

Checking the tyre inflation pressure

Keep your tyre inflation pressures at the correct level.

The recommended cold tyre inflation pressures and tyre sizes is printed on the tyre placard located on the driver's body pillar. Also refer to "Tyres and wheels" on page 338.

You should check the tyre inflation pressure every two weeks, or at least once a month. And do not forget the spare!

Incorrect tyre inflation pressure may waste fuel, reduce the comfort of driving, reduce tyre life and make your vehicle less safe to drive.

The following instructions for checking tyre inflation pressure should be observed.

- The pressure should be checked only when the tyres are cold. If your vehicle has been parked for at least 3 hours and has not been driven for more than 1.5 km since, you will get an accurate cold tyre inflation pressure reading.
- Always use a tyre pressure gauge. The appearance of a tyre can be misleading. Tyres that are only slightly over or under inflated can degrade ride and handling.
- Do not bleed or reduce tyre inflation pressure after driving. It is normal for the tyre inflation pressure to be higher after driving.
- Reinstall the tyre valve caps. Without the valve caps, dirt or moisture could get into the valve core and cause air leakage. If the caps have been lost, have new ones put on as soon as possible.

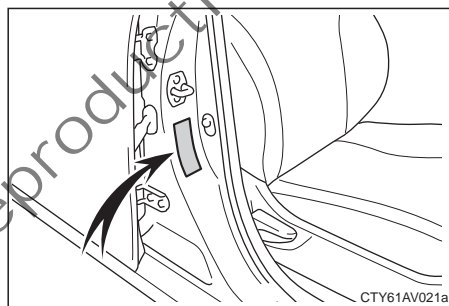

 **CAUTION**

- Keep your tyres inflated in accordance with the vehicle's specifications. Otherwise, death or serious injuries may result.
- Under inflation can result in:
 - Possibility of blowouts from an overheated tyre
 - Poor sealing of the tyre bead
 - Wheel deformation and/or tyre separation
 - Poor handling
 - Increased possibility of tyre damage from road hazards
 - Excessive wearing of tyres
 - Uneven wearing of tyres.
- Over inflation of tyres can result in:
 - Poor handling
 - Excessive wearing of tyres
 - Uneven wearing of tyres
 - Increased possibility of tyre damage from road hazards.

 **NOTICE****If tyre inflation pressure becomes low while driving**

Do not continue driving as your tyres and/or wheels may be ruined.

Driving on rough roads

Take particular care when driving on roads with loose surfaces or potholes.

These conditions may cause losses in tyre inflation pressure, reducing the cushioning ability of the tyres. In addition, driving on rough roads may cause damage to the tyres themselves, as well as the vehicle's wheels and body.

Do-it-yourself maintenance

Checking your tyres

The tyres on your Toyota have built-in tread wear indicators to help you know when the tyres need replacement.

The location of tread wear indicators is shown by the TWI or Δ marks, etc., moulded on the sidewall of each tyre as shown.

1. New tread.
2. Tread-wear indicator
3. Worn tread

When the tread depth wears to 1.6 mm or less, the indicators will appear. If you can see the indicators in two or more adjacent grooves, the tyre should be replaced.

The lower the tread, the higher the risk of skidding.

The effectiveness of snow tyres is lost if the tread wears down below 4 mm.

If you have tyre damage such as cuts, splits, cracks deep enough to expose the fabric, or bulges indicating internal damage, the tyre should be replaced.

If a tyre often goes flat or cannot be correctly repaired due to the size or location of a cut or other damage, it should be replaced. If you are not sure, consult with your Toyota dealer.

If air loss occurs while driving, do not continue driving. Driving even a short distance can damage a tyre beyond repair.

Tyres deteriorate with age even if they have never or seldom been used.

Any tyres which are over 6 years old must be checked by a qualified technician even if damage is not obvious. This applies also to the spare tyre and tyres stored for future use.

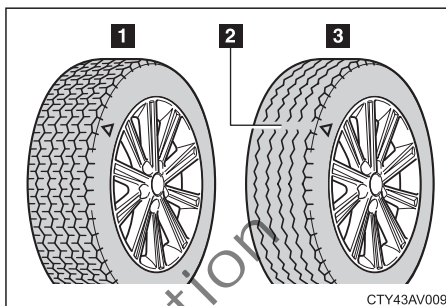

CTY43AV009

Replacing your tyres

! CAUTION

Observe the following instructions. Otherwise, an accident may occur resulting in death or serious injuries.

- Do not mix radial, bias belted, or bias-ply tyres on your vehicle, as this may cause dangerous handling characteristics resulting in loss of control.
- Do not use tyres other than the manufacturer's recommended size, as this may cause dangerous handling characteristics resulting in loss of control.
- Do not mix tyres of different makes, models or tread patterns, and do not mix tyres of remarkably different tread wear. This may cause dangerous handling characteristics resulting in loss of control.

When replacing a tyre, use a tyre of the same size and construction, and the same or greater load capacity as the originally installed tyres.

Using any other size or type of tyre may seriously affect handling, ride, speedometer / odometer calibration, ground clearance, and clearance between the body and tyres or snow chains.

Never use second-hand tyres on your Toyota. Using tyres whose previous history is unknown is a risk.

Toyota recommends all four tyres, or at least both front or rear tyres be replaced at a time as a set.

Refer to "If you have a flat tyre" on page 312 for tyre change procedure.

When a tyre is replaced, the wheel should always be balanced.

An unbalanced wheel may affect vehicle handling and tyre life. Wheels can get out of balance with regular use and should therefore be balanced occasionally.

When replacing a tubeless tyre, the air valve should also be replaced with a new one.

Rotating tyres

To equalise tyre wear and help extend tyre life, Toyota recommends that you rotate your tyres approximately every 10000 km. However, the most appropriate timing for tyre rotation may vary according to your driving habits and road surface conditions.

Refer to "If you have a flat tyre" on page 312 for tyre change procedure.

When rotating tyres, check for uneven wear and damage. Abnormal wear is usually caused by incorrect tyre pressure, incorrect wheel alignment, out-of-balance wheels or severe braking.

Vehicles with a spare tyre of a different type to the installed tyres–

- Rotate the tyres in the order shown.

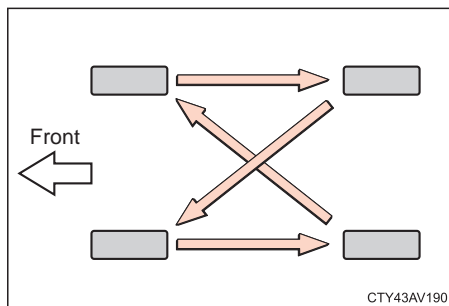

Vehicles with a spare tyre of the same type as the installed tyres–

- Rotate the tyres in the order shown.

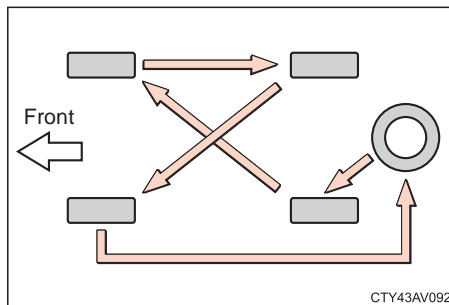

Do-it-yourself maintenance

WHEELS

When to replace your wheels

If you have wheel damage such as bending, cracks or heavy corrosion, the wheel should be replaced.

If you fail to replace a damaged wheel, the tyre may slip off the wheel or cause loss of handling control.

Refer to “If you have a flat tyre” on page 312 for tyre change procedure.

Wheel selection

When replacing wheels, care should be taken to ensure the wheels are replaced by ones with the same load capacity, diameter, rim width and offset.

Correct replacement wheels are available at your Toyota dealer.

A wheel of a different size or type may adversely affect handling, wheel and bearing life, brake cooling, speedometer/odometer calibration, stopping ability, headlight aim, bumper height, vehicle ground clearance, and tyre or snow chain clearance to the body and chassis.

Replacement with used wheels is not recommended as they may have been subjected to rough treatment or high mileage and could fail without warning. Also, bent wheels which have been straightened may have structural damage and therefore should not be used. Never use an inner tube in a leaking wheel which is designed for a tubeless tyre.

CAUTION

Do not use wheels other than the manufacturer's recommended size, as this may cause dangerous handling characteristics resulting in loss of control. Otherwise, an accident may occur resulting in death or serious injuries.

Aluminium wheel precautions

- When installing aluminium wheels, check the wheel nuts are tight after driving your vehicle the first 1600 km.
- If you have rotated, repaired, or changed your tyres, check the wheel nuts are still tight after driving 1600 km.
- When using tyre chains, be careful not to damage the aluminium wheels.
- Use only Toyota wheel nuts and wrench designed for your aluminium wheels.
- When balancing your wheels, use only Toyota balance weights or equivalent and a plastic or rubber hammer.
- As with any wheel, periodically check your aluminium wheels for damage. If damaged, replace immediately.

AIR CONDITIONING FILTER

The air conditioning filter must be changed regularly to maintain air conditioning efficiency.

- Inspect and replace the air conditioning filter according to the maintenance schedule.
- In dusty areas or areas with heavy traffic flow, early replacement may be required.
- If air flow from the vents decreases dramatically, the filter may be clogged. Check the filter and replace if necessary.

Replacement

1. Press the POWER switch off.
2. Open the glove box and slide off the damper.
3. Push in each side of the glove box to disconnect the stops.
4. Pull out the glove box and disconnect the lower claws.
5. Remove the filter cover.

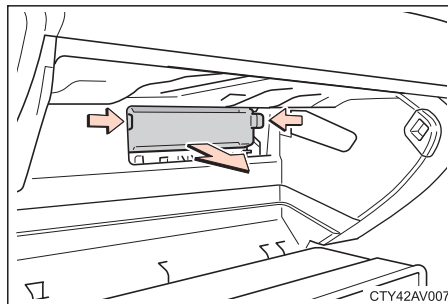
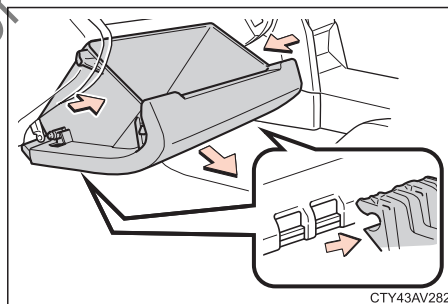
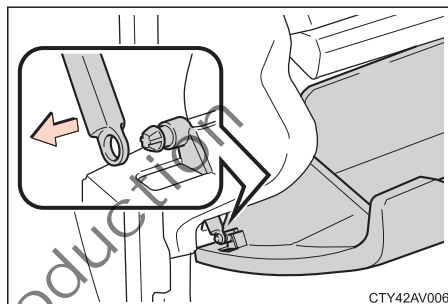

Do-it-yourself maintenance

6. Remove the air conditioning filter and replace it with a new one.

The UP marks shown on the filter should be pointing up.

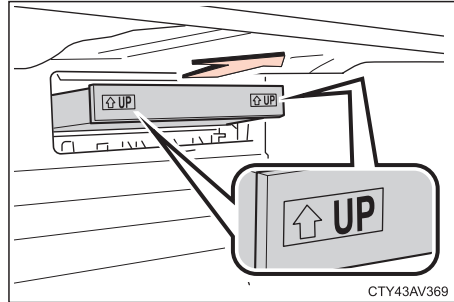

⚠ NOTICE

Make sure that a filter is always installed. Using the air conditioning system without a filter may cause damage to the system.

12-VOLT AUXILIARY BATTERY

Precautions

⚠ CAUTION

- Chemicals in the 12-volt auxiliary battery

The 12-volt auxiliary battery contains poisonous and corrosive sulphuric acid and may produce hydrogen gas which is flammable and explosive. To reduce the risk of death or serious injury, take the following precautions while working on or near the 12-volt auxiliary battery:

 - Do not cause sparks by touching the 12-volt auxiliary battery terminals with tools.
 - Do not smoke or light a match near the 12-volt auxiliary battery.
 - Avoid contact with eyes, skin and clothes.
 - Never inhale or swallow electrolyte.
 - Wear protective safety glasses when working near the 12-volt auxiliary battery.
 - Keep children away from the 12-volt auxiliary battery.
- Where to safely charge the 12-volt auxiliary battery

Always charge the 12-volt auxiliary battery in an open area. Do not charge the 12-volt auxiliary battery in a garage or closed room where there is insufficient ventilation.
- How to recharge the 12-volt auxiliary battery

Only perform a slow charge (5 A or less). The 12-volt auxiliary battery may explode if charged at a quicker rate.
- When replacing the 12-volt auxiliary battery
 - Use a 12-volt auxiliary battery designed for this vehicle. Failure to do so may cause gas (hydrogen) to enter the passenger compartment, causing a fire or explosion.
 - For replacement of the 12-volt auxiliary battery, contact your Toyota dealer.

CAUTION

- Emergency measures regarding electrolyte
 - If electrolyte gets in your eyes.
Flush your eyes with clean water for at least 15 minutes and get immediate medical attention. If possible, continue to apply water with a sponge or cloth while travelling to the nearest medical facility.
 - If electrolyte gets on your skin.
Wash the affected area thoroughly. If you feel pain or burning, get medical attention immediately.
 - If electrolyte gets on your clothes.
It can soak through clothing on to your skin. Immediately take off the clothing and follow the procedure above if necessary.
 - If you accidentally swallow electrolyte.
Drink a large quantity of water or milk. Get emergency medical attention immediately.

12-volt auxiliary battery location

The 12-volt auxiliary battery is located on the right-hand side of the luggage compartment.

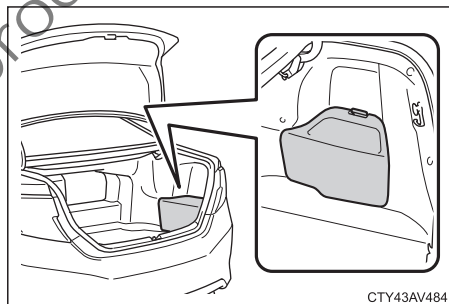

Accessing the 12-volt auxiliary battery

Remove the 12-volt auxiliary battery cover.

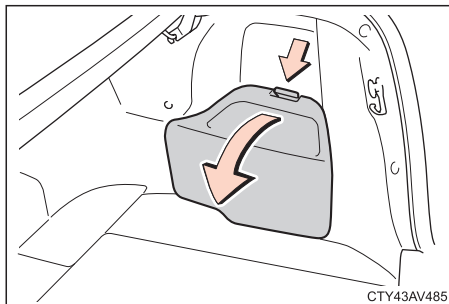

Do-it-yourself maintenance

Checking the 12-volt auxiliary battery exterior

Make sure that the 12-volt auxiliary battery terminals are not corroded and that there are no loose connections, cracks, or loose clamps.

1. Terminals.
2. Hold-down clamp.

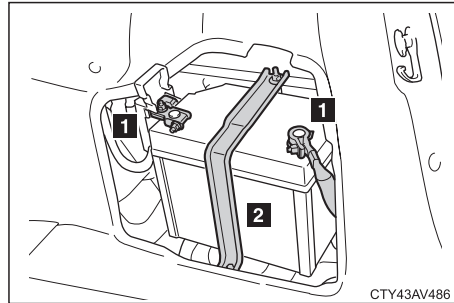

1. Check the vent hose for kinks or obstructions.
2. Ensure the vent hose passes through the grommet as shown.

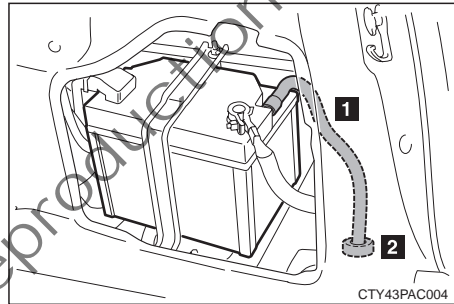

Before recharging

When recharging, the 12-volt auxiliary battery produces hydrogen gas which is flammable and explosive. Therefore, observe the following precautions before recharging:

- If recharging with the 12-volt auxiliary battery installed on the vehicle, be sure to disconnect the ground cable.
- Make sure the power switch on the charger is off when connecting and disconnecting the charger cables to the 12-volt auxiliary battery.

NOTICE

When recharging the 12-volt auxiliary battery Never recharge the 12-volt auxiliary battery while the hybrid system is operating.

Also, be sure all accessories are turned off.

After recharging / reconnecting the 12-volt auxiliary battery

- Unlocking the doors using the smart entry and start system may not be possible immediately after reconnecting the 12-volt auxiliary battery. If this happens, use the wireless remote control or the mechanical key to lock / unlock the doors.
- Start the hybrid system with the POWER switch in ACCESSORY mode. The hybrid system may not start with the POWER switch pressed off. However, the hybrid system will operate normally from the second attempt.
- The POWER switch mode is recorded by the vehicle. If the 12-volt auxiliary battery is reconnected, the vehicle will return the POWER switch mode to the status it was in before the 12-volt auxiliary battery was disconnected. Make sure to turn off the power before disconnecting the 12-volt auxiliary battery. Take extra care when connecting the 12-volt auxiliary battery if the POWER switch mode prior to discharge is unknown.

If the system will not start even after multiple attempts, contact your Toyota dealer.

CHECKING AND REPLACING FUSES

If any of the electrical components do not operate, a fuse may have blown. If this happens, check and replace the fuses as necessary.

Press the POWER switch off.

Engine compartment fuse block

- Push in the tabs and lift off the fusebox lid.

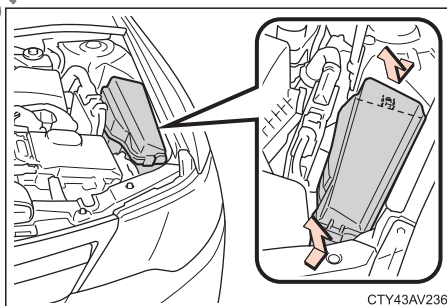
**Engine compartment fuse block (hybrid system)**

- Push in the tabs and lift off the fusebox lid.

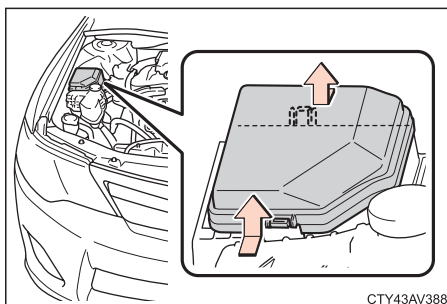

Do-it-yourself maintenance

Instrument panel fuse block

- Disconnect the four claws of the cover located under the instrument panel.

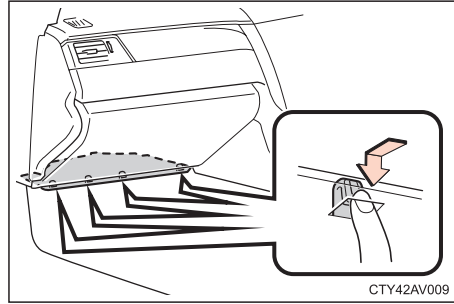

- Remove the cover by pulling it away from the instrument panel (toward the rear of the vehicle).

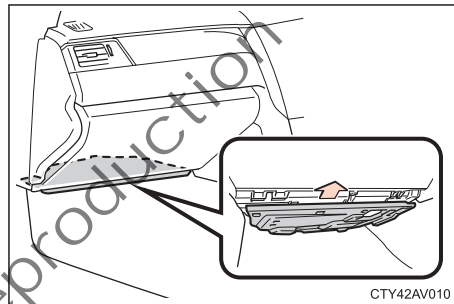

- Unplug the connector while depressing the lock release.

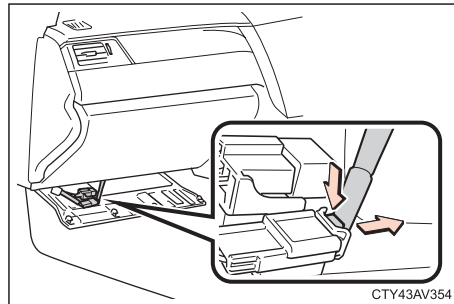

- Remove the fusebox lid.

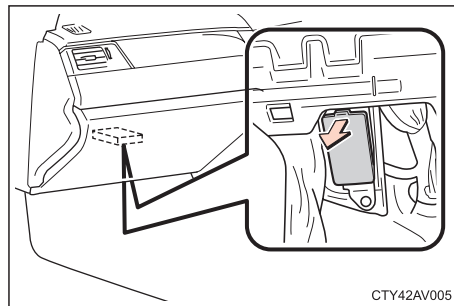

Fuse Removal

For fuse descriptions and amperages refer to "Fuse layout and amperage ratings" on page 286. The amperage rating is also inside the fuse box lid. Several types of fuses are used.

Type A-

- Only type A fuses can be removed using the removal tool.
- Remove the fuse by pulling it straight out and check if it has blown.

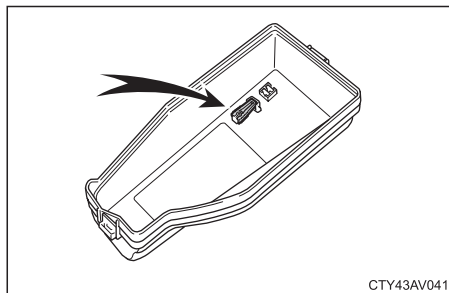

1. Normal fuse.
 2. Blown fuse.
- Replace the blown fuse with a new fuse of the same amperage rating.

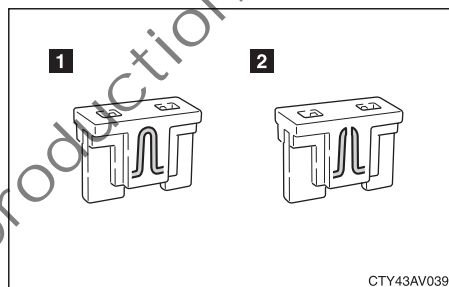

Type B-

1. Normal fuse.
 2. Blown fuse.
- Remove the fuse by pulling it straight out and check if it has blown.
 - Replace the blown fuse with a new fuse of the same amperage rating.

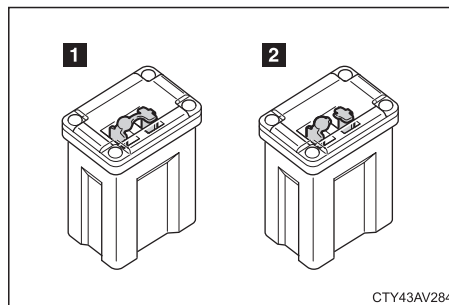

Type C-

1. Normal fuse.
 2. Blown fuse.
- Contact your Toyota dealer.

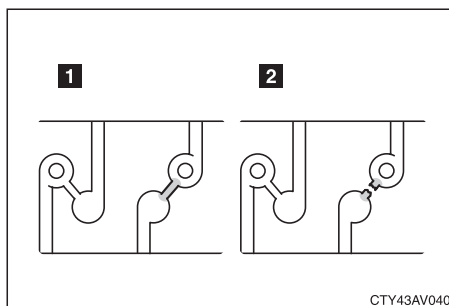

Do-it-yourself maintenance

If you cannot use a fuse of the same amperage, use one that is lower, but as close to the rating as possible. If the amperage is lower than that specified, the fuse might blow out again but this does not indicate anything wrong. Obtain the correct fuse as soon as possible and return the substitute to its original clip.

It is a good idea to purchase a set of spare fuses and keep them in your vehicle for emergencies.

If the new fuse immediately blows out, there is a problem with the electrical system. Have your Toyota dealer correct it as soon as possible.

CAUTION

- Never use a fuse with a higher amperage rating, or any other object, in place of a fuse. This may cause extensive damage and possibly a fire.
- Always use a genuine Toyota fuse or equivalent.
Never replace a fuse with a wire, even as a temporary fix.
This can cause extensive damage or even fire.
- Do not modify the fuses or the fuse boxes.

NOTICE

Before replacing fuses have the cause of electrical overload determined and repaired by your Toyota dealer as soon as possible.

FUSE LAYOUT AND AMPERAGE RATINGS

Engine compartment fuse block

Fuse block–

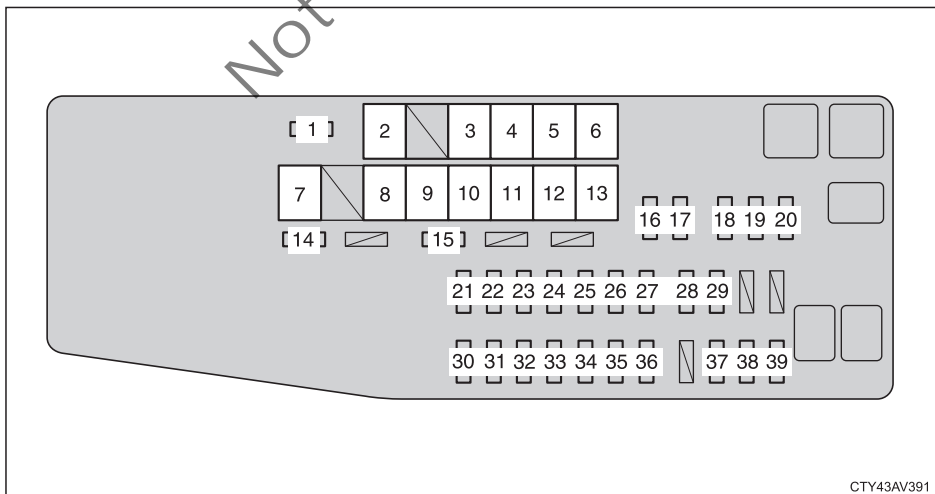

CTY43AV391

Do-it-yourself maintenance

Fuse block cover (inside)-

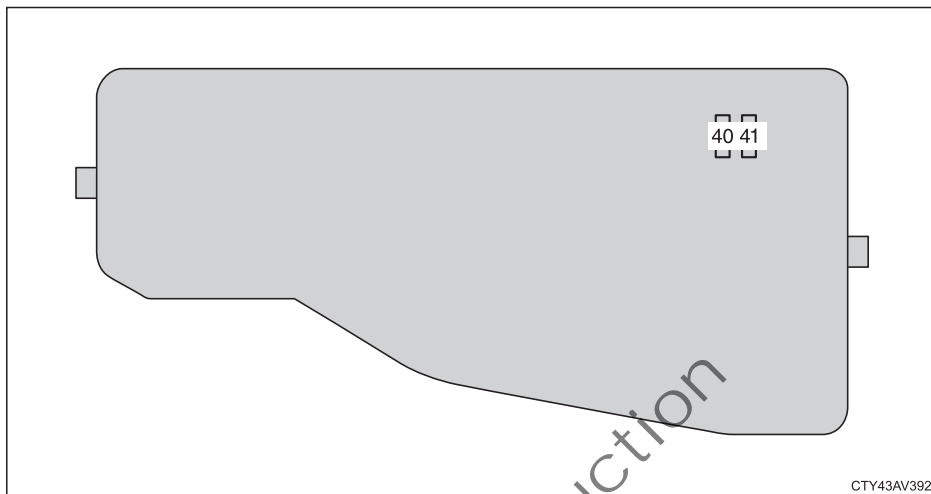

CTY43AV392

Fuse		Amperage	Circuit
1	METER-IG2	5 A	Gauge and meters
2	FAN	50 A	Electric cooling fans
3	ENG W/PMP	30 A	ENG W/PMP
4	PTC HTR NO.2	50 A	PTC heater
5	PTC HTR NO.1	50 A	PTC heater
6	HTR	50 A	Air conditioning system
7	DC/DC	120 A	Hybrid system
8	ABS NO.1	30 A	Electronically controlled brake system
9	H-LP-MAIN	30 A	"H-LP LH-LO", "H-LP RH-LO", headlights (low beam)
10	ABS MTR NO.2	50 A	Electronically controlled brake system
11	ABS MTR NO.1	50 A	Electronically controlled brake system
12	R/B NO.2	50 A	IGCT-MAIN, INV W/PMP
13	EPS	80 A	Electric power steering
14	S-HORN	7.5 A	Security horn
15	HORN	10 A	Horns
16	EFI NO.2	15 A	Fuel injection system
17	EFI NO.3	7.5 A	Fuel injection system
18	INJ	7.5 A	Fuel injection system
19	ECU-IG2 NO.3	7.5 A	Fuel injection system

Do-it-yourself maintenance

Fuse		Amperage	Circuit
20	IGN	15 A	Starter system
21	D/L-AM2	20 A	Power door lock system
22	IG2-MAIN	25 A	"IGN", "INJ", "METER-IG2", "ECU-IG2 NO.3", "A/B", "ECU-IG2 NO.2", "ECU-IG2 NO.1"
23	DC/DC-S	7.5 A	Hybrid system
24	TOWING	20 A	Trailer lights
25	TURN&HAZ	15 A	Turn signal lights, emergency flashers, outside rear view mirrors, gauge and meters, trailer turn lights
26	STRG LOCK	10 A	Steering lock system
27	AMP	15 A	Audio system
28	H-LP LH-LO	15 A	Left-hand headlight (low beam)
29	H-LP RH-LO	15 A	Right-hand headlight (low beam)
30	EFI-MAIN NO.1	30 A	Fuel injection system, "EFI NO.2", "EFI NO.3"
31	SMART	5 A	Smart entry & start system
32	ETCS	10 A	Electronic throttle control system
33	ABS NO.2	7.5 A	Electronically controlled brake system
34	EFI NO.1	7.5 A	Fuel injection system
35	EFI-MAIN NO.2	20 A	A/F sensor
36	AM2	7.5 A	Hybrid system
37	RADIO-B	20 A	Audio system, navigation system
38	DOME	7.5 A	Clock, vanity lights, interior lights, personal lights, boot light
39	ECU-B NO.1	10 A	Front power seats, outside rear view mirrors, multiplex communication system, smart entry & start system, gauge and meters, steering sensor
40	SPARE	25 A	A Spare fuse
41	SPARE	30 A	Spare fuse

Engine compartment fuse block (hybrid system)

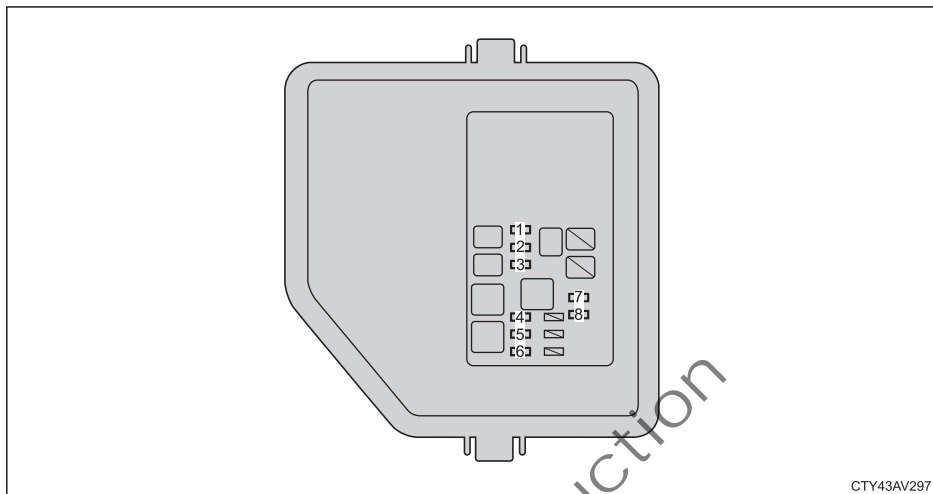

CTY43AV297

Fuse		Amperage	Circuit
1	PM IGCT	7.5 A	Hybrid system, electronic controlled transmission
2	BATT VL SSR	10 A	Hybrid system
3	INV	7.5 A	Hybrid system
4	DC/DC IGCT	10 A	Hybrid system
5	INV W/PMP RLY	7.5 A	Hybrid system
6	BATT FAN	7.5 A	Battery cooling fan
7	INV W/PMP	15 A	Hybrid system
8	IGCT-MAIN	25 A	"DC/DC IGCT", "INV", "BATT VL SSR", "PM IGCT", "INV W/PMP RLY", "BATT FAN"

Do-it-yourself maintenance

Instrument panel fuse block

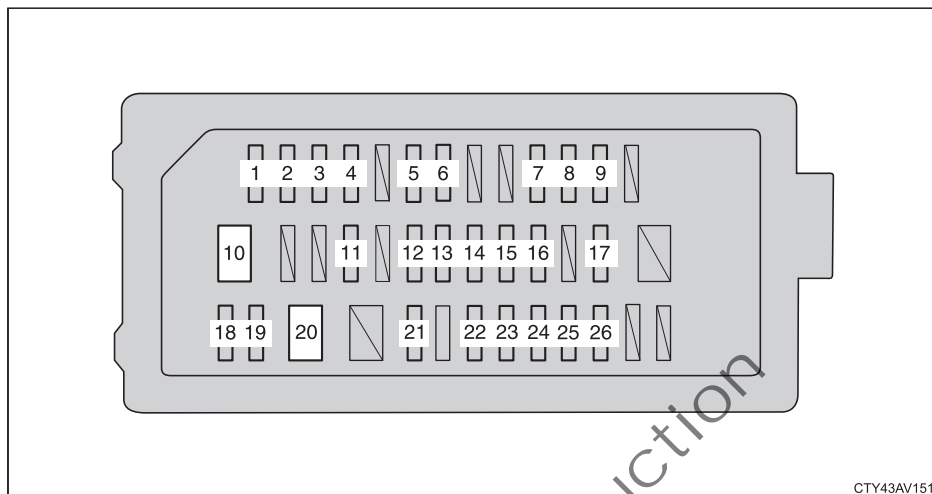

Fuse		Amperage	Circuit
1	ECU-IG1 NO.2	10 A	Outside rear view mirrors, Toyota parking assist-sensor, shift lock control system, windshield wipers and washer, rear sunshade, multiplex communication system, audio system, navigation system, moon roof, auto anti-glare inside rear view mirror, clock
2	ECU-IG1 NO.1	10 A	Electronically controlled brake system, electric cooling fans, stop lights, steering sensor, fuel injection system, rear window defogger, back-up lights, audio system, navigation system, Toyota parking assist-sensor, trailer back-up lights
3	PANEL	10 A	Switch illumination, air conditioning system, shift lever light, glove box light, interior lights, personal lights, audio system, navigation system
4	TAIL	15 A	Front position lights, tail lights, license plate lights, fog lights, trailer tail lights
5	EPS-IG1	7.5 A	Electric power steering
6	ECU-IG1 NO.3	7.5A	Blind Spot Monitor
7	WASHER	10 A	Windshield wipers and washer
8	A/C-IG1	7.5 A	Air conditioning system, PTC heater
9	WIPER	25 A	Windshield wipers and washer
10	DOOR NO.1	30 A	Power windows
11	P/OUTLET RR	20 A	Power outlet

Do-it-yourself maintenance

	Fuse	Amperage	Circuit
12	DOOR R/R	20 A	Rear right-hand power window
13	DOOR R/L	20 A	Rear left-hand power window
14	OBD	10 A	On-board diagnosis system
15	ECU-B NO.2	10 A	Rear sunshade
16	DOOR NO.2	20 A (*1)	Power windows
		25 A (*2)	Outside rear view mirrors
17	STOP	7.5 A	Tail lights, fuel injection system, high mounted stoplight, shift lock control system, hybrid system, electronically controlled brake system, trailer stop lights
18	A/C-B	7.5 A	Air conditioning system
19	S/ROOF	10 A	Moon roof
20	P/SEAT FR	30 A	Power seats
21	D/L-AM1	20 A	Multiplex communication system, power door lock, boot opener switch
22	A/B	10 A	SRS airbag system
23	ECU-IG2 NO.1	7.5 A	Fuel injection system
24	ECU-IG2 NO.2	7.5 A	Electronically controlled brake system, smart entry & start system
25	CIG&P/ OUTLET	15 A	Power outlet
26	ECU-ACC	7.5 A	Clock, outside rear view mirrors, multiplex communication system, audio system, navigation system

*1: Vehicles without driving position memory

*2: Vehicles with driving position memory

LIGHT BULBS

Light bulb locations

You may replace the light bulbs shown in the following illustrations. The difficulty level of replacement varies depending on the bulb. As there is a danger that components may be damaged, we recommend that replacement is carried out by your Toyota dealer.

When replacing a bulb, make sure the POWER switch and light switch are off.

CAUTION

- To prevent burning yourself, do not replace the light bulbs while they are hot.
- Halogen bulbs have pressurised gas inside and require special handling. They can burst or shatter if scratched or dropped. Hold a bulb only by its plastic or metal case. Do not touch the glass part of a bulb with bare hands.

Do-it-yourself maintenance

NOTICE

Only use a bulb of the listed type and wattage.

The inside of the lens of exterior lights such as headlights may temporarily fog up when the lens becomes wet in the rain or in a car wash. This is not a problem because the fogging is caused by the temperature difference between the outside and inside of the lens, just like the windscreen fogs up in the rain. However, if there is a large amount of water on the inside of the lens, or if there is water pooled inside the light, contact your Toyota dealer.

Front exterior lights—

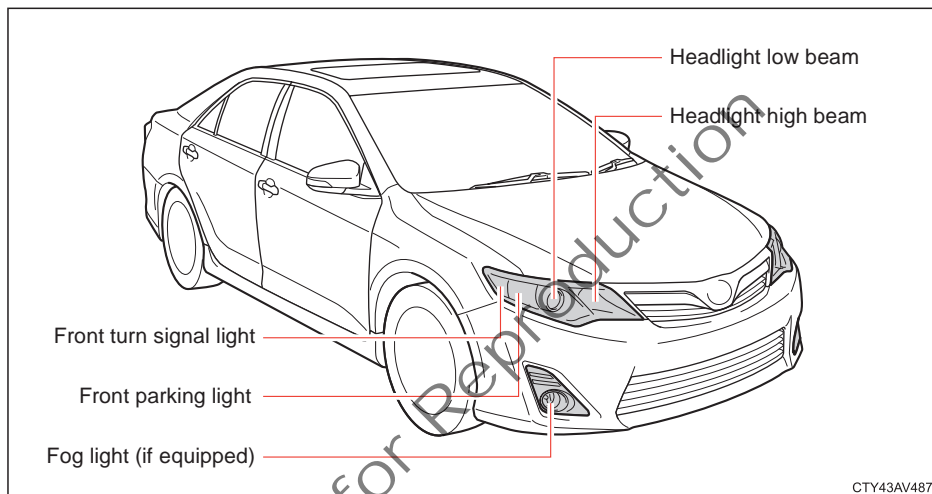

CTY43AV487

Bulb	Wattage	Bulb type
Headlight low beam	55	H7 halogen
Headlight high beam	60	HB3 halogen
Fog light	55	H11 halogen
Front parking light	5	Wedge base (clear)
Front turn signal light	21	Wedge base (amber)

Rear exterior lights–

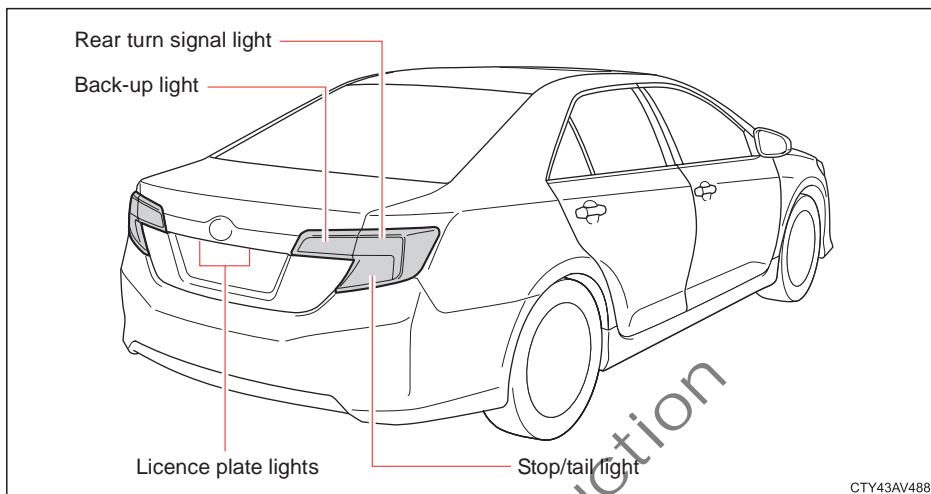

CTY43AV488

Bulb	Wattage	Bulb type
Stop/tail light	21/5	Wedge base (clear)
Rear turn signal light	21	Wedge base (amber)
Back-up light	16	Wedge base (clear)
License plate light	5	Wedge base (clear)

Other lights–

If any of the following light bulbs do not operate, take your vehicle to your Toyota dealer to have the light replaced:

- Side turn signal lights
- High mounted stop light
The high mounted stop light consists of a number of light emitting diodes (LEDs)
- Interior lights

Bulb	Wattage	Bulb type
Side turn signal light	5	Wedge base (amber)
Front interior / personal light	5	Wedge base (clear)
Interior light (*1)	8	Double end
Rear Interior / personal light (*2)	8	Wedge base (clear)
Boot light	3.8	Wedge base (clear)
Vanity lights	8	Wedge base (clear)

*1: Without moon roof

*2: With moon roof

Do-it-yourself maintenance

Headlight low beam

1. Open the bonnet.
2. Turn the headlight cover counterclockwise and remove it.

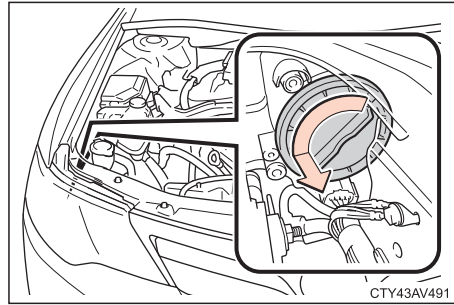

3. Turn the bulb base counterclockwise and remove the bulb base from the headlight.

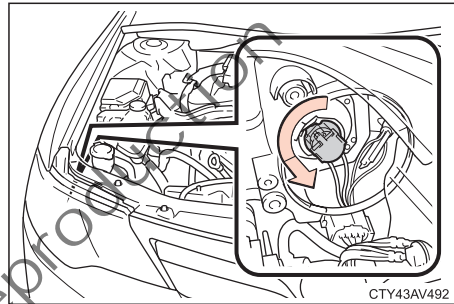

4. Remove the bulb from the bulb base.
5. Reinstall the new light bulb in the reverse of removal.

⚠ CAUTION

Hold the halogen bulb only by its plastic or metal case. Do not touch the glass part of a bulb with bare hands.

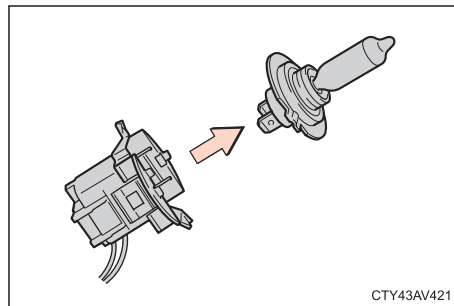

Headlight high beam

1. Open the bonnet.
2. Turn the headlight cover counterclockwise and remove it.

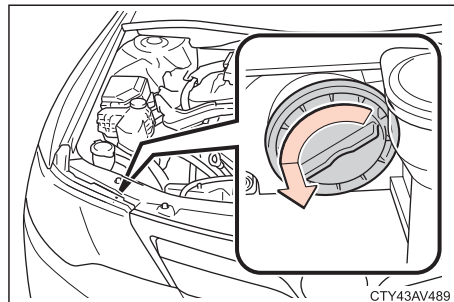

Do-it-yourself maintenance

3. Turn the bulb base counterclockwise and remove the bulb base from the headlight.

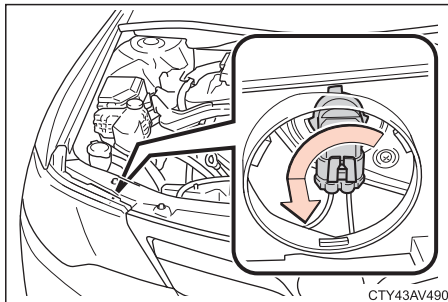

4. Remove the bulb base from the connector.
5. Reinstall the new light bulb in the reverse of removal.

CAUTION

Hold the halogen bulb only by its plastic or metal case. Do not touch the glass part of a bulb with bare hands.

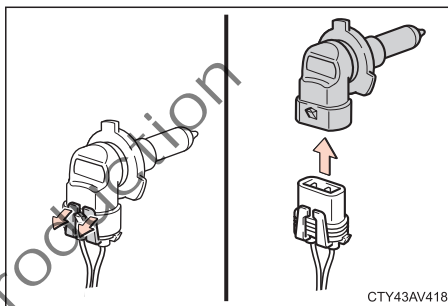

Parking light

1. Open the bonnet.
2. Turn the headlight cover counterclockwise and remove it.

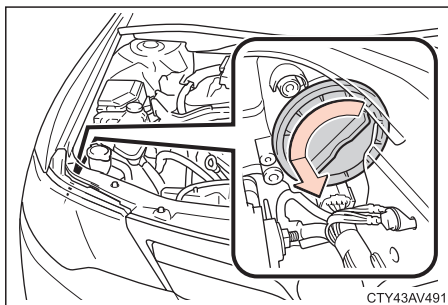

3. Turn the bulb base counterclockwise and remove the bulb base from the headlight.

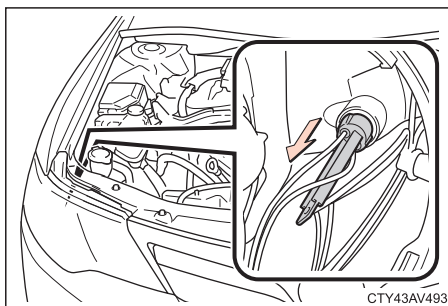

Do-it-yourself maintenance

4. Remove the light bulb from the bulb base.
5. Reinstall the new light bulb in the reverse of removal.

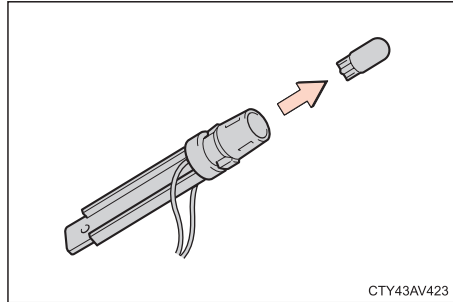

Front turn signal light

1. Open the bonnet.

Passenger's side only: To secure a working space, turn the headlight low beam cover counterclockwise and remove it.

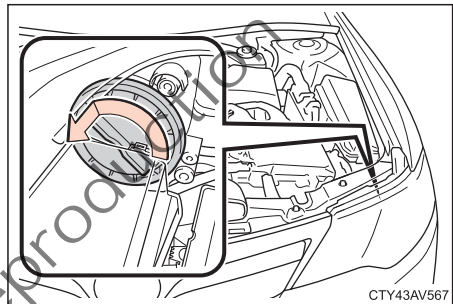

2. Turn the bulb base counterclockwise and remove the bulb base from the headlight.

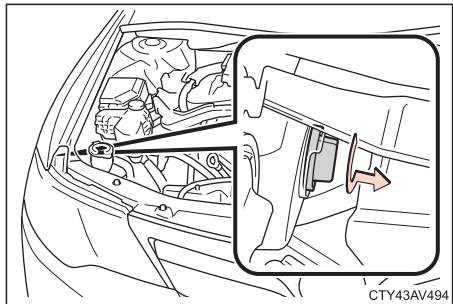

3. Remove the light bulb from the bulb base.
4. Reinstall the new light bulb in the reverse of removal.

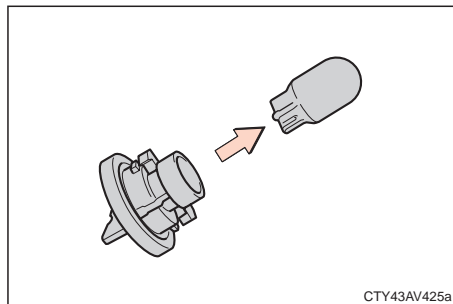

Do-it-yourself maintenance

Fog light

1. Turn the steering in the opposite direction to the fog light bulb that you wish to replace.
E.g. Turn the steering wheel left to replace the right-hand fog light bulb.

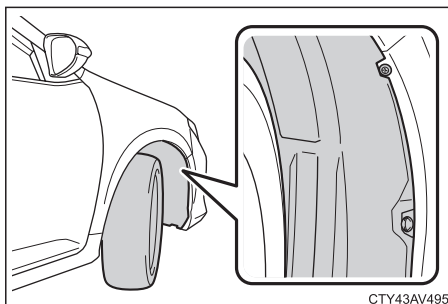

2. Remove the fender liner screws.

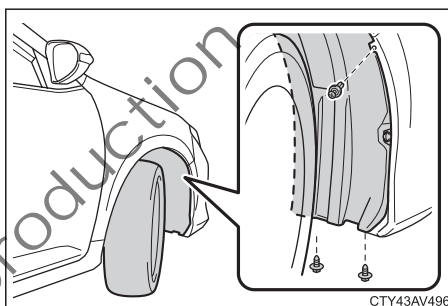

3. Remove the fender liner clip.

Step 1: After turning the clip, pull it out slightly until it stops.

Step 2: Turn the clip again and then remove it.

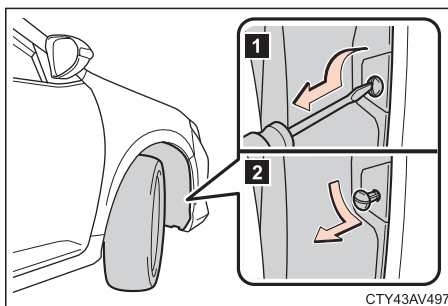

Do-it-yourself maintenance

4. Partly remove the fender liner.
5. Depress the connector lock release and disconnect the wiring connector.

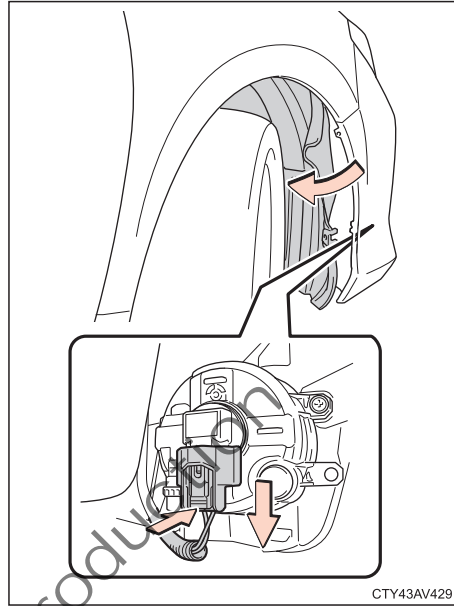

6. Turn the bulb base counter clockwise and remove the bulb base from the fog light.
7. Reinstall the new light bulb in the reverse of removal noting the following.

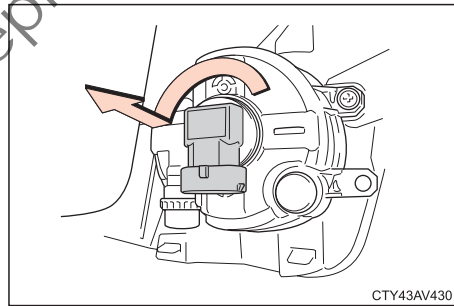

! CAUTION

Hold the halogen bulb only by its plastic or metal case. Do not touch the glass part of a bulb with bare hands.

- Insert the fender liner clip with the slot aligned vertically. Do not rotate the clip after installation.

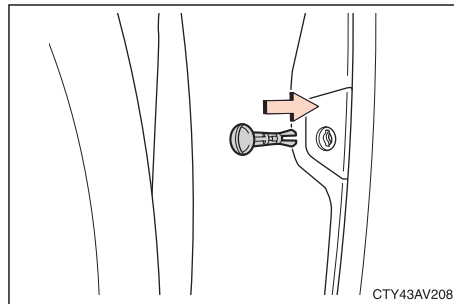

Rear turn signal and stop / tail light

 NOTICE

It is recommended your Toyota dealer replace the rear turn signal and stop / tail light bulbs as components can be damaged if care is not taken.

1. Open the boot lid.
2. Remove the luggage floor cover, spare wheel cushion and jack / tool cushions. Refer to "Location of the spare tyre, jack and tools" on page 313.
3. Remove the luggage finish panel clips.

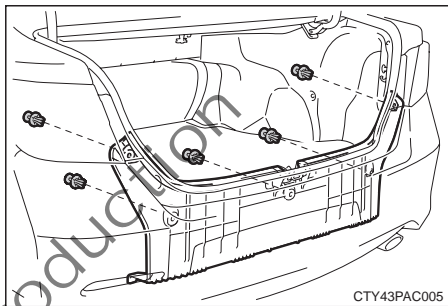

• HINT:

- To remove the trim clip, insert a small screwdriver and prise the centre retainer out slightly. Then remove the clip.
- To install the trim clip, insert the clip and push retainer in place.

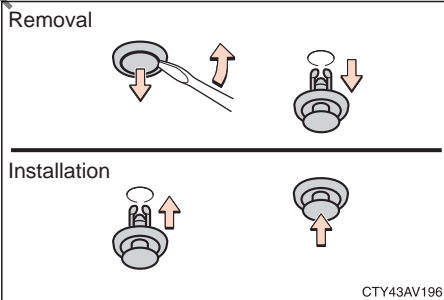

4. Remove the luggage finish panel by carefully pulling upward to disengage the four clips.

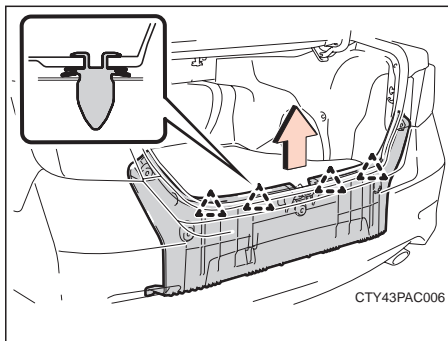

Do-it-yourself maintenance

5. Remove the 12-volt auxiliary battery cover.
6. Remove the luggage trim clips.

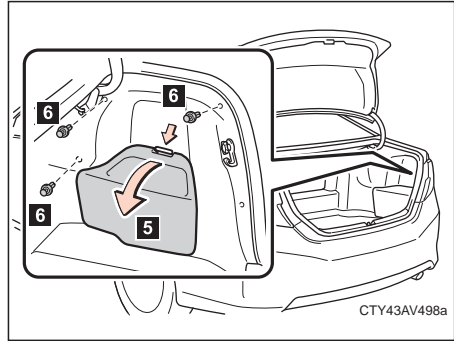

7. Pull the grocery hook while depressing the button.

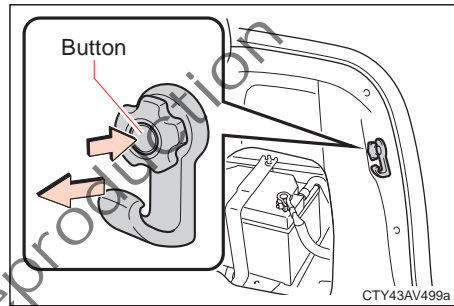

8. Carefully pull back the luggage trim cover to gain access to the light bulbs.

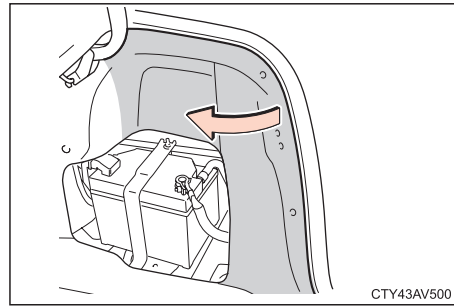

9. Turn the turn signal or stop / tail light bulb base counter clockwise and remove the bulb base from the combination light.

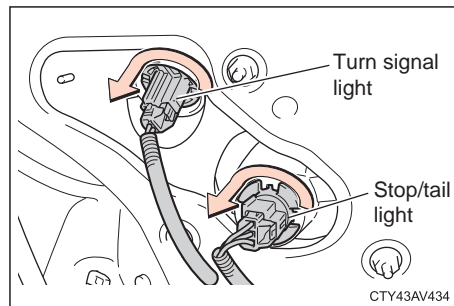

Do-it-yourself maintenance

10. Remove the light bulb from the bulb base.
11. Reinstall the new light bulb in the reverse of removal.

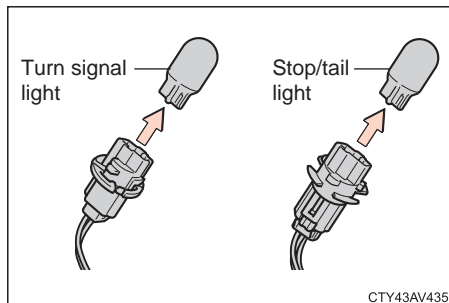

Back-up light

1. Open the boot lid.
2. Remove the boot lid trim cover clips and carefully pull the trim back to gain access to the light bulbs.

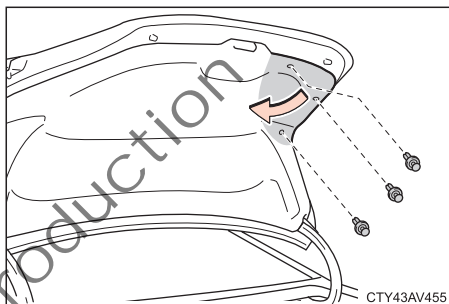

• HINT:

- To remove the trim clip, insert a small screwdriver and prise the centre retainer out slightly. Then remove the clip.
- To install the trim clip, insert the clip and push retainer in place.

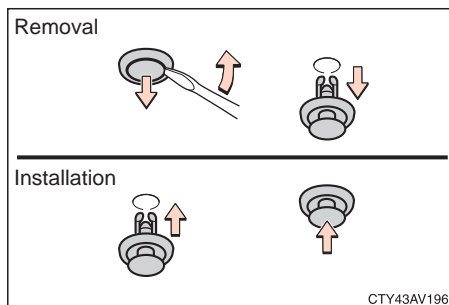

3. Depress the connector lock release and disconnect the wiring connector.

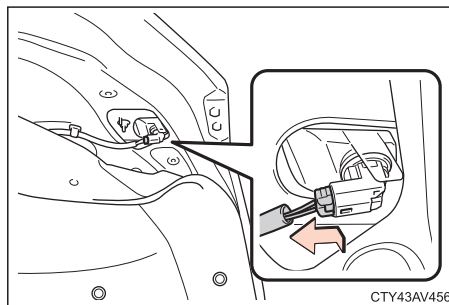

Do-it-yourself maintenance

- Turn the bulb base counterclockwise and remove the bulb base from the combination light.

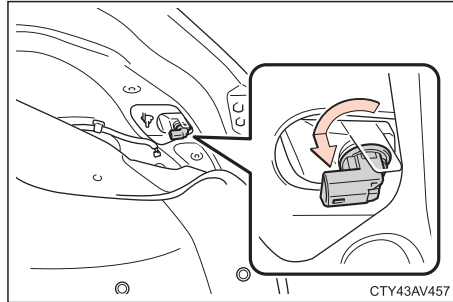

- Remove the light bulb from the bulb base.
- Reinstall the new light bulb in the reverse of removal.

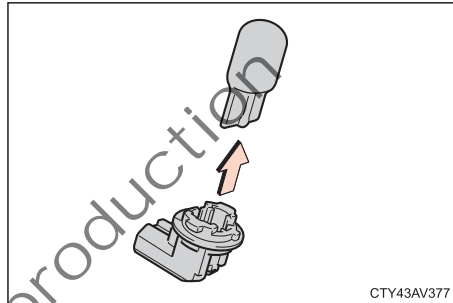

Licence plate light

- Insert a small flat-blade screw driver into the hole and prise off the licence plate light lens.
HINT: To prevent damage to the lens, wrap tape around the screw driver blade.

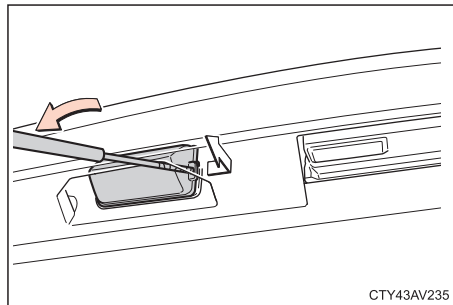

- Remove the light bulb from the bulb base.
- Reinstall the new light bulb in the reverse of removal.

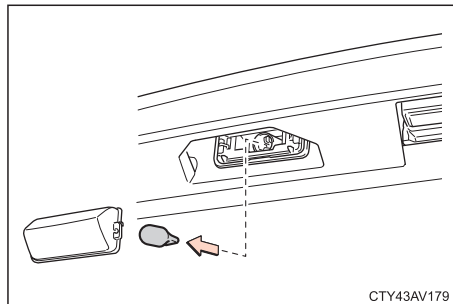

REPLACING THE REMOTE CONTROL TRANSMITTER BATTERY

If the key battery is discharged the following symptoms may occur:

- The wireless remote control and smart entry and start system will not function properly
- The operational range will be reduced

CAUTION

- Keep away from children. Swallowing the battery or any of its components may cause injury or death.
- Special care should be taken to prevent anyone from swallowing the removed transmitter battery or components.

NOTICE

- When replacing the remote control transmitter battery, be careful not to lose the components.
- Replace the battery only with the same or equivalent type recommended by a Toyota dealer.
- Dispose of used batteries according to the local laws.

For replacement, you must use a CR2032 lithium battery or equivalent.

1. Remove the mechanical key.

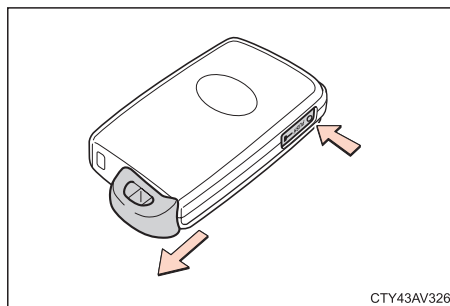

2. Cover the tip of the screwdriver with a rag or tape, etc.
3. Pry the key cover with the screwdriver and remove the cover.

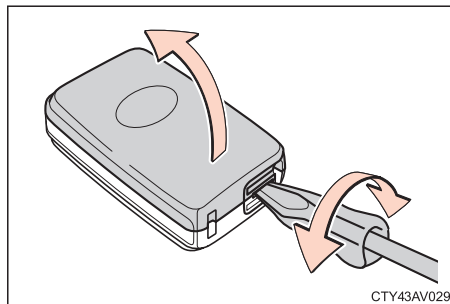

Do-it-yourself maintenance

4. Remove the discharged battery using a small flat-blade screw driver.
5. Insert a new battery with the positive [+] terminal facing up.
6. Reassemble the key in the reverse order of removal.

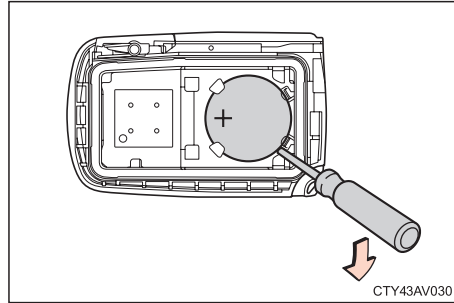

NOTICE

- Take care not to damage the circuit board.
- Do not bend the terminals.
- Make sure the positive side [+] of the transmitter battery is facing up.
- Do not replace the battery with wet hands. Water may cause corrosion.
- Close the transmitter case securely.

After replacing the battery, check the remote control and smart entry and start functions operate correctly. If they do not operate correctly, contact your Toyota dealer.

WHEN TROUBLE ARISES

Essential information	306
EMERGENCY FLASHERS	306
IF YOUR VEHICLE NEEDS TO BE TOWED	306
IF YOU THINK SOMETHING IS WRONG	310
Steps to take in an emergency	311
IF A WARNING LIGHT ILLUMINATES, A BUZZER SOUNDS OR A WARNING MESSAGE IS DISPLAYED ...	311
IF YOU HAVE A FLAT TYRE	312
IF THE HYBRID SYSTEM WILL NOT START	319
EMERGENCY START FUNCTION	320
IF THE SHIFT LEVER CANNOT BE MOVED FROM P POSITION	320
IF YOU LOSE YOUR KEYS	320
IF THE ELECTRONIC KEY DOES NOT OPERATE PROPERLY	321
IF THE 12-VOLT AUXILIARY BATTERY IS DISCHARGED	322
JUMP STARTING	323
IF YOUR VEHICLE OVERHEATS	325
IF YOUR VEHICLE BECOMES STUCK	328
IF YOUR VEHICLE HAS TO BE STOPPED IN AN EMERGENCY	328

Not for Reproduction



Essential information

Essential information

EMERGENCY FLASHERS

Use the emergency flashers to warn other drivers if your vehicle is stopped where it might be a traffic hazard.

Always pull off the road as far as possible.

- To turn on the emergency flashers, press the switch. All the turn signal lights will flash.
- To turn them off, press the switch once again.

The turn signal light switch will not work while the emergency flashers are operating.

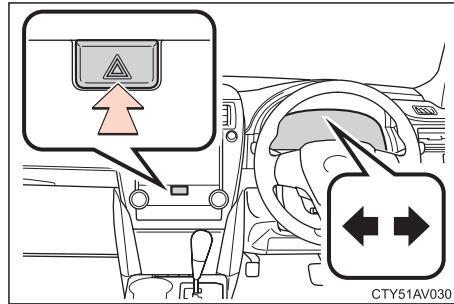

⚠ NOTICE

To prevent the 12-volt auxiliary battery from being discharged, do not leave the flashers on for a long period when the hybrid system is not running.

IF YOUR VEHICLE NEEDS TO BE TOWED

If towing is required, we recommend you to have it done by your Toyota dealer or a commercial tow truck service using a wheel-lift type truck or flatbed truck.

⚠ NOTICE

- Use a safety chain system for all towing and abide by the State and local laws.
- To prevent serious damage to the hybrid transmission, never tow a vehicle from the rear with four wheels or the front wheels on the ground.

Before towing

The following may indicate a problem with your hybrid transmission. Contact your Toyota dealer before towing.

- The hybrid system is operating, but the vehicle will not move.
- The vehicle makes an abnormal sound.

Towing with a sling-type truck

⚠ NOTICE

To prevent body damage, do not tow with a sling-type truck, either from the front or rear.

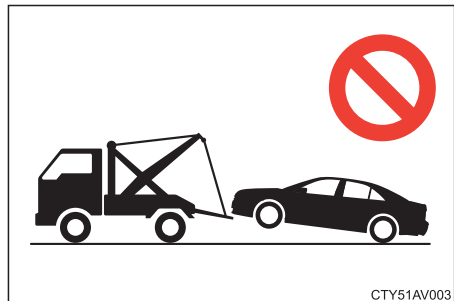

Towing with a wheel-lift type truck

NOTICE

- To prevent serious damage to the hybrid transmission, never tow the vehicle from the rear with the front wheels on the ground.
- To prevent damage to the vehicle, when raising the vehicle, ensure adequate ground clearance for towing at the opposite end of the raised vehicle.
Without adequate clearance, the vehicle could be damaged while being towed.

From the front–

- Release the parking brake.

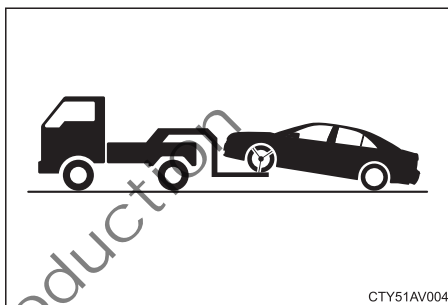

From the rear–

- Use a towing dolly under the front wheels.

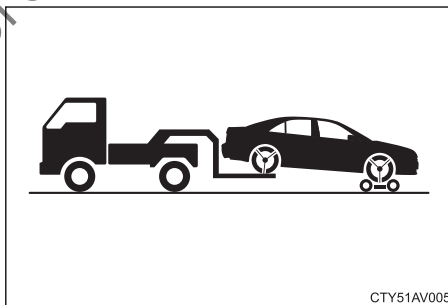

Using a flatbed truck

If you use chains or cables to tie down your vehicle, the angles shaded in black must be 45°.

Do not overly tighten the tie downs or the vehicle may be damaged.

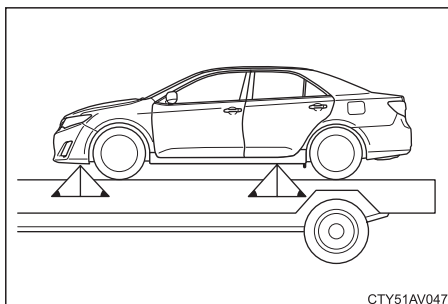

Essential information

Emergency towing

If a towing service is not available in an emergency, your vehicle may be temporarily towed by a cable, towing strap or chain secured to the emergency towing eyelet.

A driver must be in the vehicle to steer it and operate the brakes.

NOTICE

Use extreme caution when towing vehicles.

- Only use the specified towing eyelet; otherwise your vehicle may be damaged.
- Never tow the vehicle from the rear with the front wheels on the ground. This may cause serious damage to the transmission.
- Emergency towing may be done only on hard-surfaced roads for a short distance and at low speeds. Also, the wheels, axles, drivetrain, steering and brakes must all be in good working condition.

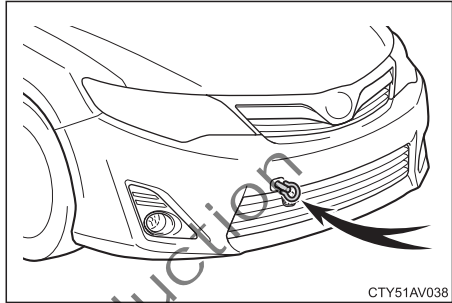

NOTICE

- Use only a cable, strap or chain specifically intended for use in towing vehicles.
- Securely fasten the cable or chain to the towing eyelet provided.
- Do not allow the cable, strap or chain to contact the vehicle body when towing. Doing so may damage the vehicle.

Before towing–

1. Release the parking brake.
2. Shift the shift lever to N position.
3. The POWER switch must be in ACCESSORY or ON mode.

CAUTION

- If the hybrid system is off, the power assistance for the brakes and steering will not work so steering and braking will be much harder than usual.
- Use extreme caution when towing the vehicle. Avoid sudden starts or erratic driving manoeuvres which place excessive stress on the emergency towing eyelets and the cables or chains.
- Always be cautious of the surroundings and other vehicles while towing.

Installing the front towing eyelet

! CAUTION

When installing the eyelet on the vehicle, tighten the front eyelet securely. If the eyelet is loose, it may come off when being towed and result in death or serious injury.

1. Remove the front towing eyelet from the underside of the spare tyre cover in the boot of the vehicle. Refer to "Location of the spare tyre, jack and tools" on page 313.

2. Remove the front towing eyelet cover on the front bumper using a flat-bladed screwdriver, wrapped with a cloth.

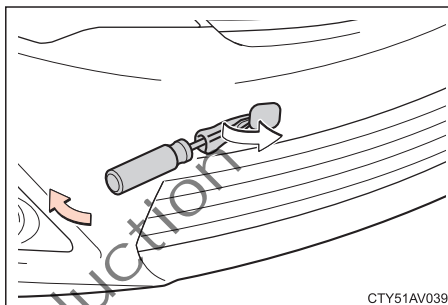

3. Insert the front towing eyelet into the hole on the bumper by turning clockwise.

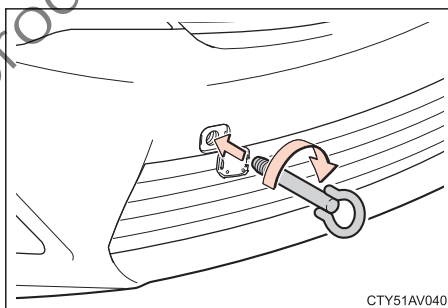

4. Tighten the front towing eyelet securely using a wheel nut wrench.

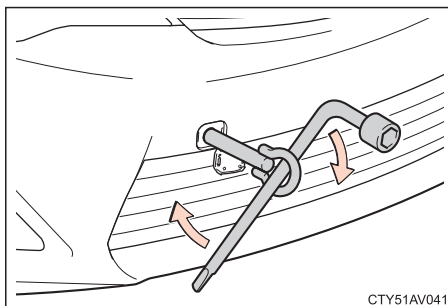

Essential information

IF YOU THINK SOMETHING IS WRONG

If you notice any of the following symptoms, your vehicle probably needs adjustment or repair. Contact your Toyota dealer as soon as possible.

Visible symptoms

- Fluid leaks under the vehicle (Water dripping from the air conditioning after use is normal).
- Flat-looking tyres or uneven tyre wear.
- The right-most segment of the engine coolant temperature display flashes.

Audible symptoms

- Changes in exhaust sound.
- Excessive tyre squeal when cornering.
- Strange noises related to the suspension system.
- Pinging or other noises related to the engine.

Operational symptoms

- Engine missing, stumbling or running roughly.
- Appreciable loss of power.
- Vehicle pulls heavily to one side when braking.
- Vehicle pulls heavily to one side when driving on a level road.
- Loss of brake effectiveness, spongy feeling, pedal almost touches the floor.

Not for Reproduction

Steps to take in an emergency

IF A WARNING LIGHT ILLUMINATES, A BUZZER SOUNDS OR A WARNING MESSAGE IS DISPLAYED

If a warning light illuminates or flashes, or if a buzzer sounds or a warning message is displayed on the multi-information display, this does not necessarily indicate a malfunction in the system. However, if this continues to occur, have the vehicle inspected by your Toyota dealer.

Check the details of the warning light illumination, buzzer or warning message; it may be simply that a door is not shut correctly, or the parking brake is not fully released, etc. For details refer to "Indicators and warning lights" on page 95 and "Warning messages" on page 100.

If the reason for the warning light illumination or buzzer sounding cannot be easily rectified, contact your Toyota dealer.

CAUTION

In some instances it may be dangerous to continue driving the vehicle.

SRS warning light

The SRS warning light monitors the entire SRS system including all of the airbag assemblies and seatbelt pretensioner assemblies, etc. For details refer to "Indicators and warning lights" on page 95.

CAUTION

If any of the following conditions occurs, this indicates a malfunction of the airbags or seatbelt pretensioners. Contact your Toyota dealer as soon as possible.

- The light does not come on when the POWER switch is pressed to ON mode or remains on for more than 6 seconds.
- The light comes on or starts flashing while driving.
- If any front seatbelt does not retract or cannot be pulled out due to a malfunction or activation of the relevant seatbelt pretensioner.
- The seatbelt pretensioner assembly or surrounding area has been damaged.

If the malfunction indicator warning light comes on while driving

The malfunction indicator warning light will illuminate if the fuel tank becomes completely empty. If this occurs, refuel the vehicle immediately. The malfunction indicator warning light will go off after several trips.

If the malfunction indicator warning light does not go off, contact your Toyota dealer as soon as possible.

Steps to take in an emergency

Electric power steering system warning light (warning buzzer)

When the 12-volt auxiliary battery charge becomes insufficient or the voltage temporarily drops, the electric power steering system warning light may come on and the warning buzzer may sound.

CAUTION

- When the electric power steering system warning light illuminates the steering wheel may become extremely heavy.
- If the steering wheel becomes heavier than usual when operating, hold firmly and operate using more force than usual.
- Drive slowly and carefully and contact your Toyota dealer as soon as possible.

IF YOU HAVE A FLAT TYRE

CAUTION

Do not get under a vehicle that is supported by a jack – use vehicle support stands.

1. Reduce your speed gradually, keeping a straight line. Move cautiously off the road to a safe place well away from the traffic. Avoid stopping on the centre divider of a highway. Park on a level spot with firm ground.
2. Stop the hybrid system and turn on your emergency flashers.
3. Firmly set the parking brake and put the transmission in P position.
4. Have everyone get out of the vehicle on the side away from traffic.
5. Read the following instructions thoroughly.

CAUTION

When jacking, observe the following to reduce the possibility of death or serious injury.

- Follow jacking instructions.
- Do not put any part of your body under the vehicle supported by the jack, otherwise personal injury may occur.
- Do not start or run the hybrid system while your vehicle is supported by the jack.
- Stop the vehicle on a level firm ground, firmly set the parking brake and put the transmission in P position.
- Chock the wheel diagonally opposite to the one being changed if necessary.
- Set the jack correctly in the jack point. Raising the vehicle with jack incorrectly positioned will damage the vehicle or may allow the vehicle to fall off the jack and cause personal injury.
- Never get under the vehicle when the vehicle is supported by the jack alone.
- Use the jack only for lifting your vehicle during wheel changing.
- Do not raise the vehicle with someone in the vehicle.
- When raising the vehicle, do not place any objects on top of or underneath the jack.

Steps to take in an emergency

⚠ CAUTION

- Raise the vehicle only high enough to remove and change the tyre.
- Failure to follow the following precautions could cause the wheel nuts to loosen and the tyre to fall off, resulting in death or serious injury:
 - Have the wheel nuts tightened with a torque wrench to 103 Nm (10.5 kg/f, 76 ft/lbf) as soon as possible after changing wheels
 - Do not attach a heavily damaged wheel ornament, as it may fly off the wheel while the vehicle is moving
 - When installing a tyre, only use wheel nuts that have been specifically designed for that wheel
 - If there are any cracks or deformations in the bolt screws, nut threads or bolt holes of the wheel, have the vehicle inspected by your Toyota dealer

⚠ NOTICE

- Do not continue driving with a deflated tyre. Driving even a short distance can damage a tyre and wheel beyond repair.
- Do not touch the wheels or the area around the brakes immediately after the vehicle has been driven as these areas will be extremely hot. Touching these areas may result in burns.

Location of the spare tyre, jack and tools

To prepare yourself for an emergency, you should familiarise yourself with the use of the jack, each of the tools and their storage locations.

Vehicles with a steel spare tyre—

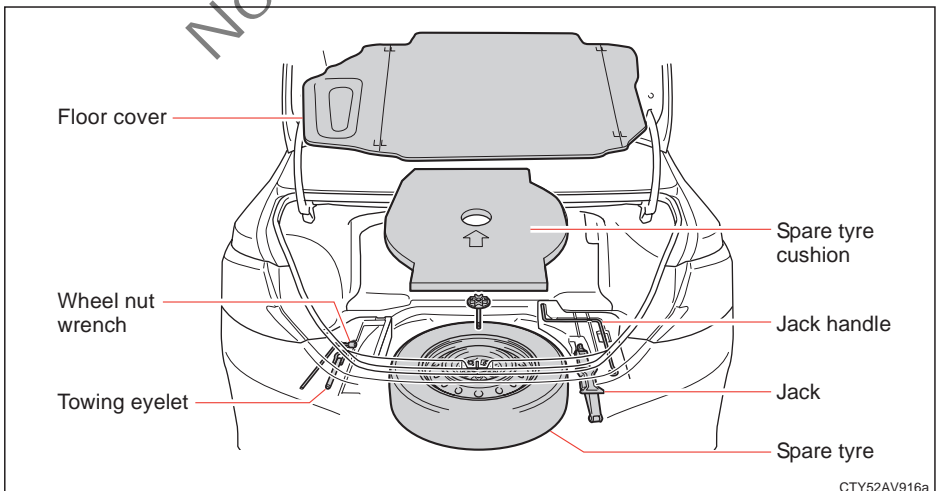

CTY52AV916a

Steps to take in an emergency

Vehicles with an aluminium spare tyre—

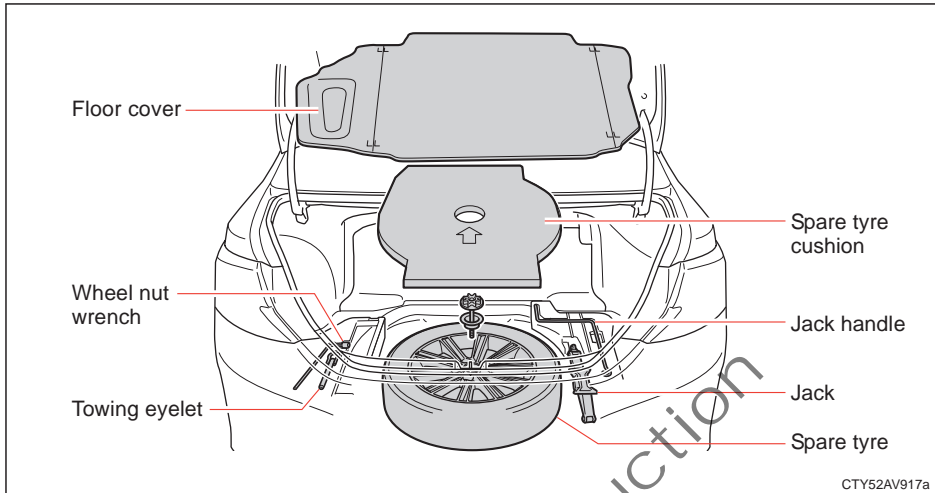

Vehicle jack maintenance—

Ensure the jack is maintained correctly and is ready for use.

- Inspect the jack before use.
- Always keep the jack clean and the moving parts free from dirt, rust, etc.
- Make sure the screw thread is adequately lubricated.

Jack removal

1. Open the boot lid and lift up the luggage floor cover.

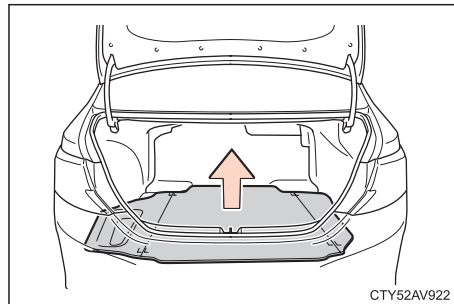

Steps to take in an emergency

2. Remove the jack.

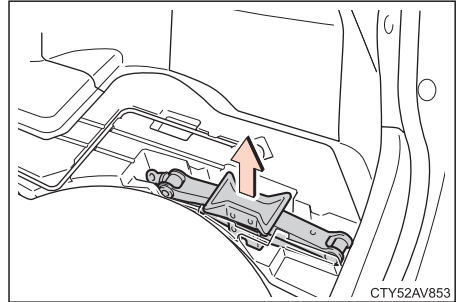
**Spare tyre removal**

1. Open the boot lid and lift up the luggage floor cover.

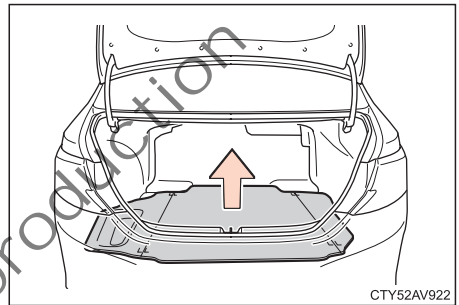

2. Remove the spare tyre cushion.

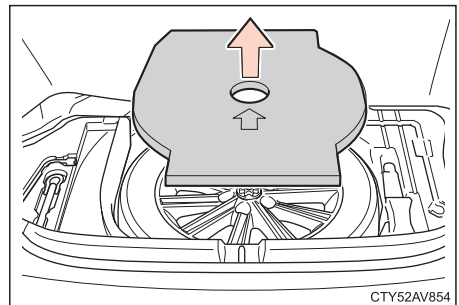

3. Remove the retainer securing the spare tyre.
 - For vehicles with an aluminium spare wheel, also remove the spacer.
4. Carefully remove the spare tyre.
 - When storing the spare tyre, put it in place with the outer side of the wheel facing up.

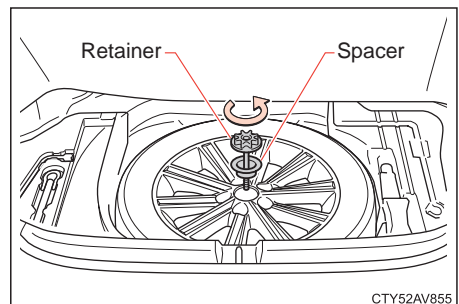

Steps to take in an emergency

- Secure the tyre in the boot by repeating the removal steps in reverse order to prevent it from flying forward during a collision or sudden braking.

Removing a flat tyre

1. Chock the wheel diagonally opposite the flat tyre to keep the vehicle from rolling when it is jacked up.

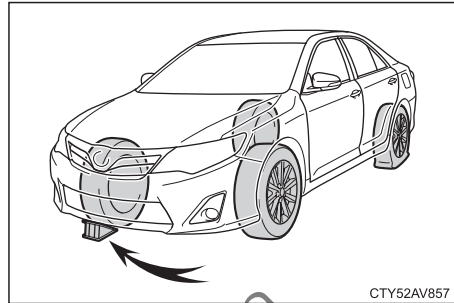

2. Slightly loosen each wheel nut (up to one turn).

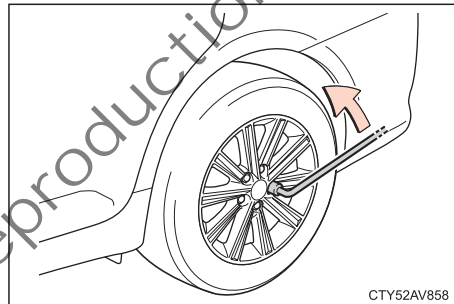

3. Position the jack under the vehicle's rocker panel at the jacking point closest to the flat tyre.
 - Turn the jack screw, part A, by hand until the recess in the jack is in contact with the jack point.
 - Position the jack so it is between the notches in the rocker panel flange.

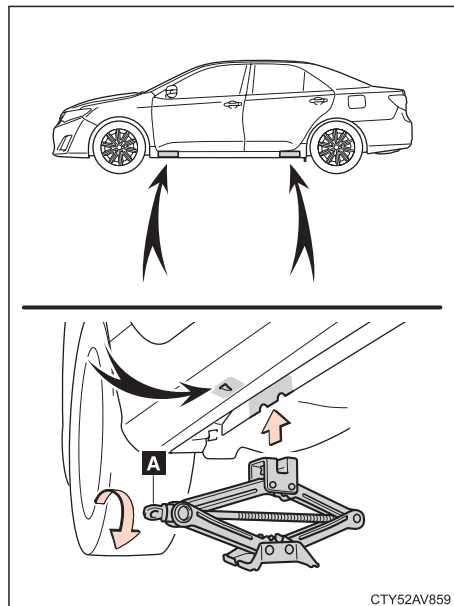

Steps to take in an emergency

4. Insert the jack handle and raise the vehicle until the tyre is off the ground.
 - Remember to raise the vehicle a bit extra to allow for the deflated portion of the tyre.

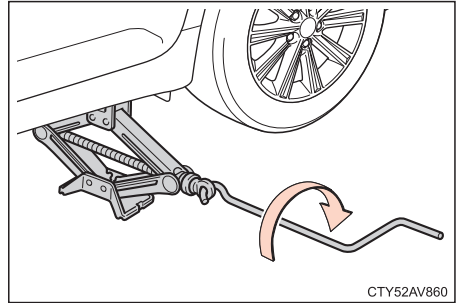

5. Remove the wheel nuts and the wheel.
 - If resting the wheel on the ground, take care to avoid damaging the wheel outer surface.

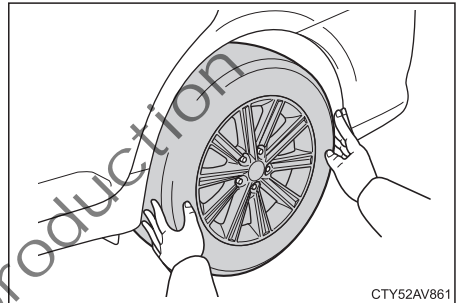
**Installing the spare tyre**

1. Remove any dirt or foreign material from the wheel contact surfaces.
 - If foreign matter is on the wheel contact surface, the wheel nuts may loosen while the vehicle is in motion, causing the wheel to come off.
 - If resting the wheel on the ground, take care to avoid damaging the wheel outer surface.
2. Install the wheel and loosely tighten each wheel nut by hand approximately the same amount.
 - When installing a steel wheel, tighten the wheel nuts until the tapered portion comes into contact with the disc wheel seat.

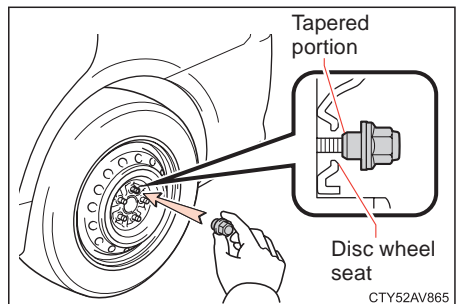
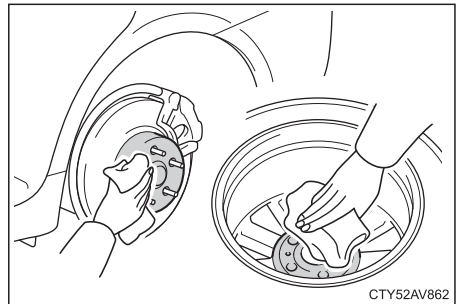

Steps to take in an emergency

- When installing an aluminium wheel, turn the wheel nuts until the washers come into contact with the disc wheel.

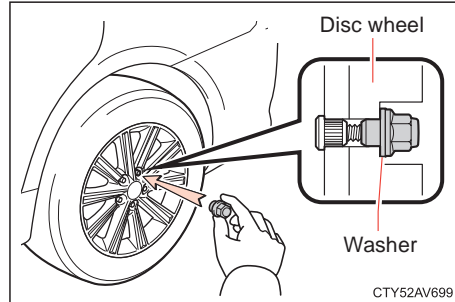

⚠ CAUTION

When installing the wheel nuts

- For steel wheels install the wheel nuts with the tapered ends facing inward. Installing the nuts with the tapered ends facing outward can cause the wheel to break and eventually cause the wheel to come off while driving, which could lead to an accident resulting in death or serious injury.
- Never use oil or grease on the wheel bolts or wheel nuts. Oil and grease may cause the wheel nuts to be excessively tightened, leading to bolt or disc wheel damage. In addition, the oil or grease can cause the wheel nuts to loosen and the wheel may fall off, causing an accident and resulting in death or serious injury. Remove any oil or grease from the wheel bolts or wheel nuts.

3. Lower the vehicle.

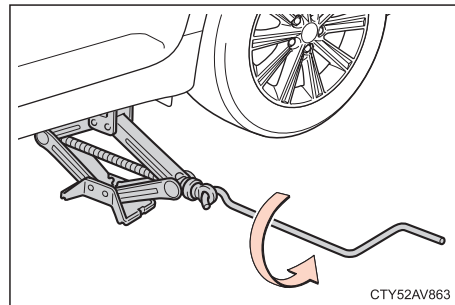

4. Firmly tighten each wheel nut two or three times in the order shown in the illustration.

- As soon after changing wheels as possible, tighten the wheel nuts to the correct torque specification.

Tightening torque:
103 Nm (10.5 kg/f, 76 ft/lbf)

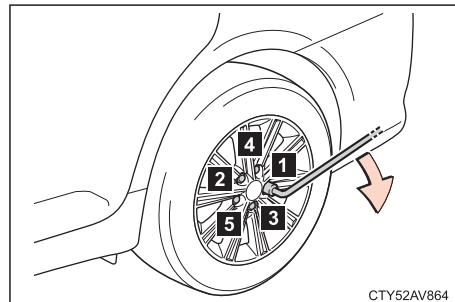

After changing wheels

- Check the air pressure of the replaced tyre.

Adjust the air pressure to the specification designated, refer to “Tyres and wheels” on page 338. If the pressure is lower, drive slowly to the nearest service station and fill to the correct pressure.

Do not forget to reinstall the tyre inflation valve cap as dirt and moisture could get into the valve core and possibly cause air leakage. If the cap is missing, have a new one put on as soon as possible.

- Restow all the tools, jack and flat tyre securely.
- Have a technician repair the flat tyre.

! CAUTION

Before driving, make sure all the tools, jack and flat tyre are securely in place in their storage location to reduce the possibility of personal injury during a collision or sudden braking.

IF THE HYBRID SYSTEM WILL NOT START**Simple checks**

Reasons for the hybrid system not starting vary depending on the situation. Check the following and perform the appropriate procedure:

The hybrid system will not start even though the correct starting procedure is being followed. Refer to “Starting the hybrid system” on page 79.

One of the following may be the cause of the problem:

- The electronic key may not be functioning properly. Refer to “If the electronic key does not operate properly” on page 321.
- There may not be sufficient fuel in the vehicle’s tank. Refuel the vehicle.
- There may be a malfunction in the immobiliser system. Refer to “Engine immobiliser system” on page 57.
- There may be a malfunction in the steering lock system. Refer to “Steering lock” on page 81.
- The hybrid system may be malfunctioning due to an electrical problem such as an open circuit or a blown fuse. However, depending on the type of malfunction, an interim measure is available to start the hybrid system. Refer to “Emergency start function” on page 320.

The interior lights and headlights are dim, or the horn does not sound or sounds at a low volume.

One of the following may be the cause of the problem:

- The 12-volt auxiliary battery may be discharged. Refer to “If the 12-volt auxiliary battery is discharged” on page 322.
- The 12-volt auxiliary battery terminal connections may be loose or corroded.

Steps to take in an emergency

The interior lights and headlights do not turn on, or the horn does not sound.

One of the following may be the cause of the problem:

- One or both of the 12-volt auxiliary battery terminals may be disconnected.
- The 12-volt auxiliary battery may be discharged. Refer to “If the 12-volt auxiliary battery is discharged” on page 322.

Contact your Toyota dealer if the problem cannot be repaired, or if repair procedures are unknown.

EMERGENCY START FUNCTION

When the hybrid system does not start, the following steps can be used as an interim measure to start the hybrid system if the POWER switch is functioning normally:

1. Set the parking brake.
2. Shift the shift lever to P.
3. Press the POWER switch to ACCESSORY mode.
4. Press and hold the POWER switch for about 15 seconds while depressing the brake pedal firmly.

Even if the hybrid system can be started using the above steps, the system may be malfunctioning. Have the vehicle inspected by your Toyota dealer.

If the hybrid system cannot be started using the above procedure, contact your Toyota dealer.

IF THE SHIFT LEVER CANNOT BE MOVED FROM P POSITION

If the shift lever cannot be shifted from P position even though the brake pedal is depressed and the POWER switch is in ON mode, there may be a problem with the shift lock system (a system to prevent accidental operation of the shift lever). Have the vehicle inspected by your Toyota dealer immediately.

The following steps may be used as an emergency measure to ensure that the shift lever can be shifted:

1. Set the parking brake.
2. Press the POWER switch to ACCESSORY mode.
3. Depress the brake pedal.
4. Press and hold the shift lock override button and move the shift lever. You can only shift out of P position while pressing the button.

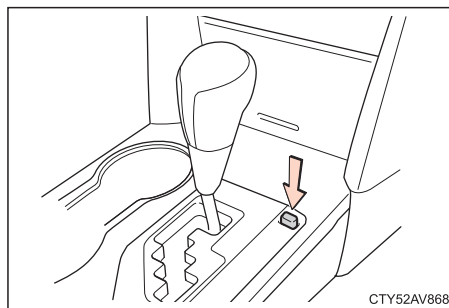

IF YOU LOSE YOUR KEYS

You can purchase a genuine new key at your Toyota dealer. Bring the remaining key(s) and provide the key number that is stamped on the key number plate.

IF THE ELECTRONIC KEY DOES NOT OPERATE PROPERLY

If communication between the electronic key and the vehicle is interrupted or the electronic key cannot be used because the battery is discharged, the smart entry and start system and wireless remote control cannot be used. In such cases, the doors and boot lid can be opened and the hybrid system can be started using the following procedures.

NOTICE

- As the following procedures are a temporary measure, it is recommended the electronic key battery be replaced immediately if the battery is discharged.
- If the doors cannot be locked or unlocked by the smart entry and start system, lock and unlock the doors by the mechanical key or wireless remote control.
- When the electronic key does not work properly, check the smart entry and start system has not been deactivated through customisation. For further information refer to “Customisable features” on page 339.
- Check if battery-saving mode is set. If it is set, cancel the function. For details refer to “Battery-saving function” on page 24

Locking and unlocking the doors

Use the mechanical key to perform the following operations for the driver's door:

1. Locks all the doors.
2. Closes the windows and moon roof (turn and hold)*.
3. Unlocks the door.
Turning the key rearward unlocks the driver's door. Turning the key once again unlocks the other doors.
4. Opens the windows and moon roof (turn and hold)*.

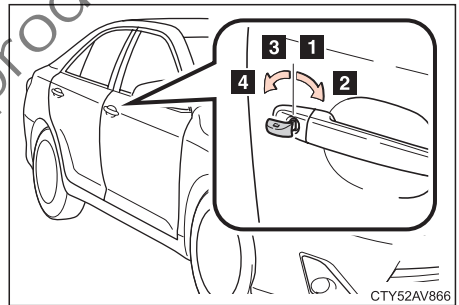

*: This setting must be customised by your Toyota dealer. Refer to “Customisable features” on page 339.

Starting the hybrid system

1. Place the shift lever in P position and firmly depress the brake pedal.
2. Touch the Toyota emblem side of the electronic key to the POWER switch.
The POWER switch will change to ON mode.
 - If the smart entry and start system has been deactivated through customisation, the POWER switch will change to ACCESSORY mode.

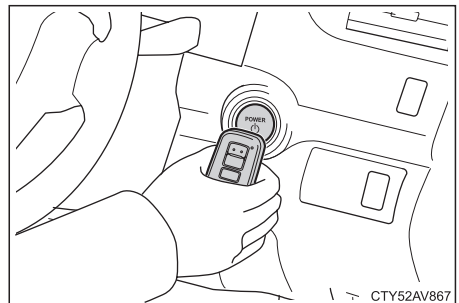

Steps to take in an emergency

3. Firmly depress the brake pedal and check that  is displayed on the multi-information display.
4. Press the POWER switch.

In the event the hybrid system still cannot be operated, contact your Toyota dealer.

Changing the POWER switch mode

With  displayed, the modes can be changed by pressing the POWER switch with brake pedal released. (The mode changes each time the switch is pressed.)

Stopping the hybrid system

Move the shift lever to P position and press the POWER switch as you normally do when stopping the hybrid system..

IF THE 12-VOLT AUXILIARY BATTERY IS DISCHARGED

Starting the hybrid system when the 12-volt auxiliary battery is discharged

The hybrid system cannot be started by push-starting. If the 12-volt auxiliary battery is discharged, the hybrid system can only be started by fitting a replacement 12-volt auxiliary battery or by jump starting.

To prevent 12-volt auxiliary battery discharge

- Turn off the headlights and the audio system while the hybrid system is off.
- Turn off any unnecessary electrical components when the vehicle is running at a low speed for an extended period, such as in heavy traffic.

Smart entry and start system

- In some cases it may not be possible to unlock the doors using the smart entry and start system when the 12-volt auxiliary battery is discharged. Use the wireless remote control or the mechanical key to lock or unlock the doors.
- The hybrid system may not start on the first attempt after the 12-volt auxiliary battery has recharged but will start normally after the second attempt. This is not a malfunction.
- The POWER switch mode is memorised by the vehicle.

When the 12-volt auxiliary battery is reconnected, the system will return to the mode it was in before the 12-volt auxiliary battery was discharged.

Before disconnecting the 12-volt auxiliary battery, press the POWER switch off.

If you are unsure what mode the POWER switch was in before the 12-volt auxiliary battery discharged, be especially careful when reconnecting the 12-volt auxiliary battery.

Charging the 12-volt auxiliary battery

The electricity stored in the 12-volt auxiliary battery will discharge gradually, even when the vehicle is not in use, due to natural discharge and the draining effects of certain electrical systems.

If the vehicle is left for a long time, the 12-volt auxiliary battery may discharge and the hybrid system may be unable to start. The 12-volt auxiliary battery will recharge automatically during driving.

JUMP STARTING

To avoid serious personal injury and damage to your vehicle which might result from battery explosion, acid burns, electrical burns, or damaged electronic components, these instructions must be followed precisely.

If you are unsure about how to follow this procedure, we strongly recommend that you seek the help of a competent mechanic or towing service.

CAUTION

Avoiding battery fires or explosions

Observe the following precautions to prevent accidentally igniting the flammable gas that may be emitted from the battery.

- Make sure each jumper cable is connected to the correct terminal and that it is not unintentionally in contact with any part other than the intended terminal.
- Do not allow the [+] (red) and [-] (black) jumper cable clamps to come into contact with each other.
- Do not smoke, use matches, cigarette lighters or allow open flame near the 12-volt auxiliary battery.

CAUTION

Battery precautions

The 12-volt auxiliary battery contains poisonous and corrosive acidic electrolyte and parts made from lead and lead compounds. Observe the following precautions when handling the 12-volt auxiliary battery.

- Always wear safety glasses and take care not to allow any battery fluids (acid) to come into contact with skin, clothing or the vehicle.
- Do not lean over the 12-volt auxiliary battery.
- In the event that 12-volt auxiliary battery fluid comes into contact with the skin or eyes, immediately wash the affected area with water and seek medical attention. Place a wet sponge or cloth over the affected area until medical attention is received.
- Always wash your hands after handling any battery-related parts.
- Do not allow children near the 12-volt auxiliary battery.

Steps to take in an emergency

NOTICE

- The battery used for boosting must be 12 volts. Do not jump start unless you are sure the booster battery is correct.
- If the booster battery is installed in another vehicle, make sure the vehicles are not touching.
- Turn off all unnecessary lights and accessories.
- When connecting the jumper cables, ensure they do not become entangled in the cooling fans or belt.

Jump starting procedure

The following procedures may be used to start the hybrid system if the vehicle's 12-volt auxiliary battery is discharged.

You can also call your Toyota dealer or qualified repair shop.

If you have a set of jumper (or booster) cables and a second vehicle with a 12-volt battery, you can jump start your Toyota following the steps below.:

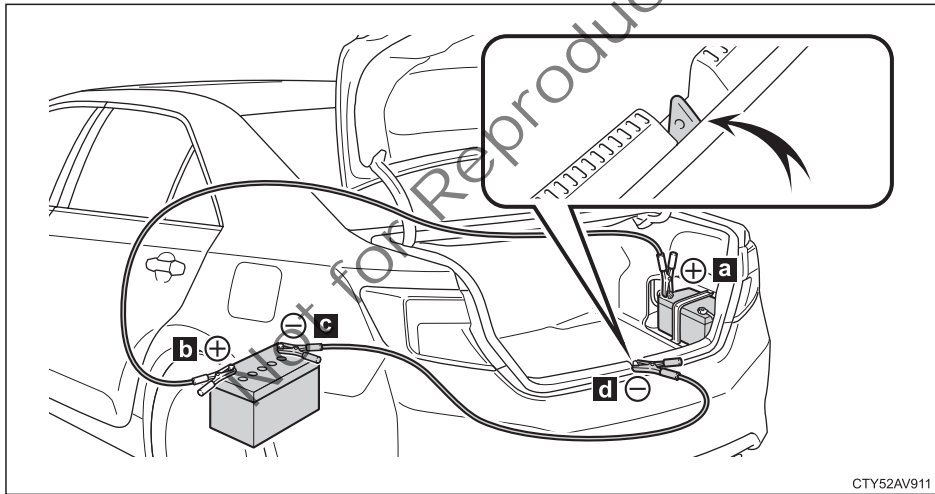

1. Open the boot lid and remove the 12-volt auxiliary battery cover.
2. Connect the jumper cables according to the following procedure:
 - a. Connect a positive jumper cable clamp to the exclusive jump starting terminal [+] on your vehicle.
 - b. Connect a positive jumper cable clamp to the positive [+] battery terminal on the second vehicle.
 - c. Connect a negative cable clamp to the negative [-] battery terminal on the second vehicle.
 - d. Connect the jumper cable to ground on your vehicle as shown in the illustration.

Steps to take in an emergency

3. Start the engine of the second vehicle. Increase the engine speed slightly and maintain at that level for approximately 5 minutes to recharge the 12-volt auxiliary battery of your vehicle.
4. Open and close any of the doors with the POWER switch OFF.
5. Maintain the engine speed of the second vehicle and press the POWER switch to ON mode, then start the hybrid system.
6. Make sure the READY indicator comes on. If the indicator does not come on, contact your Toyota dealer.
7. Once the hybrid system has started, remove the jumper cables in the exact reverse order from which they were connected.

Once the hybrid system starts, have the vehicle checked at your Toyota dealer as soon as possible.

IF YOUR VEHICLE OVERHEATS

The following may indicate that your vehicle is overheating:

- The rightmost segment of the engine coolant temperature display is flashing. The engine may be overheating.
- HYBRID SYSTEM OVERHEAT is shown on the multi-information display. The electric motor or power control unit may be overheating.
- Hybrid system output decreases.
- Steam comes from the engine area.

Follow the correction procedures as described below.

If the rightmost segment of the engine coolant temperature display is flashing:

1. Stop the vehicle in a safe place and turn off the air conditioning system.
2. Check to see if steam is coming out from the engine area.

If you see steam:

- Stop the hybrid system. Carefully lift the bonnet after the steam subsides and then restart the hybrid system.

If you do not see steam:

- Leave the hybrid system operating and carefully lift the bonnet.

3. Check to see if the cooling fans are operating.

If the fans are operating:

- Wait until the rightmost segment of the engine coolant temperature display stops flashing and returns to normal display. Then stop the hybrid system.

If the fans are not operating:

- Stop the hybrid system immediately and call your Toyota dealer.

Steps to take in an emergency

4. After the hybrid system has cooled down sufficiently, check the engine coolant level and inspect the radiator if any leaks.

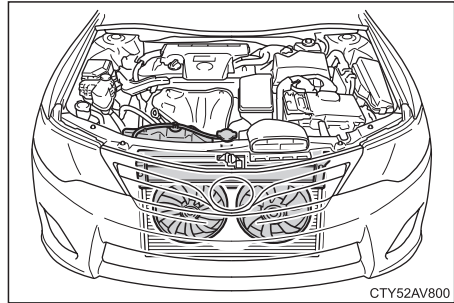

5. Add engine coolant if necessary.

Water can be used in an emergency if engine coolant is unavailable. Refer to "Cooling system" on page 336.

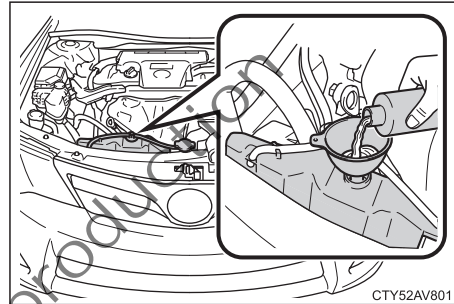

Have the vehicle inspected at the nearest Toyota dealer as soon as possible.

If HYBRID SYSTEM OVERHEAT is shown on the multi-information display:

1. Stop the vehicle in a safe place and turn off the air conditioning system.
2. Leave the hybrid system operating and carefully lift the bonnet.
3. Check if the cooling fans are operating.

If the fans are operating:

- Wait until the HYBRID SYSTEM OVERHEAT message disappears and then stop the hybrid system.

If the message does not disappear, call your Toyota dealer.

If the fans are not operating:

- Stop the hybrid system immediately and call your Toyota dealer.

4. After the hybrid system has cooled down, check the power control unit coolant level and inspect the cooling system for leaks.

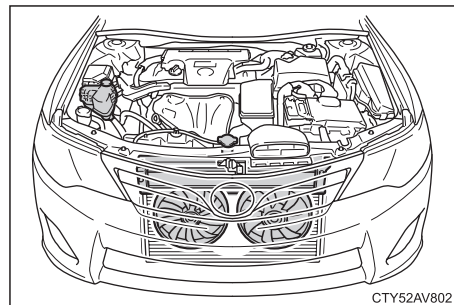

Steps to take in an emergency

5. Add power control unit coolant if necessary.

Water can be used in an emergency if power control unit coolant is unavailable. Refer to “Cooling system” on page 336.

Have the vehicle inspected at the nearest Toyota dealer as soon as possible.

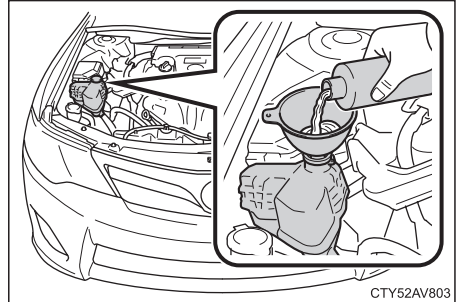

CTY52AV803

⚠ CAUTION

To prevent an accident or injury when inspecting under the bonnet of your vehicle observe the following:

- If steam is seen coming from under the bonnet, do not open the bonnet until the steam has subsided. The engine compartment may be very hot, causing serious injury such as burns.
- Check that  on the multi-information display and the READY indicator are off.
- For vehicles with a hybrid system, there are times when the petrol engine automatically starts to run or the cooling fans suddenly start to operate. Do not touch or approach the rotating parts of the belt or fans.
Doing so may lead to fingers, clothes or tools getting caught, resulting in injury.
- Do not loosen the coolant reservoir cap while the hybrid system and radiator are hot.
Serious injury, such as burns, may result from hot coolant and steam released under pressure.

⚠ NOTICE

When adding engine / power control unit coolant observe the following:

- Wait until the hybrid system has cooled down before adding engine / power control unit coolant.
- When adding coolant, do so slowly. Adding cool coolant to a hot hybrid system too quickly can cause damage to the hybrid system.

To prevent damage to the cooling system Observe the following precautions:

- Avoid contaminating the coolant with foreign matter (such as sand or dust etc.)
- Do not use commercially available coolant additives.

After the engine coolant temperature has cooled to normal, again check the coolant level in the reservoir. If necessary, bring it up to half full again. Serious coolant loss indicates a leak in the system. You should have it checked as soon as possible at your Toyota dealer.

Steps to take in an emergency

IF YOUR VEHICLE BECOMES STUCK

Carry out the following procedures if the tyres spin or the vehicle becomes stuck in mud, dirt or snow.

1. Stop the hybrid system. Set the parking brake and move the shift lever to P position.
2. Remove the mud, snow or sand from around the stuck tyre(s).
3. Place wood, stones or some other material under the tyres to help provide traction.
4. Restart the hybrid system.
5. Move the shift lever to the D or R position and carefully apply the accelerator to free the vehicle.

CAUTION

When attempting to free a stuck vehicle

If you need to push the vehicle back and forth to free it, make sure the surrounding area is clear to avoid striking other vehicles, objects or people. The vehicle may also lunge forward or lunge back suddenly as it becomes free. Use extreme caution.

When moving the shift lever

Be careful not to move the shift lever while the accelerator pedal is depressed. This may lead to unexpected rapid acceleration of the vehicle that may cause an accident resulting in death or serious injury

NOTICE

To avoid damaging the transmission and other components

- Avoid spinning the wheels and depressing the accelerator pedal more than necessary.
- If the vehicle remains stuck even after these procedures are performed, the vehicle may require towing to be freed.

IF YOUR VEHICLE HAS TO BE STOPPED IN AN EMERGENCY

Only in an emergency, such as if it becomes impossible to stop the vehicle in the normal way, stop the vehicle using the following procedure.

1. Steadily depress the brake pedal with both feet and firmly depress it. Do not pump the brake pedal repeatedly as this will increase the effort required to slow the vehicle.
2. Move the shift lever to N position.

If the shift lever can be moved to N position–

- (a) After slowing down, stop the vehicle in a safe place by the road.
- (b) Stop the hybrid system.

If the shift lever cannot be moved to N position–

- (a) Keep depressing the brake pedal with both feet to reduce vehicle speed as much as possible.

Steps to take in an emergency

- (b) Stop the hybrid system by pressing and holding the POWER switch for 3 seconds or more, or press it briefly 3 times or more in succession.
- (c) Stop the vehicle in a safe place by the road.

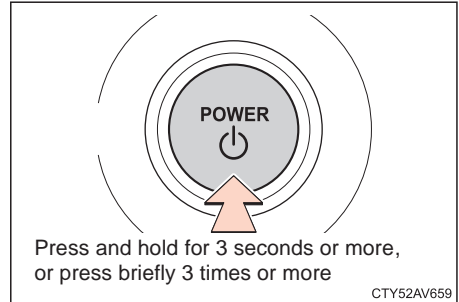

CAUTION

If the hybrid system has to be turned off while driving

- Power assistance for the brakes and steering will not work so steering and braking will be much harder than usual. Decelerate as much as possible before turning off the hybrid system.

Not for Reproduction

Not for Reproduction

VEHICLE SPECIFICATIONS

Specifications	332
DIMENSIONS	332
ENGINE NUMBER	332
VEHICLE IDENTIFICATION NUMBER (VIN).....	332
PETROL ENGINE	333
FUEL	334
ELECTRIC MOTOR	334
HYBRID BATTERY	334
LUBRICATION	335
COOLING SYSTEM	336
IGNITION	336
ELECTRICAL SYSTEM	336
TRANSMISSION	337
BRAKES	337
STEERING	337
TYRES AND WHEELS	338
Customisation	339
CUSTOMISABLE FEATURES	339
CUSTOMISING DOOR LOCK AND UNLOCK FUNCTIONS	344

Not for Reproduction



Specifications

Specifications

DIMENSIONS

Overall length	4815 mm (189.6 in.)
Overall width	1825 mm (71.9 in.)
Overall height (Unladen)	1470 mm (57.9 in.)
Wheelbase	2775 mm (109.3 in.)
Front tread	1575 mm (62.0 in.)
Rear tread	1565 mm (61.6 in.)

ENGINE NUMBER

The engine number is stamped on the engine block as shown.

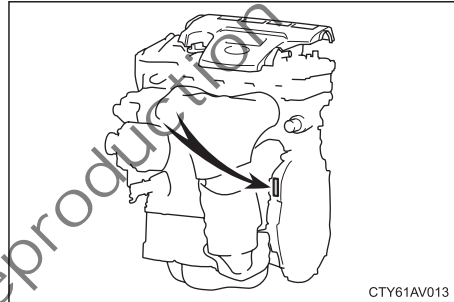

VEHICLE IDENTIFICATION NUMBER (VIN)

The vehicle identification number (VIN) is the legal identifier for your vehicle. This number is stamped under the right front seat.

This is the primary identification number for your Toyota. It is used in registering the ownership of your vehicle.

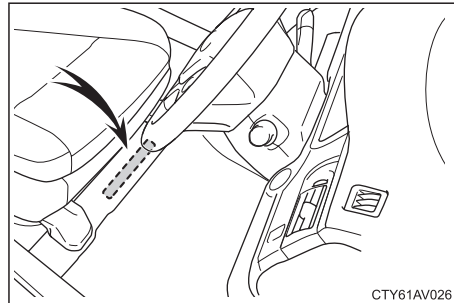

The vehicle identification number (VIN) is also on the manufacturer's label.

The manufacturer's label adhered on the left front and rear door pillars contains VIN and other model data such as date of manufacture.

Date of manufacture

The date of manufacture, indicated on the vehicle as the "Built Date", is the calendar month and year in which the body shell and powertrain sub-assemblies are joined and the vehicle is driven or moved from the production line.

Use the VIN, built date and other model data to identify your Toyota for purposes such as registration, parts ordering, insurance, and communication with Toyota.

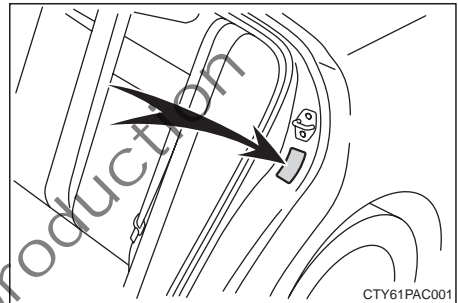
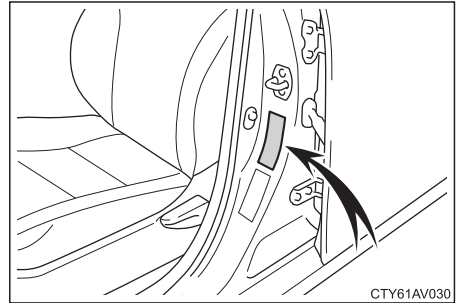

PETROL ENGINE

Model	2AR-FXE
Type	4 cylinder in line, 4 cycle, petrol
Bore and stroke	90.0 x 98.0 mm (3.54 x 3.86 in.)
Displacement	2494 cm ³ (152.2 cu in.)
Valve clearance (engine cold)	Automatic adjustment

Specifications

FUEL

Selecting the correct fuel is essential for satisfactory engine performance.

Engine damage caused by use of incorrect fuels is not covered under Toyota's new vehicle warranty.

Fuel type	Unleaded petrol only (Unleaded petrol containing up to 10% ethanol may be safely used)
Research Octane Number (RON)	91 or higher
Fuel tank capacity	65 L (18.5 gal., 15.4 Imp. gal.)

To help prevent petrol station mix-ups, your vehicle has a smaller fuel tank opening. The special nozzle on pumps with unleaded fuel will fit it, but the larger standard nozzle on pumps with leaded petrol will not.

NOTICE

Do not use leaded petrol. Use of leaded petrol will cause the three-way catalytic converter to lose its effectiveness and the emission control system to function incorrectly. Also, this can increase maintenance costs.

If your engine knocks

If you detect heavy knocking even when using the recommended fuel, or if you hear steady knocking while holding a steady speed on level roads, consult your Toyota dealer.

However, occasionally, you may notice light knocking for a short time while accelerating or driving up hills. This is normal and there is no need for concern.

ELECTRIC MOTOR

Type	Permanent magnet synchronous motor
Maximum output	105 kW
Maximum torque	270 N•m (27.5 kgf•m, 199 ft•lbf)

HYBRID BATTERY

Type	Nickel-metal hydride battery
Voltage	7.2 V/module
Capacity	6.3 Ah (3HR)
Quantity	34 modules
Overall voltage	244.8 V

LUBRICATION

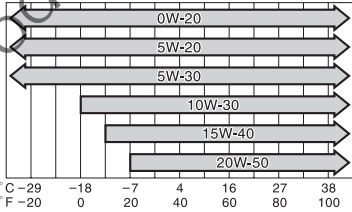
<p>Oil capacity (drain and refill*)</p> <ul style="list-style-type: none"> ▶ With filter ▶ Without filter 	<p>4.4 L (4.6 qt., 3.9 Imp. qt.)</p> <p>4.0 L (4.2 qt., 3.5 Imp. qt.)</p>
<p>Oil grade</p>	<p>0W-20, 5W-20, 5W-30 and 10W-30:</p> <p>API grade SL “Energy-Conserving”, SM “Energy-Conserving”, SN “Resource-Conserving” or ILSAC multigrade engine oil</p> <p>15W-40 and 20W-50:</p> <p>API grade SL, SM or SN multigrade engine oil</p>
<p>Recommended oil viscosity</p>	<p>“Toyota Genuine Motor Oil” is used in your Toyota vehicle. Use Toyota approved “Toyota Genuine Motor Oil” or equivalent to satisfy the following grade and viscosity.</p> <div style="text-align: center;">  <p>Temperature range anticipated before next oil change.</p> <p>ITNOIL063</p> </div>

*: The engine oil capacity is a reference quantity to be used when changing the engine oil. Warm up and turn off the hybrid system, wait more than 5 minutes, and check the oil level on the dipstick.

Please contact your Toyota dealer for further details.

Specifications

COOLING SYSTEM

Total capacity	
Petrol engine	7.8 L (8.3 qt., 7.0 Imp. qt.)
Power control unit	3.2 L (3.4 qt., 2.8 Imp. qt.)
Coolant type	<p>“Toyota Super Long Life Coolant” is used in your Toyota vehicle at factory fill.</p> <p>In order to avoid technical problems, only use “Toyota Super Long Life Coolant” or similar high quality ethylene glycol based non-silicate, non-amine, non-nitrite, and non-borate coolant with long-life hybrid organic acid technology.</p> <p>Coolant with long-life hybrid organic acid technology is a combination of low phosphates and organic acids.</p> <p>Do not use plain water alone.</p> <p>Contact your Toyota dealer for further details.</p>

IGNITION

Spark Plug	
DENSO	FK16HR-A8
Spark plug gap	0.8 mm (0.031 in.)

NOTICE

Use only iridium tipped spark plugs. Do not adjust the spark plug gap.

ELECTRICAL SYSTEM

12-volt auxiliary battery	
Open voltage* at 20°C (68°F):	12.6 — 12.8 V Fully charged 12.2 — 12.4 V Half charged 11.8 — 12.0 V Discharged (*: Voltage checked 20 minutes after the hybrid system and all the lights are turned off)
Charging rates	5 A max.

NOTE: If the 12-volt auxiliary battery requires replacement, ensure the new 12-volt auxiliary battery meets the same standard as the original.

TRANSMISSION

Fluid capacity*	3.7 L (3.9 qt., 3.3 Imp. qt.)
Fluid type	Toyota Genuine ATF WS

*: The fluid capacity is a reference quantity only.

Generally, it is necessary to change automatic transmission fluid only if your vehicle is driven under one of the Additional Service Requirements listed in your “Warranty and Service Book”.

When changing the automatic transmission fluid, use only “Toyota Genuine ATF WS” (ATF JWS3324 or NWS9638) to aid in assuring optimum transaxle performance.

 **NOTICE**

Using automatic transmission fluid other than “Toyota Genuine ATF WS” may cause deterioration in shift quality, locking up of your transmission accompanied by vibration, and ultimately damage the automatic transmission of your vehicle.

Please contact your Toyota dealer for further details.

BRAKES

Minimum pedal clearance –when depressed with the force of 500 N (51 kgf, 112 lbf) with the hybrid system running.	95 mm (3.74 in.)
Pedal free play	1–6 mm (0.04–0.24 in.)
Parking brake pedal travel –when depressed with the force of 300 N (31 kgf, 67 lbf)	7–10 clicks
Fluid type	SAE J1703 or FMVSS No.116 DOT 3

STEERING

Steering wheel free play	Less than 30 mm (1.2 in)
--------------------------	--------------------------

Specifications

TYRES AND WHEELS

16-inch wheels

Tyre size	215/60R16 95V
Tyre inflation pressure (cold tyre)	240 kPa (2.4 kgf/cm ² or bar, 35 psi)
Wheel size	Steel wheel: 16 x 6 1/2 JJ / Aluminium wheel: 16 x 6 1/2 J
Wheel nut torque	103 Nm (10.5 kgf m, 76 lb ft·)

17-inch wheels

Tyre size	215/55R17 94V tyres
Tyre inflation pressure (cold tyre)	240 kPa (2.3 kgf/cm ² or bar, 33 psi)
Wheel size	17 x 7 J
Wheel nut torque	103 Nm (10.5 kgf m, 76 lb ft·)

NOTE: For complete information on tyres (e.g. replacing tyres or replacing wheels), refer to "Tyres" on page 274 through to "Wheels" on page 278.

Not for Reproduction

Customisation

CUSTOMISABLE FEATURES

Introduction

Your vehicle includes a variety of electronic features that can be personalised. Programming some of these settings requires specialised equipment and must be performed by your Toyota dealer, while others you can do yourself. This is shown by a ✓ or ✕ in the applicable column for each system.

Touch-screen	These settings can be changed using the touch-screen audio system. For details refer to "Vehicle settings" on page 174.
Navigation	These settings can be changed using the navigation system. For further details, refer to the Navigation System Owner's Manual.
Dealer	These settings can be changed by your Toyota dealer using specialised equipment.
Key	This setting can be changed with the wireless remote control on the electronic key. For details, refer to "Customising door lock and unlock functions" on page 344.

NOTE: Some settings may affect another system, this is shown where two systems are described together. Contact your Toyota dealer for further assistance.

Wireless remote control and Smart entry and start system*

Function	Default Setting	Customised setting	Touch-screen*	Navigation*	Dealer*
Time before automatic door lock function is activated, if door is not opened after being unlocked	30 seconds	60 seconds 120 seconds	✕	✕	✓
Operation signal (hazard answer back)	ON	OFF	✕	✓	✓
Operation signal (door lock buzzer)	ON	OFF	✕	✕	✓
Open door warning buzzer	ON	OFF	✕	✕	✓
Operation buzzer volume (Lock feedback volume)	Level 5	OFF to Level 7	✓	✓	✓

* For further information on customising these systems refer to "Introduction" on page 339.

Customisation

Wireless remote control*

Function	Default Setting	Customised setting	Touch-screen*	Navigation*	Dealer*
Wireless remote control	ON	OFF	x	x	✓
Unlock operation (Remote 2-press unlock)	All doors unlocked in one step	Driver's door unlocked in one step, all doors unlocked in two steps	✓	✓	✓
Boot lid opening	Press and hold the boot lid open switch (short)	OFF Press and hold (long) Press twice One short press	x	x	✓

Smart entry and start system*

Function	Default Setting	Customised setting	Touch-screen*	Navigation*	Dealer*	Key*
Unlock the doors by simply carrying a key	All doors	Driver's door	x	✓	✓	x
Number of permissible times of continuous smart lock	Twice	Unlimited	x	x	✓	x
Smart entry and start system (Entry and start system)	ON	OFF	✓	✓	✓	x
Door unlock function	Holding either front door handle unlocks all doors	Holding the driver's door handle unlocks the driver's door Holding the front passenger's door handle unlocks all doors	x	x	x	✓

* For further information on customising these systems refer to "Introduction" on page 339.

Door lock*

Function	Default Setting	Customised setting	Touch-screen*	Navigation*	Dealer*
Speed-detecting automatic door lock function (Speed sensitive auto locking)	ON	OFF	✓	✓	✓
Opening the driver's door unlocks all the doors	OFF	ON	✗	✓	✓
Moving the shift lever to P position unlocks all doors (Auto unlock by shift to P)	OFF	ON	✓	✓	✓
Moving the shift lever out of P position locks all doors (Auto lock by shift from P)	OFF	ON	✓	✓	✓
Unlocking using a key	All doors unlocked in one step	Driver's door unlocked in one step, all doors unlocked in two steps	✗	✓	✓

Automatic light control system*

Function	Default Setting	Customised setting	Touch-screen*	Navigation*	Dealer*
Light sensor sensitivity	Level 3	Level 1 to Level 5	✓	✓	✓
Time before headlights automatically come on	Standard	Longer	✗	✗	✓
Automatic high beam system	ON	OFF	✗	✗	✓

* For further information on customising these systems refer to "Introduction" on page 339.

Customisation

Interior illumination*

Function	Default Setting	Customised setting	Touch-screen*	Navigation*	Dealer*
Time before interior lights turn off	15 seconds	OFF 7.5 seconds 30 seconds	✗	✓	✓
Operation when the doors are unlocked	ON	OFF	✗	✗	✓
Operation after the POWER switch is pressed OFF	ON	OFF	✗	✗	✓
Operation when you approach the vehicle with the electronic key on your person	ON	OFF	✗	✗	✓

Automatic air conditioning system*

Function	Default Setting	Customised setting	Touch-screen*	Navigation*	Dealer*
Switching between outside air and recirculated air mode linked to AUTO switch operation	Auto	Manual	✗	✓	✓
A/C auto switch operation	Auto	Manual	✗	✓	✓

* For further information on customising these systems refer to "Introduction" on page 339.

Power windows and moon roof*

Function	Default Setting	Customised setting	Touch-screen*	Navigation*	Dealer*
Key linked opening	OFF	ON	x	x	✓
Key linked closing	OFF	ON	x	x	✓
Wireless remote control linked opening	OFF	ON	x	x	✓
Wireless remote control linked opening buzzer	ON	OFF	x	x	✓

Moon roof*





Function	Default Setting	Customised setting	Touch-screen*	Navigation*	Dealer*
Linked operation of components when door key is used	Slide only	Tilt only	x	x	✓
Linked operation of components when wireless remote control is used	Slide only	Tilt only	x	x	✓



* For further information on customising these systems refer to "Introduction" on page 339.

Customisation

CUSTOMISING DOOR LOCK AND UNLOCK FUNCTIONS

It is possible to set which doors the smart entry function unlocks when using the wireless remote control on the electronic key.

1. Press the POWER switch off.
2. When the indicator on the key is off, press and hold either  or  or  for about 5 seconds while also pressing and holding .
3. A confirmation beep will sound.
 - The setting will change (from default to customised to default, etc.) each time the above operation is performed.

Setting	Multi-information display	Unlocking doors	Beep
Customised		<ul style="list-style-type: none"> • Holding the driver's door handle unlocks only the driver's door • Holding the front passenger's door handle unlocks all doors. 	Exterior: Three double beeps Interior: Beeps once
Default		Holding either front door handle unlocks all doors	Exterior: Two double beeps Interior: Beeps once

- If changing the setting continuously, release the buttons after each change, wait for at least 5 seconds, and repeat step 2.
- To prevent unintended triggering of the alarm after the settings have been changed, unlock the doors using the wireless remote control and open and close a door once.
 - If a door is not opened within 30 seconds after  is pressed, the doors will be locked again and the alarm will automatically be set.
 - If the alarm is triggered, immediately stop the alarm by pressing a switch on the electronic key or pressing the POWER switch to ON mode.

ALPHABETICAL INDEX

Not for Reproduction



A

Abbreviations	xvii
ABS warning light	97
Adjustments:	
Front seats	33
Mirrors	47
Seatbelts	41
Steering wheel	46
Airbags	62
Air conditioning system:	161
Air conditioning filter	279
Air vents	168
Rear window defogger	169
Alarm	58
Aluminium wheel precautions	278
Anti-glare inside rear view mirror	47
Anti-lock braking system	140
Appearance care:	
Cleaning and protecting the exterior ..	254
Cleaning and protecting the interior ..	257
Armrest	40
Assist grips	251
Audio system, touch screen	170
Audio system	176
Bluetooth® settings	233
Hands-free system (for mobile phones)	211
Listening to an iPod®	189
Listening to a USB memory	194
Listening to Bluetooth® audio	201
Optimal use of the audio system	208
Playing an audio CD and MP3 / WMA discs	181
Quick reference	170
Setting the hands-free system	224
Setup menu	171
steering wheel audio switches	209
Using the AUX port	200
Using the bluetooth phone	215

Using the CD player	181
Using the radio	179
Vehicle information	174

Auto anti-glare inside rear view mirror ..	47
--	----

Automatic air conditioning system	161
---	-----

Automatic high beam	118
---------------------------	-----

Automatic high beam warning light	97
---	----

Automatic transmission – See Hybrid transmission	
---	--

Auxiliary boxes	242
-----------------------	-----

Auxiliary catch - bonnet	263
--------------------------------	-----

AUX port	200
----------------	-----

B

Battery:	
12-volt auxiliary battery	280
Gas precautions	280
Hybrid battery	xviii
Jump starting	323
Recharging precautions, 12-volt auxiliary battery	282
Remote control transmitter	303
Winter driving tips	150

Blind spot monitor (BSM)	136
--------------------------------	-----

Bluetooth® audio	201
------------------------	-----

Bluetooth® phone	215
------------------------	-----

Bonnet release	263
----------------------	-----

Boot lid	31
Opening the boot lid from outside the vehicle	20

Bottle holders	245
----------------------	-----

Brake assist system	140
---------------------------	-----

Brake pad wear indicators	146
---------------------------------	-----

Brakes:

Brake Assist	140
Checking the brake fluid level	272
Parking brake	90

- Brake system warning light 96
- Brightness control, instrument cluster .. 93
- Bulbs, replacement 291
- C**
- CD player 181
- Charging system warning light 96
- Checking and replacing fuses 283
- Checking the brake fluid level 272
- Checking the engine coolant level 270
- Checking the engine oil level 266
- Checking the power control unit coolant level 271
- Checking the radiator and condenser .. 272
- Checking the tyre inflation pressure 274
- Child restraint 73
 - Anchor fittings 75
 - Child restraint system 74
 - Precautions 73
- Cleaning and protecting the exterior 254
- Cleaning and protecting the interior 257
- Clock 247
- Coat hooks 252
- Cold weather driving 150
- Condenser:
 - Checking the condenser 272
- Console box, rear 243
- Cooling system:
 - Engine coolant level 270
 - If your vehicle overheats 325
 - Power control unit coolant level 271
 - Radiators and condenser 272
 - Winter driving tips 150
- Cruise control 126
- Cup holders:
 - Front 244
 - Rear 245
- Curtain shield airbags 65
- Customisation:
 - Customisable features 339
 - Door lock and unlock functions 344
- D**
- Defogger, rear window 169
- Dimensions 332
- Dimmer switch - Headlight 116
- Does your vehicle need repairing? 260
- Do-it-yourself maintenance:
 - Service precautions 261
- Doors 28
- Driving:
 - Driving and parking using smart entry and start system 85
 - Hybrid system overview 2
 - Hybrid transmission 86
- Driving assist systems 140
 - Hill-start assist control 142
 - TRC/VSC/ABS 140
- Driving information:
 - Driving in various conditions 145
 - Pre-trip safety check 144
 - Running-in period 144
 - Snow tyres and chains 151
 - Trailer towing 152
 - Winter driving 150
- E**
- Eco drive mode 88
- Electrical:
 - 12-volt auxiliary battery 280
 - Checking and replacing fuses 283
 - Fuse layout and amperage ratings 286
 - Hybrid high voltage components 7

Electric motor	334
Electric Power Steering (EPS)	140
Electric power steering warning light and buzzer	97
Emergency flashers	306
Emergency, in case of:	
A flat tyre	312
A warning light illuminates or a buzzer sounds	311
Emergency flasher switch	306
Jump starting	323
Replacing fuses	283
The 12-volt auxiliary battery is discharged	322
The electronic key does not operate properly	321
The hybrid system will not start	319
The shift lever cannot be moved from P position	320
What to do if	354
You lose your keys	320
Your vehicle becomes stuck	323
Your vehicle has to be stopped in an emergency	328
Your vehicle needs to be towed	306
Your vehicle overheats	325
You think something is wrong	310
Emergency shut off system	6
Engine:	
Bonnet release	263
Checking the engine coolant level	270
Checking the engine oil level	266
Checking the power control unit coolant level	271
Engine compartment overview	266
Engine number	332
Engine oil consumption	269
Engine immobiliser system	57
EV drive mode	3, 83

F

Facts about engine oil consumption	269
Flat tyre	312
After changing wheels	319
Installing the spare tyre	317
Jacking precautions	312
Location of the spare tyre, jack and tools	313
Removing a flat tyre	316
Floor jack	264
Floor mat	76, 250
Fluid levels:	
Brake fluid	272
Engine coolant	270
engine oil	266
Power control unit coolant	271
Washer fluid	273
Fog lights	122
Fold-down rear seat	40
Front airbags	62
Front cup holders	244
Front seats	33
Fuel:	
Capacity	334
Emergency shut off system	6
Fuel filler door opener	55
Fuel gauge	91
Fuel tank cap	55
Fuel type	334
Information	334
Fuses	283
Checking and replacing fuses	283
Fuse box locations	283
Fuse layout and amperage ratings	286

G

Gauges and meters	91
Glove box	242
Grocery bag hooks	246

H

Hand brake – See Parking brake	
Hands-free system (for mobile phones)	211
Hazard switch – See Emergency flashers	
Headlights	116
Automatic high beam	118
Bulbs	294
Head restraints	36
High engine coolant temperature warning light	96
High speed operation: During running-in	144
Hill-start assist control system	142
Horn	90
Hybrid battery	xviii, 334
Hybrid high voltage components	7
Hybrid system:	
Checking the power control unit coolant level	271
Emergency shut off system	6
Energy monitor	8
EV indicator	3
High voltage precautions	7
Hybrid battery air vent	6
Hybrid system indicator	94
Past record screen	13
Precautions	5
Regenerative braking	3
Starting the hybrid system	79
Trip information screen	12

Hybrid system indicator	94
Hybrid transmission	86
Shift lock override button	320

I**Identification:**

Engine number	332
Vehicle identification number (VIN)	332

Ignition switch – See Power switch

Illuminated entry system	240
--------------------------------	-----

Immobiliser system	57
--------------------------	----

Indicators and warning lights	95
-------------------------------------	----

Inside rear view mirrors	47
--------------------------------	----

Instrument cluster	91
--------------------------	----

Gauges and meters	91
Hybrid system indicator	94
Indicators and warning lights	95
Instrument cluster light control button	93
Multi-information display	100
Odometer / trip meter display	92
Outside temperature display	93

Instrument panel:

Clock	247
Power outlet	247
Rear passenger seatbelt warning light	99
Security indicator	99

Interior lights	238
-----------------------	-----

iPod®	189
-------------	-----

J**Jack:**

Positioning a floor jack	264
Positioning the vehicle jack	316
Vehicle jack	313

Jump starting	323
---------------------	-----

K

Keyless entry	17
Keys	15
Knee airbags	62

L

Light bulbs	291
Back-up light	301
Fog light	297
Front turn signal light	296
Headlight high beam	294
Headlight, low beam	294
Licence plate light	302
Parking light	295
Rear turn signal light	299
Stop/tail light	299
Lights, interior	238
Illuminated entry system	240
Personal lights	239
Lock:	
Boot lid	34
Doors	28
Smart entry and start system	19
Steering lock	81
Low engine oil pressure warning light ...	96
Low fuel warning light	98
Luggage stowage precautions	157

M

Maintenance:	
Does your vehicle need repairing?	260
Do-it-yourself maintenance	261
Precautions	261
Requirements	259
Where to go for service?	259
Malfunction indicator warning light	97
Master warning light	98
Memory seats	38

Microphone	211
------------------	-----

Mirrors:

Anti-glare inside rear view mirror	47
Auto anti-glare inside rear view mirror .	47
Folding rear view mirrors	49
Outside rear view mirrors	48
Vanity mirrors	249

Moon roof	52
-----------------	----

MP3 / WMA discs	181
-----------------------	-----

Multi-information display	100
---------------------------------	-----

N

New vehicle, running in	144
-------------------------------	-----

O

Odometer/ trip meter display	92
------------------------------------	----

Oil, engine	266
-------------------	-----

Consumption	269
Engine oil level	266
Information	335

Outside temperature display	93
-----------------------------------	----

Overheating:

High engine coolant temperature warning light	96
If your vehicle overheats	325

Overview:

Engine compartment	266
Hybrid system	2
Interior lights	238
Storage features	241
Touch screen audio	170

P

Panic alarm – See Alarm

Parking assist-sensor	133
-----------------------------	-----

Parking brake	90
Reminder message	103

Passcode	215
----------------	-----

Past record screen	13
Positioning a floor jack	264
Power (ignition) switch	78
Power outlets	247
Power windows	50
Pretensioners, seatbelts	60
Pre-trip safety check	144
Privacy	xx
Protecting your Toyota from corrosion .	256

Q

Quick reference - touch screen audio system	170
--	-----

R

Radiators:

Checking the engine coolant level	270
Checking the power control unit coolant level	271
Checking the radiators	272

Radio	179
-------------	-----

Ready indicator	95
-----------------------	----

Rear console box	243
------------------------	-----

Rear electric sunshade	249
------------------------------	-----

Rear seats	40
------------------	----

Rear view mirrors:

Anti-glare inside rear view mirror	47
Auto anti-glare inside rear view mirror .	47
Folding rear view mirrors	49
Outside rear view mirrors	48

Rear view monitor system	128
--------------------------------	-----

Rear window defogger	169
----------------------------	-----

Regenerative braking	3
----------------------------	---

Remote control transmitter:

Battery replacement	303
Operation	17

Running-in period	144
-------------------------	-----

S

Safety check, pre-trip	144
------------------------------	-----

Seatbelts	41
-----------------	----

Child restraint anchor fittings	75
Fastening and releasing	44
Precautions	41
Pretensioners	60

Seats:

Front	33
Memory	38
Rear	40

Service and maintenance	259
-------------------------------	-----

Service Station Information	2
-----------------------------------	---

Shift lever:

Hybrid transmission	86
If the shift lever cannot be moved from P position	320

Side airbags	63
--------------------	----

Slip indicator warning light	97
------------------------------------	----

Smart entry and start system	19
------------------------------------	----

Alarms and warning lights	22
Battery-saving function	24
Customisation	340
Driving and parking	85
Emergency start function	320
Keys	15
Opening the boot lid	20
Power (ignition) switch	78
Starting the hybrid system	79
Unlocking and locking the doors	20

Snow tyres and chains	151
-----------------------------	-----

Spare tyre	313
------------------	-----

Spark plugs, iridium tipped	336	Headlights	116
Specifications	332	Moon roof	52
Speedometer	91	Parking assist-sensor	133
SRS airbags	62	Power (ignition)	78
Precautions	67	Power windows	50
SRS components	60	Rear electric sunshade	249
SRS front airbags	62	Rear window defogger	169
SRS side and curtain shield airbags	63	Steering wheel audio	209
Warning light	67	Telephone switches	211
Starting:		Windscreen wipers and washers	122
Jump starting	323		
Starting the hybrid system	79	T	
Steering:		Telephone switches (steering wheel) ...	211
Electric Power Steering	140	Telescopic steering wheel adjustment ...	46
Tilt and telescopic steering wheel	46	Theft deterrent system	57
Steering wheel audio switches	209	Tilt steering wheel adjustment	46
Stop/tail light bulbs	299	Tools	313
Storage:		Towing:	
Auxiliary boxes	242	Emergency towing	308
Bottle holders	245	If your vehicle needs to be towed	306
Cargo and luggage	157	Installing the front towing eyelet	309
Cup holders	244	Trailer towing	152
Glove box	242	Traction control system (TRC)	
Grocery bag hooks	246	140
Overview	241	Trailer towing	152
Rear console box	243	Transmission, hybrid	86
Sun roof – See Moon roof		Transmitter battery replacement	303
Sunshade, rear	249	Trip meters	92
Sun visors	248	Turn signals	89
Switches:		Tyres:	
Air conditioning system	161	Changing	316
Audio	170	Checking	276
Blind spot monitor	136	Checking inflation pressure	274
Door lock	28	Flat tyre	312
Eco drive	88	Inflation pressure	338
Emergency flashers	306	Replacing	276
EV drive mode	83	Rotating	277
Front fog lights	122	Spare	313
		Specifications	338

U

USB memory 194

V

Vanity mirrors 249

Vehicle identification number (VIN) 332

Vehicle stability control system (VSC) . 140

W

Warning lights and buzzers 95

Warning messages 100

Washer fluid 273

Washing the vehicle 254

What to do if 354

Wheels 278

Aluminium wheel precautions 278

Replacement 278

Windows, power 50

Windscreen wipers and washers 122

Winter driving tips 150

Wireless remote control

Battery replacement 303

Operation 17

WMA discs 181

What to do if...

A tyre punctures	→	page 312	<i>If you have a flat tyre</i>
The hybrid system does not start	→	page 319	<i>If your hybrid system will not start</i>
		page 57	<i>Engine immobiliser system</i>
		page 322	<i>If the 12-volt auxiliary battery is discharged</i>
		page 321	<i>If the electronic key does not operate correctly</i>
The shift lever cannot be moved	→	page 320	<i>If the shift lever cannot be moved from P position</i>
The engine coolant temperature display right-most segment flashes	→	page 325	<i>If your vehicle overheats</i>
Steam can be seen coming from under the bonnet			
The key is lost	→	page 320	<i>If you lose your keys</i>
The 12-volt auxiliary battery is flat	→	page 322	<i>If the 12-volt auxiliary battery is discharged</i>
The doors cannot be locked	→	page 28	<i>Doors</i>
The vehicle is stuck in mud or sand	→	page 328	<i>If the vehicle becomes stuck</i>
The warning light illuminates, a buzzer sounds or a warning message is displayed	→	page 311	<i>If a warning light illuminates, buzzer sounds or a warning message is displayed</i>



TOYOTA